

HS17 SERIES UNITS (813, 953 & 1353)

I - INTRODUCTION

The HS17 series units are designed for application with a remotely located blower-coil unit or a furnace add-on evaporator coil. Nominal capacities for the unit series are 6, 7-1/2 and 10 tons. The 7-1/2 and 10 ton units use the Lennox twin compressor for half capacity operation during periods of reduced loads; half and full capacity operation is controlled by a two stage room thermostat. Twin compressor units may also be operated as single stage units.

The HS17 series matches with the CB17 series blower-coil-filter units. The HS17-953 & 1353 units may be applied with the C2-95V and 135V series "A" coils when used with the G81-220 series furnaces. The C2 application with HS17 is single stage cooling operation; twin compressor operating at full capacity only.

A low ambient kit is available for operation of the unit from 35°F down to 0°F. Use kit LB-50352BA for the 813 and 953 models and use kit LB-50352BB for the 1353 models.

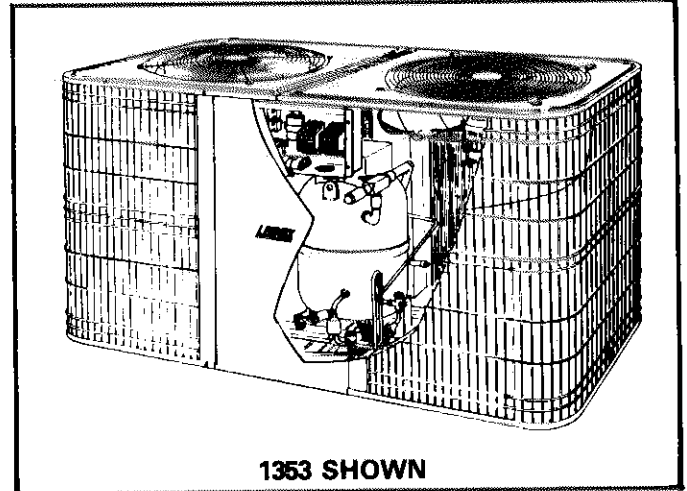

II - UNIT INFORMATION

A - Specifications

Model No.			HS17-813V	HS17-953V	HS17-1353V
Condenser	Net face area (sq. ft.)	Outer coil	21.36	21.36	33.44
		Inner coil	20.36	20.36	32.00
Coil	Tube diameter (in.) & No. of rows		3/8 - 2	3/8 - 2	3/8 - 2
	Fins per inch		20	20	20
Condenser Fan(s)	Diameter (in.) & No. of blades		24 - 4	24 - 4	(2) 24 - 4
	Motor hp		3/4	3/4	(2) 1/4
	Cfm (factory setting)		5800	5800	8000
	Rpm (factory setting)		1050	1050	850
	Watts (factory setting)		760	760	720 (total)
Refrigerant - 22 charge furnished			holding charge	holding charge	holding charge
Liquid line (o.d. in.) connection - sweat			5/8	5/8	5/8
Suction line (o.d. in.) connection - sweat			1-1/8	1-3/8	1-3/8

B - Electrical Data

Model No.		HS17-813V		
Line voltage data - 60 hz/3 phase		208/230v	480v	575v
Compressor	Rated load amps	20.0	10.0	8.0
	Locked rotor amps	135.0	68.0	54.0
Condenser Coil	Full load amps	3.7	1.9	1.6
	Locked rotor amps	7.3	3.7	3.4
Fan Motor (1 phase)				
Unit power factor		.89	.89	.91
Recommended maximum fuse or circuit breaker size (amps)		45	20	15
*Minimum circuit ampacity		28.7	14.4	11.6

*Refer to National Electrical Code manual to determine wire, fuse and disconnect size requirements.
NOTE - Extremes of operating range are plus and minus 10% of line voltage.

B - Electrical Data

Model No.		HS17-953V			HS17-1353V		
Line voltage data — 60 Hz/3 phase		208/230v	460v	575v	208/230v	460v	575v
Compressor	Rated load amps (total)	24.6	12.4	9.6	35.8	18.8	14.8
	Locked rotor amps (total)	148	74	60	252	126	100
Condenser Coil	Full load amps (total)	3.7	1.9	1.6	4.4	2.2	1.8
Fan Motor(s) 1 phase	Locked rotor amps (total)	7.3	3.7	3.4	9.0	4.0	3.4
Unit power factor		.90	.90	.91	.87	.87	.88
Recommended maximum fuse or circuit breaker size (amps)		40	20	15	60	30	25
*Minimum circuit ampacity		31.6	16.0	12.5	44.9	23.5	18.6

*Refer to National Electrical Code manual to determine wire, fuse and disconnect size requirements.
 NOTE — Extremes of operating range are plus and minus 10% of line voltage.

C - Dimensions

HS17-813V AND 953V

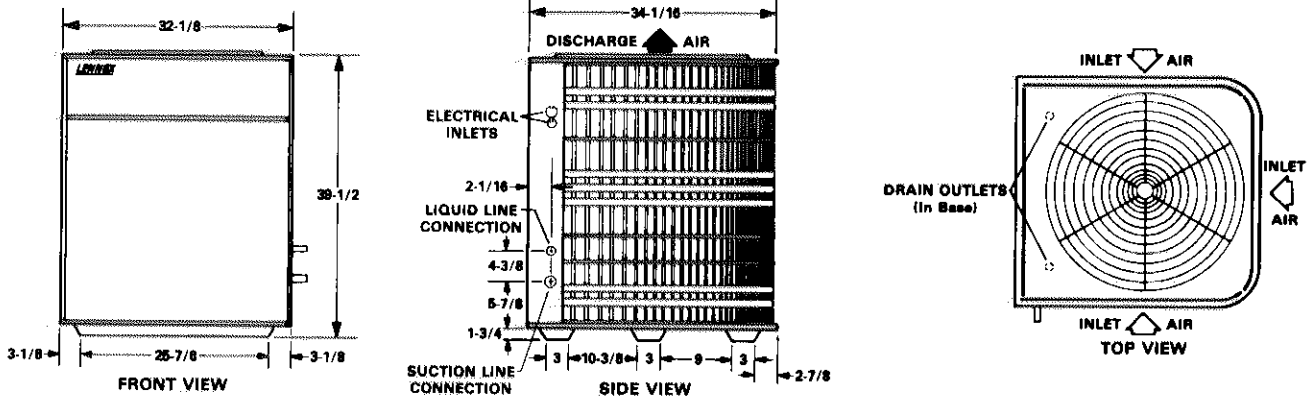

HS17-1353

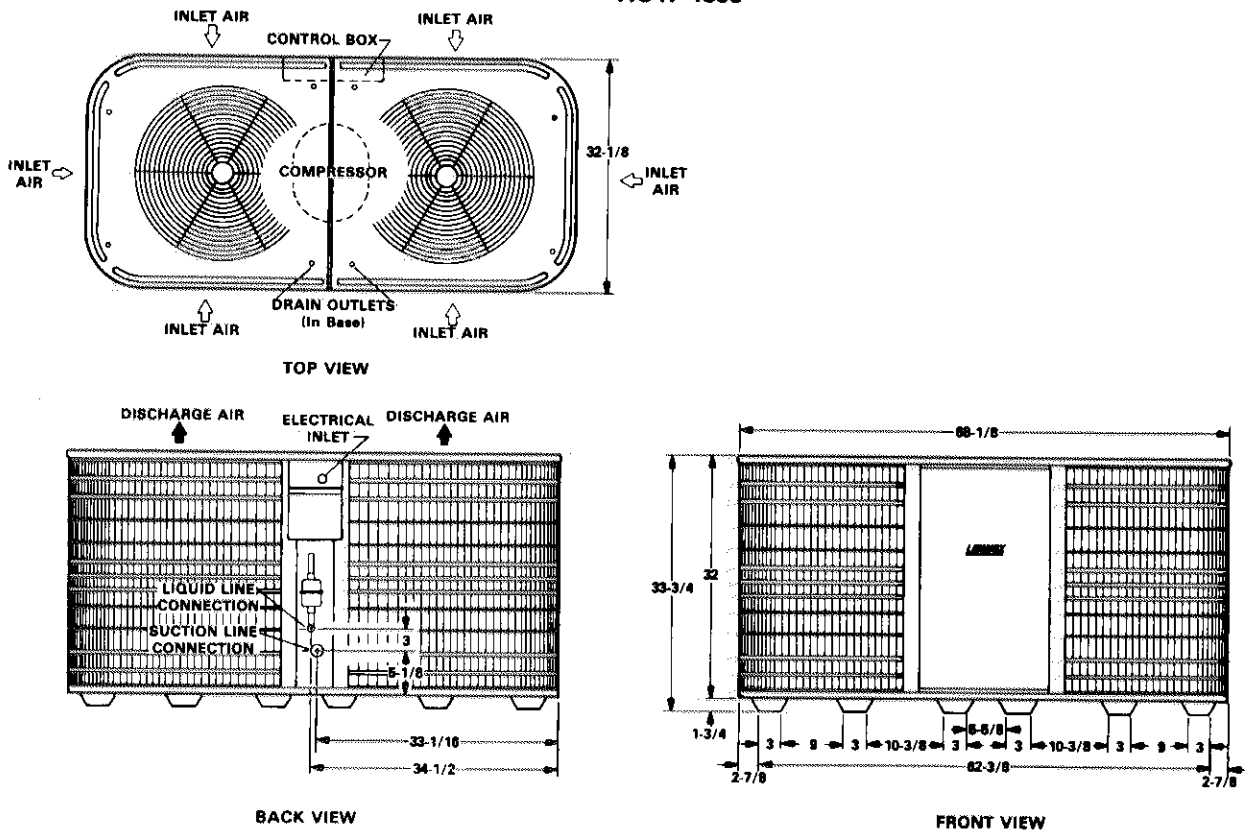

D - Pressure Curves

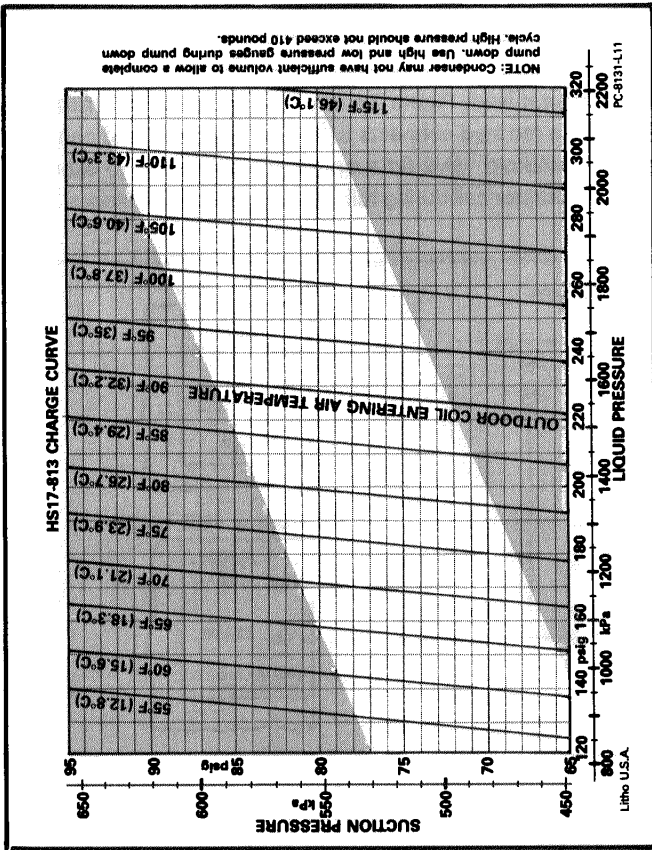

Each unit is furnished with a normal operating pressure curve. The curve uses suction pressure, liquid pressure and outdoor temperature comparison. To use the chart, first check suction pressure, then move over to the outdoor temperature and finally down to the liquid pressure. If the liquid pressure is within five pounds of this reading, the unit is properly charged, providing the three conditions meet in the unshaded area of the chart. If they meet in the shaded area, there is something wrong with the system and further checks are needed.

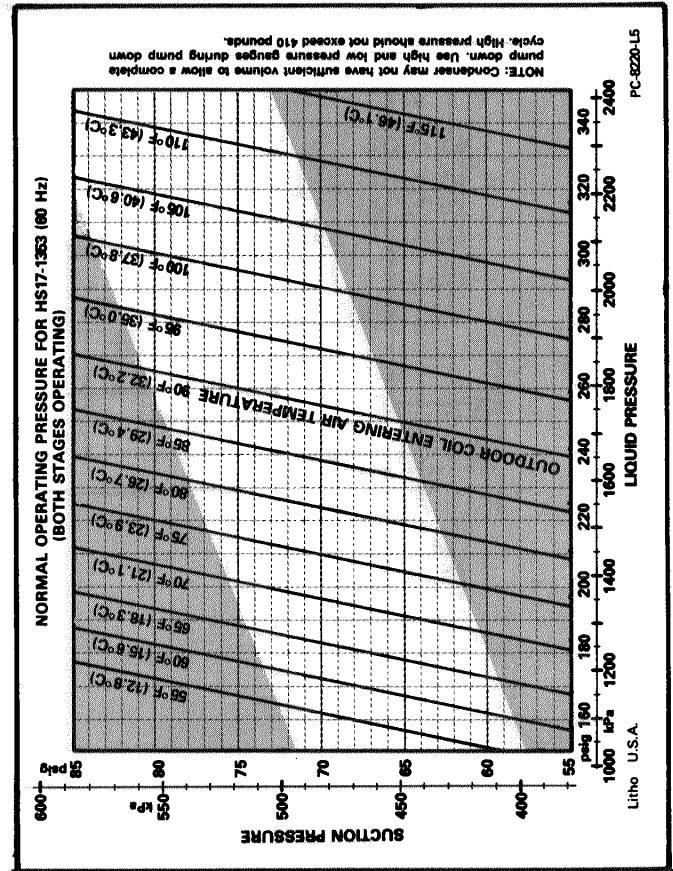
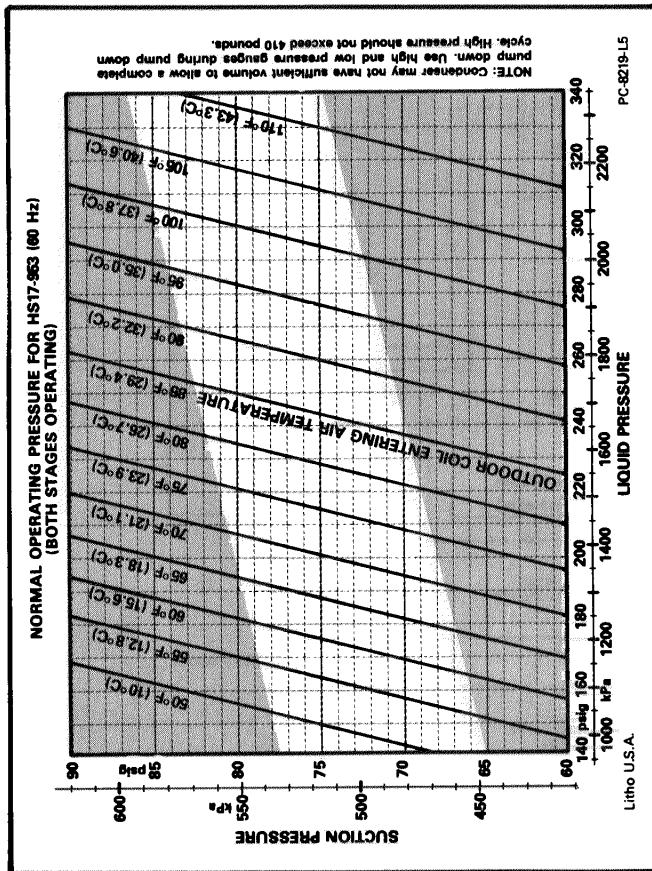

E - Field Wiring (Figures 1 & 2)

High Voltage three phase power wiring connects to pigtail leads in the unit make-up box. A ground lug is also provided.

Low Voltage field wiring thermostat connections are made to pigtail leads in the low voltage junction box. Note, as in Figure

1, when the HS17-953 or 1353 unit is connected for one stage operation only, the black and red leads connect together with the Y1 thermostat lead. Figure 2 shows two stage wiring of the 953 & 1353; the red lead connects to Y1 and the black lead connects to Y2. A solenoid valve (at evaporator coil) is used to allow full use of evaporator coil during full capacity operation - stages 1 & 2.

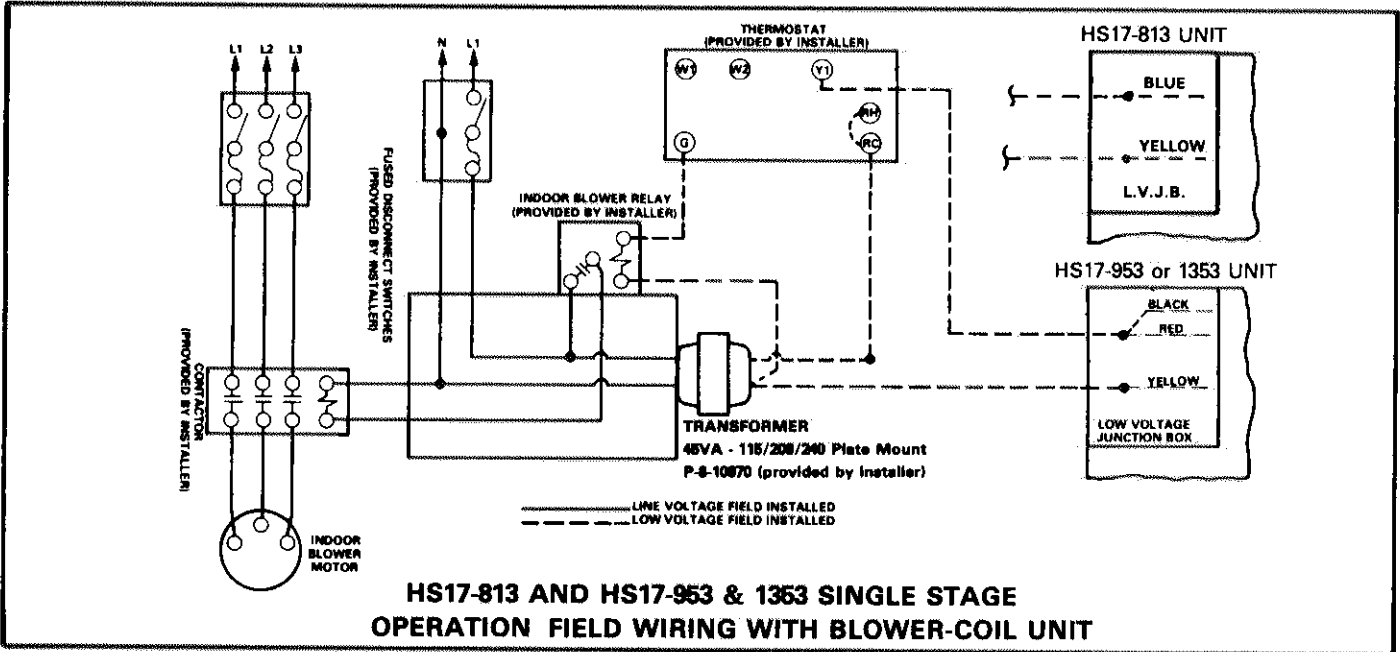

FIGURE 1

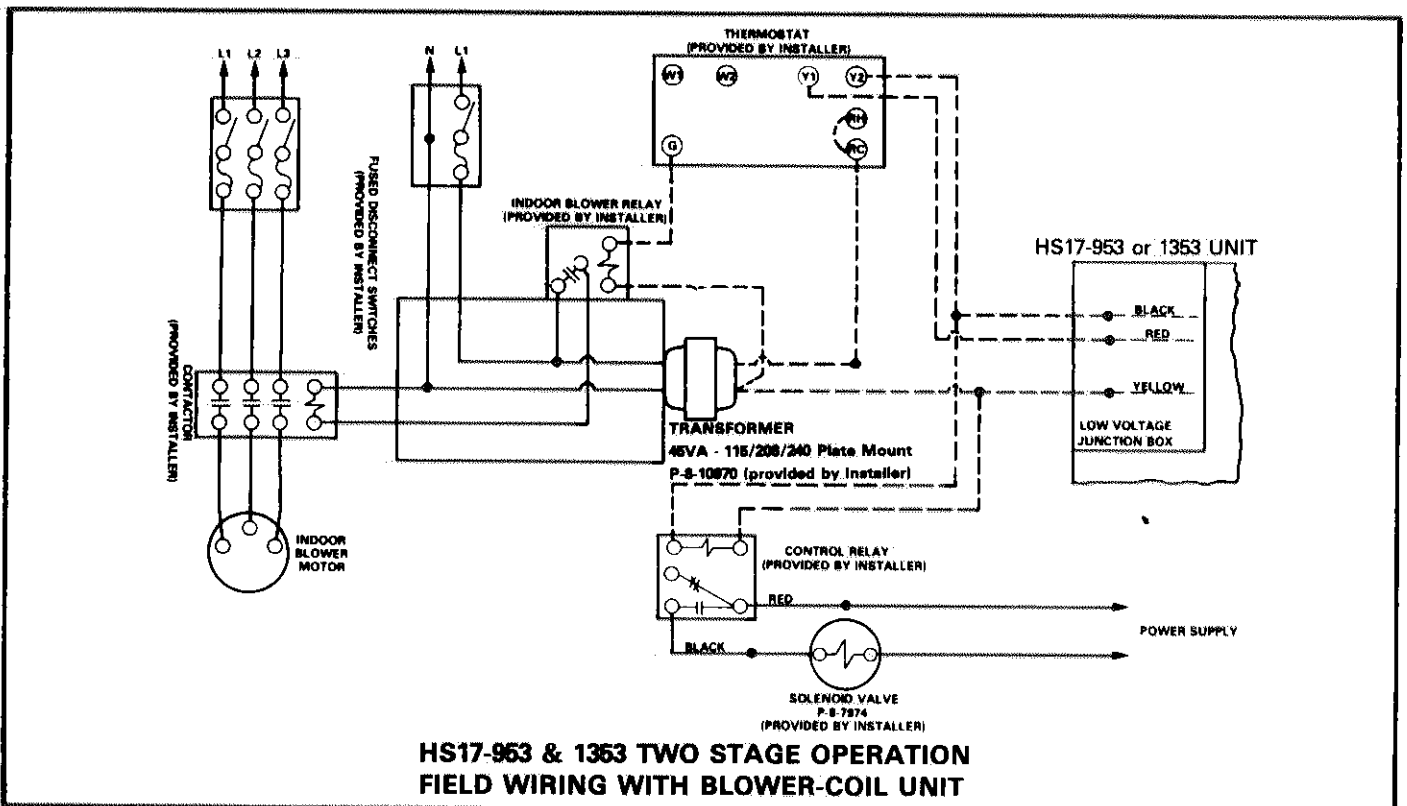

FIGURE 2

III - REFRIGERANT SYSTEM

Suction and liquid lines are stubbed outside the unit cabinet for sweat connections on all models. The suction and liquid line valves have gauge ports that can be shut off by backseating the valves. Open valve one turn off backseat to record pressure at gauge manifold.

The HS17-813 and 953 models use a single condenser coil and the 1353 uses dual coils. On the 1353 the refrigerant flow is split be-

tween both condenser coils and the entire evaporator coil during both full and half capacity operation where humidity control is not a factor. In most cases, humidity control is desired and a dual circuit evaporator coil is used with the 953 & 1353. The CB17 evaporator coil has two liquid line connections and a common suction line. A field provided solenoid valve is placed in the top (second stage) liquid line to shut off the circuit during first stage compressor operation, providing greater humidity control. See Figure 3.

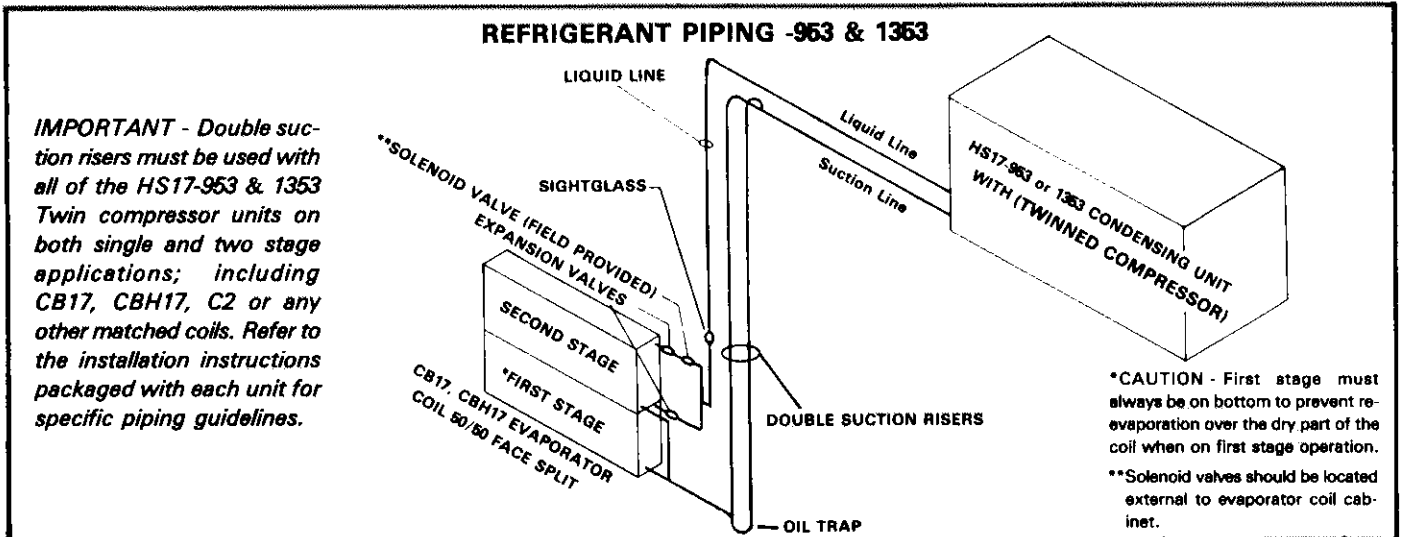

FIGURE 3

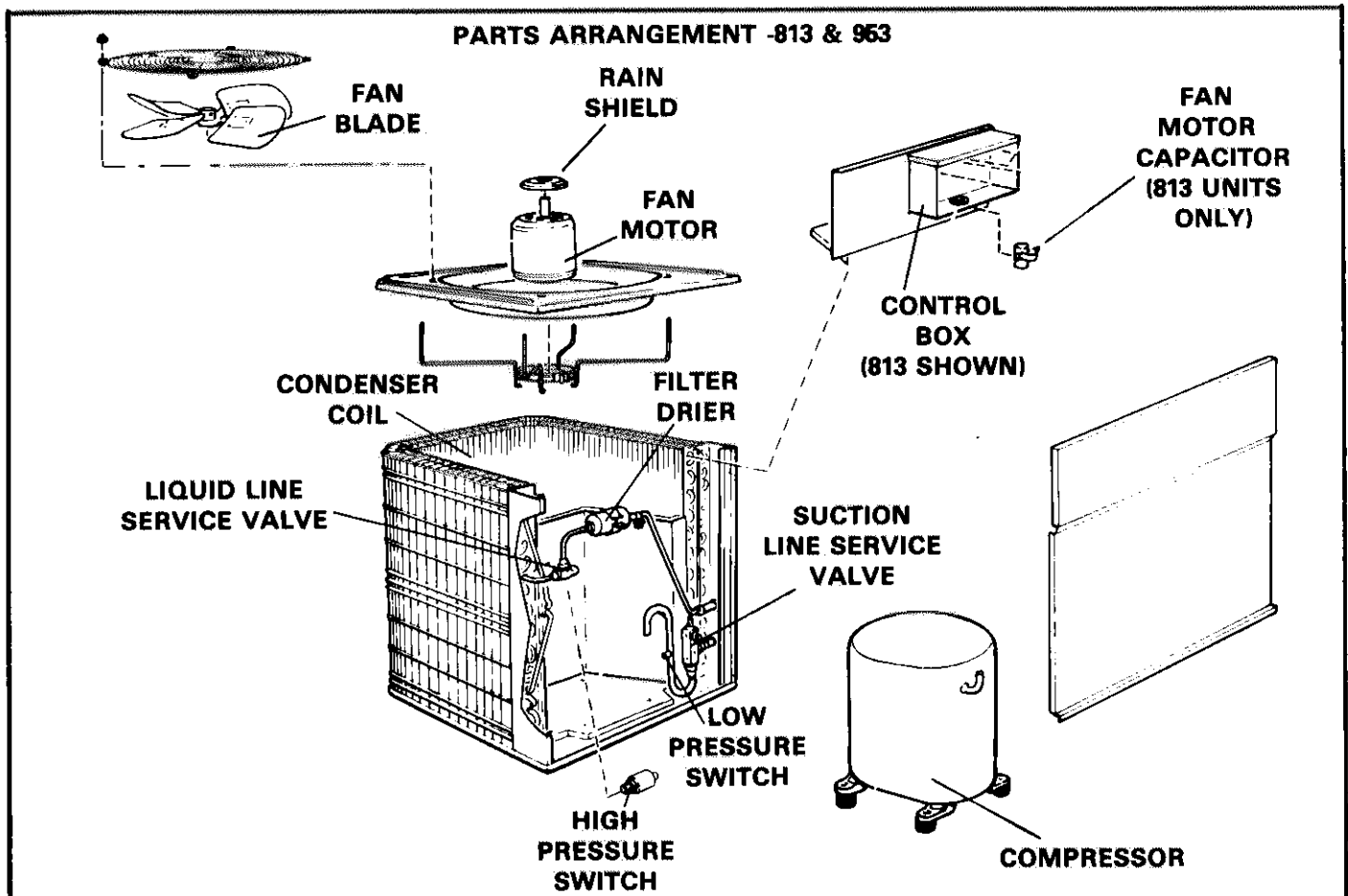

FIGURE 4

IV - COMPONENTS

Figure 4 shows a parts arrangement for the 813 & 953 series. Figure 5 shows parts arrangement for the 1353 series.

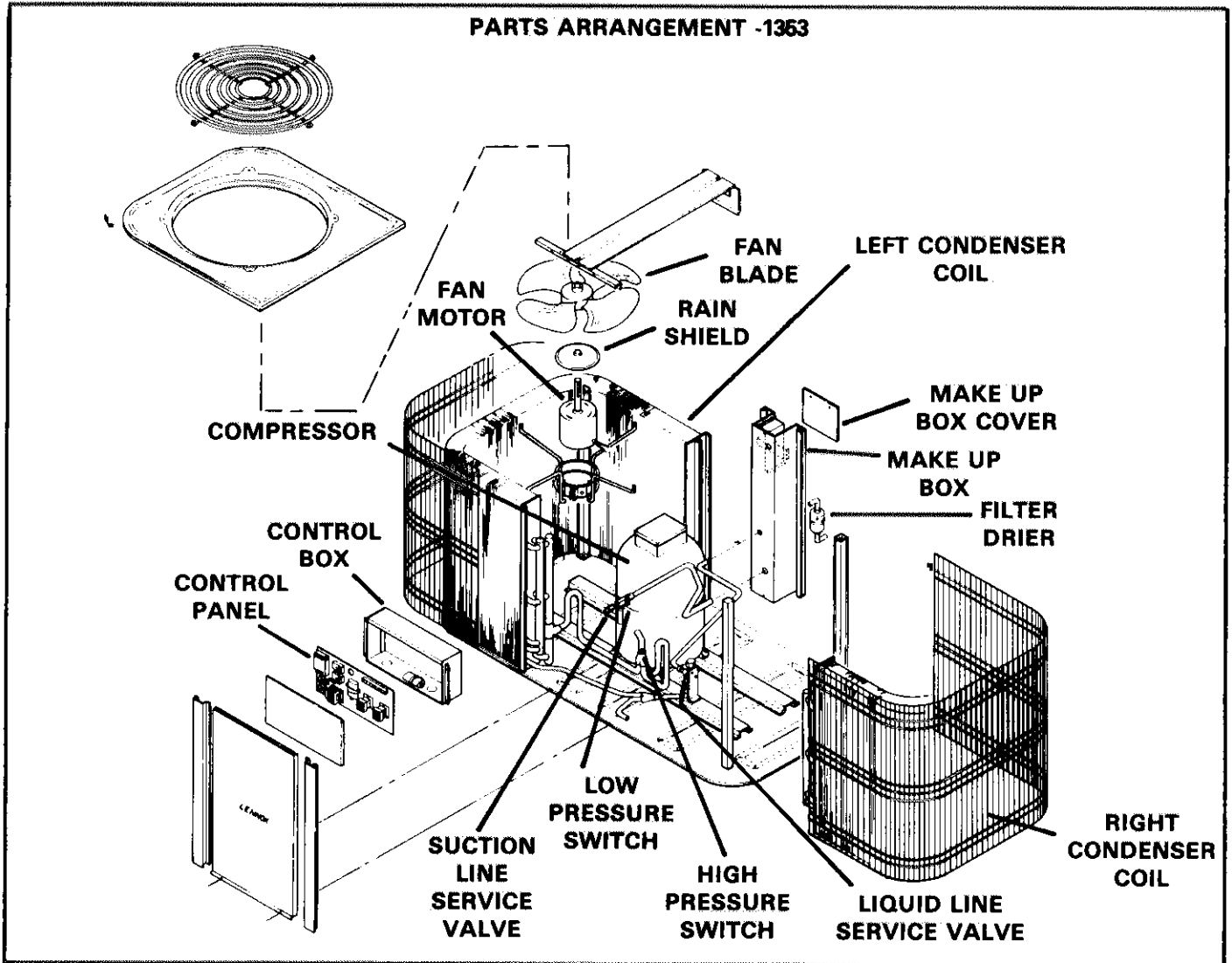

FIGURE 5

A - Control Box (Figure 6)

1 - Transformer (953 & 1353 only)

Primary voltage depending on unit voltage rating; primary is either 208/230V, 440V or 550V, secondary 24V, 50VA. Secondary is fused with Type C, 2.5 amp, 250V rated fuse.

2 - Timed Off Controls

Prevents compressor short cycling and allows time for suction and discharge pressures to equalize. The control locks out the control circuit for 5 minutes at the end of a cycle.

3 - Compressor Contactor (K1 & K2 on 953 & 1353)

Two used on 953 & 1353 units to operate each motor in the twin compressor. 3 P.N.O. with 24 VAC coil. One used on 813 unit.

4 - Control Relays (953/1353 only)

S.P.S.T., 24 VAC coil. K3 and K4 are used in the thermostat control circuit to operate stage 1 and 2.

5 - Fan Motor Capacitor

Located below control box on 813 units; in control box on 953 & 1353 units. Run capacitor for condenser fan motor(s). Two used on 1353 units.

6 - Protection Module (953 & 1353 only)

The module connects to sensors in the twin compressor motors through S1 and S2. It is supplied with 24 VAC at terminals P2 & P1. The compressor control circuit is connected to K1 & K2. If the sensors detect excessive motor temperatures, the module breaks power to the compressor control circuit. Refer to Page 9 for protection module checkout, Figure 9.

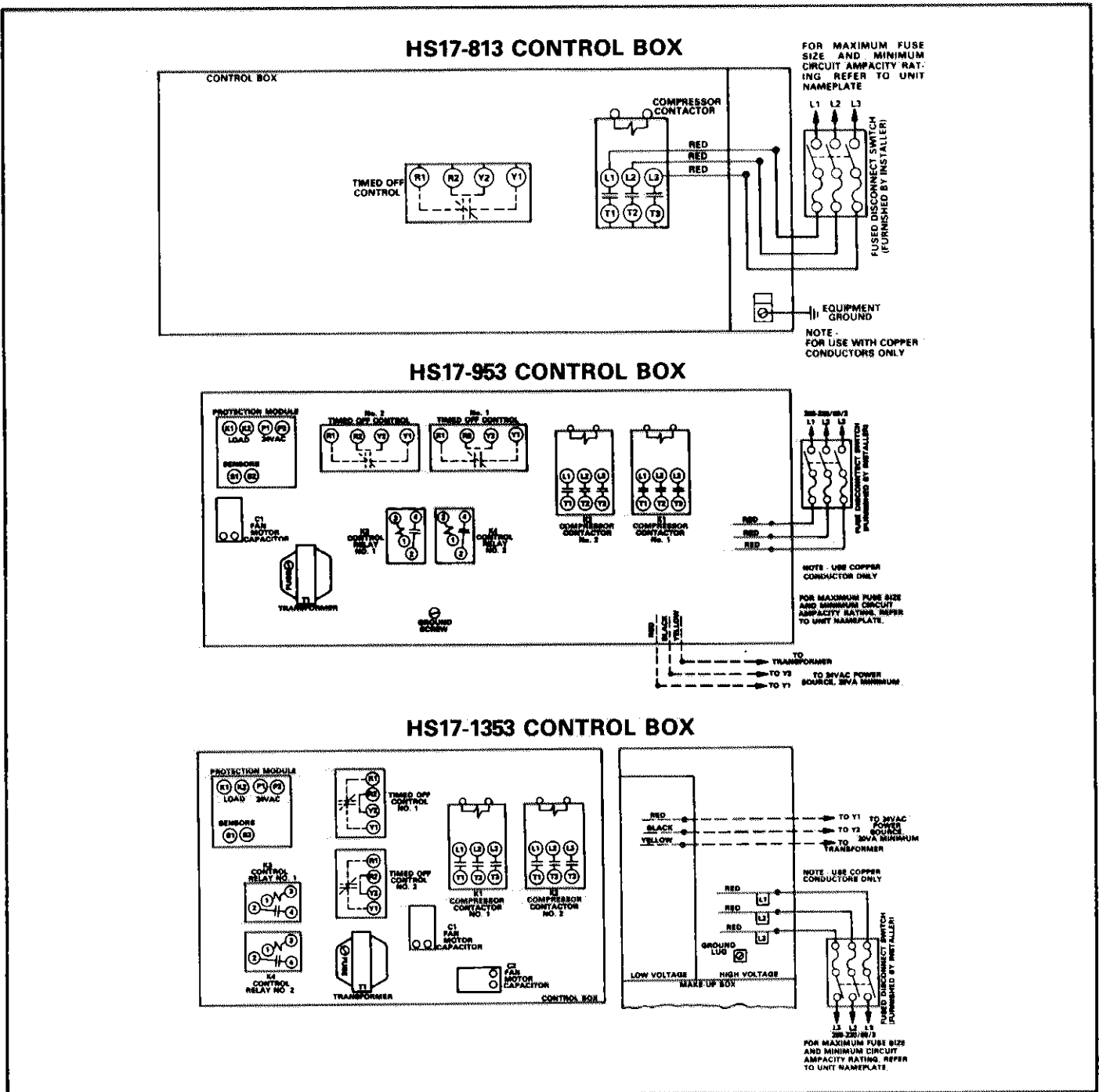

FIGURE 6

B - Compressor Compartment

Refer to parts arrangements, Figures 4 & 5.

1 - High Pressure Switch

Protects compressor from excessive pressure. Cutout pressure of 410 psig. Manual reset; will manual reset only after pressure

drops to 180 psig.

2 - Low Pressure Switch

Mounted in suction line. Cutout pressure of 25 psig ± 5 and automatic cut in pressure of 55 psig ± 5.

3 - Condenser Fan(s)

The 813 and 953 units use one fan, two are used on the 1353 with dual condenser coils. Air draws through the coil(s) and is discharged through top of unit. The fan motors are rated at line voltage of particular unit and operate with compressor. Refer to Figure 7 for fan motor assembly.

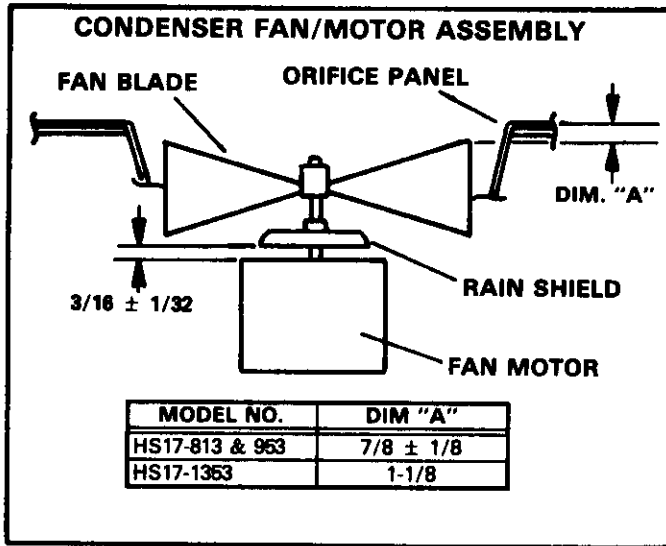

FIGURE 7

4 - Compressor

The 813 series use Bristol standard compressors, nominal 6 ton. The 953 and 1353 series use the Lennox Twin compressors; 953 nominal 7 ton and 1353 nominal 10 ton; full capacity. The Lennox "twin" compressor is two compressors in one housing with single suction and discharge lines. See Figure 8. One compressor is run for half capacity (Stage 1) and both compressors are run for full capacity (Stage 2).

The twin compressors are protected by the external high and low pressure switches and by the protection module (in control box) which senses winding temperatures from sensors buried in each motor winding.

All compressors in the HS17 series have PTC type internal self-regulating crankcase heaters that operate at the line voltage of the compressor. Crankcase heater for the 813 model is 40W. 953 and 1353 models are 60W.

5 - Compressor Oil Charge

Correct oil charges for HS17 compressor are as follows:

- HS17-813 models 65 ounces Suniso 3GS
- HS17-953 & 1353 models 132 ounces 25% ZEROL 150 Re: SP6108 75% Capela D or Suniso 4GS

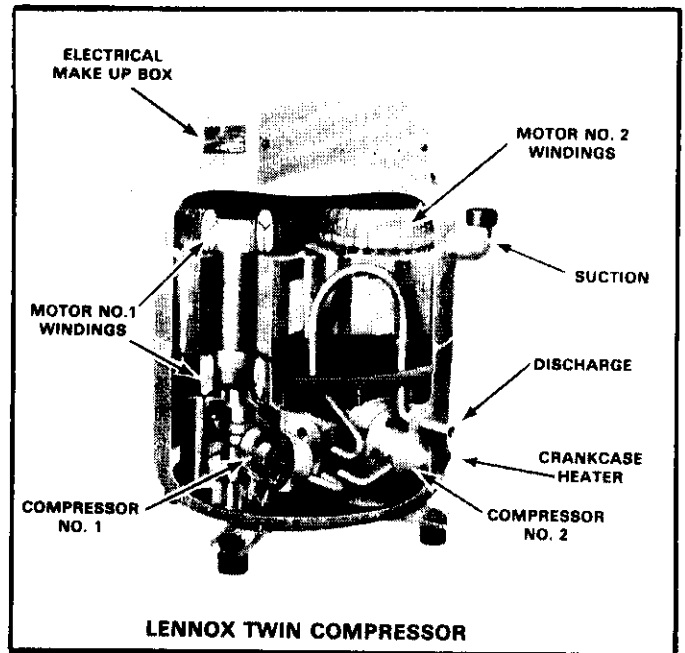

FIGURE 8

V - COMPRESSOR PROTECTION MODULE CHECKOUT

Thermal sensors with a positive temperature coefficient (PTC) change resistance in direct relationship to temperature change. The trip setting ranges from 26K to 34K and reset setting ranges from 10.5K to 13.5K.

If the compressor fails to operate, provide a cooling demand and check K1 and K2. Power indicates another component is open. Check power to module P1 and P2. Remove thermal sensor leads and check their resistance. Use resistors to check module operation. Refer to Figure 9.

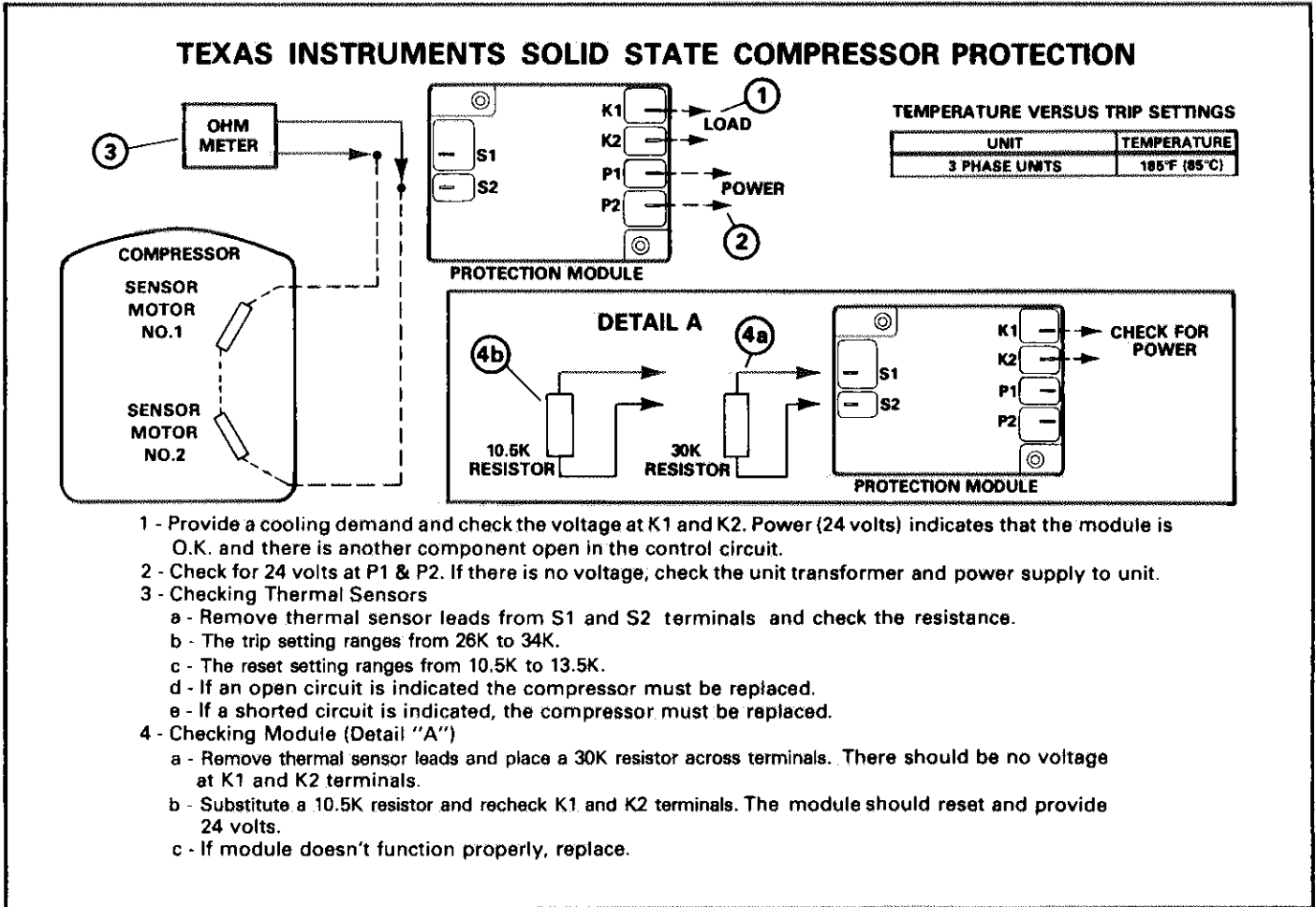

FIGURE 9

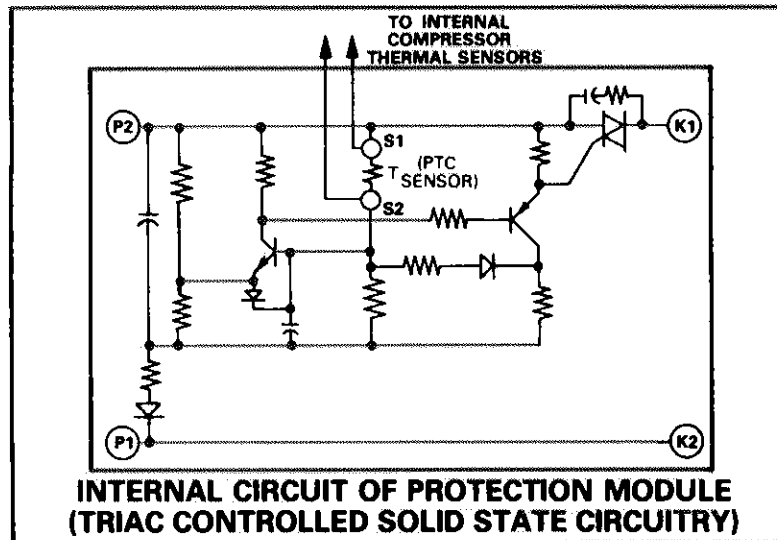

FIGURE 10

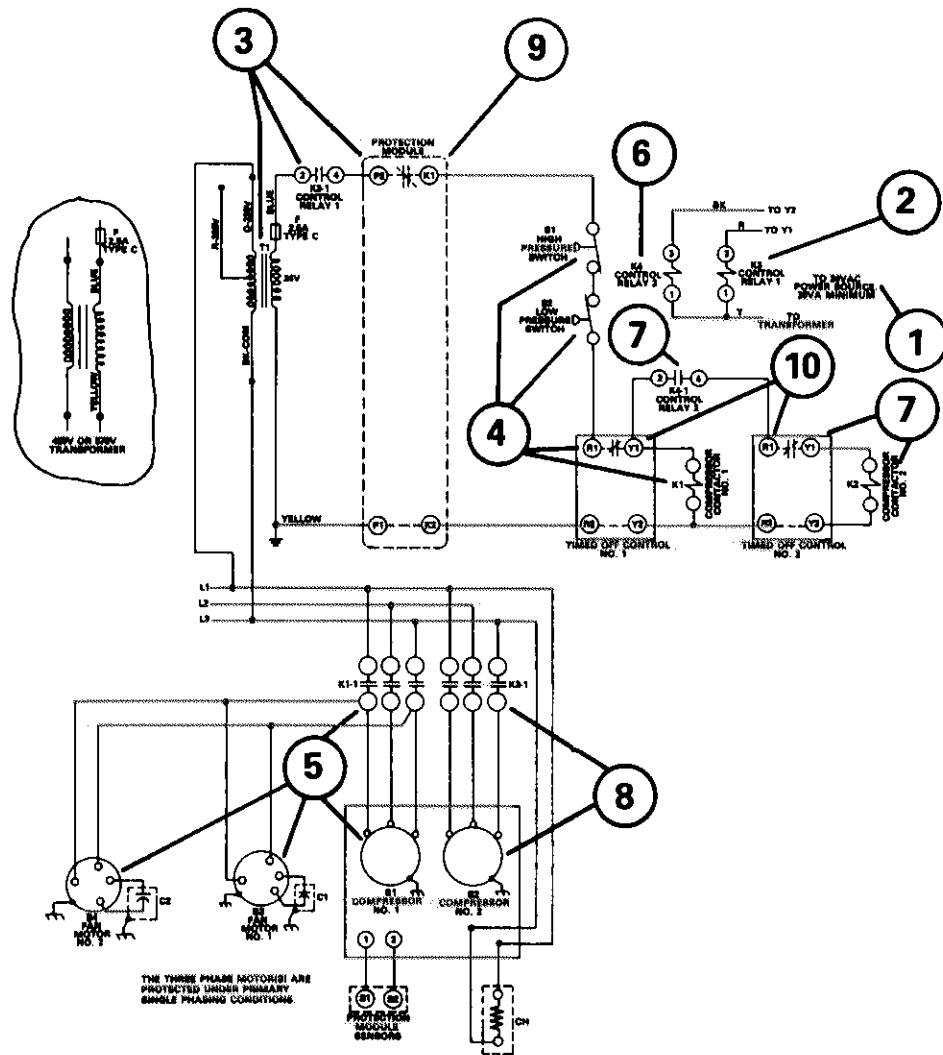

FIGURE 11

VI - SEQUENCE OF OPERATION

A - HS17-813 Series Units

Power for control of the 24 VAC compressor contactor is provided by the indoor unit or blower/coil unit transformer. When thermostat calls for cooling 24 VAC is applied through the HS17 timed off control N.C. contacts to energize the compressor contactor. The contactor contacts energizes the 3 phase compressor and the single phase condenser fan.

B - HS17-953 and 1353 Series Units (Figure 11)

The 953 and 1353 series operation is the same for each except the 953 uses only one condenser fan.

- 1 - Power for control relay operation by thermostat is provided by indoor unit or blower/coil unit transformer.
- 2 - A stage 1 cooling demand from the thermostat energizes K3 control relay No.1 through the Y1 leg.
- 3 - K3-1 N.O. contacts close to provide 24 VAC, from T1 transformer through K3-1 N.O. contacts and protection module P2-K1. N.C. circuit, to the compressor control circuit.

- 4 - Compressor contactor K1 is energized through S1 high pressure switch, S2 low pressure switch and timed off control No. 1, R1-Y1, N.C. circuit.
- 5 - Compressor contactor contacts K1-1 close to energize compressor motor No. 1 and condenser fan motor(s).
- 6 - On an increase in thermostat demand for stage 2 cooling, K4 control relay coil is energized through the Y2 leg.
- 7 - K4-1 N.O. contacts close providing 24 VAC from compressor contactor No. 1 circuit (now operating) through timed off control No. 2, R1-Y1, N.C. circuit to energize K2 compressor contactor No. 2 coil.
- 8 - Compressor contactor contacts K2-1 close to energize compressor motor No. 2
- 9 - The compressor and fans will be de-energized if the protection module P2-K1 N.C. circuit opens, following detection of excessive winding temperatures. P2-K1 breaks 24 VAC to control circuits.
- 10 - Following any off cycle the timed off control N.C. circuit R1-Y1 will open preventing compressor operation for 5 minutes.