

HS23 SERIES UNITS

The HS23 is a high-efficiency residential split-system condensing unit. Extra large condensing coil, coil circuiting and high condenser air volume result in a high SEER rating (minimum of 10.0). The series is designed for use with an expansion valve or RFCII system in the indoor unit.

All compressors are hermetically sealed for trouble-free operation and long service life. Compressor components are spring mounted within the sealed housing. The compressor is installed in the unit on resilient rubber mounts to assure quiet, vibration-free operation. A built-in protection device assures protection from excessive current and temperatures. Both high pressure and low pressure safety limits are furnished as standard.

HS23-510 through HS23-650 models are furnished with crankcase heaters as standard equipment to assure proper compressor lubrication at all times. The heater is temperature-actuated and operates only when required.

Several models are available in sizes ranging from 1 through 5 tons.

This manual is divided into sections which discuss the major components, refrigerant system, charging procedure, maintenance and operation sequence.

All specifications in this manual are subject to change.

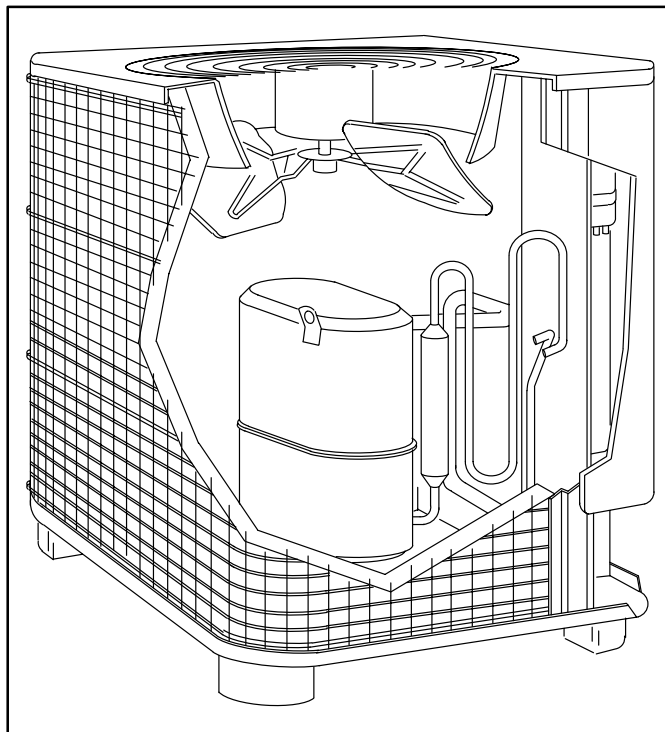

SPECIFICATIONS

Model No.		HS23-141	HS23-211	HS23-261	HS23-311	
Condenser Coil	Net face area (sq. ft.)	Outer coil	12.60	12.60	12.60	14.70
		Inner coil	----	----	----	----
	Tube diameter (in.) & no. of rows		3/8 — 1	3/8 — 1	3/8 — 1	3/8 — 1
	Fins per inch		20	20	20	20
Condenser Fan	Diameter (in.) & no. of blades		20 — 3	20 — 3	20 — 3	20 — 3
	Motor hp		1/6	1/6	1/6	1/6
	Cfm		2500	2500	2500	2700
	Rpm		850	850	850	850
	Watts		200	200	200	205
*Refrigerant — 22 charge furnished		4 lbs. 4 oz.	4 lbs. 12 oz.	5 lbs. 5 oz.	5 lbs. 9 oz.	
Liquid line (o.d. in.) connection (sweat)		**3/8	***3/8	***3/8	3/8	
Suction line (o.d. in.) connection (sweat)		1/2	5/8	5/8	3/4	
Shipping weight (lbs.) 1 package		121	153	154	168	

*Refrigerant charge sufficient for 20 ft. length of refrigerant lines.

**3/8" x 1/4" reducer furnished to adapt to 1/4 field fabricated line set.

***3/8" x 5/16" reducer furnished to adapt unit to 5/16" line set.

SPECIFICATIONS (contd.)

Model No.		HS23-411/HS23-413	HS23-461/HS23-463	HS23-511/HS23-513	HS23-651/HS23-653	
Condenser Coil	Net face area (sq. ft.)	Outer coil	14.70	14.70	20.00	20.00
		Inner coil	----	9.80	----	15.40
	Tube diameter (in.) & no. of rows		3/8 — 1	3/8 — 1.67	3/8 — 1	3/8 — 1.77
	Fins per inch		20	20	20	20
Condenser Fan	Diameter (in.) & no. of blades		20 — 3	20 — 3	24 — 4	24 — 4
	Motor hp		1/6	1/6	1/4	1/4
	Cfm		2700	2450	3900	4000
	Rpm		840	840	835	830
	Watts		205	210	340	355
*Refrigerant — 22 charge furnished		5 lbs. 12 oz.	9 lbs. 3 oz. 7 lbs. 13 oz. (460-2)	8 lbs. 13 oz.	11 lbs. 2 oz.	
Liquid line (o.d. in.) connection (sweat)		3/8	3/8	3/8	3/8	
Suction line (o.d. in.) connection (sweat)		3/4	7/8	7/8	1-1/8	
Shipping weight (lbs.) 1 package		182	223 (-) 238 (-2)	238	271	

*Refrigerant charge sufficient for 20 ft. length of refrigerant lines.

ELECTRICAL DATA

Model No.		HS23-141	HS23-211	HS23-261	HS23-311-1	HS23-311-2	HS23-411
Line voltage data		208/230v 60hz-1ph					
Compressor	Rated load amps	5.0	8.6	9.8	12.2	13.7	16.3
	Power factor	.97	.97	.96	.99	.99	.99
	Locked rotor amps	26.3	49.0	56.0	71.0	75.0	86.7
Condenser Coil Fan Motor	Full load amps	1.1	1.1	1.1	1.1	1.1	1.1
	Locked rotor amps	1.7	1.7	1.7	1.7	1.7	1.7
Rec. max. fuse or circuit breaker size (amps)		15	20	20	25	30	35
*Minimum circuit ampacity		7.4	12.0	13.4	16.4	18.2	21.5

*Refer to National Electrical Code manual to determine wire, fuse and disconnect size requirements.

NOTE — Extremes of operating range are plus 10% and minus 5% of line voltage.

ELECTRICAL DATA

Model No.		HS23-413		HS23-461-1	HS23-461-2	HS23-463-1		HS23-463-2	
Line voltage data — 60hz.		208/230 3ph	460v 3ph	208/230v 1ph		208/230v 3ph	460v 3ph	208/230v 3ph	460v 3ph
Compressor	Rated load amps	11.6	5.1	22.0	20.3	14.1	7.1	11.6	5.6
	Power factor	.88	.88	.99	.97	.79	.79	.88	.88
	Locked rotor amps	65.1	32.8	105.0	107.4	130.0	64.0	73.4	37.7
Condenser Coil Fan Motor	Full load amps	1.1	0.6	1.1	1.7	1.1	0.6	1.7	1.1
	Locked rotor amps	1.7	0.9	1.7	3.1	1.7	0.9	3.1	2.2
Rec. max. fuse or circuit breaker size (amps)		25	15	50	45	30	15	25	15
*Minimum circuit ampacity		15.6	7.0	28.6	27.0	18.8	9.5	16.2	8.2

*Refer to National Electrical Code manual to determine wire, fuse and disconnect size requirements.

NOTE — Extremes of operating range are plus 10% and minus 5% of line voltage.

ELECTRICAL DATA (contd.)

Model No.		HS23-511	HS23-513		HS23-651	HS23-653	
Line voltage data — 60 hz		208/230v 1ph	208/230v 3ph	460v 3ph	208/230v 1ph	208/230v 3ph	460v 3ph
Compressor	Rated load amps	22.5	14.8	7.0	30.8	17.4	9.6
	Power factor	.97	.88	.88	.98	.79	.79
	Locked rotor amps	110.0	92.0	46.0	147.0	150.0	73.0
Condenser Coil Fan Motor	Full load amps	1.7	1.7	1.1	1.7	1.7	1.1
	Locked rotor amps	3.1	3.1	2.2	3.1	3.1	2.2
Rec. max. fuse or circuit breaker size (amps)		50	35	15	60	40	20
*Minimum circuit ampacity		30.0	20.2	9.9	40.2	23.5	13.2

*Refer to National Electrical Code manual to determine wire, fuse and disconnect size requirements.

NOTE — Extremes of operating range are plus 10% and minus 5% of line voltage.

I - UNIT INFORMATION

HS23 condensing units are available in 1, 1 -1/2, 2, 2 -1/2, 3, 3 -1/2, 4 and 5 ton capacities.

All major components (indoor blower/coil) must be matched according to Lennox recommendations for the compressor to be covered under warranty. Refer to the Engineering Handbook for approved system matchups. A misapplied system will cause erratic operation and can result in early compressor failure.

II - UNIT COMPONENTS

A - Control Box (Figures 1)

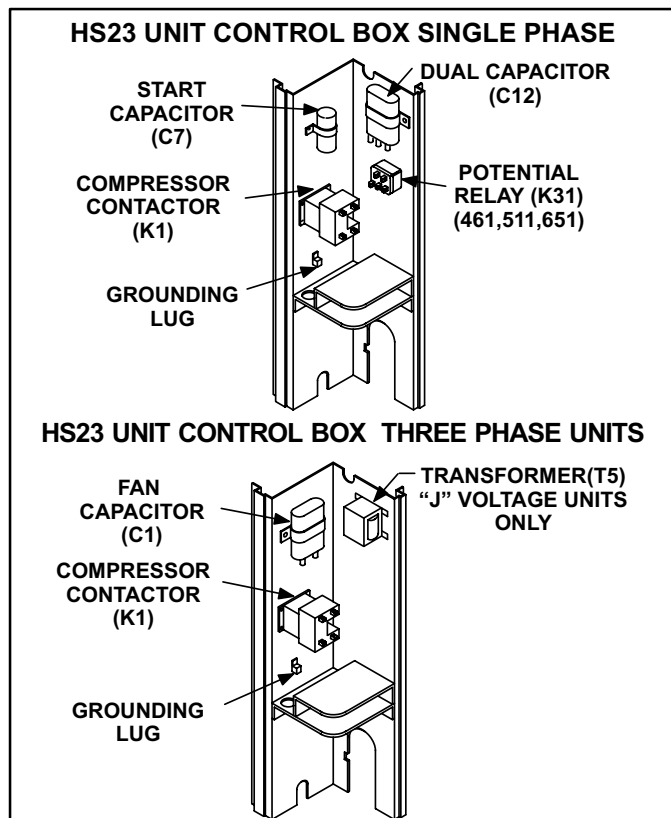

FIGURE 1

⚠ DANGER



Shock Hazard

All single phase HS23 units use single-pole contactors. One leg of compressor, capacitor and condenser fan are connected to line voltage at all times. Potential exists for electrical shock resulting in injury or death. Remove all power at disconnect before servicing. Can cause personal injury or death.

1 - Compressor Contactor K1

The compressor is energized by a contactor located in the control box. See figure 1. Contactors are SPST in single phase units and 3PST in three phase units. The contactor is energized by indoor thermostat terminal Y when thermostat demand is present.

The contactor coil is energized by 24VAC supplied by the indoor unit. All other controls in the outdoor unit are powered by line voltage. Refer to unit wiring diagram. The HS23 is not equipped with a line voltage to 24V transformer.

2 - Dual Capacitor C12

The compressor and fan in single phase units use permanent split capacitor motors. The capacitor is located inside the unit control box (see figure 1). A single "dual" capacitor (C12) is used for both the fan motor and the compressor (see unit wiring diagram). The fan side and the compressor side of the capacitor have different MFD ratings. See table 1 for dual capacitor ratings.

TABLE 1

HS23 (C12) DUAL CAPACITOR RATING				
Unit	Terminal	MFD	VAC	
HS23-141/211	FAN	5	370	
	HERM	25		
HS23-261	FAN	5		
	HERM	30		
HS23-311-1/411	FAN	5		
	HERM	45		
HS23-311-2	FAN	5		
	HERM	35		
HS23-461-1	FAN	5		440
	HERM	50		
HS23-461-2/-511	FAN	10		
	HERM	45		
HS23-651	FAN	10		
	HERM	60		

3 - Start Capacitor C7

All HS23-461, 511, 651 units use a start capacitor (C7) wired in parallel with the compressor side of the dual capacitor. The capacitor is located inside the unit control box (see figure 1). C7 is switched off by potential relay (K31) when the compressor nears full speed. See table 2 for start capacitor ratings.

TABLE 2

HS23 START CAPACITOR RATING		
Unit	MFD	VAC
HS23-461-2/-511	135-155	320
HS23-461-1/-651	189-227	330

4 - Transformer T5

Transformer T5 is used on all "J" voltage units. T5 is used as a step-down transformer for fan B4. T5 is rated at 3.4 VA with a 575 volt primary and a 460 volt secondary.

5 - Potential (Start) Relay K31

All HS23-461, 511, 651 series units use a potential relay which controls the operation of the starting circuit. The potential relay is located inside the unit control box (see figure 1). The relay is normally closed when contactor K2 is de-energized. When K1 energizes, the compressor immediately begins start-up. K31 remains closed during compressor start-up and the start capacitor remains in the circuit. As the compressor gains speed, K31 is energized. When K31 energizes, the contacts open and the start capacitor is taken out of the circuit.

6 - Fan Capacitor C1

The fan in three-phase units use permanent split capacitor motors. A single capacitor is used for the fan motor. The capacitor is located inside the unit control box (see figure 1). Table 3 shows the ratings of C1.

TABLE 3

HS23 FAN CAPACITOR RATING (C1)		
Unit	MFD	VAC
HS23-413/463-1	5	370
HS23-463-2/513/ 653Y,G	10	370
HS23-651J	10	370

B - Compressor

All units except for the -141 units utilize a conventional reciprocating style compressor.

1 - Rotary Compressor (-141 Units Only)

HS23-141 units utilize a hermetically sealed rotary-type compressor manufactured by Tecumseh Products. It is illustrated in figure 2.

The compressor has four moving parts: a rotor shaft, eccentric, roller and a blade. See figure 2.

The compressor rotor shaft is attached directly to the compressor motor. The rotor shaft is permanently attached to an eccentric. The eccentric is inside the roller and as the eccentric rotates, the roller rotates. The spring loaded blade is in continuous contact with the roller. The contact and a thin layer of oil form a seal separating the suction port from the discharge port at all times.

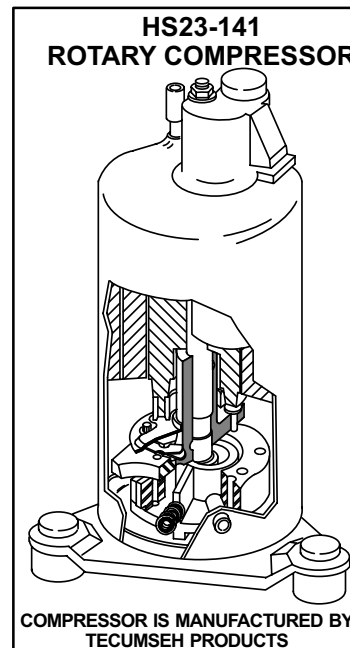

FIGURE 2

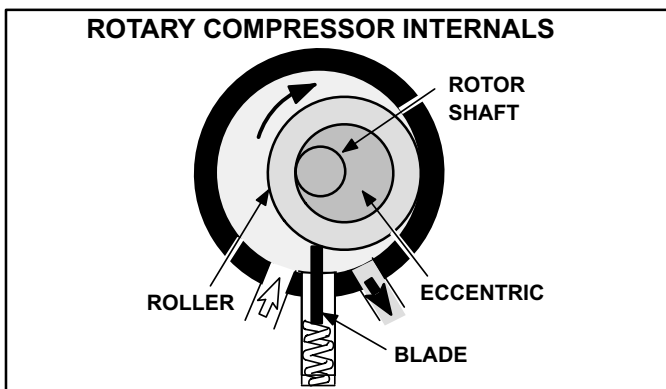

FIGURE 2

Figure 3 illustrates the four steps in a rotary compressor cycle. The spring-loaded blade is compressed fully at the beginning of an exhaust cycle. At this instant the compression is beginning (1). The roller rotates and compression continues (2). When the blade is fully extended the suction port is separated from the discharge port (3). Intake continues and the compressed vapor is discharged (4). A rotary compressor has a continuous intake cycle.

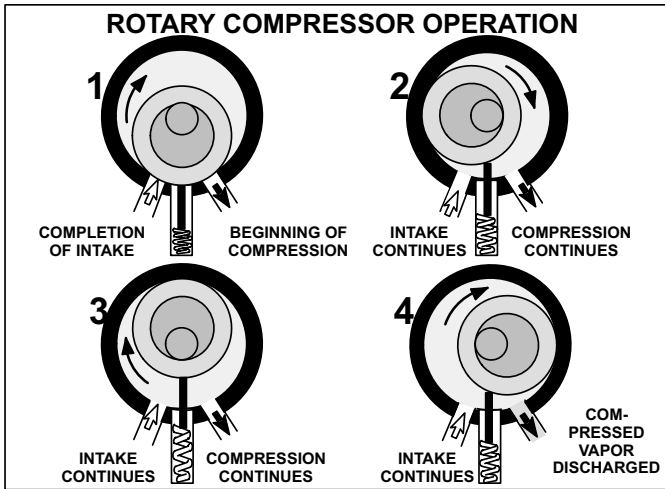

FIGURE 3

a - Suction Muffler (-141 Units Only)

All HS23-141 units are equipped with a suction muffler that is externally mounted on the compressor shell and attaches to the suction line. The muffler contains two wire mesh screen filters for added compressor protection. See figure 4.

2 - Accumulator (-141 Units Only)

All HS23-141 units are equipped with an accumulator that is mounted in the suction line. The accumulator protects the compressor from liquid slugging. See figure 4.

3 - Compressor Specifications

Table 4 shows the specifications of compressors used in HS23 series units.

TABLE 4

HS23 COMPRESSOR SPECIFICATIONS					
Unit	Voltage	Phase	LRA	RLA	Oil fl.oz.
HS23-141	208/230	1	26.3	4.8	15**
HS23-211	208/230	1	49	9.6	45*
HS23-261	208/230	1	56	10.9	45*
HS23-311-1	208/230	1	71.0	11.7	32*
HS23-311-2	208/230	1	75.0	13.7	45*
HS23-411	208/230	1	86.7	14.2	54*
HS23-413	208/230	3	65.1	9.2	54*
HS23-413	460	3	32.8	4.6	54*
HS23-461-1	208/230	1	105	16.4	70*
HS23-461-2	208/230	1	107.4	20.3	70*
HS23-463-1	208/230	3	130	11.9	70*
HS23-463-2	208/230	3	73.4	11.6	70*
HS23-463-1	460	3	64	5.6	70*
HS23-463-2	460	3	37.7	5.6	70*
HS23-511	208/230	1	110	20.5	54*
HS23-513	208/230	3	92.0	13.4	54*
HS23-513	460	3	46.0	6.7	54*
HS23-513	575	3	44.0	5.3	54*
HS23-651	208/230	1	147	24	65*
HS23-653	208/230	3	150	16	65*
HS23-653	460	3	73	8.0	65*
HS23-653	575	3	50.0	6.4	65*

*Shipped with conventional white oil (Sontex 200LT) or 3GS. 3GS oil may be used if additional oil is required.

**Shipped with 60% Zerol 300—40% Sontex 200LT. A 60/40 mixture of Zerol 300/Sontex 200LT may be used if additional oil is required.

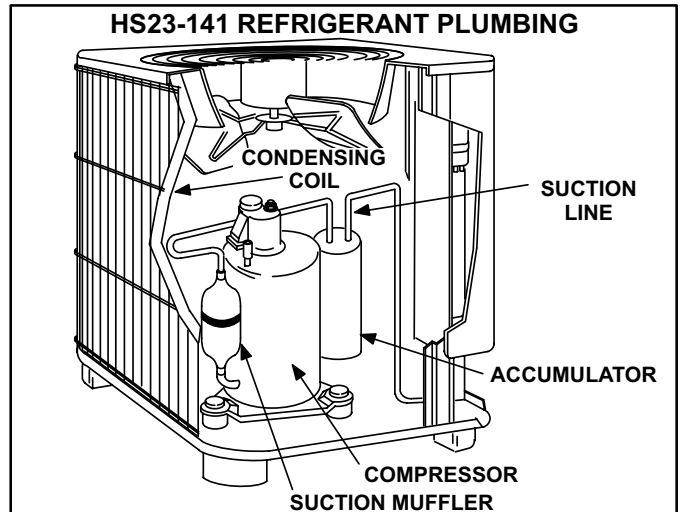

FIGURE 4

4 - Reciprocating Compressor (all other units)

All units except for the -141 units utilize a conventional reciprocating style compressor.

5 - High Pressure Limit S4

A manual-reset single-pole single-throw high pressure switch located in the discharge line of the compressor shuts off the compressor when discharge pressure rises above the factory setting. The switch is normally closed and is permanently adjusted to trip (open) at 410 ± 10 psi. See figure 5 for reset switch location.

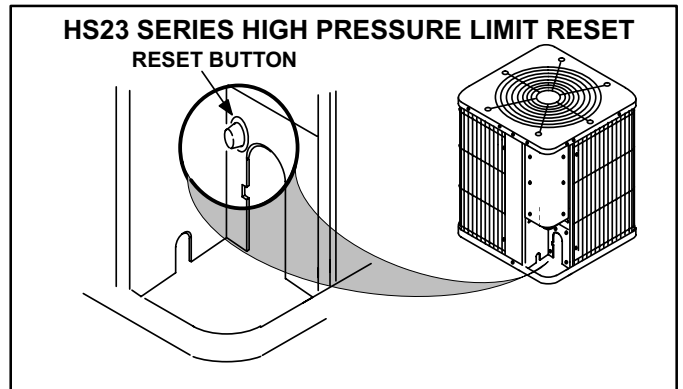

FIGURE 5

6 - Low Pressure Limit S87

A self-resetting single-pole single-throw low pressure switch located in the suction line of the compressor shuts off the compressor (switch opens) when suction line pressure drops below 25psi. At 50 to 55psi the switch automatically resets (switch closes). This is a safety shut-down function of the unit.

7 - Crankcase Heater

A crankcase heater is used on all HS23-510 through HS23-650 models. The well-mounted insertion-type heater is self-regulating. Heaters are rated at 27 watts for HS23-511/513 and 30 watts for HS23-651/653. The heater is temperature-actuated and operates only when required.

8 - Compressor Cover (Figure 6)

A compressor cover constructed of vinyl-faced fiberglass is used on all HS23-261 through -650 units. The cover provides an acoustic barrier. The cover slides over the compressor and is held secure with velcro™ straps. Slits are provided for installation around the discharge and suction lines.

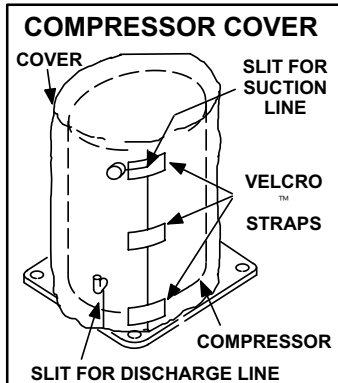

FIGURE 6

C - Condenser Fan Motor

All units use single-phase PSC fan motors which require a run capacitor. The table on page 1 of this manual shows the specifications of condenser fans used in HS23s. In all units, the condenser fan is controlled by the compressor contactor.

Two different mounting arrangements are used (fan motor up and fan up) see figures 7 and 8.

Access to the condenser fan motor on all units is gained by removing the six (6) screws securing the fan guard. See figures 7 and 8.

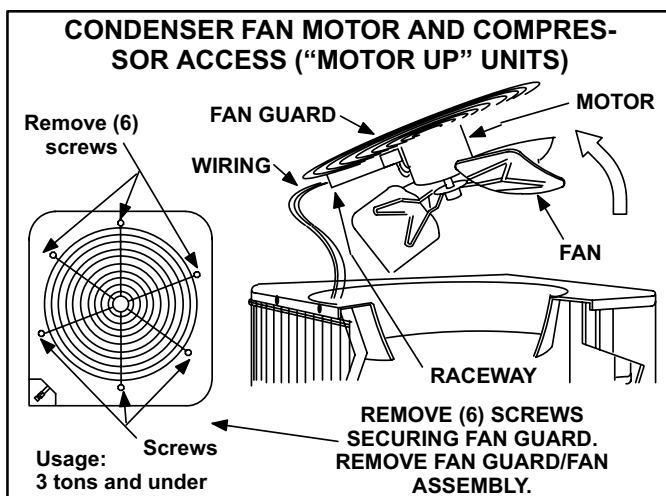

FIGURE 7

The condenser fan motor is attached to the fan guard on "motor up" units and is removed with the fan guard. See figure 8.

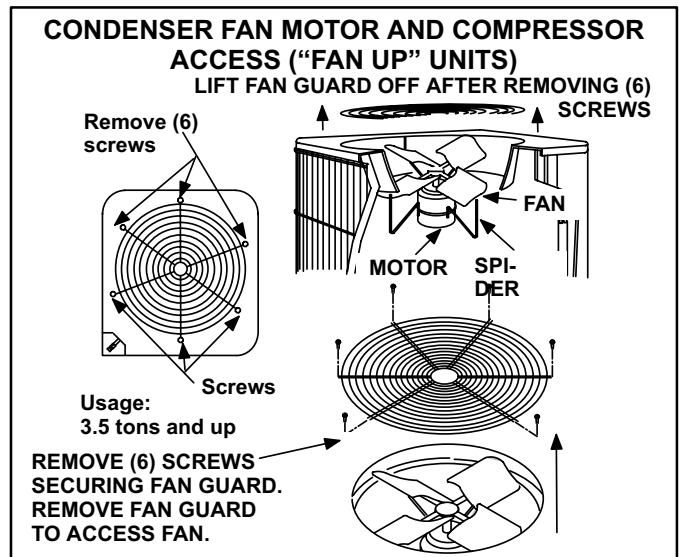

FIGURE 8

III - REFRIGERANT SYSTEM A - Plumbing

Field refrigerant piping consists of liquid and suction lines from the outdoor unit (sweat connections). Use Lennox L10 series line sets as shown in table 5 or field fabricated refrigerant lines.

Separate discharge and suction service ports are provided outside the unit for connection of gauge manifold during charging procedure.

TABLE 5

LINE SET SPECIFI-				
Condensing Unit Model No.	CAUTIONS Set Model No.	Length of Suct. & Liq. Lines (ft.)	Liquid Line (o.d. ft.)	Suction Line (o.d. ft.)
HS23-141	*Not Available	---	**1/4	1/2
HS23-211	L10-21-20	20	***5/16	5/8
	L10-21-25	25	***5/16	5/8
HS23-261	L10-21-35	35	***5/16	+5/8
	L10-21-50	50	***5/16	+5/8
HS23-311	L10-41-20	20	3/8	3/4
	L10-41-30	30	3/8	3/4
HS23-410	L10-41-40	40	3/8	3/4
	L10-41-50	50	3/8	3/4
HS23-460	L10-65-30	30	3/8	7/8
	L10-65-40	40	3/8	7/8
HS23-510	L10-65-50	50	3/8	7/8
HS23-651	*Not Available	---	3/8	1-1/8

*Field Fabricate

**3/8" x 1/4" reducer furnished to adapt unit to 1/4 field fabricated line set.

*** 3/8" x 5/16" reducer furnished to adapt unit to 5/16" line set.

B - Service Valves

The liquid line and suction line service valves and gauge ports are accessible from outside of the unit. Full service liquid and suction line valves are used. See figures 9 and 10. The service ports are used for leak testing, evacuating, charging and checking charge.

1 - Liquid Line Service Valve

A full service liquid line valve is used on all HS23 series units. Different manufacturers of valves may be used. All liquid line service valves function the same way, differences are in construction.

Valves manufactured by Parker are forged assemblies. Valves manufactured by Primore are brazed together. Valves are not rebuildable. Defective valves must be replaced. The liquid line service valve is illustrated in figure 9.

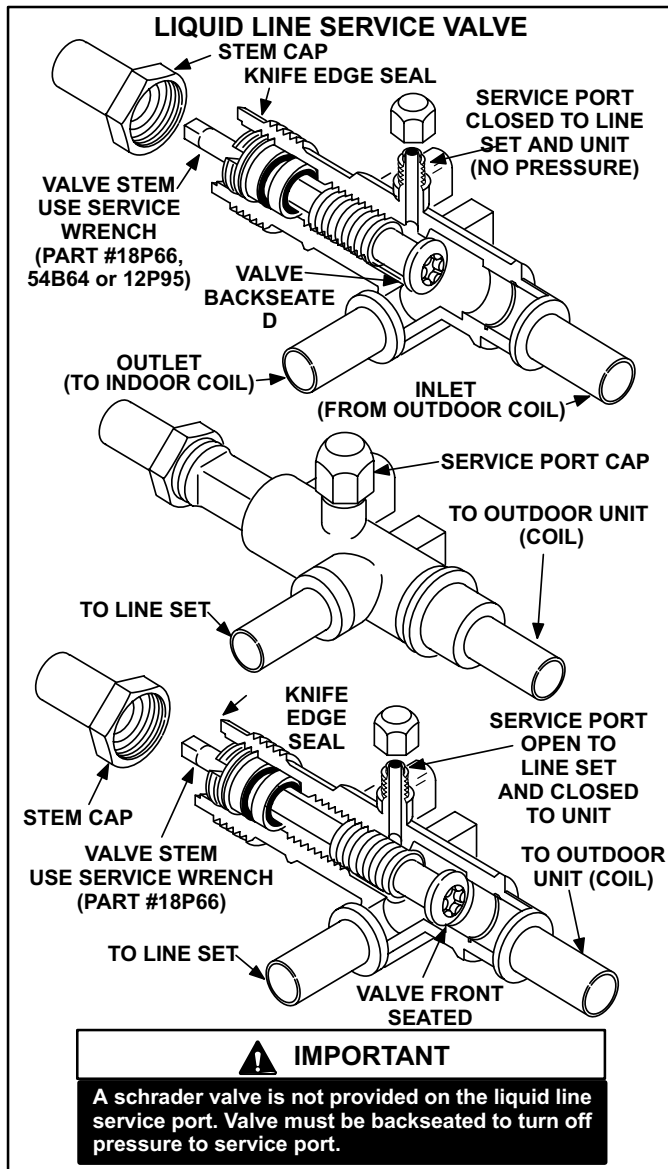

FIGURE 9

The valve is equipped with a service port. There is no schrader valve installed in the liquid line service port. A service port cap is supplied to seal off the port.

The liquid line service valve is a front and back seating valve. When the valve is backseated the service port is isolated from the system.

! IMPORTANT
A schrader valve is not provided on the liquid line service port. Valve must be backseated to turn off pressure to service port.

! CAUTION

The service port cap is used to seal the liquid line service valve. Access to service port requires backseating the service valve to isolate the service port from the system. Failure to do so will cause refrigerant leakage.

To Access Service Port:

- 1 - Remove the stem cap. Use a service wrench (part #18P66, 54B64 or 12P95) to make sure the service valve is backseated.
- 2 - Remove service port cap and connect high pressure gauge to service port.
- 3 - Using service wrench, open valve stem (one turn clockwise) from backseated position.
- 4 - When finished using port, backseat stem with service wrench. Tighten firmly.
- 5 - Replace service port and stem cap. Tighten finger tight, then tighten an additional 1/6 turn.

To Close Off Service Port:

- 1 - Using service wrench, backseat valve.
 - a - Turn stem counterclockwise.
 - b - Tighten firmly.

To Open Liquid Line Service Valve:

- 1 - Remove the stem cap with an adjustable wrench.
- 2 - Using service wrench, backseat valve.
 - a - Turn stem counterclockwise until backseated.
 - b - Tighten firmly.
- 3 - Replace stem cap, finger tighten then tighten an additional 1/6 turn.

To Close Liquid Line Service Valve:

- 1 - Remove the stem cap with an adjustable wrench.
- 2 - Turn the stem in clockwise with a service wrench to front seat the valve. Tighten firmly.
- 3 - Replace stem cap, finger tighten then tighten an additional 1/6 turn.

2 - Suction Line Service Valve

A full service suction line service valve is used on all HS23 series units. Suction valves are non-backseating type. Three different manufacturers of valves may be used. All suction line service valves function the same way, differences are in construction. Valves manufactured by Aeroquip and Parker are forged assemblies. Valves manufactured by Primore are brazed together. Valves are not rebuildable. Defective valves must be replaced. The suction line service valve is illustrated in figures 10 and 11.

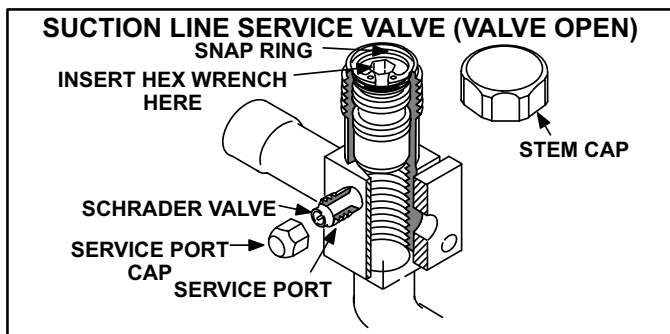

FIGURE 10

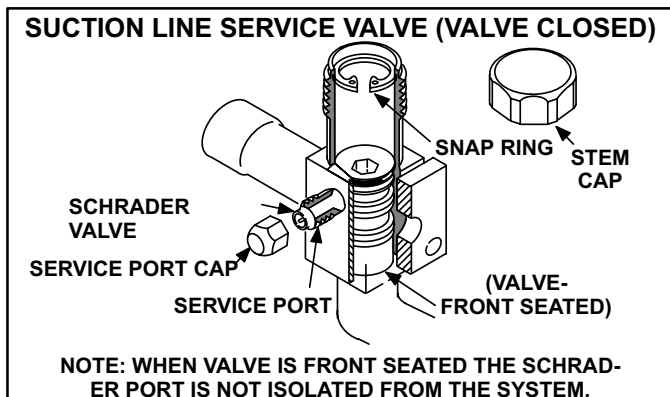

FIGURE 11

The valve is equipped with a service port. A schrader valve is factory installed. A service port cap is supplied to protect the schrader valve from contamination and assure a leak free seal.

The suction line service valve is a front-seating valve and does not backseat.

To Access Schrader Port:

- 1 - Remove service port cap with an adjustable wrench.
- 2 - Connect gauge to the service port.
- 3 - When testing is completed, replace service port cap. Tighten finger tight, then an additional 1/6 turn.

⚠ DANGER

Do not attempt to backseat this valve. Attempts to backseat this valve will cause snap ring to explode from valve body under pressure of refrigerant. Personal injury and unit damage will result.

To Open Suction Line Service Valve:

- 1 - Remove stem cap with an adjustable wrench.
- 2 - Using service wrench and 5/16" hex head extension (part #49A71) back the stem out counterclockwise until the valve stem just touches the retaining ring.
- 3 - Replace stem cap tighten firmly. Tighten finger tight, then tighten an additional 1/6 turn.

To Close Suction Line Service Valve:

- 1 - Remove stem cap with an adjustable wrench.

- 2 - Using service wrench and 5/16" hex head extension (part #49A71) turn stem in clockwise to seat the valve. Tighten firmly.
- 3 - Replace stem cap. Tighten finger tight, then tighten an additional 1/6 turn.

IV - CHARGING

The unit is factory-charged with the amount of R-22 refrigerant indicated on the unit rating plate. This charge is based on a matching indoor coil and outdoor coil with a 20 foot (6096mm) line set. For varying lengths of line set, refer to table 6 for refrigerant charge adjustment. A blank space is provided on the unit rating plate to list actual field charge.

TABLE 6

LIQUID LINE SET DIAMETER	Ounce per 5 foot (ml per mm) adjust from 20 foot (6096 mm) line set*
1/4 in. (6 mm)	1 ounce per 5 feet (30 ml per 1524 mm)
5/16 in. (8mm)	2 ounce per 5 feet (60 ml per 1524 mm)
3/8 in. (10 mm)	3 ounce per 5 feet (90 ml per 1524 mm)

*If line set is greater than 20 ft. (6.09m) add this amount. If line set is less than 20 feet (6.09m) subtract this amount

Units are designed for line sets up to 50ft. Consult Lennox Refrigerant Piping Manual for line sets over 50ft.

⚠ IMPORTANT

If line length is greater than 20 feet (6096mm), add this amount. If line length is less than 20 feet (6096 mm), subtract this amount.

A - Leak Testing

- 1- Attach gauge manifold and connect a drum of dry nitrogen to center port of gauge manifold.

⚠ CAUTION

When using dry nitrogen, a pressure reducing regulator must be used to prevent excessive pressure in gauge manifold, connecting hoses, and within the system. Regulator setting must not exceed 150 psig (1034 kpa). Failure to use a regulator can cause equipment failure resulting in injury.

- 2- Open high pressure valve on gauge manifold and pressurize line set and indoor coil to 150 psig (1034 kPa).
- 3- Check lines and connections for leaks.
NOTE-If electronic leak detector is used, add a trace of refrigerant to the nitrogen for detection by leak detector.
- 4- Release nitrogen pressure from the system, correct any leaks and recheck.

B - Evacuating the System

- 1- Attach gauge manifold. Connect vacuum pump (with vacuum gauge) to center port of gauge manifold. With both manifold service valves open, start pump and evacuate indoor coil and refrigerant lines.

⚠ IMPORTANT

A temperature vacuum gauge, mercury vacuum (U-tube), or thermocouple gauge should be used. The usual Bourdon tube gauges are not accurate enough in the vacuum range.

⚠ IMPORTANT

The compressor should never be used to evacuate a refrigeration or air conditioning system.

- 2- Evacuate the system to 29 inches (737mm) vacuum. During the early stages of evacuation, it is desirable to stop the vacuum pump at least once to determine if there is a rapid loss of vacuum. A rapid loss of vacuum would indicate a leak in the system and a repeat of the leak testing section would be necessary.
- 3- After system has been evacuated to 29 inches (737mm), close gauge manifold valves to center port, stop vacuum pump and disconnect from gauge manifold. Attach an upright nitrogen drum to center port of gauge manifold and open drum valve slightly to purge line at manifold. Break vacuum in system with nitrogen pressure by opening manifold high pressure valve. Close manifold high pressure valve to center port.
- 4- Close nitrogen drum valve and disconnect from gauge manifold center port. Release nitrogen pressure from system.
- 5- Connect vacuum pump to gauge manifold center port. Evacuate system through manifold service valves until vacuum in system does not rise above 29.7 inches (754mm) mercury (5mm absolute pressure) within a 20-minute period after stopping vacuum pump.
- 6- After evacuation is complete, close manifold center port, and connect refrigerant drum. Pressurize system slightly with refrigerant to break vacuum.

C - Charging

If the system is completely void of refrigerant, the recommended and most accurate method of charging is to weigh the refrigerant into the unit according to the total amount shown on the unit nameplate. Also refer to the SPECIFICATIONS tables on pages 1 and 2.

If weighing facilities are not available or if unit is just low on charge, the following procedure applies.

1 - Expansion Valve Systems

The following procedures are intended as a general guide for use with expansion valve systems only. For best results, indoor temperature should be between 70 °F and 80 °F. Outdoor temperature should be 60 °F or above. Slight variations in charging temperature and pressure should be expected. Large variations may indicate a need for further servicing.

⚠ IMPORTANT

The following procedure requires accurate readings of ambient (outdoor) temperature, liquid temperature and liquid pressure for proper charging. Use a thermometer with accuracy of ± 2 °F and a pressure gauge with accuracy of ± 5 PSIG.

APPROACH METHOD (TXV SYSTEMS)

(Ambient Temperature of 60° F [16° C] or Above)

- 1 - Connect gauge manifold. Connect an upright R-22 drum to center port of gauge manifold.
- 2 - Record outdoor air (ambient) temperature.
- 3 - Operate indoor and outdoor units in cooling mode. Allow outdoor unit to run until system pressures stabilize.
- 4 - Make sure thermometer well is filled with mineral oil before checking liquid line temperature.
- 5 - Place thermometer in well and read liquid line temperature. Liquid line temperature should be a few degrees warmer than the outdoor air temperature. Table 7 shows how many degrees warmer the liquid line temperature should be.
Add refrigerant to make the liquid line temperature cooler.
Recover refrigerant to make the liquid line temperature warmer.

TABLE 7

APPROACH METHOD - EXPANSION VALVE SYSTEMS	
Model	Liquid Line °F Warmer Than Outside (Ambient) Temperature
HS23-141	1±1
HS23-211	5±1
HS23-261	4±1
HS23-311	8±1
HS23-410	10±1
HS23-460-1	16±1
HS23-460-2/510	7±1
HS23-650	10±1

- 6 - When unit is properly charged liquid line pressures should approximate those given in table 8.

⚠ IMPORTANT

Use table 8 as a general guide for performing maintenance checks. Table 8 is not a procedure for charging the system. Minor variations in these pressures may be expected due to differences in installations. Significant deviations could mean that the system is not properly charged or that a problem exists with some component in the system. Used prudently, table 8 could serve as a useful service guide.

TABLE 8

NORMAL OPERATING PRESSURES																			
OUTDOOR COIL ENTERING AIR TEMPERATURE	HS23-141		HS23-211		HS23-261		HS23-311		HS23-410		HS23-460-1		HS23-460-2		HS23-510		HS23-650		
	LIQ.	SUC.	LIQ.	SUC.	LIQ.	SUC.	LIQ.	SUC.	LIQ.	SUC.	LIQ.	SUC.	LIQ.	SUC.	LIQ.	SUC.	LIQ.	SUC.	
	± 10 PSIG	± 10 PSIG	± 10 PSIG	± 10 PSIG	± 10 PSIG	± 10 PSIG	± 10 PSIG	± 10 PSIG	± 10 PSIG	± 10 PSIG	± 10 PSIG	± 10 PSIG	± 10 PSIG	± 10 PSIG	± 10 PSIG	± 10 PSIG	± 10 PSIG	± 10 PSIG	± 10 PSIG
65° F (RFCII)	126	52	137	56	142	59	154	58	158	58	166	56	159	61	146	60	152	55	
75° F (RFCII)	149	64	161	64	168	66	181	64	185	64	191	65	186	67	167	66	179	62	
85° F (RFCII)	178	71	188	71	194	72	210	70	218	70	223	71	204	70	200	71	206	67	
95° F (RFCII)	208	78	216	77	220	78	238	75	250	75	255	77	246	76	231	75	233	72	
105° F (RFCII)	236	83	252	80	253	81	276	78	283	77	294	80	280	79	261	79	278	75	
65° F (TXV)	126	58	133	60	140	63	151	61	164	60	163	58	160	63	146	63	147	59	
75° F (TXV)	149	70	157	68	164	70	178	67	191	66	188	67	188	69	167	69	174	66	
85° F (TXV)	178	77	184	75	190	76	207	73	218	72	220	73	202	73	200	74	201	71	
95° F (TXV)	208	79	214	77	221	78	238	75	251	74	255	78	242	76	231	76	233	73	
105° F (TXV)	236	84	250	80	254	81	276	78	292	77	294	81	288	80	261	80	278	76	

2 - RFCII Systems

The following procedures are intended as a general guide for use with RFCII systems only. For best results, indoor temperature should be between 70 °F and 80 °F. Outdoor temperature should be 60 °F or above. Slight variations in charging temperature and pressure should be expected. Large variations may indicate a need for further servicing.

- 1 - Connect gauge manifold. Connect an upright R-22 drum to center port of gauge manifold.
- 2 - Operate indoor and outdoor units. Allow outdoor unit to run until system pressures stabilize.
- 3 - Make sure thermometer well is filled with mineral oil before checking liquid line temperature.
- 4 - Read liquid line pressure and convert to condensing temperature using temperature/ pressure conversion chart.
Condensing temperature (read from gauges) should be a few degrees warmer than the liquid line temperature.
- 5 - Place thermometer in well and read liquid line temperature. Table 9 shows how much warmer the condensing temperature should be.

Add refrigerant to make the liquid line temperature cooler.

Recover refrigerant to make the liquid line temperature warmer.

- 7 - When unit is properly charged liquid line pressures should approximate table 8.

D - Oil Charge

Refer to Table 4 on page 3.

V - MAINTENANCE

At the beginning of each heating or cooling season, the system should be cleaned as follows:

A - Outdoor Unit

- 1 - Clean and inspect condenser coil. (Coil may be flushed with a water hose).
- 2 - Visually inspect all connecting lines, joints and coils for evidence of oil leaks.

! IMPORTANT

If insufficient heating or cooling occurs, the unit should be gauged and refrigerant charge checked.

B - Indoor Coil

- 1 - Clean coil if necessary.
- 2 - Check connecting lines and coil for evidence of oil leaks.
- 3 - Check condensate line and clean if necessary.

C - Indoor Unit

- 1 - Clean or change filters.
- 2 - Adjust blower cooling speed. Static pressure drop over coil should be checked to determine correct blower CFM. Refer to Lennox Engineering Handbook.
- 3 - Belt Drive Blowers - Check condition/tension.
- 4 - Check all wiring for loose connections.
- 5 - Check for correct voltage at unit.
- 6 - Check amp-draw on blower motor.
Unit nameplate _____ Actual _____.

TABLE 9

SUBCOOLING METHOD									
Outdoor Temp. (°F)	Condensing Temp °F Warmer Than Liquid Line (± 1 °F)								
	-141	-211	-261	-311	-410	-460-1	-460-2	-510	-650
60	9	11	14	13	15	15	17	20	17
65	8	11	14	12	14	15	17	19	16
70	7	10	13	12	13	14	16	19	16
75	7	10	13	11	12	14	16	18	15
80	6	9	12	11	11	13	15	18	15
85	6	9	12	11	10	13	15	17	14
90	5	8	11	10	9	12	15	17	14
95	4	8	11	10	8	12	14	16	13
100	4	7	10	9	6	11	13	15	13
105	3	6	10	8	5	10	12	15	12
110	3	6	9	8	4	10	11	14	11
115	2	5	8	7	2	9	10	13	10

- 6 - Subtract liquid line temperature from condensing temperature to determine subcooling. Compare with table 9.

THREE PHASE OPERATING SEQUENCE

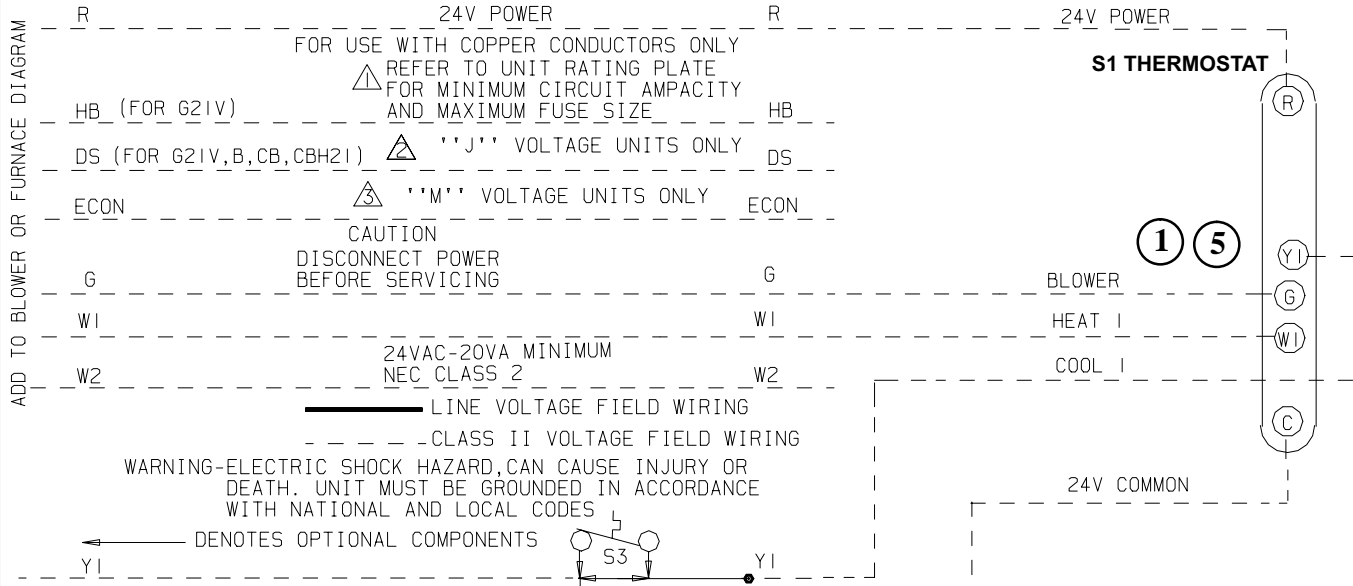

LETTER DESIGNATION	VOLTAGE
Y	208-230/60/3
G	460/60/3
J	575/60/3
M	380-420/50/3

CAUTION
DISCONNECT POWER
BEFORE SERVICING

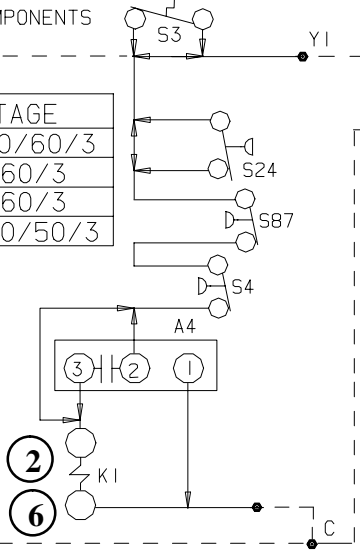

OPERATING SEQUENCE

- B-HS24 (Y, G and J Voltage) Operation Sequence**
- This is the sequence of operation for HS24 Y, G and J voltage units. The sequence is outlined by numbered steps which correspond to circled numbers on the adjacent diagram.
- NOTE-The thermostat used may be electromechanical or electronic.*
- Cooling:**
- 1- Cooling demand initiates at Y1 in the thermostat. 24VAC passes through N.C. S87 and S4.
 - 2- Compressor contactor K1 is energized
 - 3- K1-1 N.O. closes energizing terminal "C" of compressor (B1) and condenser fan motor (B4).
 - 4- Compressor (B1) and condenser fan motor (B4) begin immediate operation.
- End of Cooling Demand:**
- 5- Cooling demand is satisfied.
 - 6- Contactor K1 is de-energized.
 - 7- K1-1 opens and compressor (B1) and condenser fan motor (B4) are de-energized and stop immediately.

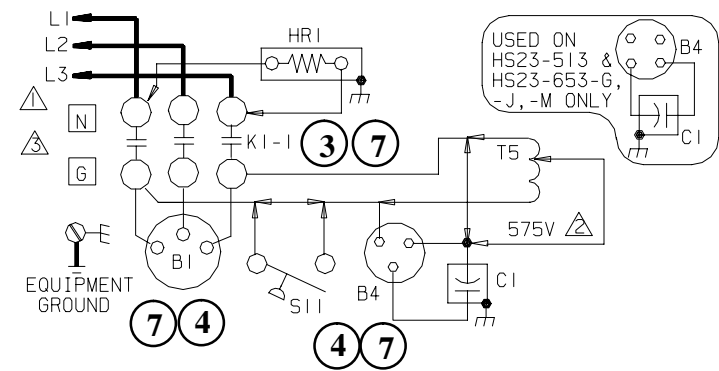

DESCRIPTION	
KEY	COMPONENT
A4	CONTROL-TIMED-OFF
B1	COMPRESSOR
B4	MOTOR-FAN
C1	CAPACITOR-OUTDOOR FAN
HRI	HEATER-COMPRESSOR
K1-, -1	CONTACTOR-COMPRESSOR
S3	LIMIT-LOW COMP. TEMP.
S4	LIMIT-HI PRESS. COMP.
S11	SWITCH-PRESS. LO AMB. KIT
S24	SWITCH-LOSS OF CHARGE
S87	SWITCH-LOW PRESS. LIMIT
T5	TRANSFORMER-OUTDOOR FAN

LENNOX® Industries Inc. WIRING DIAGRAM 11/92

COOLING UNITS-CONDENSING UNITS
 HS23-413-1-Y, G, J, M
 HS23-463-1, 2-Y, G, M
 HS23-513, 653-1-Y, G, J, M

COOLING UNITS-SEC. B
 Supersedes Form No. _____ New Form No. 529, 640W