

**HSXA15 & HSXB15 SERIES UNITS**

The HSXA15 and HSXB15 are high efficiency residential split-system condensing units, which features a scroll compressor and R410A refrigerant. HSXA15 and HSXB15 units are available in sizes ranging from 2 through 5 tons. The series is designed for use with an expansion valve only (approved for use with R410A) in the indoor unit. This manual is divided into sections which discuss the major components, refrigerant system, charging procedure, maintenance and operation sequence.

Information contained in this manual is intended for use by qualified service technicians only. All specifications are subject to change.



HSXB15 SHOWN

**⚠ IMPORTANT**  
Operating pressures of this R410A unit are higher than pressures in R22 units. Always use service equipment rated for R410A.

**⚠ WARNING**  
Improper installation, adjustment, alteration, service or maintenance can cause property damage, personal injury or loss of life. Installation and service must be performed by a qualified installer or service agency.

**⚠ DANGER**  
Electric Shock Hazard.  
May cause injury or death.  
Line voltage is present at all components when unit is not in operation on units with single pole contactors.  
Disconnect all remote electrical power supplies before opening unit panel.  
Unit may have multiple power supplies.



**⚠ IMPORTANT**  
The Clean Air Act of 1990 bans the intentional venting of (CFC's and HFC's) as of July 1, 1992. Approved methods of recovery, recycling or reclaiming must be followed. Fines and/or incarceration may be levied for noncompliance.

**TABLE OF CONTENTS**

General ..... 1

Specifications / Electrical Data ..... 2

I Application ..... 4

II Unit Components ..... 4

III Refrigerant System ..... 9

IV Charging ..... 10

V Service and Recovery ..... 12

VI Maintenance ..... 13

VII Wiring Diagrams and Operating Sequence ..... 15

## HSXA15 SPECIFICATIONS

General Data		Model No.	HSXA15-024	HSXA15-030	HSXA15-036	HSXA15-042	HSXA15-048	HSXA15-060
Nominal Tonnage (kW)			2 (7.0)	2.5 (8.8)	3 (10.6)	3.5 (12.3)	4 (14.1)	5 (17.6)
Connections (sweat)	Liquid line (o.d.) - in. (mm)		3/8 (9.5)	3/8 (9.5)	3/8 (9.5)	3/8 (9.5)	3/8 (9.5)	3/8 (9.5)
	Suction line (o.d.) - in. (mm)		3/4 (19.1)	3/4 (19.1)	3/4 (19.1)	7/8 (22.2)	7/8 (22.2)	1-1/8 (28.6)
Refrigerant	R-410A charge furnished		5 lbs. 1 oz. (2.28 kg)	5 lbs. 10 oz. (2.54 kg)	7 lbs. 8 oz. (3.39 kg)	7 lbs. 13 oz. (3.53 kg)	7 lbs. 13 oz. (3.53 kg)	10 lbs. 15 oz. (4.95 kg)
Condenser Coil	Net face area - sq. ft. (m2)	Outer coil	11.9 (1.11)	16 (1.49)	16 (1.49)	16 (1.49)	18.3 (1.70)	21.8 (2.03)
		Inner coil	5.5 (0.51)	5.6 (0.52)	13.3 (1.24)	13.3 (1.24)	13.3 (1.24)	21.1 (1.96)
		Tube diameter - in. (mm)	5/16 (7.9)	5/16 (7.9)	5/16 (7.9)	5/16 (7.9)	5/16 (7.9)	5/16 (7.9)
		No. of rows	1.46	1.35	1.83	1.83	1.73	2
		Fins per inch (m)	22 (866)	22 (866)	22 (866)	22 (866)	22 (866)	22 (866)
Condenser Fan	Diameter - in. (mm)		20 (508)	24 (610)	24 (610)	24 (610)	24 (610)	24 (610)
	No. of blades		4	3	3	3	3	3
	Motor hp (W)		1/6 (124)	1/6 (124)	1/6 (124)	1/6 (124)	1/4 (187)	1/4 (187)
	Cfm (L/s)		2450 (1115)	3150 (1485)	3150 (1485)	3150 (1485)	3900 (1840)	4200 (1980)
	Rpm		825	825	825	825	820	820
	Watts		210	225	225	225	310	350
Shipping Data (1 package)	lbs. (kg)		187 (85)	222 (101)	238 (108)	238 (108)	258 (117)	312 (142)
<b>OPTIONAL ACCESSORIES - MUST BE ORDERED EXTRA</b>								
Mounting Base	Model No.		MB2-S (69J06)	MB2-L (69J07)	MB2-L (69J07)	MB2-L (69J07)	MB2-L (69J07)	MB2-L (69J07)
	Net Weight		6 lbs. (3 kg)	15 lbs. (7 kg)	15 lbs. (7 kg)	15 lbs. (7 kg)	15 lbs. (7 kg)	15 lbs. (7 kg)
	Dimensions - in. (mm)		22-1/4x22-1/4x3 (565 x 565x76)	32 x 34 x 3 (813x864x76)	32 x 34 x 3 (813x864x76)	32 x 34 x 3 (813x864x76)	32 x 34 x 3 (813x864x76)	32 x 34 x 3 (813x864x76)

## HSXA15 ELECTRICAL DATA

General Data		Model No.	HSXA15-024 -230	HSXA15-030 -230	HSXA15-036 -230	HSXA15-042 -230	HSXA15-048 -230	HSXA15-060 -230
Line voltage data - 60hz			208/230v-1ph	208/230v-1ph	208/230v-1ph	208/230v-1ph	208/230v-1ph	208/230v-1ph
Rec. Max fuse size (amps)			30	30	35	40	45	60
☐ Minimum circuit ampacity			17.9	19.6	20.4	25.3	27.5	36.2
Compressor	Rated load amps		13.5	14.8	15.4	19.3	20.6	27.6
	Locked rotor amps		61	73	83	104	109	158
	Power factor		0.98	0.98	0.95	0.97	0.97	0.98
Condenser Fan Motor	Full load amps		1.1	1.1	1.1	1.1	1.7	1.7
	Locked rotor amps		2	2	2	2	3.1	3.1

☐ Refer to National or Canadian Electrical Code manual to determine wire, fuse and disconnect size requirements.  
NOTE — Extremes of operating range are plus 10% and minus 5% of line voltage.

## HSXB15

<b>SPECIFICATIONS</b>							
<b>General Data</b>	<b>Model No.</b>	<b>HSXB15-024 -230</b>	<b>HSXB15-030 -230</b>	<b>HSXB15-036 -230</b>	<b>HSXB15-042 -230</b>	<b>HSXB15-048 -230</b>	<b>HSXB15-060 -230</b>
	Nominal Tonnage (kW)	2 (7.0)	2.5 (8.8)	3 (10.6)	3.5 (12.3)	4 (14.1)	5 (17.6)
<b>Connections (sweat)</b>	Liquid line (o.d.) - in. (mm)	3/8 (9.5)	3/8 (9.5)	3/8 (9.5)	3/8 (9.5)	3/8 (9.5)	3/8 (9.5)
	Suction line (o.d.) - in. (mm)	3/4 (19.1)	3/4 (19.1)	3/4 (19.1)	7/8 (22.2)	7/8 (22.2)	1-1/8 (28.6)
<b>Refrigerant</b>	<sup>1</sup> R-410A charge furnished	4 lbs. 10 oz. (2.10 kg)	5 lbs. 10 oz. (2.55 kg)	7 lbs. 8 oz. (3.40 kg)	7 lbs. 13 oz. (3.54 kg)	7 lbs. 13 oz. (3.54 kg)	10 lbs. 13 oz. (4.90 kg)
<b>Condenser Coil</b>	Net face area - sq. ft. (m <sup>2</sup> ) Outer coil	11.9 (1.11)	16 (1.49)	16 (1.49)	16 (1.49)	18.3 (1.70)	21.8 (2.03)
	Inner coil	5.5 (0.51)	5.6 (0.52)	13.3 (1.24)	13.3 (1.24)	13.3 (1.24)	21.1 (1.96)
	Tube diameter - in. (mm)	5/16 (7.9)	5/16 (7.9)	5/16 (7.9)	5/16 (7.9)	5/16 (7.9)	5/16 (7.9)
	No. of rows	1.46	1.35	1.83	1.83	1.73	2
	Fins per inch (m)	22 (866)	22 (866)	22 (866)	22 (866)	22 (866)	22 (866)
<b>Condenser Fan</b>	Diameter - in. (mm)	20 (508)	24 (610)	24 (610)	24 (610)	24 (610)	24 (610)
	No. of blades	3	3	3	3	3	3
	Motor hp (W)	1/10 (75)	1/6 (124)	1/6 (124)	1/6 (124)	1/4 (187)	1/4 (187)
	Cfm (L/s)	2230 (1050)	3150 (1485)	3150 (1485)	3150 (1485)	3900 (1840)	4100 (1935)
	Rpm	825	825	825	825	820	825
	Watts	125	225	225	225	310	320
<b>Shipping Data</b>	lbs. (kg) 1 pkg.	190 (86)	227 (103)	243 (110)	243 (110)	263 (119)	317 (144)
<b>ELECTRICAL DATA</b>							
<b>General Data</b>	Line voltage data - 60hz	208/230v-1ph	208/230v-1ph	208/230v-1ph	208/230v-1ph	208/230v-1ph	208/230v-1ph
	Maximum fuse size (amps)	25	30	40	40	45	60
	<sup>2</sup> Minimum circuit ampacity	16.6	19.6	23.5	25.3	27.5	36.2
<b>Compressor</b>	Rated load amps	12.8	14.8	17.9	19.3	20.6	27.6
	Locked rotor amps	60	73	95	104	109	158
	Power factor	0.98	0.98	0.95	0.97	0.97	0.98
<b>Condenser Fan Motor</b>	Full load amps	0.6	1.1	1.1	1.1	1.7	1.7
	Locked rotor amps	1.6	2	2	2	3.1	3.1
<b>OPTIONAL ACCESSORIES - MUST BE ORDERED EXTRA</b>							
<b>CCB1 EfficiencyPlus™ Humidity Control</b>		<b>35H00</b>	<b>35H00</b>	<b>35H00</b>	<b>35H00</b>	<b>35H00</b>	<b>35H00</b>
<b>EBR1 Blower Relay Kit (for CCB1)</b>		<b>75H90</b>	<b>75H90</b>	<b>75H90</b>	<b>75H90</b>	<b>75H90</b>	<b>75H90</b>
<b>Compressor Crankcase Heater</b>	40 watt	<b>18K20</b>	<b>18K20</b>	<b>18K20</b>	<b>18K20</b>	---	---
	70 watt	<b>67K90</b>	<b>67K90</b>	<b>67K90</b>	<b>67K90</b>	<b>31J20</b>	<b>31J20</b>
<b>Compressor Hard Start Kit</b>		<b>10J42</b>	<b>10J42</b>	<b>10J42</b>	<b>10J42</b>	<b>10J42</b>	<b>81J69</b>
<b>Low Ambient Kit</b>		<b>34M72</b>	<b>34M72</b>	<b>34M72</b>	<b>34M72</b>	<b>34M72</b>	<b>34M72</b>
<b>Mounting Base</b>	Model No.	<b>MB2-S (69J06)</b>	<b>MB2-L (69J07)</b>	<b>MB2-L (69J07)</b>	<b>MB2-L (69J07)</b>	<b>MB2-L (69J07)</b>	<b>MB2-L (69J07)</b>
	Net Weight	6 lbs. (3 kg)	15 lbs. (7 kg)	15 lbs. (7 kg)	15 lbs. (7 kg)	15 lbs. (7 kg)	15 lbs. (7 kg)
	Dimensions - in. (mm)	22-1/4x22-1/4x3 (565 x 565x76)	32 x 34 x 3 (813x864x76)	32 x 34 x 3 (813x864x76)	32 x 34 x 3 (813x864x76)	32 x 34 x 3 (813x864x76)	32 x 34 x 3 (813x864x76)
<b>Refrigerant Line Set</b>	15 ft. (4.6 m) length	L15-41-15	L15-41-15	L15-41-15	L15-65-15	L15-65-15	Field Fabricate
	30 ft. (9 m) length	L15-41-30	L15-41-30	L15-41-30	L15-65-30	L15-65-30	Field Fabricate
	40 ft. (12 m) length	L15-41-40	L15-41-40	L15-41-40	L15-65-40	L15-65-40	Field Fabricate
	50 ft. (15 m) length	L15-41-50	L15-41-50	L15-41-50	L15-65-50	L15-65-50	Field Fabricate

<sup>1</sup>Refrigerant charge sufficient for 15 ft. (4.6 m) length of refrigerant lines.

<sup>2</sup>Refer to National or Canadian Electrical Code manual to determine wire, fuse and disconnect size requirements.

NOTE — Extremes of operating range are plus 10% and minus 5% of line voltage.

## I-APPLICATION

All major components (indoor blower and coil) must be matched according to Lennox recommendations for the compressor to be covered under warranty. Refer to the Engineering Handbook for approved system matchups. A misapplied system will cause erratic operation and can result in early compressor failure.

## II-Unit Components

The contactor coil, time delay (HSXA15-1 units only) and Lennox system operation monitor are energized by 24VAC supplied by the indoor unit. All other components in the outdoor unit are powered by line voltage. Refer to unit wiring diagram. The HSXA15 and HSXB15 units are not equipped with an internal line voltage to 24V transformer.

## A-Scroll Compressor (B1)

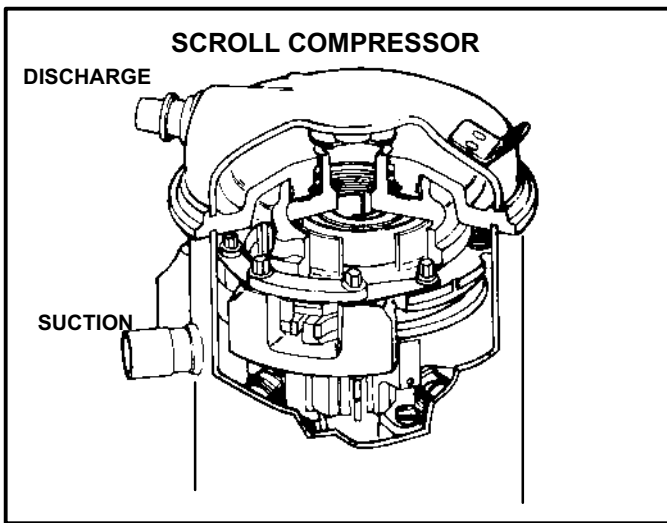

FIGURE 1

The scroll compressors in all units are designed for use with R410A refrigerant and operation at high pressures. Compressors are shipped from the factory with 3MA (32MMMA) P.O.E. oil.. See electrical section in this manual for compressor specifications.

The scroll compressor design is simple, efficient and requires few moving parts. A cutaway diagram of the scroll compressor is shown in figure 1. The scrolls are located in the top of the compressor can and the motor is located just below. The oil level is immediately below the motor.

The scroll is a simple compression concept centered around the unique spiral shape of the scroll and its inherent properties. Figure 2 shows the basic scroll form. Two identical scrolls are mated together forming concentric spiral shapes (figure 3). One scroll remains stationary, while the other is allowed to "orbit" (figure 4). Note that the orbiting scroll does not rotate or turn but merely "orbits" the stationary scroll.

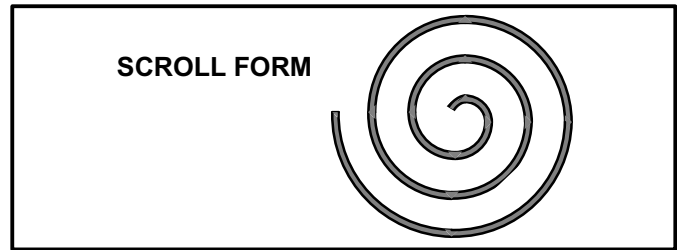

FIGURE 2

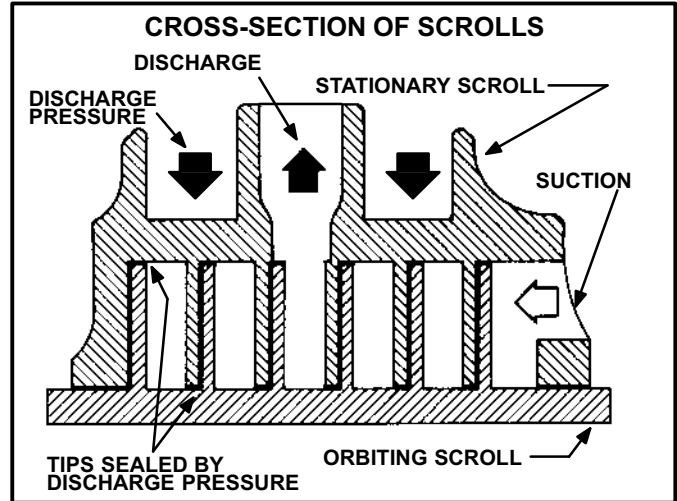

FIGURE 3

The counterclockwise orbiting scroll draws gas into the outer crescent shaped gas pocket created by the two scrolls (figure 4 - 1). The centrifugal action of the orbiting scroll seals off the flanks of the scrolls (figure 4 - 2). As the orbiting motion continues, the gas is forced toward the center of the scroll and the gas pocket becomes compressed (figure 4 - 3). When the compressed gas reaches the center, it is discharged vertically into a chamber and discharge port in the top of the compressor (figure 1). The discharge pressure forcing down on the top scroll helps seal off the upper and lower edges (tips) of the scrolls (figure 3). During a single orbit, several pockets of gas are compressed simultaneously providing smooth continuous compression.

The scroll compressor is tolerant to the effects of liquid return. If liquid enters the scrolls, the orbiting scroll is allowed to separate from the stationary scroll. The liquid is worked toward the center of the scroll and is discharged. If the compressor is replaced, conventional Lennox cleanup practices must be used.

Due to its efficiency, the scroll compressor is capable of drawing a much deeper vacuum than reciprocating compressors. Deep vacuum operation can cause internal fusite arcing resulting in damaged internal parts and will result in compressor failure. Never use a scroll compressor for evacuating or "pumping-down" the system. This type of damage can be detected and will result in denial of warranty claims.

*NOTE - During operation, the head of a scroll compressor may be hot since it is in constant contact with discharge gas.*

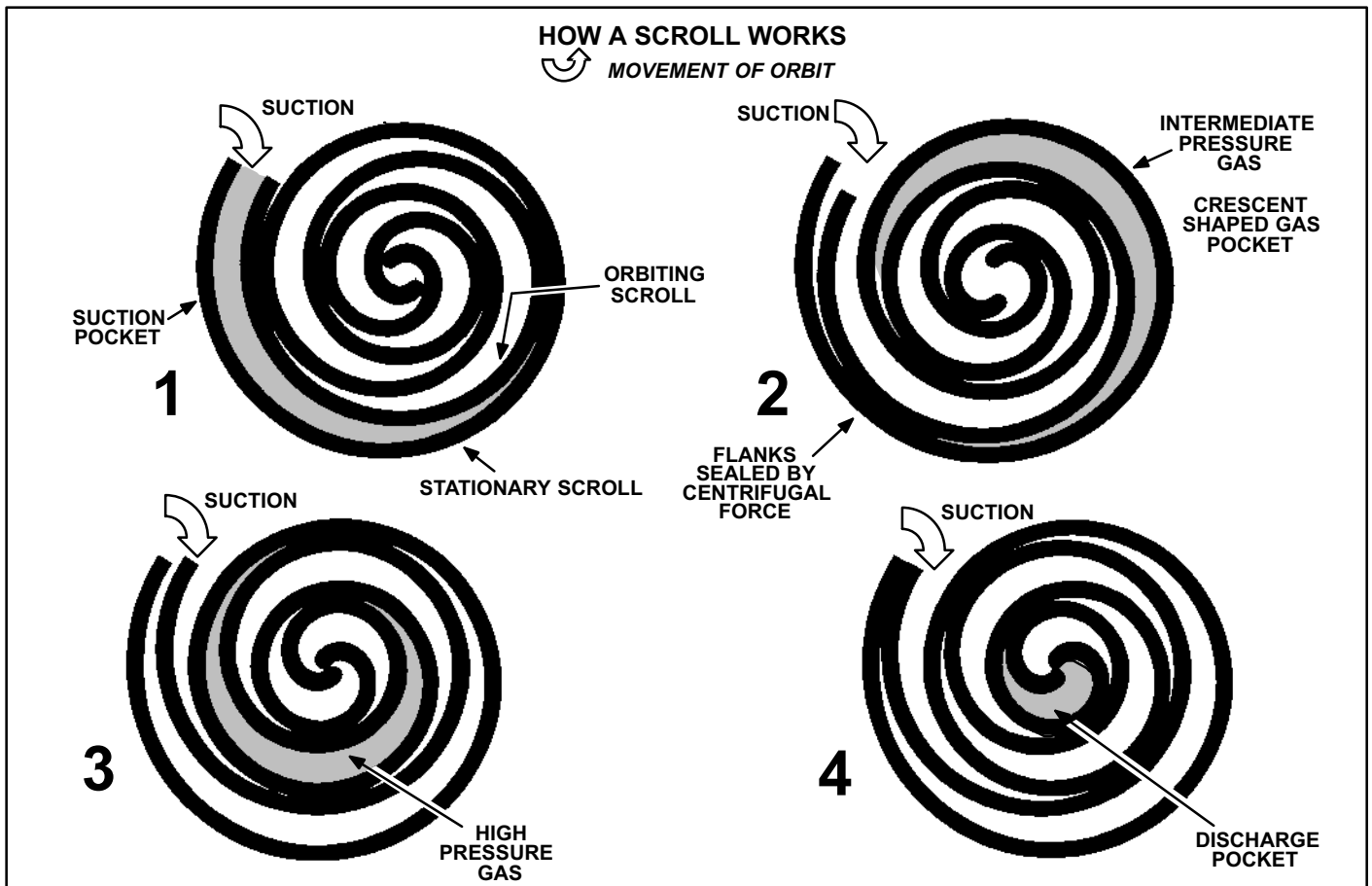

**FIGURE 4**

### B-High Pressure Switch (S4)

**⚠ IMPORTANT**

**Pressure switch settings for R410A refrigerant will be significantly higher than units with R22.**

A manual-reset, single-pole/single-throw high pressure switch is located in the liquid line. This switch shuts off the compressor when liquid line pressure rises above the factory setting. The switch is normally closed and is permanently adjusted to trip (open) at  $640 \pm 10$  psi and reset (close) at  $448 \pm 10$  psi. See figure 5 for switch location.

### C-Low Pressure Switch (S87)

An auto-reset, single-pole/single-throw low pressure switch is located in the suction line. This switch shuts off the compressor when suction pressure drops below the factory setting. The switch is closed during normal operating pressure conditions and is permanently adjusted to trip (open) at  $40 \pm 5$  psi. The switch automatically resets when suction line pressure rises above  $90 \pm 5$  psi. See figure 5 for switch location.

### D-Lennox System Operation Monitor (A132) (HSXB15 Only)

The Lennox system operation monitor (LSOM) is a 24 volt powered module, wired directly to the indoor unit. The LSOM is located in the control box and is used to troubleshoot problems in the system. The module has three LED's for troubleshooting: GREEN indicates power status, YELLOW indicates an abnormal condition and RED indicates thermostat demand, but compressor not operating. See table 1 for troubleshooting codes.

*NOTE - The LSOM is not a safety component and cannot shut down or control the HSXB15. The LSOM is a monitoring device only.*

**ELECTROSTATIC DISCHARGE (ESD)  
Precautions and Procedures**

**⚠ CAUTION**

**Electrostatic discharge can affect electronic components. Take precautions during unit installation and service to protect the unit's electronic controls. Precautions will help to avoid control exposure to electrostatic discharge by putting the unit, the control and the technician at the same electrostatic potential. Neutralize electrostatic charge by touching hand and all tools on an unpainted unit surface before performing any service procedure.**

**TABLE 1  
Lennox System Operation Monitor Troubleshooting Codes**

Status LED	Status LED Description	Status LED Troubleshooting Information
<b>Green "Power"</b>	Module has power.	Supply voltage is present at module terminals.
<b>Red "Trip"</b>	Thermostat demand signal Y1 is present, but the compressor is not running. Heat pump only - Trip light will be on during defrost board 5 minute delay with Y thermostat call.	<ol style="list-style-type: none"> <li>1 Compressor protector is open.</li> <li>2 Outdoor unit power disconnect is open.</li> <li>3 Compressor circuit breaker or fuse(s) is open.</li> <li>4 Broken wire or connector is not making contact.</li> <li>5 Low pressure switch open if present in the system.</li> <li>6 Compressor contactor has failed to close.</li> </ol>
<b>Yellow "Alert"</b> <b>Flash Code 1</b> (Does not apply to heat pump or to two-stage split systems)	<b>Long Run Time</b> Compressor is running extremely long run cycles	<ol style="list-style-type: none"> <li>1 Low refrigerant charge.</li> <li>2 Evaporator blower is not running.</li> <li>3 Evaporator coil is frozen.</li> <li>4 Faulty metering device.</li> <li>5 Condenser coil is dirty</li> <li>6 Liquid line restriction (filter drier blocked if present)</li> <li>7 Thermostat is malfunctioning.</li> </ol>
<b>Yellow "Alert"</b> <b>Flash Code 2</b>	<b>System Pressure Trip</b> Discharge or suction pressure out of limits or compressor overloaded	<ol style="list-style-type: none"> <li>1 High head pressure.</li> <li>2 Condenser coil poor air circulation (dirty, blocked, damaged).</li> <li>3 Condenser fan is not running.</li> <li>4 Return air duct has substantial leakage.</li> <li>5 If low pressure switch is present, check Flash Code 1 information.</li> </ol>
<b>Yellow "Alert"</b> <b>Flash Code 3</b>	<b>Short Cycling</b> Compressor is running only briefly	<ol style="list-style-type: none"> <li>1 Thermostat demand signal is intermittent.</li> <li>2 Time delay relay or control board is defective.</li> <li>3 If high pressure switch is present, check Flash Code 2 information.</li> <li>4 If low pressure switch is present, check Flash Code 1 information.</li> </ol>
<b>Yellow "Alert"</b> <b>Flash Code 4</b>	<b>Locked Rotor</b>	<ol style="list-style-type: none"> <li>1 Run capacitor has failed.</li> <li>2 Low line voltage (contact utility if voltage at disconnect is low).</li> <li>3 Excessive liquid refrigerant in the compressor.</li> <li>4 Compressor bearings are seized.</li> </ol>
<b>Yellow "Alert"</b> <b>Flash Code 5</b>	<b>Open Circuit</b>	<ol style="list-style-type: none"> <li>1 Outdoor unit power disconnect is open.</li> <li>2 Unit circuit breaker or fuse(s) is open.</li> <li>3 Unit contactor has failed to close.</li> <li>4 High pressure switch is open and requires manual reset.</li> <li>5 Open circuit in compressor supply wiring or connections.</li> <li>6 Unusually long compressor protector reset time due to extreme ambient temperature.</li> <li>7 Compressor windings are damaged.</li> </ol>
<b>Yellow "Alert"</b> <b>Flash Code 6</b>	<b>Open Start Circuit</b> Current only in run circuit	<ol style="list-style-type: none"> <li>1 Run capacitor has failed.</li> <li>2 Open circuit in compressor start wiring or connections.</li> <li>3 Compressor start winding is damaged.</li> </ol>
<b>Yellow "Alert"</b> <b>Flash Code 7</b>	<b>Open Run Circuit</b> Current only in start circuit	<ol style="list-style-type: none"> <li>1 Open circuit in compressor start wiring or connections.</li> <li>2 Compressor start winding is damaged.</li> </ol>
<b>Yellow "Alert"</b> <b>Flash Code 8</b>	<b>Welded Contactor</b> Compressor always runs	<ol style="list-style-type: none"> <li>1 Compressor contactor failed to open.</li> <li>2 Thermostat demand signal not connected to module.</li> </ol>
<b>Yellow "Alert"</b> <b>Flash Code 9</b>	<b>Low Voltage</b> Control circuit < 17VAC	<ol style="list-style-type: none"> <li>1 Control circuit transformer is overloaded</li> <li>2 Low line voltage (contact utility if voltage at disconnect is low).</li> </ol>

- Flash code number corresponds to a number of LED flashes, followed by a pause, and then repeated.
- TRIP and ALERT LEDs flashing at the same time indicates that the control circuit voltage is too low for operation.
- Reset ALERT flash code by removing 24VAC power from monitor. Last ALERT flash code will display for 1 minute after monitor is powered on.

### E-TOC Timed Off Control (HSXA15-1 Units Only)

HSXA15-1 units are equipped with a TOC, (timed off control). The TOC is located in the control box (figure 5). The TOC is electrically connected between thermostat terminal Y and the compressor contactor. When thermostat demand is satisfied, the TOC opens the circuit to the compressor contactor coil and the compressor is de-energized. Between cycles, the compressor contactor is delayed for 5 minutes + 2 minutes. At the end of the delay, the compressor is allowed to energize. Without the time delay it would be possible to short cycle the compressor.

### F-Dual Capacitor (C12)

The compressor and fan in all units use permanent split capacitor motors. A single “dual” capacitor is used for both the fan motor and the compressor (see unit wiring diagram). The two sides (fan and compressor) of the capacitor have different mfd ratings and may change with each compressor. The capacitor is located inside the unit control box.

### G-Contactor (K1)

The compressor is energized by a contactor located in the control box. All units are single-phase with single-pole contactors. See figure 5 for location.

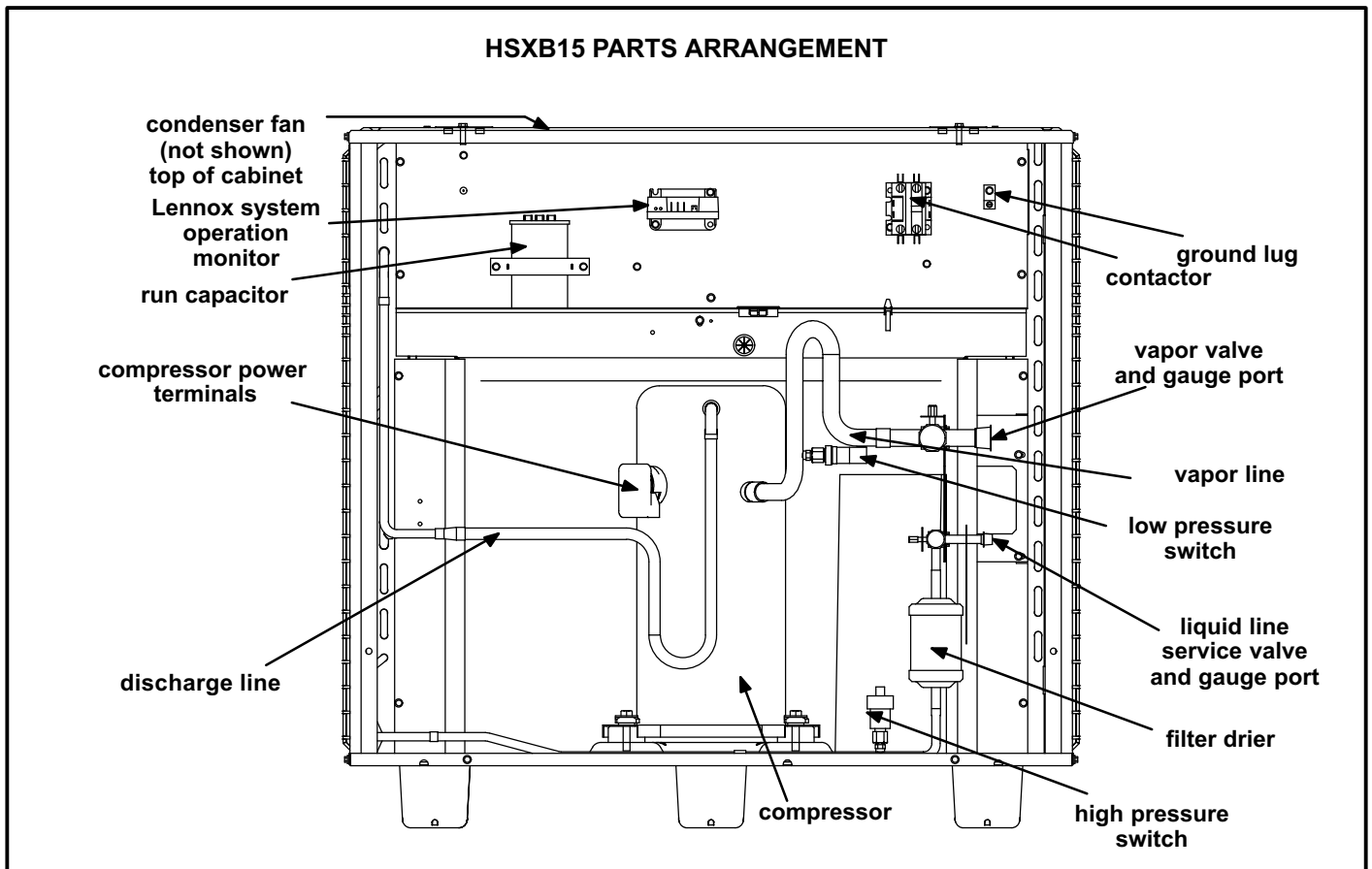

FIGURE 5

## H-Filter Drier

A filter drier designed for all HSXA15 model units is factory supplied and must be installed in the liquid line. The filter drier for the HSXB15 units is factory installed in the liquid line. The filter drier is designed to remove moisture and foreign matter, which can lead to compressor failure.

### Moisture and / or Acid Check

Because POE oils absorb moisture, the dryness of the system must be verified any time the refrigerant system is exposed to open air. A compressor oil sample must be taken to determine if excessive moisture has been introduced to the oil. Table 2 lists kits available from Lennox to check POE oils.

If oil sample taken from a system that has been exposed to open air does not test in the dry color range, the filter drier MUST be replaced.

## **⚠ IMPORTANT**

**Replacement filter drier MUST be approved for R410A refrigerant and POE application.**

### Foreign Matter Check

It is recommended that a liquid line filter drier be replaced when the pressure drop across the filter drier is greater than 3 psig.

**TABLE 2**

KIT	CONTENTS	TUBE SHELF LIFE
10N46 - Refrigerant Analysis	Checkmate-RT700	
10N45 - Acid Test Tubes	Checkmate-RT750A (three pack)	2 - 3 years @ room temperature. 3+ years refrigerated
10N44 - Moisture Test Tubes	Checkmate - RT751 Tubes (three pack)	6 - 12 months @ room temperature. 2 years refrigerated
74N40 - Easy Oil Test Tubes	Checkmate - RT752C Tubes (three pack)	2 - 3 years @ room temperature. 3+ years refrigerated
74N39 - Acid Test Kit	Sporlan One Shot - TA-1	

### MEASURING FILTER DRIER PRESSURE DROP

- 1- Shut off power to unit.
- 2- Remove high pressure switch from fitting next to filter drier. (A schrader core is located under the high pressure switch).
- 3- Install high pressure gauge hose onto high pressure switch fitting.
- 4- Turn power on to unit and turn room thermostat to call for cooling.
- 5- Record pressure reading on gauge.
- 6- Remove hose from high pressure fitting and install on liquid line valve.
- 7- Read liquid line valve pressure.
- 8- High pressure fitting pressure - liquid line valve pressure = filter drier pressure drop.
- 9- If pressure drop is greater than 4 psig replace filter drier. See figure 7.
- 10- Re-install high pressure switch.

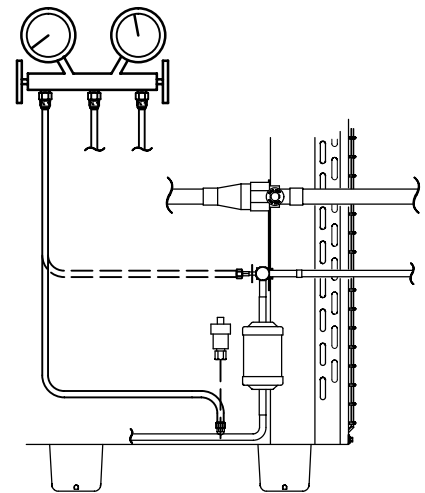

**FIGURE 6**

### REPLACING FILTER DRIER

- 1- Recover all refrigerant from unit.
- 2- Remove original filter drier.
- 3- Install new filter drier in existing location or alternate location as shown. *Proper brazing procedures should be followed.*
- 4- Evacuate system. See section IV- part B-.
- 5- Recharge system. See section IV- part C-.

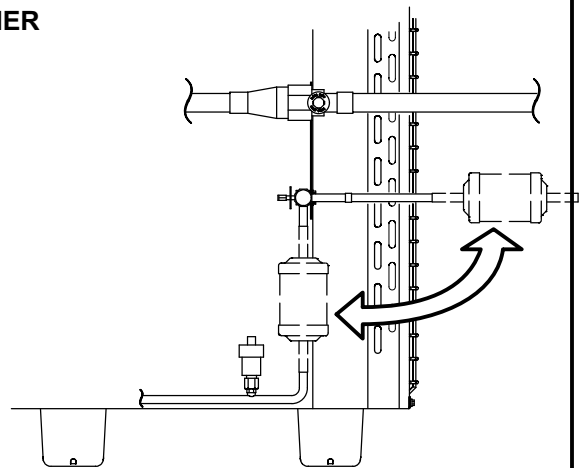

**FIGURE 7**



## I-Condenser Fan Motor (B4)

All units use single-phase PSC fan motors which require a run capacitor. The "FAN" side of the dual capacitor is used for this purpose. The specifications tables on page 1 and 2 of this manual show the specifications of outdoor fans used in HSXA15 units. In all units, the outdoor fan is controlled by the compressor contactor. See figure 8 if condenser fan motor replacement is necessary.

### ⚠ IMPORTANT

Route fan motor leads away from fan blades when replacing fan motor. Use wire drip loop as shown in figure 8.

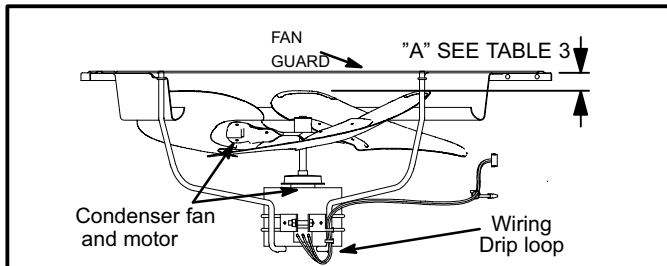

**FIGURE 8**  
**TABLE 3**

HSXA/B15 UNIT	"A" DIM. ± 1/8"
-024	1 1/4"
-030	2"
-036, -042	1 1/2"
-048	2 1/16"
-060	2 1/16"

## III-REFRIGERANT SYSTEM

### A-Plumbing

Field refrigerant piping consists of liquid and suction lines from the outdoor unit (sweat connections). Use Lennox L15 series line sets as shown in table 4 or field-fabricated refrigerant lines.

Separate discharge and suction service ports are provided at the compressor for connection of gauge manifold during charging procedure.

**TABLE 4**

Model No.	Valve Field Size Connections		Recommended Line Set		
	Liquid Line	Vapor Line	Liquid Line	Vapor Line	L15 Line Sets
-024 -030 -036	3/8 in. (10 mm)	3/4 in. (19 mm)	3/8 in. (10 mm)	3/4 in. (19 mm)	L15-41 15 ft. - 50 ft. (4.6 m - 15 m)
-042 -048	3/8 in. (10 mm)	7/8 in. (22 mm)	3/8 in. (10 mm)	7/8 in. (22 mm)	L15-65 15 ft. - 50 ft. (4.6 m - 15 m)
-060	3/8 in. (10 mm)	1-1/8 in. (29 mm)	3/8 in. (10 mm)	1-1/8 in. (29 mm)	Field Fabricated

## B-Service Valves

The liquid line and vapor line service valves and gauge ports are accessible by removing the compressor access cover. Full service liquid and vapor line valves are used. See figures 9 and 10. The service ports are used for leak testing, evacuating, charging and checking charge. Service valves have a factory-installed schrader valve. A service port cap is supplied to protect the schrader valve from contamination and assure a leak free seal. Valves are not rebuildable. If a valve has failed it must be replaced. The pressure tap fitting has a LIGHT MAROON tag to remind service technicians that the unit contains R410A.

See table 5 for service valve torque requirements.

**Table 5**  
**Torque Requirements**

Part	Recommended Torque	
Service valve cap	8 ft.- lb.	11 NM
Sheet metal screws	16 in.- lb.	2 NM
Machine screws #10	28 in.- lb.	3 NM
Compressor bolts	90 in.- lb.	10 NM
Gauge port seal cap	8 ft.- lb.	11 NM

### To Access Schrader Port:

- 1 - Remove service port cap with an adjustable wrench.
- 2 - Connect gauge to the service port.
- 3 - When testing is complete, replace service port cap. Tighten finger tight, then an additional 1/6 turn.

### To Open Service Valve:

- 1 - Remove the stem cap with an adjustable wrench.
- 2 - Use a service wrench with a hex-head extension to back the stem out counterclockwise as far as it will go.  
*NOTE - Use a 3/16" hex head extension for liquid line sizes or a 5/16" extension for vapor line sizes.*
- 3 - Replace the stem cap. Tighten finger tight, then tighten an additional 1/6 turn.

### To Close Service Valve:

- 1 - Remove the stem cap with an adjustable wrench.
- 2 - Use a service wrench with a hex-head extension to turn the stem clockwise to seat the valve. Tighten the stem firmly.  
*NOTE - Use a 3/16" hex head extension for liquid line sizes or a 5/16" extension for vapor line sizes.*
- 3 - Replace the stem cap. Tighten finger tight, then tighten an additional 1/6 turn.

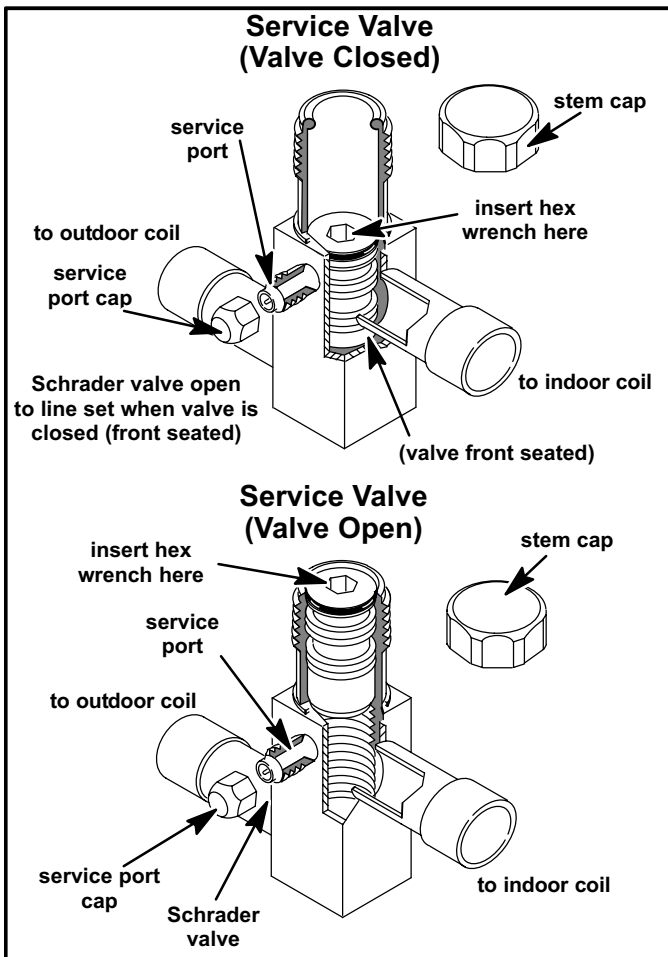

FIGURE 9

### Vapor Line Ball Valve 5 ton Only

Vapor line ball valves function the same way as the other valves, the difference is in the construction. These valves are not rebuildable. If a valve has failed, you must replace it. A ball valve is illustrated in figure 10.

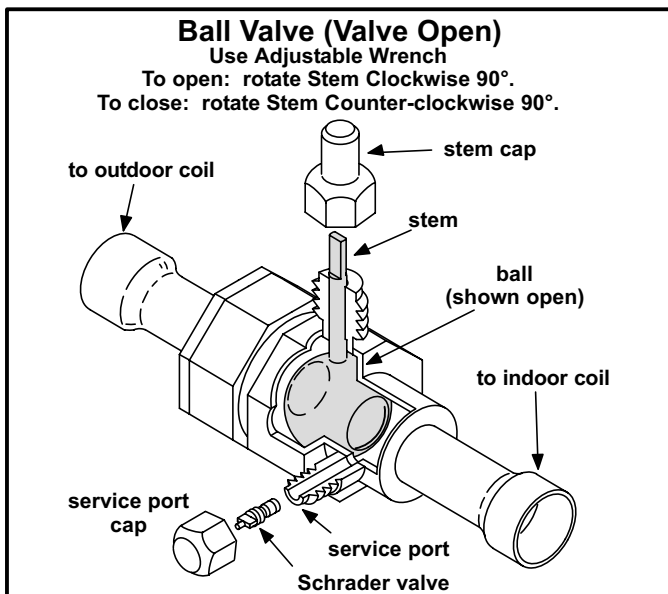

FIGURE 10

## IV-CHARGING

Units are factory charged with the amount of R410A refrigerant indicated on the unit rating plate. This charge is based on a matching indoor coil and outdoor coil with 15 ft. (4.5m) line set. For varying lengths of line set, refer to table 6 for refrigerant charge adjustment.

TABLE 6

Liquid Line Set Diameter	Ozs. per 5 ft. (grams per 1.5m) adjust from 15 ft. (4.5m) line set*
3/8 in. (10mm)	3 ounces per 5 feet (85g per 1.5m)

\*If line length is greater than 15 ft. (4.5 m), add this amount. If line length is less than 15 ft. (4.5m), subtract this amount.

### A-Leak Testing

After the line set has been connected to the indoor and outdoor units, check the line set connections and indoor unit for leaks.

### ⚠ WARNING

Refrigerant can be harmful if it is inhaled. Refrigerant must be used and recovered responsibly.

Failure to follow this warning may result in personal injury or death.

### ⚠ WARNING



Danger of explosion: Can cause equipment damage, injury or death. Never use oxygen to pressurize a refrigeration or air conditioning system. Oxygen will explode on contact with oil and could cause personal injury.

### ⚠ WARNING

Danger of explosion: Can cause equipment damage, injury or death. When using a high pressure gas such as dry nitrogen to pressurize a refrigeration or air conditioning system, use a regulator that can control the pressure down to 1 or 2 psig (6.9 to 13.8 kPa).

### Using an Electronic Leak Detector or Halide

- 1 - Connect a cylinder of R410A to the center port of the manifold gauge set.
- 2 - With both manifold valves closed, open the valve on the R410A cylinder (vapor only).
- 3 - Open the high pressure side of the manifold to allow the R410A into the line set and indoor unit. Weigh in a trace amount of R410A. [A trace amount is a maximum of 2 ounces (57 g) or 3 pounds (31 kPa) pressure.] Close the valve on the R410A cylinder and the valve on the high pressure side of the manifold gauge set. Disconnect the R410A cylinder.
- 4 - Connect a cylinder of nitrogen with a pressure regulating valve to the center port of the manifold gauge set.

- 5 - Connect the manifold gauge set high pressure hose to the vapor valve service port. (Normally, the high pressure hose is connected to the liquid line port; however, connecting it to the vapor port better protects the manifold gauge set from high pressure damage.)
- 6 - Adjust the nitrogen pressure to 150 psig (1034 kPa). Open the valve on the high side of the manifold gauge set which will pressurize line set and indoor unit.
- 7 - After a few minutes, open a refrigerant port to ensure the refrigerant you added is adequate to be detected. (Amounts of refrigerant will vary with line lengths.) Check all joints for leaks. Purge nitrogen and R410A mixture. Correct any leaks and recheck.

## B-Evacuating the System

Evacuating the system of noncondensables is critical for proper operation of the unit. Noncondensables are defined as any gas that will not condense under temperatures and pressures present during operation of an air conditioning system. Noncondensables and water vapor combine with refrigerant to produce substances that corrode copper piping and compressor parts.

### IMPORTANT

**Use a thermocouple or thermistor electronic vacuum gauge that is calibrated in microns. Use an instrument that reads from 50 microns to at least 10,000 microns.**

- 1 - Connect manifold gauge set to the service valve ports :
  - low pressure gauge to *vapor* line service valve
  - high pressure gauge to *liquid* line service valve
- 2 - Connect micron gauge.
- 3 - Connect the vacuum pump (with vacuum gauge) to the center port of the manifold gauge set.
- 4 - Open both manifold valves and start the vacuum pump.
- 5 - Evacuate the line set and indoor unit to an **absolute pressure** of 23,000 microns (29.01 inches of mercury). During the early stages of evacuation, it is desirable to close the manifold gauge valve at least once to determine if there is a rapid rise in **absolute pressure**. A rapid rise in pressure indicates a relatively large leak. If this occurs, repeat the leak testing procedure.

*NOTE - The term **absolute pressure** means the total actual pressure within a given volume or system, above the absolute zero of pressure. Absolute pressure in a vacuum is equal to atmospheric pressure minus vacuum pressure.*

- 6 - When the absolute pressure reaches 23,000 microns (29.01 inches of mercury), close the manifold gauge valves, turn off the vacuum pump and disconnect the manifold gauge center port hose from vacuum pump. Attach the manifold center port hose to a nitrogen cylinder with pressure regulator set to 150 psig (1034 kPa) and purge the hose. Open the manifold gauge valves to break the vacuum in the line set and indoor unit. Close the manifold gauge valves.

### CAUTION

**Danger of Equipment Damage.**

**Avoid deep vacuum operation. Do not use compressors to evacuate a system.**

**Extremely low vacuums can cause internal arcing and compressor failure.**

**Damage caused by deep vacuum operation will void warranty.**

- 7 - Shut off the nitrogen cylinder and remove the manifold gauge hose from the cylinder. Open the manifold gauge valves to release the nitrogen from the line set and indoor unit.
- 8 - Reconnect the manifold gauge to the vacuum pump, turn the pump on, and continue to evacuate the line set and indoor unit until the absolute pressure does not rise above 500 microns (29.9 inches of mercury) within a 20-minute period after shutting off the vacuum pump and closing the manifold gauge valves.
- 9 - When the absolute pressure requirement above has been met, disconnect the manifold hose from the vacuum pump and connect it to an upright cylinder of R410A refrigerant. Open the manifold gauge valves to break the vacuum from 1 to 2 psig positive pressure in the line set and indoor unit. Close manifold gauge valves and shut off the R410A cylinder and remove the manifold gauge set.

## C-Charging

### **⚠ IMPORTANT**

**Mineral oils are not compatible with R410A. If oil must be added, it must be a polyol ester oil.**

The compressor is charged with sufficient polyol ester oil for line set lengths up to 50 ft.

#### **Weighing in the Charge Fixed Orifice or TXV Systems – Outdoor Temp < 65°F (18°C)**

If the system is void of refrigerant, or if the outdoor ambient temperature is cool, the refrigerant charge should be weighed into the unit. Do this after any leaks have been repaired.

- 1 - Recover the refrigerant from the unit.
- 2 - Conduct a leak check, then evacuate as previously outlined.
- 3 - Weigh in the unit nameplate charge.

If weighing facilities are not available or if you are charging the unit during warm weather, follow one of the other procedures outlined below.

#### **Approach and Normal Operating Pressures TXV Systems – Outdoor Temp. ≥ 65°F (18°C)**

The following procedure is intended as a general guide and is for use on expansion valve systems only. For best results, indoor temperature should be 70°F (21°C) to 80°F (26°C). Monitor system pressures while charging.

- 1 - Record outdoor ambient temperature using a digital thermometer.
- 2 - Attach high pressure gauge set and operate unit for several minutes to allow system pressures to stabilize.
- 3 - Compare stabilized pressures with those provided in table 8, "Normal Operating Pressures." Minor variations in these pressures may be expected due to differences in installations. Significant differences could mean that the system is not properly charged or that a problem exists with some component in the system. Pressures higher than those listed indicate that the system is overcharged. Pressures lower than those listed indicate that the system is undercharged. Verify adjusted charge using the approach method.
- 4 - Outdoor temperature should be 65°F (18°C) or above. Use the same digital thermometer used to check outdoor ambient temperature to check liquid line temperature. Verify the unit charge using the approach method. The difference between the ambient and liquid temperatures should match values given in table 3. Refrigerant must be added to lower approach temperature and removed to increase approach temperature. Loss of charge results in low capacity and efficiency.

- 5 - If the values don't agree with the those in table 7, add refrigerant to lower the approach temperature or recover refrigerant from the system to increase the approach temperature.

**TABLE 7  
APPROACH TEMPERATURES**

HSXA/B15 Unit	Approach Temperature Liquid Line Temp. - Outdoor Ambient °F
-024	8 ± 1
-030	8 ± 1
-036	6 ± 1
-042	9 ± 1
-048	8 ± 1
-060	12 ± 1

*NOTE - For best results, the same electronic thermometer should be used to check both outdoor ambient and liquid line temperatures.*

### **⚠ IMPORTANT**

**REFRIGERANT SHOULD BE ADDED THROUGH THE SUCTION VALVE IN THE LIQUID STATE.**

## D-Oil Charge

Refer to compressor nameplate.

## V-SERVICE AND RECOVERY

### **⚠ WARNING**

**Polyol ester (POE) oils used with R410A refrigerant absorb moisture very quickly. It is very important that the refrigerant system be kept closed as much as possible. DO NOT remove line set caps or service valve stub caps until you are ready to make connections.**

### **⚠ IMPORTANT**

**USE RECOVERY MACHINE RATED FOR R410A REFRIGERANT.**

If the system must be opened for any kind of service, such as compressor or filter drier replacement, you must take extra precautions to prevent moisture from entering the system. The following steps will help to minimize the amount of moisture that enters the system during recovery of R410A.

- 1 - Use a regulator-equipped nitrogen cylinder to break the system vacuum. Do not exceed 5 psi. The dry nitrogen will fill the system, purging any moisture.
- 2 - Remove the faulty component and quickly seal the system (using tape or some other means) to prevent additional moisture from entering the system.
- 3 - Do not remove the tape until you are ready to install new component. Quickly install the replacement component.
- 4 - Evacuate the system to remove any moisture and other non-condensables.

The HSXA15 and HSXB15 system **MUST** be checked for moisture anytime the sealed system is opened.

Any moisture not absorbed by the polyol ester oil can be removed by triple evacuation. Moisture that has been absorbed by the compressor oil can be removed by replacing the drier.

## **IMPORTANT**

**Evacuation of system only will not remove moisture from oil. Drier must be replaced to eliminate moisture from POE oil.**

## VI-MAINTENANCE

## **WARNING**



**Electric shock hazard. Can cause injury or death. Before attempting to perform any service or maintenance, turn the electrical power to unit OFF at disconnect switch(es). Unit may have multiple power supplies.**

Maintenance and service must be performed by a qualified installer or service agency. At the beginning of each cooling season, the system should be checked as follows:

- 1 - Clean and inspect the outdoor coil. The coil may be flushed with a water hose. Ensure the power is turned off before you clean the coil.
- 2 - Condenser fan motor is prelubricated and sealed. No further lubrication is needed.
- 3 - Visually inspect connecting lines and coils for evidence of oil leaks.
- 4 - Check wiring for loose connections.
- 5 - Check for correct voltage at unit (unit operating).
- 6 - Check amp-draw condenser fan motor.

*NOTE - If owner complains of insufficient cooling, the unit should be gauged and refrigerant charge checked. Refer to section on refrigerant charging in this instruction.*

### **Indoor Coil**

- 1 - Clean coil, if necessary.
- 2 - Check connecting lines and coils for evidence of oil leaks.
- 3 - Check the condensate line and clean it if necessary.

### **Indoor Unit**

- 1 - Clean or change filters.
- 2 - Adjust blower speed for cooling. Measure the pressure drop over the coil to determine the correct blower CFM. Refer to the unit information service manual for pressure drop tables and procedure.
- 3 - *Belt Drive Blowers* - Check belt for wear and proper tension.
- 4 - Check all wiring for loose connections
- 5 - Check for correct voltage at unit (blower operating).
- 6 - Check amp-draw on blower motor and compressor.

### **Compressor Replacement**

Standard procedures can be followed when replacing the compressor in the -030 through -060 models. However, the compressor has minimal clearances in the -024. If compressor replacement is necessary, it may be helpful to raise the filler panel allowing adequate space for compressor movement. Follow the steps below using a 5/16" driver.

- 1- Remove access panel.
- 2- Remove lower screw in the left side of the control box and the screw located directly below it in the filler panel.
- 3- Panels can now be adjusted to remove compressor.
- 4- Re-install screws after compressor has been replaced.  
*NOTE - removing condenser fan grill and reaching in from back side may help re-align panels to original position.*

**TABLE 8  
NORMAL OPERATING PRESSURES  
(Liquid ±10 and Suction ±5 psig)**

MODE	OUTDOOR COIL ENTERING AIR TEMP. °F (°C)	HSXA15 -024-1, -2		HSXB15 -024		HSXA15 HSXB15 -030		HSXA15 HSXB15 -036		HSXA15 HSXB15 -042		HSXA15 HSXB15 -048		HSXA15 HSXB15 -060	
		LIQ	VAP	LIQ	VAP	LIQ	VAP	LIQ	VAP	LIQ	VAP	LIQ	VAP	LIQ	VAP
TXV	65 (18.3)	239	129	253	132	232	130	235	128	241	131	226	130	240	130
	75 (23.9)	278	131	288	135	271	132	276	130	282	133	266	132	279	132
	85 (29.4)	321	133	330	137	314	135	320	132	326	135	310	135	321	135
	95 (35.0)	368	135	376	140	360	137	367	134	373	137	356	137	368	137
	105 (40.6)	420	138	425	143	412	140	421	137	424	139	407	139	418	140

**TABLE 9  
R410A Temperature/Pressure Chart**

Temperature °F	Pressure Psig	Temperature °F	Pressure Psig	Temperature °F	Pressure Psig	Temperature °F	Pressure Psig
32	100.8	63	178.5	94	290.8	125	445.9
33	102.9	64	181.6	95	295.1	126	451.8
34	105.0	65	184.3	96	299.4	127	457.6
35	107.1	66	187.7	97	303.8	128	463.5
36	109.2	67	190.9	98	308.2	129	469.5
37	111.4	68	194.1	99	312.7	130	475.6
38	113.6	69	197.3	100	317.2	131	481.6
39	115.8	70	200.6	101	321.8	132	487.8
40	118.0	71	203.9	102	326.4	133	494.0
41	120.3	72	207.2	103	331.0	134	500.2
42	122.6	73	210.6	104	335.7	135	506.5
43	125.0	74	214.0	105	340.5	136	512.9
44	127.3	75	217.4	106	345.3	137	519.3
45	129.7	76	220.9	107	350.1	138	525.8
46	132.2	77	224.4	108	355.0	139	532.4
47	134.6	78	228.0	109	360.0	140	539.0
48	137.1	79	231.6	110	365.0	141	545.6
49	139.6	80	235.3	111	370.0	142	552.3
50	142.2	81	239.0	112	375.1	143	559.1
51	144.8	82	242.7	113	380.2	144	565.9
52	147.4	83	246.5	114	385.4	145	572.8
53	150.1	84	250.3	115	390.7	146	579.8
54	152.8	85	254.1	116	396.0	147	586.8
55	155.5	86	258.0	117	401.3	148	593.8
56	158.2	87	262.0	118	406.7	149	601.0
57	161.0	88	266.0	119	412.2	150	608.1
58	163.9	89	270.0	120	417.7	151	615.4
59	166.7	90	274.1	121	423.2	152	622.7
60	169.6	91	278.2	122	428.8	153	630.1
61	172.6	92	282.3	123	434.5	154	637.5
62	195.5	93	286.5	124	440.2	155	645.0

**VII-DIAGRAMS / OPERATING SEQUENCE**  
**A- Unit Diagram HSXA15-024/060-2P**

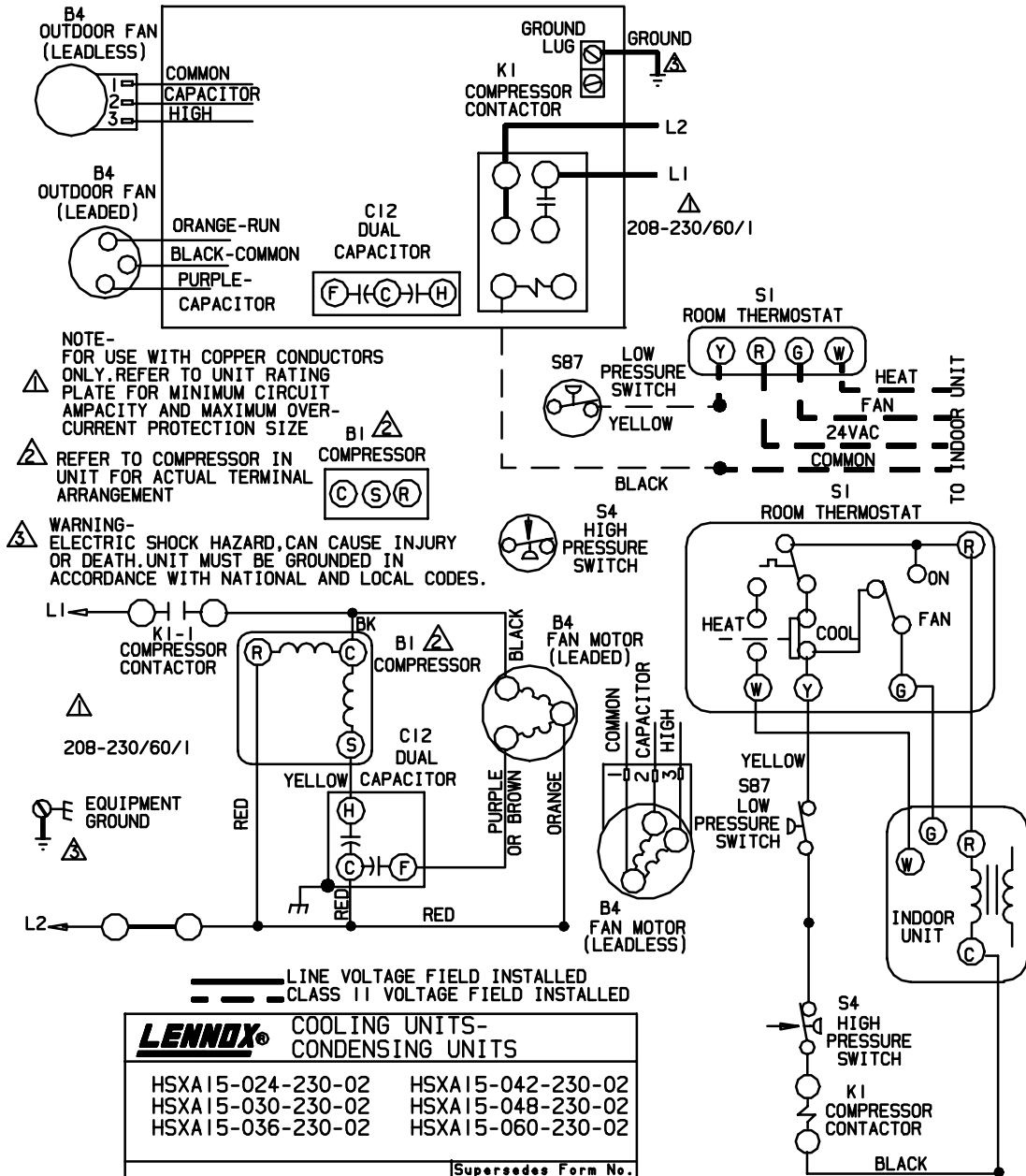

**Operation Sequence**

- 1 - Cooling demand energizes thermostat terminal Y. Voltage from terminal Y passes through the low pressure switch, (the timed-off control on -1 units), the high pressure switch and energizes the K1 compressor contactor coil (provided 5-minute delay is satisfied).
- 2 - K1 closes energizing B1 compressor and B4 outdoor fan.
- 3 - When cooling demand is satisfied, K1 opens and de-energizes the compressor and outdoor fan. (The timed off control begins a 5-minute delay on -1 units only).

# B- Unit Diagram HSXB15-024/060-1P

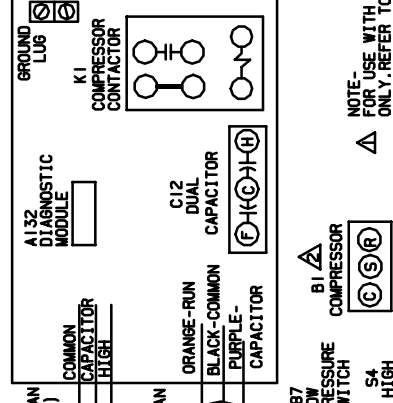
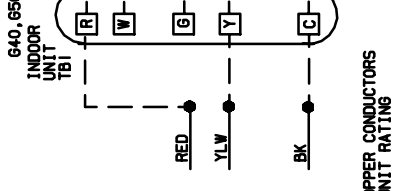
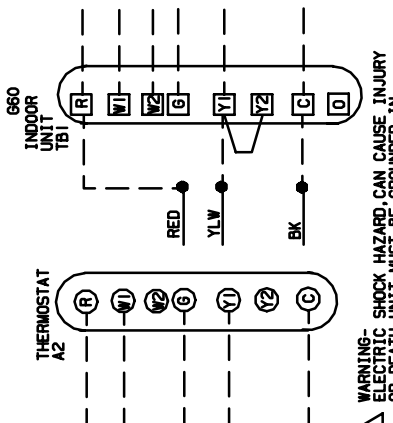
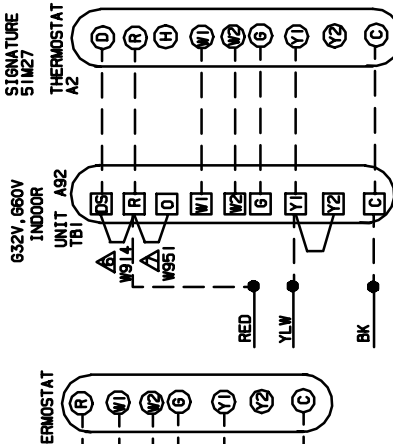
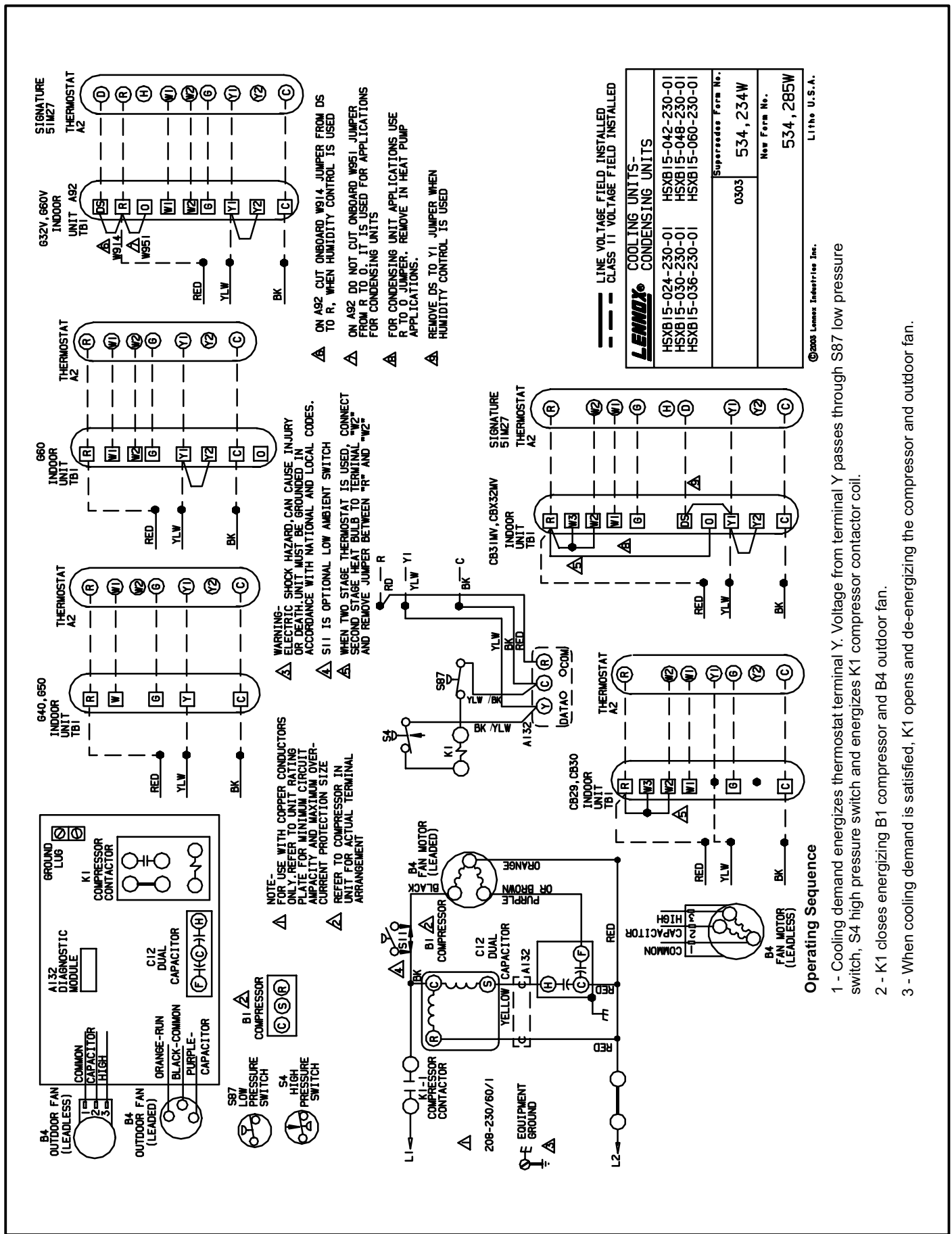

NOTE -  
FOR USE WITH COPPER CONDUCTORS  
ONLY. REFER TO UNIT RATING  
PLATE FOR MINIMUM CIRCUIT  
CAPACITY AND MAXIMUM OVER-  
CURRENT PROTECTION SIZE.  
REFER TO COMPRESSOR IN  
UNIT FOR ACTUAL TERMINAL  
ARRANGEMENT.

WARNING -  
ELECTRIC SHOCK HAZARD CAN CAUSE INJURY  
OR DEATH. UNIT MUST BE GROUNDED IN  
ACCORDANCE WITH NATIONAL AND LOCAL CODES.  
S11 IS OPTIONAL LOW AMBIENT SWITCH  
WHEN TWO STAGE THERMOSTAT IS USED, CONNECT  
SECOND STAGE HEAT BULB TO TERMINAL "W2"  
AND REMOVE JUMPER BETWEEN "R" AND "W2"

ON A92, CUT ONBOARD W914 JUMPER FROM DS  
TO R, WHEN HUMIDITY CONTROL IS USED

ON A92 DO NOT CUT ONBOARD W951 JUMPER  
FROM R TO O. IT IS USED FOR APPLICATIONS  
FOR CONDENSING UNITS

FOR CONDENSING UNIT APPLICATIONS USE  
R TO O JUMPER. REMOVE IN HEAT PUMP  
APPLICATIONS.

REMOVE DS TO Y1 JUMPER WHEN  
HUMIDITY CONTROL IS USED

WARNING -  
ELECTRIC SHOCK HAZARD CAN CAUSE INJURY  
OR DEATH. UNIT MUST BE GROUNDED IN  
ACCORDANCE WITH NATIONAL AND LOCAL CODES.  
S11 IS OPTIONAL LOW AMBIENT SWITCH  
WHEN TWO STAGE THERMOSTAT IS USED, CONNECT  
SECOND STAGE HEAT BULB TO TERMINAL "W2"  
AND REMOVE JUMPER BETWEEN "R" AND "W2"

WARNING -  
ELECTRIC SHOCK HAZARD CAN CAUSE INJURY  
OR DEATH. UNIT MUST BE GROUNDED IN  
ACCORDANCE WITH NATIONAL AND LOCAL CODES.  
S11 IS OPTIONAL LOW AMBIENT SWITCH  
WHEN TWO STAGE THERMOSTAT IS USED, CONNECT  
SECOND STAGE HEAT BULB TO TERMINAL "W2"  
AND REMOVE JUMPER BETWEEN "R" AND "W2"

WARNING -  
ELECTRIC SHOCK HAZARD CAN CAUSE INJURY  
OR DEATH. UNIT MUST BE GROUNDED IN  
ACCORDANCE WITH NATIONAL AND LOCAL CODES.  
S11 IS OPTIONAL LOW AMBIENT SWITCH  
WHEN TWO STAGE THERMOSTAT IS USED, CONNECT  
SECOND STAGE HEAT BULB TO TERMINAL "W2"  
AND REMOVE JUMPER BETWEEN "R" AND "W2"

--- LINE VOLTAGE FIELD INSTALLED  
- - - CLASS 11 VOLTAGE FIELD INSTALLED

LENOX® COOLING UNITS - CONDENSING UNITS	
HSXB15-024-230-01	HSXB15-042-230-01
HSXB15-030-230-01	HSXB15-048-230-01
HSXB15-036-230-01	HSXB15-060-230-01
Superceder Form No.	534, 234W
	New Form No.
	534, 285W

©2003 Lennox Industries Inc. Litho U.S.A.

### Operating Sequence

- 1 - Cooling demand energizes thermostat terminal Y. Voltage from terminal Y passes through S87 low pressure switch, S4 high pressure switch and energizes K1 compressor contactor coil.
- 2 - K1 closes energizing B1 compressor and B4 outdoor fan.
- 3 - When cooling demand is satisfied, K1 opens and de-energizing the compressor and outdoor fan.