

G20RE SERIES UNITS

I - INTRODUCTION

G20RE and G20RXE series units are mid-efficiency downflow gas furnaces with Duracurve™ heat exchangers formed of aluminized steel. G20RE units come in heating capacities of 50,000 to 150,000 Btuh. In cooling applications, blowers are equipped to handle up to 5 tons of cooling capacity. Refer to Engineering Handbook for proper sizing.

Units are factory supplied for use with natural gas. A conversion kit to LPG operation is available for the G20RE only. All units are equipped with an electronic ignition. G20RXE models meet the California Nitrogen Oxides (NO_x) Standards and California Seasonal Efficiency requirements. All units use a redundant gas valve to assure safety shut-off as required by A.G.A.

Featured on G20RE series is a burner box damper assembly located on the intake side of the burners. A damper door in the burner box shuts during unit off cycles to retain heat in the unit. A damper prove switch ensures that damper is open before gas valve is energized. Since the G20RE furnaces have atmospheric burners there is no induced draft motor. All G20RE units have a draft diverter which allows the use of standard single wall vent connectors.

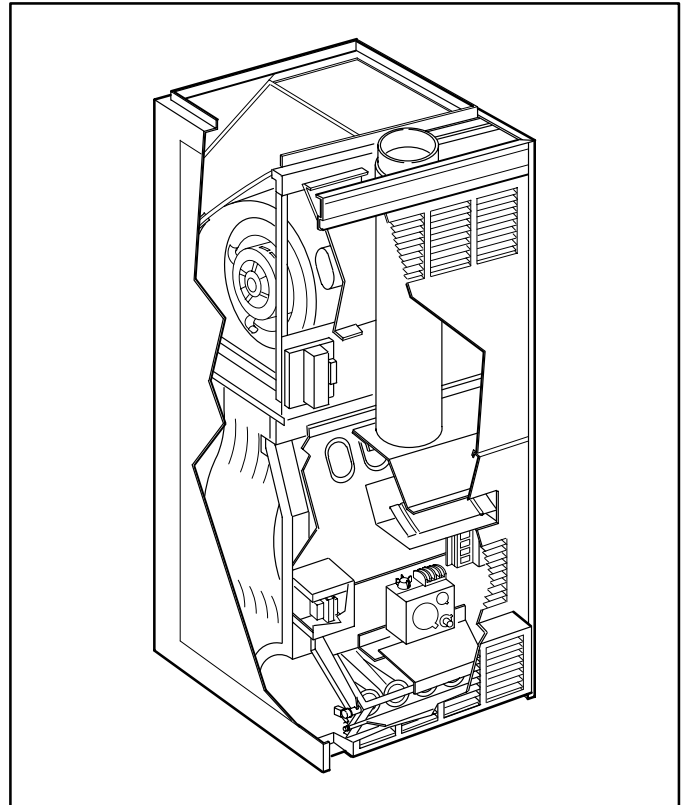

SPECIFICATIONS (continued on next page)

Model No.	G20RQ2/3E-50 •G20RQ2/3XE-50	G20RQ3E-75 •G20RQ3XE-75	G20RQ4E-75 •G20RQ4XE-75	G20RQ3/4E-100 •G20RQ3/4XE-100
Input Btuh	50,000	75,000	75,000	100,000
Output Btuh	40,000	58,000	59,000	79,000
*A.F.U.E.	78.0%	78.0%	78.0%	78.0%
California Seasonal Efficiency- "X" Models	72.1%	74.8%	72.0%	74.5%
Flue connection (in. diameter)	4 Round	4 Round	4 Round	5 Oval
Temperature rise range	20-50	50-80	30-60	50-80
High static certified by A.G.A.(in wg.)	.50	.50	.50	.50
Gas piping size	Natural	1/2	1/2	1/2
I.P.S. (in.)	**LPG	1/2	1/2	1/2
Blower wheel nominal diameter x width (in.)	10 x 8	10 x 8	11 x 9	11 x 9
Blower motor hp.	1/3	1/3	1/2	1/2
Number and Size of Filters (in.)	(2) 20 x 10 x 1	(2) 20 x 10 x 1	(2) 20 x 12 x 1	(2) 20 x 12 x 1
Tons of cooling (add-on)	2, 2-1/2 or 3	2, 2-1/2 or 3	3, 3-1/2 or 4	3, 3-1/2 or 4
Electrical characteristics	120 volts — 60 hertz — 1 phase (less than 12 amps) — All Models			

*Annual Fuel Utilization Efficiency based on D.O.E. test procedures and according to F.T.C. labeling requirements.

Isolated combustion system rating for non-weatherized furnaces.

**LPG kit must be ordered extra for field changeover.

•Not Available with LPG.

SPECIFICATIONS (continued from previous page)

Model No.	G20RQ5E-100 •G20RQ5XE-100	G20RQ3E-125 •G20RQ3XE-125	G20RQ4/5E-125 •G20RQ4/5XE-125	G20RQ4/5E-150
Input Btuh	100,000	125,000	125,000	150,000
Output Btuh	77,000	98,000	99,000	118,000
*A.F.U.E.	78.0%	78.0%	78.0%	78.0%
California Seasonal Efficiency- "X" Models	74.7%	75.6%	74.4%	—
Flue connection (in. diameter)	5 Oval	5 Oval	5 Oval	6 Oval
Temperature rise range	40-70	70-100	50-80	55-85
High static certified by A.G.A.(in wg.)	.50	.50	.50	.50
Gas piping size I.P.S. (in.)	Natural	1/2	1/2	1/2
	**LPG	1/2	1/2	1/2
Blower wheel nominal diameter x width (in.)	12 x 12	10 x 8	12 x 12	12 x 12
Blower motor hp.	3/4	1/3	3/4	3/4
Number and Size of Filters (in.)	(2) 20 x 14 x 1	(2) 20 x 14 x 1	(2) 20 x 14 x 1	(2) 20 x 16 x 1
Tons of cooling (add-on)	4, 4-1/2 or 5	2, 2-1/2 or 3	4, 4-1/2 or 5	4, 4-1/2 or 5
Electrical characteristics	120 volts — 60 hertz — 1 phase (less than 12 amps) — All Models			

*Annual Fuel Utilization Efficiency based on D.O.E. test procedures and according to F.T.C. labeling requirements.
 Isolated combustion system rating for non-weatherized furnaces.

**LPG kit must be ordered extra for field changeover.

•Not Available with LPG.

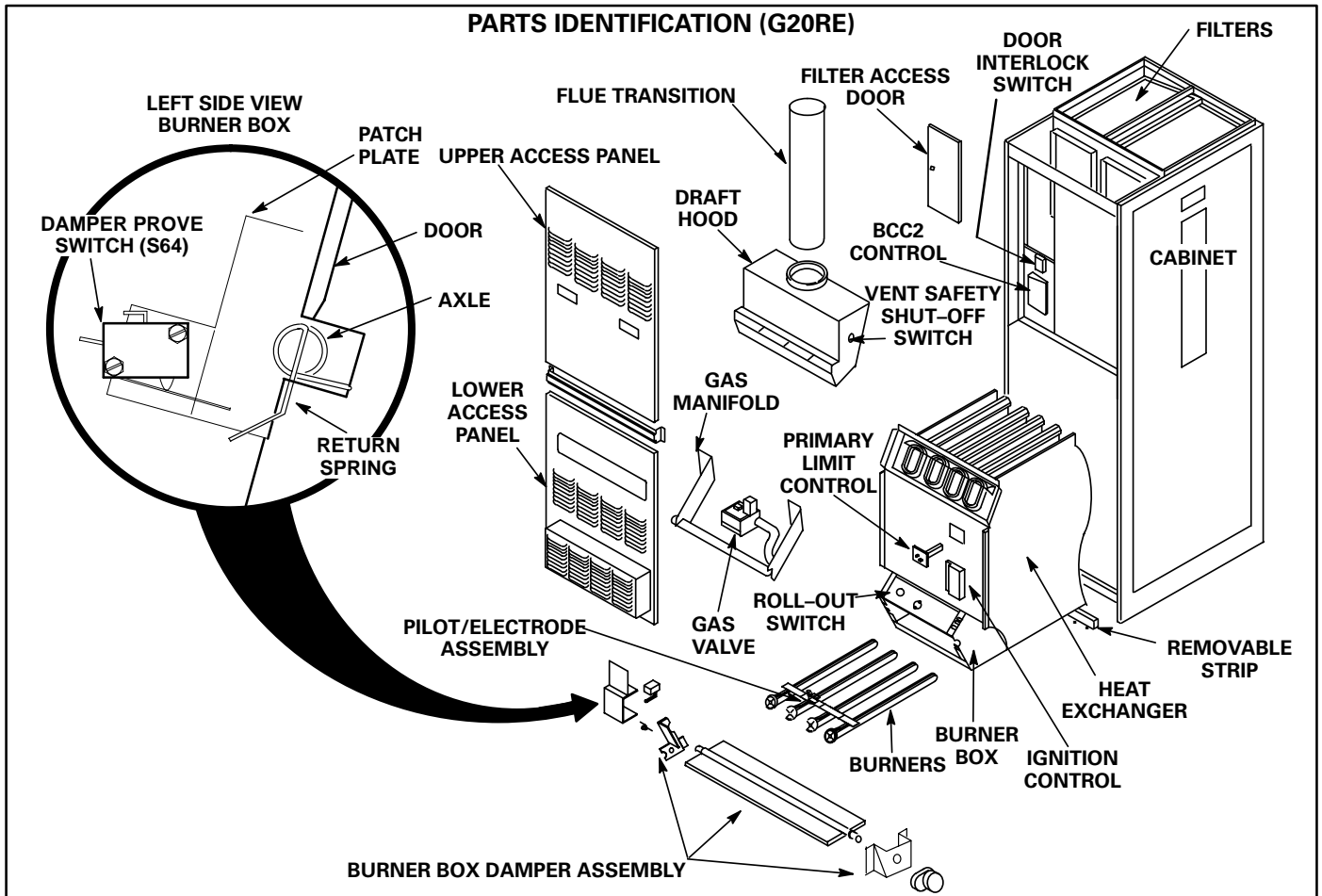

FIGURE 1

II – UNIT COMPONENTS

G20RE unit components are shown in figure 1. The blower controls can be accessed by removing the upper access panel. Gas valve and burners can be accessed by removing the lower access panel.

A – Control Box Components

The G20RE control box is shown in figure 2. It is located behind the lower access panel between the draft hood and the gas valve. The control box can be accessed by loosening the top screw and removing the bottom screw. The control box cover can then be rotated from the control box. The control box houses the (T1) Transformer and serves as a make-up box for low voltage field wiring. It also contains a grounding lug for the unit.

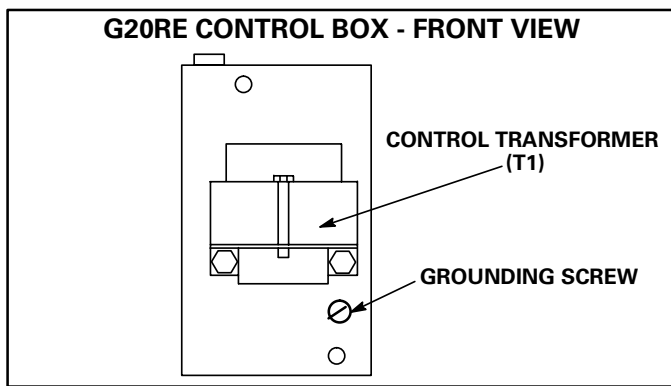

FIGURE 2

1 – Control Transformer (T1)

All G20RE series units use a single line voltage (120VAC) to 24VAC transformer. It is located inside the control box providing power to the low voltage section of the unit.

B – BCC2-2 Blower Control (A15)

All G20RE units utilize a BCC2-2 blower control as illustrated in figure 3. It is located behind the upper access panel on the BCC2-2 blower control panel. The BCC2-2 is a printed circuit board which controls the blower and monitors primary limit and gas valve operation. The control has a non-adjustable, factory preset "on" fan timing. Fan "off" timings are adjustable. The board is divided into two sections, 120VAC and 24VAC.

"CAB" and "XFMR" send 120VAC to the damper motor and transformer, respectively. Active cooling and heating blower speed terminals and three dummy "D" terminals are located on the 120VAC side of the BCC2-2. The "CF" terminal is used for wiring in the optional continuous fan kit. Also located on this side of the control are neutral terminals and a terminal for accessories such as an electronic air cleaner.

24VAC from transformer T1 is supplied to terminal "24V" on the 24VAC side of the BCC2-2. Thermostat connections and safety circuit terminals are also located on the 24VAC side of the control. Fan "off" timings may be adjusted by changing the position of a jumper across terminal pins.

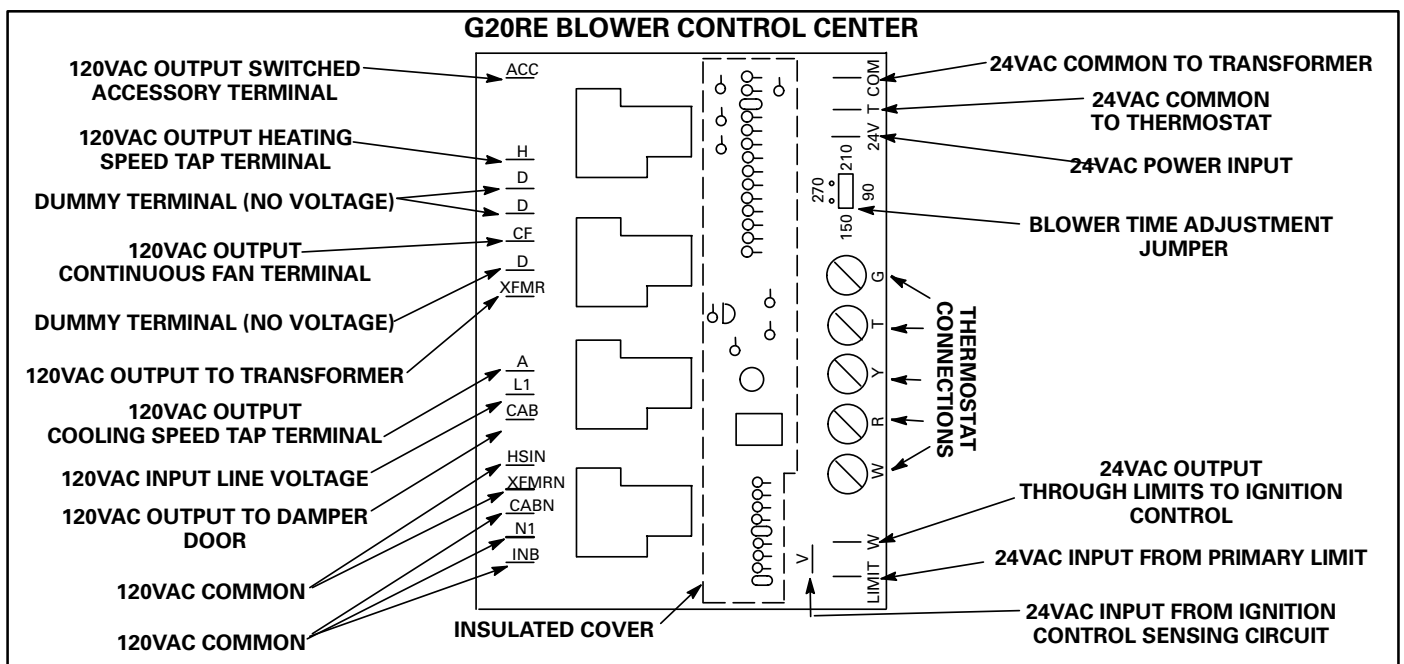

FIGURE 3

C – Blower Motors and Capacitors

All G20RE units use direct drive blower motors. All motors used are 120V permanent split capacitor motors to ensure maximum efficiency. See table 1 for ratings.

TABLE 1

G20R BLOWER RATINGS 120V 1PH		
BLOWER MOTOR	HP	CAP
Q2/3, Q3	1/3	5MFD 370V
Q4, Q3/4	1/2	7.5MFD 370V
Q5, Q4/5	3/4	40MFD 370V

D – Door Interlock Switch (S51)

A door interlock switch rated 16A at 125VAC is located behind the BCC2-2 blower control panel. The switch is wired in series with line voltage. When the blower door access panel is removed the unit will shut down.

E – Blocked Vent Switch (S62)

The blocked vent switch (S62) is located on the right side of the draft diverter. The switch is a high temperature N.C. SPST manual-reset limit connected in series with the ignition control A3. It trips when there is excess heat in the draft diverter or improper venting. The switch is factory set at $300^{\circ} \pm 12^{\circ}$ (149° C) and cannot be adjusted.

F – Flame Rollout Switch (S47)

Flame rollout switch is a high temperature limit located on top of the burner box. The limit is a N.C. SPST manual-reset limit connected in series with the ignition control A3. When S47 senses rollout, the ignition control immediately stops ignition and closes the gas valve. If unit is running and flame rollout is detected, the gas valve will close and ignition control will be disabled. The switch is factory set and cannot be adjusted. See table 2. The switch can be manually reset.

TABLE 2

FLAME ROLLOUT SWITCH SETPOINTS	
HEATING INPUT KBTUH	SETPOINT
50, 75	$260^{\circ}\text{F} \pm 12^{\circ}\text{F}$
100, 125, 150	$300^{\circ}\text{F} \pm 12^{\circ}\text{F}$

G – Primary Limit Control (S10)

The primary limit switch (S10) on all units is located in the middle of the heating vestibule wall. G20RQ2/3(X)E-50, Q3(X)E-75, Q4(X)E-75, Q3/4(X)E-100 and Q3(X)E-125 units use a SPST self resetting limit. See figure 4. When excess heat is sensed in the heat exchanger, the limit switch will open and interrupt the

current to the gas valve. If the limit is tripped, BCC2-2 energizes the blower. The limit automatically resets when unit temperature drops below the reset point. See table 3.

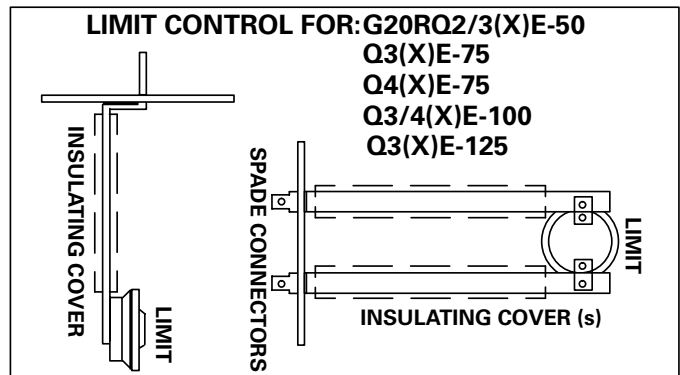

FIGURE 4

All other units use a fan control-type limit shown in figure 5. It is used to protect the unit from high temperatures. The blower limit is a resistive-type bimetal SPST automatic resetting switch. This control does not contain a fan control. The control is factory preset and is not adjustable. See table 3.

TABLE 3

PRIMARY LIMIT TEMPERATURES		
UNIT MODEL NO.	TEMP. RISE	TEMP. FALL
G20RQ2/3(X)E-50 Series	$230^{\circ}\text{F} \pm 5^{\circ}\text{F}$	$200^{\circ}\text{F} \pm 8^{\circ}\text{F}$
G20RQ3(X)E-75 Series		
G20RQ4(X)E-75 Series		
G20RQ3/4(X)E-100 Series	$190^{\circ}\text{F} + 10^{\circ}\text{F} - 5^{\circ}\text{F}$	$160^{\circ}\text{F} \pm 10^{\circ}\text{F}$
G20RQ5(X)E-100 Series	$150^{\circ}\text{F} \pm 15^{\circ}\text{F}$	$150^{\circ}\text{F} \pm 15^{\circ}\text{F}$
G20RQ3(X)E-125 Series	$250^{\circ}\text{F} \pm 6^{\circ}\text{F}$	$220^{\circ}\text{F} \pm 10^{\circ}\text{F}$
G20RQ4/5(X)E-125 Series	$180^{\circ}\text{F} \pm 15^{\circ}\text{F}$	$180^{\circ}\text{F} \pm 15^{\circ}\text{F}$
G20RQ4/5(X)E-150 Series		

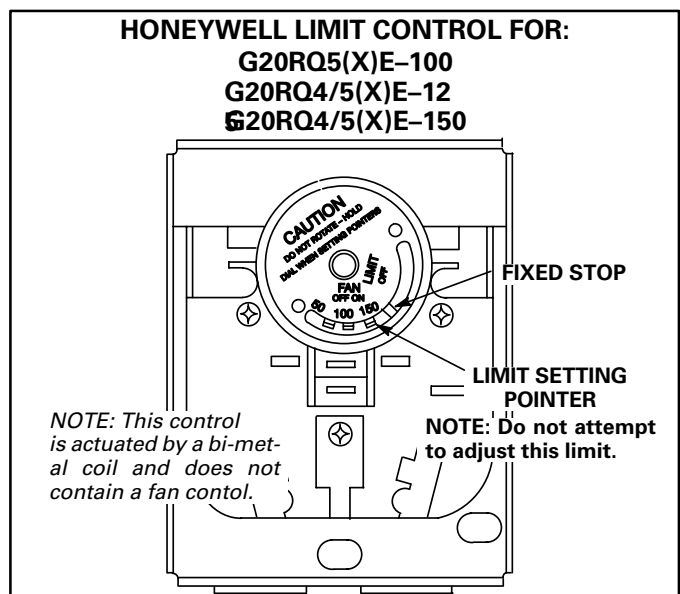

FIGURE 5

H – Secondary Limit (S21)

The secondary limit switch (S21) is a high temperature limit located on the left side of the blower scroll. The limit is a N.C. SPST auto-reset limit connected in series with the ignition control A3. The switch is similar in design to the primary limit control. See figure 4. The limit detects heat in the blower compartment indicating a possible fan failure. When S21 senses heat, the ignition control immediately stops ignition and closes the gas valve. If unit is running and heat is detected, the gas valve will close and ignition control will be disabled. The switch is factory set and cannot be adjusted. See table 4. The switch automatically resets.

TABLE 4

SECONDARY LIMIT TEMPERATURES		
UNIT MODEL NO.	TEMP. RISE	TEMP. FALL
G20RQ2/3(X)E-50 Series	140°F ± 5°F	110°F ± 10°F
G20RQ3(X)E-75 Series		
G20RQ4(X)E-75 Series	130°F ± 5°F	100°F ± 10°F
G20RQ3/4(X)E-100 Series	140°F ± 5°F	110°F ± 10°F
G20RQ5(X)E-100 Series	120°F ± 5°F	90°F ± 10°F
G20RQ3(X)E-125 Series		
G20RQ4/5(X)E-125 Series		
G20RQ4/5(X)E-150 Series	130°F ± 5°F	100°F ± 10°F

I – Gas Valve (Figure 6)

All G20RE units use a Robertshaw gas valve. All gas valves are internally redundant to assure safety shut-off. If the gas valve must be replaced, the same type valve must be used.

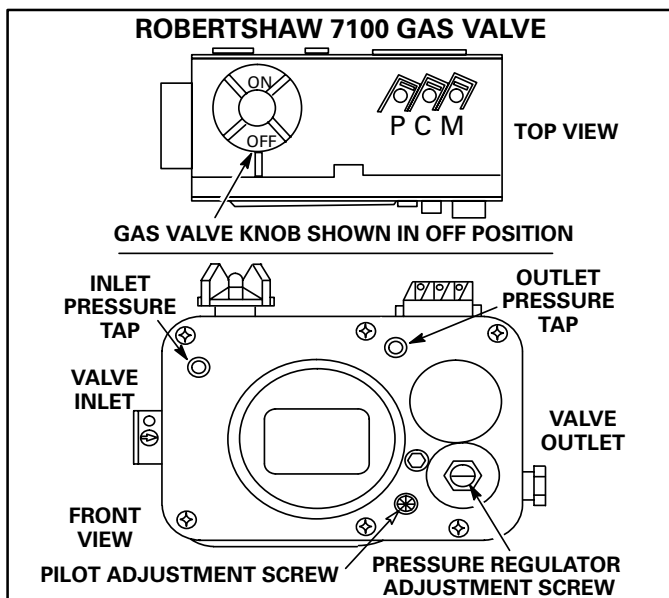

FIGURE 6

J – Electronic Ignition Control (Figure 7)

The Robertshaw electronic ignition control (A3) is an intermittent ignition control module located on the vestibule panel. See figure 1. When there is a call for heat, the control generates a spark to ignite the pilot, after which the control senses the flame. If the flame current is too weak (less than 1 microamp) the control will shut down and de-energize the gas valve. Flame current should be between 1 and 5 microamps.

⚠ DANGER

Shock Hazard.

Spark related components contain high voltage. Disconnect power before servicing unit. The ignition control is not field repairable.

Can cause unsafe operation, injury or death.

The 24VAC terminals and the gas knob are located on top of the valve. All terminals on the gas valve are connected to wires from the electronic ignition control. The left red wire to terminal "P" energizes the pilot valve. An orange sensing wire from terminal "V" (marked VALVE SENSE) of the BCC2-2 control rides "piggy back" on the "P" terminal connection. The main valve, terminal "M," is energized by the right red wire. The blue wire, terminal "C," is the common for the gas valve.

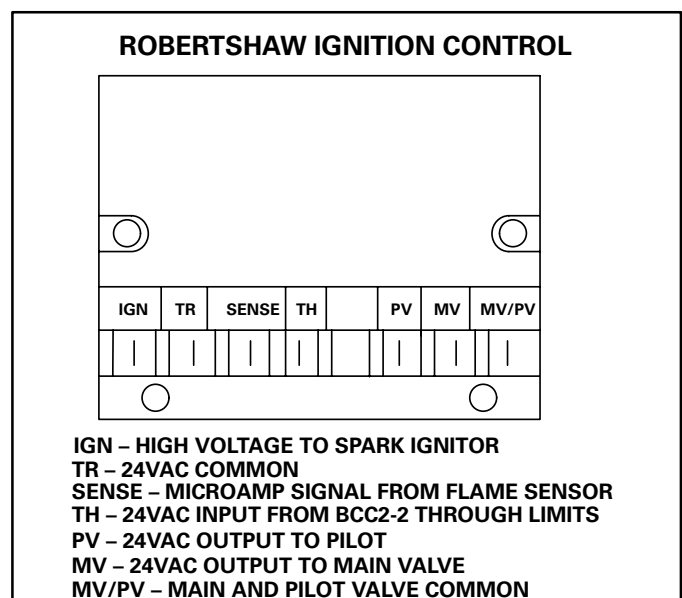

FIGURE 7

K – Pilot Tube, Ignition Wire and Flame Rod

The pilot tube from the gas valve and the flame sensor and ignition wires from the electronic ignition control enter through the top of the burner box to the pilot burner assembly.

Figure 8 shows the clearance between top of the pilot burner head and the top of the main burner surface.

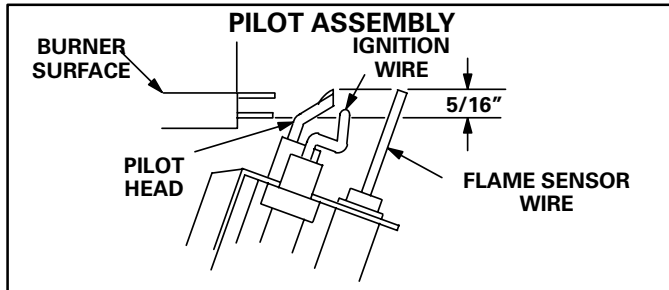

FIGURE 8

L – Burner Box/Damper Door

The damper motor is located on the right side of the burner box. On the left side of the burner box, behind a protective plate is the damper prove switch. Refer to figure 9. The burner box top is removable on all units.

When there is a call for heat, the damper motor is energized and damper door opens as the damper motor axle begins to rotate.

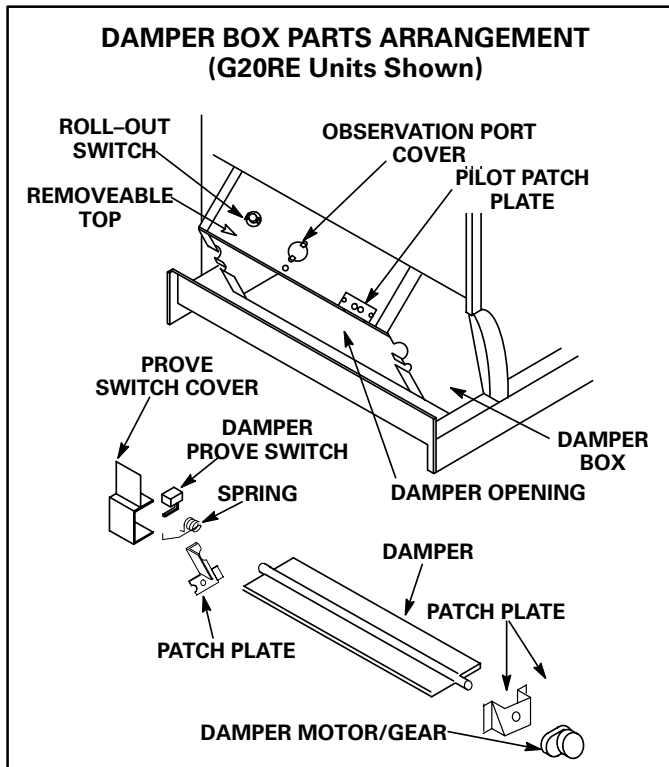

FIGURE 9

M – Damper Prove Switch (S64)

The spring, which is held by a notch in the burner box frame, activates the damper prove switch as the damper door opens. See figure 10. The axle rotates the damper door to open position. As the axle turns, the spring winds backward to make contact with the damper prove switch. The protective cover plate is removable (one screw) and the spring may be unclipped for service to the damper door or burner box. Spring must be removed in order to remove the damper door.

After service is complete, the spring must rest snugly in notch for damper prove switch to function properly. Do not force door open, damage to the spring and motor may occur. Take care to open damper door slowly.

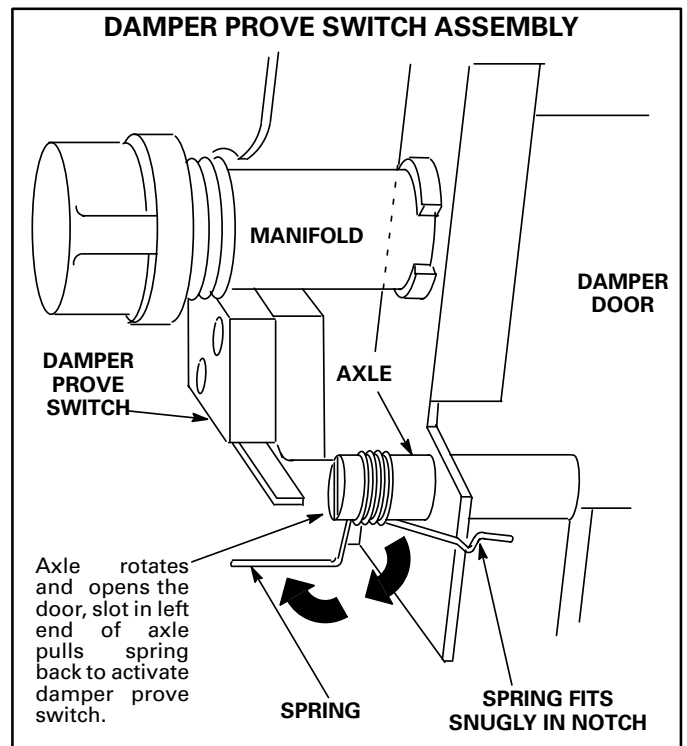

FIGURE 10

III – PLACEMENT AND INSTALLATION

Make sure the unit is installed in accordance with installation instructions and all applicable codes.

IV – START-UP

A – Preliminary and Seasonal Checks

- 1 – Inspect electrical wiring, both field and factory installed for loose connections. Tighten as required.
- 2 – Check voltage at disconnect switch. Voltage must be within range listed on the nameplate. If not, consult the power company and have voltage condition corrected before starting unit.

B – Heating Start-Up

⚠ WARNING

Shock and burn hazard.

G20RE and G20RXE units are equipped with an intermittent pilot ignition system. Do not attempt to light manually.

- 1 – Set thermostat to OFF position. Close manual knob on gas valve.
- 2 – Wait 5 minutes.
- 3 – Open manual knob on gas valve, replace burner access door and turn on unit electrical supply.
- 4 – Set fan switch to AUTO or ON and move system selection switch to HEAT. Adjust thermostat to a setting above room temperature.
- 5 – If unit does not light the first time, it will attempt one more ignition before locking out.
- 6 – If lockout occurs, repeat steps 1, 2, 3 and 4.

C – Safety or Emergency Shutdown

Turn off power to unit. Close manual and/or main gas valves.

D – Extended Period Shutdown

Turn off thermostat or set to “UNOCCUPIED” mode. Close all gas valves (both internal and external to unit) to guarantee no gas leak into combustion chamber. Turn off power to unit. All access panels, covers and vent caps must be in place and secured.

V – HEATING SYSTEM SERVICE CHECKS

A – A.G.A. Applications and Requirements

All units are A.G.A. design certified without modifications. Refer to the G20RE Operation and Installation Instruction Manual Information.

B – Gas Piping

Gas supply piping should not allow more than 0.5”W.C. drop in pressure between gas meter and unit. Supply gas pipe must not be smaller than unit gas connection.

Compounds used on gas piping threaded joints should be resistant to action of liquefied petroleum gases.

C – Testing Gas Piping

⚠ IMPORTANT

In case emergency shutdown is required, turn off the main shut-off valve and disconnect the main power to unit. These controls should be properly labeled by the installer.

When pressure testing gas lines, the gas valve must be disconnected and isolated. Gas valves can be damaged if subjected to more than 0.5psig (14” W.C.). See figure 11. If the pressure is equal to or less than 0.5psig (14”W.C.), use the manual shut-off valve before pressure testing to isolate furnace from gas supply.

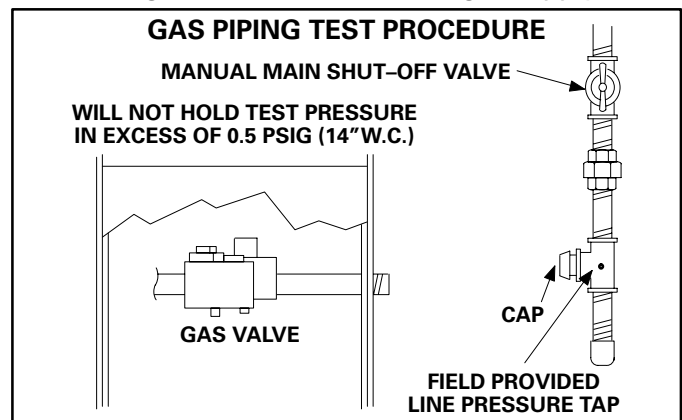

FIGURE 11

When checking piping connections for gas leaks, use preferred means. Kitchen detergents can cause harmful corrosion on various metals used in gas piping. Use of a specialty Gas Leak Detector is strongly recommended. It is available through Lennox under part number 31B2001. See Corp. 8411-L10, for further details.

Do not use matches, candles, flame or any other source of ignition to check for gas leaks.

D – Testing Gas Supply Pressure

When testing supply gas pressure, connect test gauge to inlet pressure tap (field provided). See figure 11. Test supply gas pressure. Low pressure may result in erratic operation or underfire. High pressure can result in permanent damage to gas valve or overfire. For natural gas units, operating pressure at unit gas connection must be between 4.5” W.C. and 10.5” W.C. For L.P. gas units, operating pressure at unit gas connection must be between 10.5” W.C. and 13.5” W.C.

On multiple unit installations, each unit should be checked separately, with and without units operating. Supply pressure must fall within range listed in previous paragraph.

E – Check Manifold Pressure

After line pressure has been checked and adjusted, check manifold pressure. Move pressure gauge to outlet pressure tap located on unit gas valve (GV1). See figure 6 for location of pressure tap on gas valve.

IMPORTANT

For safety, connect a shut-off valve between the manometer and the gas tap to permit shut off of gas pressure to the manometer.

The gas valve is factory set and should not require adjustment. All gas valves are factory regulated. See table 5 . See tables 6 and 7 for derated manifold pressure values in high altitude application for natural and LP gases.

**TABLE 5
GAS VALVE REGULATION**

Unit (Fuel)	Operating Pressure (outlet) in. W.C.
Natural	3.5 +0 -0.3
L.P.	9.5 ± 0.5

Manifold Adjustment Procedure:

- 1 – Connect a test gauge to outlet pressure tap on gas valve. Start unit and allow 5 minutes for unit to reach high fire steady state.
- 2 – While waiting for the unit to stabilize, notice the flame. Flame should be stable and should not lift from burner. Natural gas should burn blue. L.P. gas should burn mostly blue with some orange streaks.
- 3 – After allowing unit to stabilize for 5 minutes, record manifold pressure and compare to values given in table 5.

NOTE– Disconnect heating demand as soon as an accurate reading has been obtained.

F – Proper Gas Flow

To check for proper gas flow to combustion chamber, determine Btuh input from unit rating plate or table or the specifications tables on pages 1 and 2. Divide input rating by Btuh per cubic foot of available gas. Result is the number of cubic feet per hour required. Determine flow of gas through gas meter for two minutes . Multiply by 30 to get hourly flow of gas to burner.

NOTE– To obtain accurate reading, shut off all other gas appliances connected to meter.

G – High Altitude Derate

C.G.A. certified units used in high altitude applications are factory equipped with modifications that eliminate the need for manifold pressure adjustment to obtain proper heat input. Check the unit rating plate to make sure unit is a high altitude unit.

A.G.A. certified units must be derated when installed at an elevation of 2,000 ft. (610 m) or more above sea level. Tables 6 and 7 show the derated manifold pressure for high altitude operation with both natural and LP/ Propane gas. Operating this appliance at the manifold pressure specified on the tables will ensure proper unit heat input at high altitude. Consult your gas utility for the local natural gas heating value.

NOTE–This is the only permissible field derate for this appliance.

**TABLE 6
HIGH ALTITUDE MANIFOLD PRESSURE
DERATE FOR NATURAL GAS UNITS**

Altitude (Ft.)	*Heating Value (Btu/Ft#)				
	900	950	1000	1050	1100
0	4.32" wc	3.88" wc	3.50" wc	3.17" wc	2.89" wc
1000	4.32" wc	3.88" wc	3.50" wc	3.17" wc	2.89" wc
2000	3.65" wc	3.30" wc	2.95" wc	2.70" wc	2.45" wc
3000	3.35" wc	3.00" wc	2.70" wc	2.45" wc	2.25" wc
4000	3.05" wc	2.75" wc	2.45" wc	2.25" wc	--
5000	2.77" wc	2.48" wc	2.25" wc	--	--
6000	2.50" wc	2.25" wc	--	--	--

**Heating value based on atmospheric pressure of 30" mercury and temperature of 60° F (16° C).*

**TABLE 7
HIGH ALTITUDE MANIFOLD PRESSURE
DERATE FOR LP/PROPANE GAS UNITS**

ALTITUDE (Ft.)	0	1000	2000	3000	4000	5000	6000
MANIFOLD PRESSURE	9.5" w.c.	9.5" w.c.	8.0" w.c.	7.2" w.c.	6.5" w.c.	5.9" w.c.	5.3" w.c.

IMPORTANT

For safety, shut unit off and remove manometer as soon as an accurate reading has been obtained. Take care to replace pressure tap plug.

H – Flame Signal

Flame signal or microamp is an electrical current which passes from the ignition control through the sensor electrode during unit operation. Current passes from the sensor through the flame to ground to complete a safety circuit. A 50 microamp DC meter is needed to check flame signal on the primary ignition control.

To Measure Flame Signal:

- 1 – Place meter in series between ignition control and sensor wire. Connect the positive (+) lead of meter to the ignition control sensor connection and the negative (-) lead of the meter to the sensor wire. See figure 12.
- 2 – Set thermostat for a heating demand and check flame signal with unit operating. For G20RE series, a reading of 1 to 5 microamps DC should occur.

Flame signal may rise above 1 to 5 microamps for the first few seconds after ignition and then level off.

⚠ WARNING

Fire and explosion hazard.
These instructions MUST be followed exactly.
Can cause a fire or explosion resulting in property damage, personal injury or loss of life.

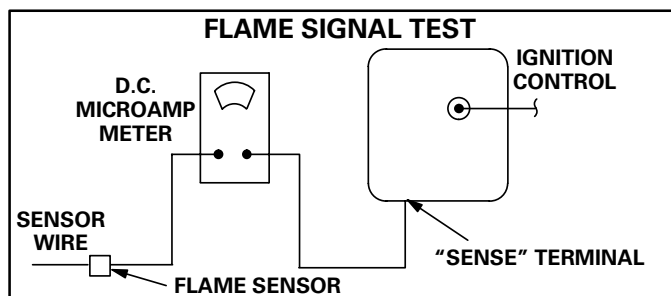

VI – BLOWER OPERATION/ADJUSTMENT

NOTE– The following is a generalized procedure and does not apply to all thermostat controls.

- A – Blower operation is dependent on thermostat control system.
- 1 – Generally, blower operation is set at thermostat subbase fan switch. With fan switch in ON position, blower operates continuously. With fan switch in AUTO position, blower cycles with demand or runs continuously while heating or cooling circuit cycles.
 - 2 – In all cases, blower and entire unit will be off when the system switch is in OFF position.

B – Temperature Rise

Temperature rise for G20RE units depends on unit output, blower speed and static pressure of the unit setup. Blower speed must be set for unit operation within range of "AIR TEMP. RISE ° F" listed on the unit rating plate.

To Measure Temperature Rise:

- 1 – Place plenum thermometers in the supply and return air plenums. Locate thermometers in the first horizontal run of the warm air plenum where it will not pick up radiant heat from the heat exchanger.
- 2 – Set thermostat to highest setting.
- 3 – After plenum thermometers have reached their highest and steadiest readings, subtract the two readings. The difference should be in the range listed on the unit rating plate. If the temperature is too low, decrease blower speed. If temperature is too high, first check the firing rate. Provided the firing rate is acceptable, increase blower speed to reduce temperature. To change blower speed taps see the Blower Speed Taps section in this manual.

C – Discharge Static Pressure

- 1 – Measure tap locations as shown in figure 13.
- 2 – Punch a 1/4" diameter hole in supply and return air plenums. Insert manometer hose flush with inside edge of hole or insulation. Seal around the hose with permagum. Connect the zero end of the manometer to the discharge (supply) side of the system. On ducted systems, connect the other end of manometer to the return duct as above. For systems with non-ducted returns, leave the other end of the manometer open to the atmosphere.
- 3 – With only the blower motor running and the evaporator coil dry, observe the manometer reading. Adjust blower motor speed to deliver the required amount of air.
- 4 – Discharge static pressure drop must not be more than 0.5" W.C.
- 5 – Seal around the hole when the check is complete.

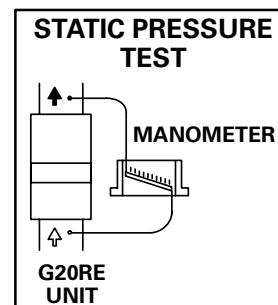

D – Blower Speed Taps

Blower speed tap selection is accomplished by changing the taps at the harness connector at the blower motor. Disconnect harness connector from motor to expose speed selectors. Blower speed selections are listed in table 8.

To Change Blower Speed:

- 1 – Turn off electric power to furnace.
- 2 – Remove upper access panel and filter access door. See figure 1.
- 3 – Lift left side filter over left support angle. For easy handling, hold filter at center bottom.
- 4 – Rotate filter sideways and pull it through the blower access panel opening.
- 5 – Pull the second filter out the same way as the first.
- 6 – Grasp blower motor harness connector located on back on motor. Depress lock tab and pull connector from motor.
- 7 – Pull harness connector and wires through blower access panel opening.
- 8 – Select desired speeds for heating and cooling. (Red = heating, Black = cooling, White = common). See table 8.

TABLE 8

BLOWER SPEED SELECTION						
UNIT	Factory Connected Speed Taps		Motor Speeds Available			
	Cool	Heat				
G20RQ2/3(X)E-50*	2	4	4			
G20RQ3(X)E-75	2	5	4			
G20RQ4(X)E-75	2	4	4			
G20RQ3/4(X)E-100	2	4	4			
G20RQ5(X)E-100	3	6	5			
G20RQ3(X)E-125	2	4	4			
G20RQ4/5(X)E-125	3	6	5			
G20RQ4/5(X)E-150	3	6	5			
BLOWER SPEED SELECTION HI ← → LOW						
SPEED	◇ 2	3	4	5	4	
TAPS	◇ 2	3	4	5	6	5
*DO NOT USE LOW SPEED TAP ON Q2/3-50 ◇ MOTOR PLUG SPEED TAP DESIGNATION						

- 9 – Depress harness connector tab to release wire terminal. Select connector location for new speed (refer to unit wiring diagram). Insert wire terminal until it is securely in place. See figure 14.
- 10 – Replace harness connector to motor .

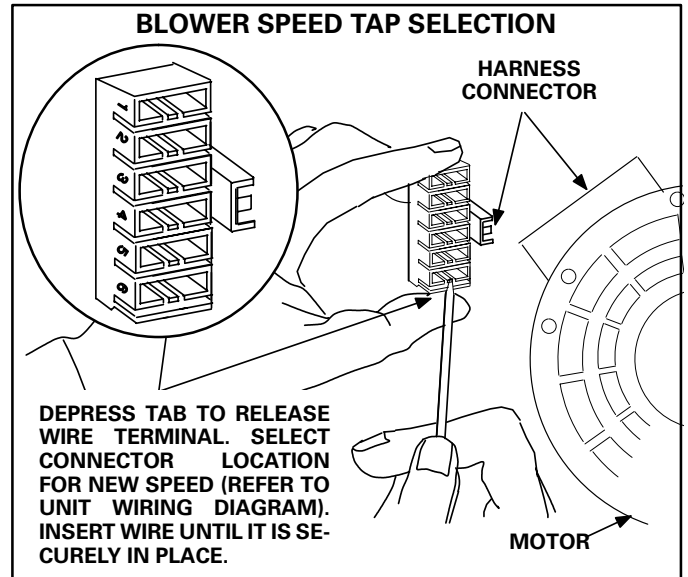

FIGURE 14

E – Fan Timings

Fan “off” timings (time that the blower operates after the heat demand has been satisfied) are determined by the arrangement of a jumper across pins on the BCC2-2 blower control board. See figure 3. To adjust fan “off” timings, gently disconnect jumper and re-position across pins corresponding with new timing. Fan “on” time is factory set at 45 seconds and is not adjustable.

⚠ WARNING

Shock hazard.

Make sure to disconnect power before changing fan “OFF” timings.

Can cause personal injury.

Figure 15 shows the various fan “off” timings and how jumper should be positioned. Unit is shipped with a factory fan “off” setting of 90 seconds. Fan “off” time will affect comfort and efficiency and is adjustable to satisfy individual applications.

⚠ IMPORTANT

Potential for improper operation.

If fan “OFF” timing is set too low, residual heat in heat exchanger may cause primary limit S10 to trip resulting in frequent cycling of blower. If this occurs, adjust blower to longer time setting.

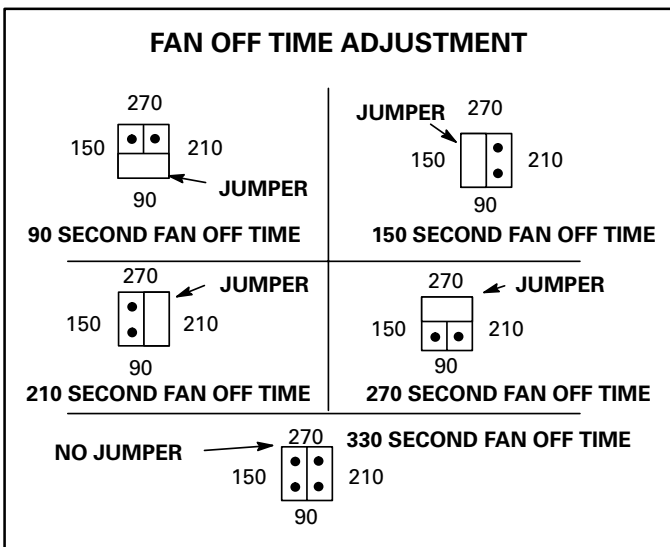

FIGURE 15

VII – MAINTENANCE

At the beginning of each heating season, the system should be checked as follows:

A – Filters

G20RE and G20RXE series units are equipped with permanent internal filters which should be inspected monthly and cleaned when necessary to assure proper furnace operation. Use the following procedure to clean filter. Refer to figure 16.

To Inspect/Clean Filters:

- 1 – Turn off electric power to furnace.
- 2 – Remove upper access panel and filter access door. See figure 1.
- 3 – Lift left side filter over left support angle. For easy handling, hold filter at center bottom.
- 4 – Rotate filter sideways and pull it through the blower access panel opening.
- 5 – Pull the second filter out the same way as the first.
- 6 – Wash filters with warm water and mild detergent. When dry, filters should be sprayed with filter handicoater before replacing. Filter Handicoater is RP products coating no. 418 and is available as Lennox part no. P-8-5069.
- 7 – Right filter should rest under tab of right filter support angle.
- 8 – Left filter must rest against top edge of right filter.

B – Supply Air Blower

- 1 – Check and clean blower wheel.
- 2 – Motors used on G20RE series units are permanently lubricated and need no further lubrication.

C – Flue and Chimney

Check flue pipe, chimney and all connections for tightness and to make sure there is no blockage or leaks.

D – Cleaning Heat Exchanger and Burners

NOTE—Use papers or protective covering in front of furnace while cleaning furnace.

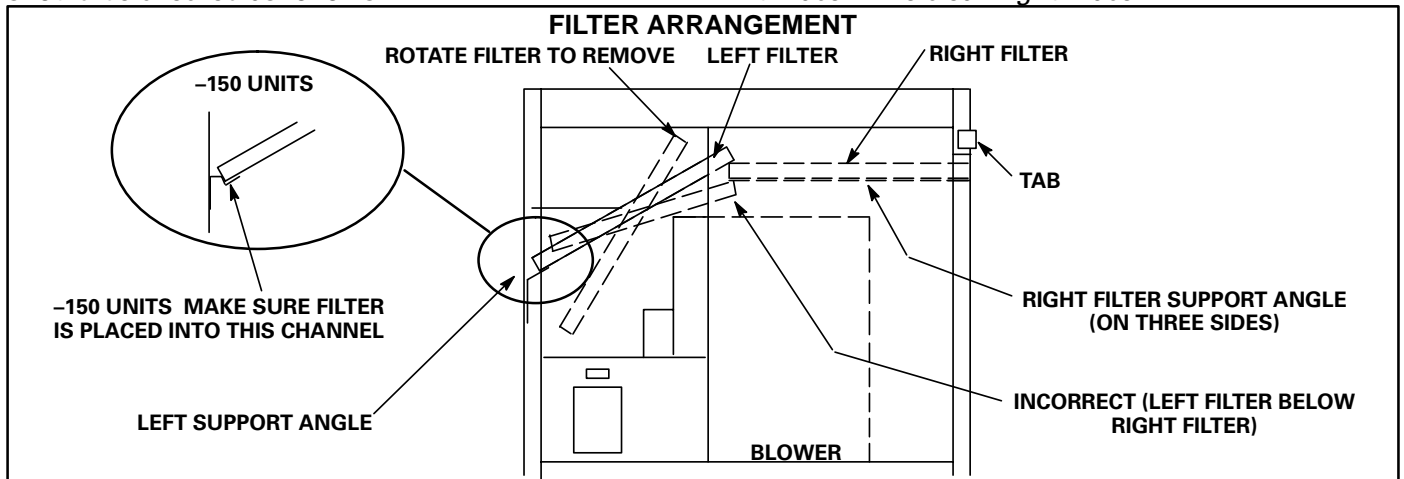

FIGURE 16

To clean heat exchanger:

- 1 – Turn off both electrical and gas power supplies to furnace. Refer to figures 1 and 9 during disassembly and reassembly procedures.
- 2 – Remove upper and lower access panels.
- 3 – Remove screws holding burner box damper in place and remove burner box damper assembly and damper prove switch cover.
- 4 – Remove screws securing removable burner box cover and remove burner box cover.
- 5 – Remove flue pipe and draft hood (figure 17).

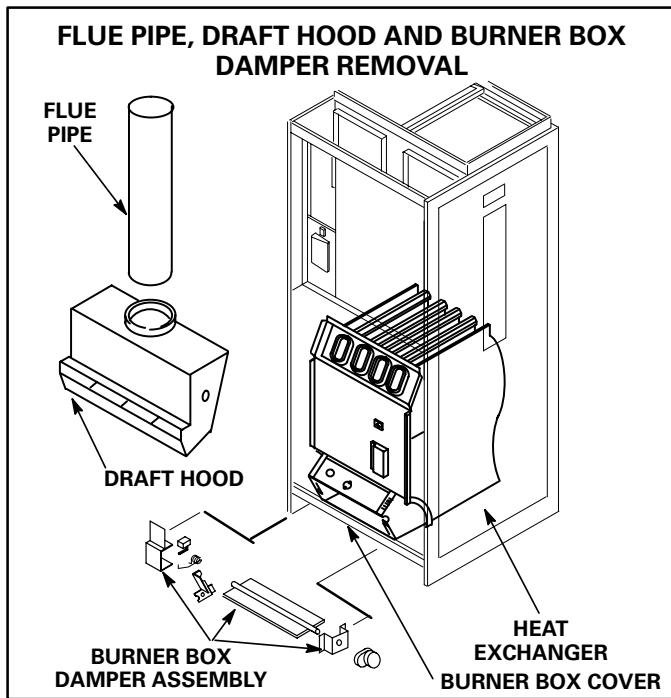

FIGURE 17

- 6 – Remove flue restrictor over flue outlet (50E only).
- 7 – Gas manifold, gas valve and burners do not need to be removed and can be left in place.
- 8 – Insert a 2 ft. steel rod with a 20 in. length of chain attached to one end into top opening of heat exchanger. Refer to figure 18.
- 9 – Shake rod to drop chain through clamshell into burner cavity in bottom of heat exchanger.

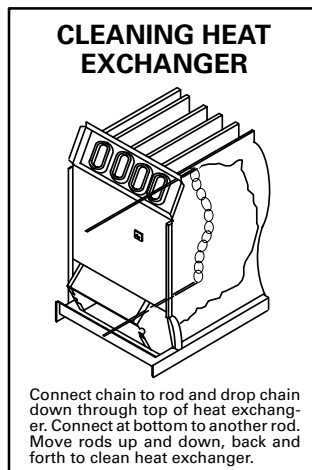

FIGURE 18

- 10 – Attach bottom of chain to 2 ft. (600 mm) rod.
- 11 – Push and pull the rods back and forth and up and down with a vigorous motion. The chain will dislodge the soot and scale deposits inside the heat exchanger. Repeat for each clamshell.
- 12 – With a shop vacuum or rags, clean out soot and scale deposits from bottom of heat exchanger.

To clean burners:

NOTE—FOR UNITS WITH FLAME RODS, remove two springs and withdraw rods from back of burner. Clean flame rods with wire brush. Continue with items 13 through 15 below and reinstall flame rods and springs.

- 13 – Disconnect gas piping.
- 14 – Remove screws holding gas manifold in place and pull burners from heat exchanger.
- 15 – Clean top of burner ports with a wire brush. See figure 19.

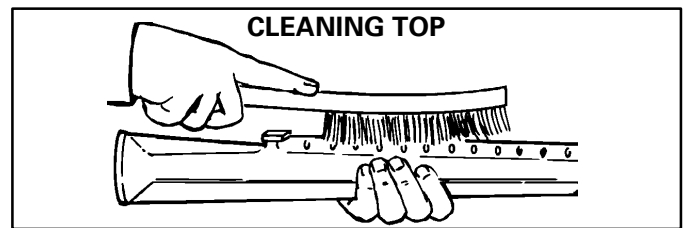

FIGURE 19

- 16 – Clean burner ports by inserting a cleaning tool (made from a piece of sheet metal cut to fit the burner ports) and work in and out of each port. See figure 20.

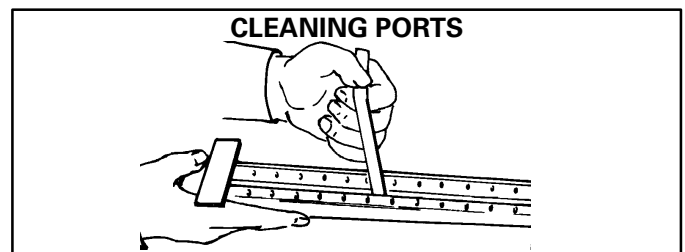

FIGURE 20

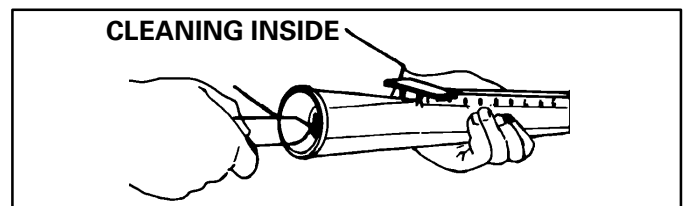

FIGURE 21

17 – Clean inside of each burner with a bottle cleaning brush. See figure 21.

18 – Replace burners making sure to fully engage in rear receiving slot in heat exchanger. See figure 22. Resecure gas manifold and supply piping.

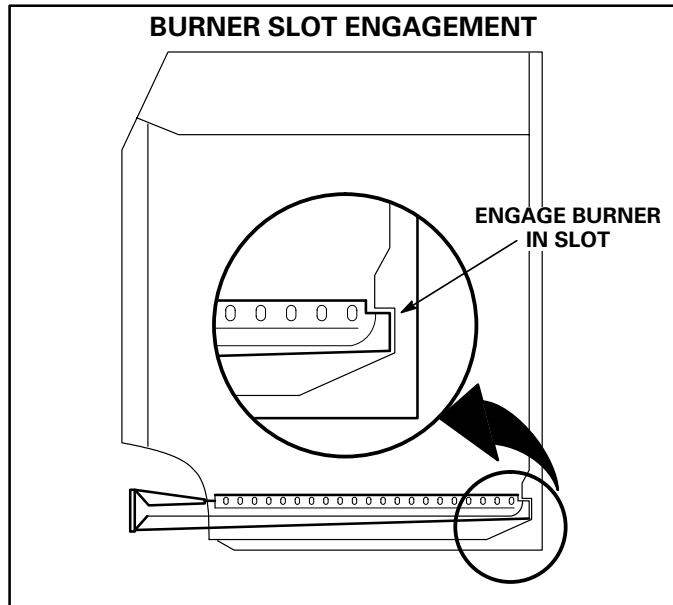

FIGURE 22

19 – Resecure damper assembly, damper prove switch cover and burner box top. Carefully open damper by hand to ensure that the damper spring closes damper correctly and that the damper prove switch is engaged when damper is open.

⚠ CAUTION

Potential for unit damage.

Use extreme care when opening damper door to prevent permanent damage to the damper door.

Can cause damage to damper motor resulting in improper furnace operation.

20 – Install flue restrictor (50E models only).

21 – Before replacing draft hood, flue pipe and access panels, inspect draft hood gasket. Replace gasket if necessary.

22 – Carefully check all piping connections (factory and field) for gas leaks. Use a leak detecting solution or other preferred means.

⚠ CAUTION

Potential for gas leaks, fire or explosion.

Some soaps used for leak detection are corrosive to certain metals. Carefully clean piping thoroughly after leak detection has been completed.

Can cause damage to piping resulting in gas leaks, fire or explosion.

23 – Turn on gas and electrical supply.

E – Electrical

1 – Check all wiring for loose connections.

2 – Check for correct voltage.

3 – Check amp-draw on blower motor.

KEY	DESCRIPTION
A3	control, burner, ignition
A15	control, blower, bcc2
B3	motor, blower
B17	motor, damper
C4	capacitor, blower motor
GVI	valve, gas
J20	jack, gas
J35	jack, test
J43	jack, blower motor
K3,-1	relay, blower
K13,-1	relay, combustion air
K36,-1	relay, heat blower
K109,-1	relay, accessory
P20	plug, gas
P35	plug, test
P43	plug, blower motor
S1	thermostat, room
S10	limit, primary, gas
S21	limit, secondary, gas
S47	switch, flame, rollout
S51	switch, door interlock
S62	switch, vent safety
S64	switch, damper prove
T1	transformer, control

UNIT	FACTORY CONNECTED SPEED TAPS		MOTOR SPEEDS AVAILABLE
	COOL	HEAT	
Q2/3-50	2	4	4*
Q3-75	2	5	4
Q3-125, Q3/4, Q4	2	4	4
Q4/5, Q5	3	6	5

SPEED TAPS	BLOWER SPEED SELECTION				
	HI	←	→	LO	
2	2	3	4	5	4
3	2	3	4	5	6
4	2	3	4	5	6
5	2	3	4	5	6
6	2	3	4	5	6

*DO NOT USE LOW SPEED TAP ON Q2/3-50

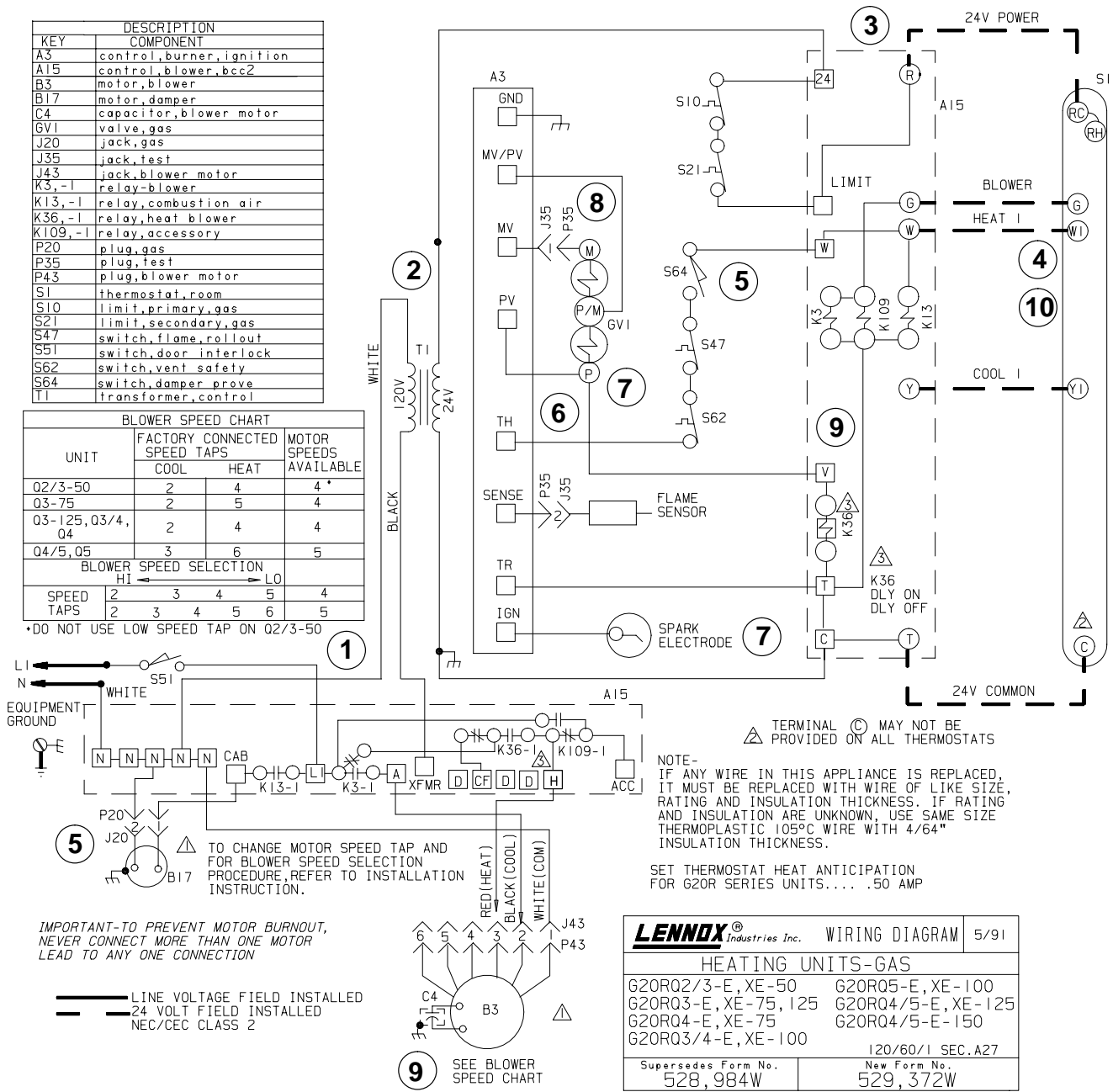

TERMINAL (C) MAY NOT BE PROVIDED ON ALL THERMOSTATS

NOTE- IF ANY WIRE IN THIS APPLIANCE IS REPLACED, IT MUST BE REPLACED WITH WIRE OF LIKE SIZE, RATING AND INSULATION THICKNESS. IF RATING AND INSULATION ARE UNKNOWN, USE SAME SIZE THERMOPLASTIC 105°C WIRE WITH 4/64" INSULATION THICKNESS.

SET THERMOSTAT HEAT ANTICIPATION FOR G20R SERIES UNITS... .50 AMP

IMPORTANT-TO PREVENT MOTOR BURNOUT, NEVER CONNECT MORE THAN ONE MOTOR LEAD TO ANY ONE CONNECTION

— LINE VOLTAGE FIELD INSTALLED
 - - 24 VOLT FIELD INSTALLED
 NEC/CEC CLASS 2

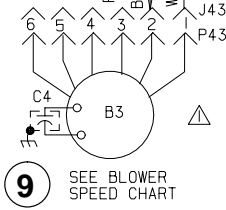

9 SEE BLOWER SPEED CHART

LENNOX [®] Industries Inc.	WIRING DIAGRAM	5/91
HEATING UNITS-GAS		
G20RQ2/3-E, XE-50	G20RQ5-E, XE-100	
G20RQ3-E, XE-75, 125	G20RQ4/5-E, XE-125	
G20RQ4-E, XE-75	G20RQ4/5-E-150	
G20RQ3/4-E, XE-100		
120/60/1 SEC. A27		
Supersedes Form No. 528, 984W	New Form No. 529, 372W	

Litho U.S.A.

SEQUENCE OF OPERATION

- When disconnect is closed, 120V feeds to line voltage side of the blower control (A15). Door interlock switch (S51) must be closed for A15 to receive voltage.
- A15 supplies 120V to transformer (T1).
- T1 supplies 24VAC to terminal "24" on A15. In turn, terminal "R" of A15 supplies 24VAC to terminal "RC" of the thermostat (S1).
- When there is a call for heat, W1 of the thermostat energizes W of the blower control with 24VAC.
- CAB of the blower control energizes the damper motor (B17) which opens the damper door. When door is in full open position, damper prove switch (S64) closes.
- When S64 closes, assuming flame rollout switch (S47) and vent safety switch (S62) are closed, 24VAC is supplied to "TH" terminal of electronic ignition control (A3).
- Through the electronic ignition control, the pilot valve "P" of the gas valve opens. The spark electrode ignites the pilot and the flame sensor senses the pilot.
- When flame is sensed the main gas valve opens and supplies the burners with gas.
- Terminal "V" (Valve Sense) of the blower control senses that the gas valve is energized and initiates a 45 second time delay. At the end of the 45 seconds the blower, (B3) is energized.
- When the heat demand has been satisfied, W1 of the thermostat de-energizes the gas valve and damper spring closes the damper door. As the damper door closes, the damper prove switch opens. The blower runs for a designated period (90-330 sec.) as set by jumper on blower control.