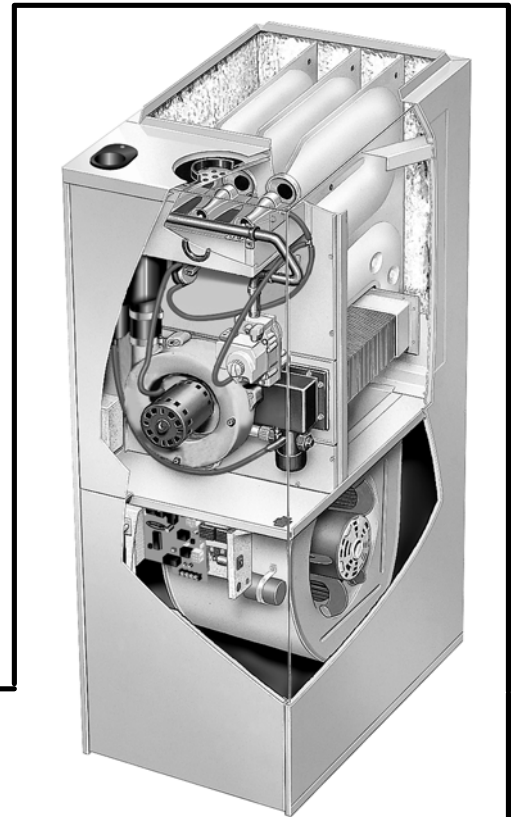


**G26 SERIES UNITS**

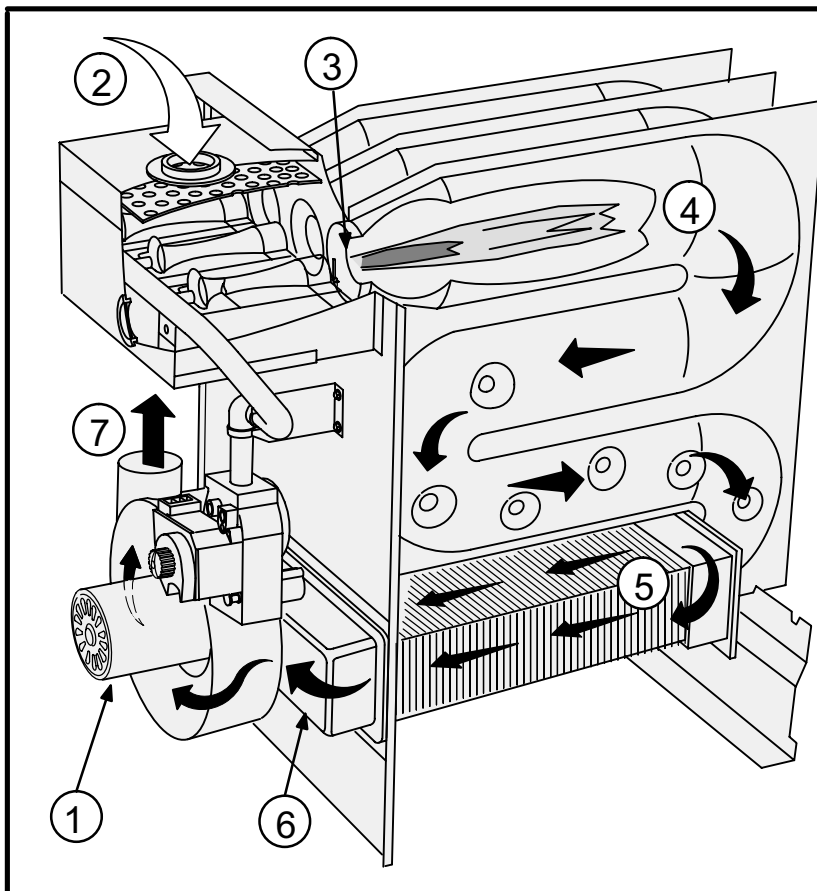
G26 series units are high-efficiency upflow gas furnaces manufactured with DuralokPlus™ aluminized steel clamshell-type heat exchangers. G26 units are available in heating capacities of 50,000 to 125,000 Btuh and cooling applications up to 5 tons. Refer to Engineering Handbook for proper sizing.

Units are factory equipped for use with natural gas. A kit is available for conversion to LPG operation. G26-1 and -2 model units use electronic (intermittent pilot) ignition. G26-3, -4, -5 and -6 model units feature the Lennox SureLight™ silicon nitride ignition system. Each unit meets the California Nitrogen Oxides (NO<sub>x</sub>) Standards and California Seasonal Efficiency requirements without modification. All units use a redundant gas valve to assure safety shut-off as required by A.G.A. or C.G.A.

Information contained in this manual is intended for use by qualified service technicians only. All specifications are subject to change. Procedures outlined in this manual are presented as a recommendation only and do not supersede or replace local or state codes. In the absence of local or state codes, the guidelines and procedures outlined in this manual (except where noted) are recommended only.



**G26 FURNACE ▲  
G26 HEAT EXCHANGE ASSEMBLY**



**Combustion Process:**

1. A call for heat starts the combustion air blower.
2. Outdoor air is drawn through pipe into the burner compartment where it mixes with gas in a conventional style inshot burner.
3. The SureLight ignition system lights the burners.
4. Combustion products are drawn downward through the heat exchanger. Heat is extracted as indoor air passes across the outside surface of the metal.
5. Latent heat is removed from the combustion products as air passes through the coil. Condensate (water) is formed as the combustion products cool.
6. As the combustion products exit the coil, condensate is collected and drained away.
7. Combustion products are pulled from the heat exchanger and forced into the flue.

## SPECIFICATIONS

Model No.		G26Q2-50	G26Q3-50	G26Q3-75	G26Q4/5-75
Input Btuh (kW)		50,000 (14.7)		75,000 (22.0)	
Output Btuh (kW)		46,000 (13.5)	47,000 (13.8)	70,000 (20.5)	69,000 (20.2)
☆A.F.U.E.		92%	92.4%	92.0%	92.0%
California Seasonal Efficiency		85.9%	86.5%	86.3%	83.8%
☐ Exhaust pipe connection (PVC) diameter— in. (mm)		2 (51)			
☐ Intake pipe connection (PVC) diameter— in. (mm)		2 (51)			
Condensate drain connection (PVC)— in. (mm)		1/2 (12.7)			
Temperature rise range — °F (°C)		40-70 (22-39)	30-60 (17-33)	40-70 (22-39)	20-50 (11-28)
High static certified by (A.G.A./C.G.A.) — in. wg. (Pa)		.50 (125)			
Gas Piping Size I.P.S. Natural or LPG/propane	in.	1/2			
	mm	12.7			
Blower wheel nominal diameter x width	in.	10 x 7	10 x 8	11-1/2 x 9	
	mm	254 x 178	254 x 203	292 x 229	
Blower motor output — hp (W)		1/5 (149)	1/3 (249)	3/4 (560)	
Nominal cooling that can be added	Tons	1 to 2	2 to 3	3-1/2 to 5	
	kW	3.5 to 7.0	3.5 to 10.6	12.3 to 17.6	
Shipping weight — lbs. (kg) 1 package		150 (68)	157 (71)	157 (71)	182 (83)
Electrical characteristics		120 volts — 60 hertz — 1 phase (all models) (less than 12 amps)			
<b>↘ Optional Accessories (Must Be Ordered Extra) ↘</b>					
LPG/Propane kit (optional)		<b>65K27</b> (all models)			
Filter and Filter Rack Kits ‡No. & size of filters - in. (mm)		Single ( <b>44J20</b> ) Ten Pack ( <b>66K61</b> ) (1) 14 x 25 x 1 (356 x 635 x 25)			Single ( <b>44J21</b> ) Ten Pack ( <b>66K62</b> ) (1) 20 x 25 x 1 (508 x 635 x 25)
Concentric Vent/Intake Air/Roof Termination Kit (optional)		<b>60G77</b> — 1 1/2 inch (38 mm)			
☐ Vent/Intake Air Roof Termination Kit (optional) — vent size	2 inch (51 mm)	<b>15F75</b>			
	3 inch (76 mm)	<b>44J41</b>			
☐ Vent/Intake Air Wall Termination Kit (optional) — vent size	2 inch (51 mm)	<b>15F74</b> (ring kit) — <b>22G44</b> (close couple) — <b>30G28</b> (WTK close couple) <b>30G79</b> (WTKX close couple with extension riser)			
	3 inch (76 mm)	<b>44J40</b> (close couple) or <b>81J20</b> (WTK close couple)			
Twinning Kits (optional)	Non-continuous low speed	<b>64H88</b> (all models)			
	Continuous low speed	<b>35J93</b> (all models)			
Continuous Low Speed Blower Switch (optional)		<b>44J06</b> (-1 and -2 models) Not used with Twinning Kits			

☆Annual Fuel Utilization Efficiency based on U.S. DOE test procedures and FTC labeling regulations. Isolated combustion system rating for non-weatherized furnaces.  
‡Polyurethane frame type filter.

☐ Determine from venting tables proper intake and exhaust pipe size and termination kit required.

## SPECIFICATIONS

Model No.	G26Q3/4-100	G26Q4/5-100	G26Q3/4-125	G26Q4/5-125	
Input Btuh (kW)	100,000 (29.3)		125,000 (36.6)		
Output Btuh (kW)	91,000 (26.7)	93,000 (27.2)	115,000 (33.7)	116,000 (34.0)	
☆A.F.U.E.	92.0%	92.0%	91.0%	92.0%	
California Seasonal Efficiency	86.6%	85.8%	87.5%	87.0%	
☐ Exhaust pipe connection (PVC) diameter— in. (mm)	2 (51)				
☐ Intake pipe connection (PVC) diameter— in. (mm)	3 (76)				
Condensate drain connection (PVC)— in. (mm)	1/2 (12.7)				
Temperature rise range — °F (°C)	50-80 (28-44)	40-70 (22-39)	55-85 (31-47)	50-80 (28-44)	
High static certified by (A.G.A./C.G.A.) — in. wg. (Pa)	.50 (125)				
Gas Piping Size I.P.S. Natural or LPG/propane	in.	1/2			
	mm	12.7			
Blower wheel nominal diameter x width	in.	10 x 10	11-1/2 x 9	10 x 10	11-1/2 x 9
	mm	254 x 254	292 x 229	254 x 254	292 x 229
Blower motor output — hp (W)	1/2 (373)	3/4 (560)	1/2 (373)	3/4 (560)	
Nominal cooling that can be added	Tons	2 to 4	3-1/2 to 5	2 to 4	3-1/2 to 5
	kW	7.0 to 14.1	12.3 to 17.6	7.0 to 14.1	12.3 to 17.6
Shipping weight — lbs. (kg) 1 package	186 (84)	198 (90)	218 (99)	218 (99)	
Electrical characteristics	120 volts — 60 hertz — 1 phase (all models) (less than 12 amps)				
<b>◆ Optional Accessories (Must Be Ordered Extra) ◆</b>					
LPG/Propane kit (optional)	<b>65K27</b> (all models)				
Filter and Filter Rack Kits ‡No. & size of filters - in. (mm)	Single <b>(44J21)</b> Ten Pack <b>(66K62)</b> (1) 20 x 25 x 1 (508 x 635 x 25)				
Concentric Vent/Intake Air/Roof Termination Kit (optional)	<b>33K97</b> — 2 inch (51 mm) 60L46 - 3 inch (76 mm)				
☐ Vent/Intake Air Roof Termination Kit (optional) — vent size	2 inch (51 mm)	<b>15F75</b>			
	3 inch (76 mm)	<b>44J41</b>			
☐ Vent/Intake Air Wall Termination Kit (optional) — vent size	2 inch (51 mm)	<b>15F74</b> (ring kit) — <b>22G44</b> (close couple) — <b>30G28</b> (WTK close couple) <b>30G79</b> (WTKX close couple with extension riser)			
	3 inch (76 mm)	<b>44J40</b> (close couple) — <b>81J20</b> (WTK close couple)			
Twinning Kits (optional)	Non-continuous low speed	<b>64H88</b> (all models)			
	Continuous low speed	<b>35J93</b> (all models)			
Continuous Low Speed Blower Switch (optional)	<b>44J06</b> (-1 and -2 models) Not used with Twinning Kits				

☆Annual Fuel Utilization Efficiency based on U.S. DOE test procedures and FTC labeling regulations. Isolated combustion system rating for non-weatherized furnaces.  
‡Polyurethane frame type filter.

☐ Determine from venting tables proper intake and exhaust pipe size and termination kit required.

NOTE - 2 inch x 3 inch (51 mm x 76 mm) adaptor is furnished with -100 and -125 furnaces for exhaust pipe connection.

**BLOWER PERFORMANCE DATA**  
**FILTER AIR RESISTANCE**

<b>cfm (L/s)</b>	<b>in. w.g. (Pa)</b>
0 (0)	0.00 (0)
200 (95)	0.01 (0)
400 (190)	0.03 (5)
600 (285)	0.04 (10)
800 (380)	0.06 (15)
1000 (470)	0.09 (20)
1200 (565)	0.12 (30)
1400 (660)	0.15 (35)
1600 (755)	0.19 (45)
1800 (850)	0.23 (55)
2000 (945)	0.27 (65)
2200 (1040)	0.33 (80)
2400 (1130)	0.38 (95)
2600 (1225)	0.44 (110)

**BLOWER PERFORMANCE DATA  
G26Q2-50 BLOWER PERFORMANCE**

External Static Pressure		Air Volume and Motor Watts at Specific Blower Taps								
		High			Medium			Low		
in. w.g.	Pa	cfm	L/s	Watts	cfm	L/s	Watts	cfm	L/s	Watts
0	0	1115	525	495	885	415	360	720	340	280
.10	25	1095	515	475	880	415	350	700	330	265
.20	50	1065	505	465	855	405	340	680	320	260
.30	75	1035	490	445	830	390	325	660	310	250
.40	100	995	470	425	755	355	315	645	305	235
.50	125	950	450	405	755	355	300	625	295	225
.60	150	900	425	390	740	350	280	540	255	215
.70	175	815	385	365	660	310	255	530	250	205
.80	200	610	290	340	585	275	240	360	170	180
.90	225	590	280	315	390	185	215	----	----	----

NOTE — All air data is measured external to unit with 1 in. (25 mm) cleanable foam filter (not furnished) in place. Also see Filter Air Resistance table.

**G26Q3-50 BLOWER PERFORMANCE**

External Static Pressure		Air Volume and Motor Watts at Specific Blower Taps											
		High			Medium-High			Medium-Low			Low		
in. w.g.	Pa	cfm	L/s	Watts	cfm	L/s	Watts	cfm	L/s	Watts	cfm	L/s	Watts
0	0	1485	700	590	1275	600	485	1045	495	390	840	395	310
.10	25	1445	680	565	1250	590	460	1030	485	375	830	390	300
.20	50	1390	655	545	1225	580	445	1010	475	365	815	385	290
.30	75	1345	635	520	1190	560	425	985	465	345	790	375	285
.40	100	1290	610	500	1150	545	405	955	450	335	780	370	275
.50	125	1225	580	480	1095	515	385	920	435	315	735	345	255
.60	150	1160	545	460	1030	485	365	875	415	300	700	330	240
.70	175	1075	505	440	950	450	345	855	405	280	600	285	220
.80	200	975	460	415	865	410	315	645	305	250	510	240	195
.90	225	845	400	385	615	290	265	545	255	225	375	175	180

NOTE — All air data is measured external to unit with 1 in. (25 mm) cleanable foam filter (not furnished) in place. Also see Filter Air Resistance table.

**G26Q3-75 BLOWER PERFORMANCE**

External Static Pressure		Air Volume and Motor Watts at Specific Blower Taps											
		High			Medium-High			Medium-Low			Low		
in. w.g.	Pa	cfm	L/s	Watts	cfm	L/s	Watts	cfm	L/s	Watts	cfm	L/s	Watts
0	0	1490	705	650	1340	630	540	1060	500	440	870	410	360
.10	25	1435	675	625	1305	615	515	1050	495	425	865	410	350
.20	50	1385	655	605	1260	595	490	1025	485	405	850	400	335
.30	75	1330	630	580	1215	575	470	1000	470	385	835	395	325
.40	100	1260	595	560	1160	545	445	965	455	365	810	380	310
.50	125	1200	565	540	1100	520	420	920	435	345	770	365	290
.60	150	1125	530	515	1035	490	400	870	410	325	735	345	280
.70	175	1035	490	495	960	455	375	780	370	305	685	325	265
.80	200	935	440	475	865	410	345	725	340	285	----	----	----
.90	225	805	380	445	630	295	295	540	255	240	----	----	----

NOTE — All air data is measured external to unit with 1 in. (25 mm) cleanable foam filter (not furnished) in place. Also see Filter Air Resistance table.

**G26Q4/5-75 BLOWER PERFORMANCE**

External Static Pressure		Air Volume and Motor Watts at Specific Blower Taps														
		High			Medium-High			Medium			Medium-Low			Low		
in. w.g.	Pa	cfm	L/s	Watts	cfm	L/s	Watts	cfm	L/s	Watts	cfm	L/s	Watts	cfm	L/s	Watts
0	0	2415	1140	1240	2120	1000	1015	1875	885	855	1635	770	705	1430	675	585
.10	25	2330	1100	1200	2090	985	1005	1835	865	835	1615	760	700	1420	670	585
.20	50	2265	1070	1165	2045	965	990	1795	845	815	1580	745	690	1390	655	580
.30	75	2210	1045	1145	2000	945	970	1765	835	810	1545	730	675	1365	645	575
.40	100	2145	1010	1110	1950	920	955	1720	810	795	1510	715	670	1340	630	570
.50	125	2075	980	1085	1885	890	930	1680	795	785	1475	695	665	1310	620	565
.60	150	2000	945	1060	1825	860	910	1630	770	770	1435	675	655	1270	600	555
.70	175	1935	915	1040	1775	840	895	1565	740	755	1395	660	645	1220	575	545
.80	200	1840	870	1005	1705	805	870	1515	715	745	1345	635	630	1165	550	535
.90	225	1760	830	980	1610	760	845	1455	685	725	1275	600	615	1110	525	530

NOTE — All air data is measured external to unit with 1 in. (25 mm) cleanable foam filter (not furnished) in place. Also see Filter Air Resistance table.

**BLOWER PERFORMANCE DATA**  
**G26Q3/4-100 BLOWER PERFORMANCE**

External Static Pressure		Air Volume and Motor Watts at Specific Blower Taps											
		High			Medium-High			Medium-Low			Low		
in. w.g.	Pa	cfm	L/s	Watts	cfm	L/s	Watts	cfm	L/s	Watts	cfm	L/s	Watts
0	0	2065	975	920	1760	830	735	1570	740	655	1245	590	520
.10	25	2000	945	875	1730	815	705	1550	730	625	1240	585	490
.20	50	1925	910	845	1685	795	675	1515	715	590	1225	580	470
.30	75	1840	870	800	1625	765	630	1475	695	565	1210	570	455
.40	100	1740	820	760	1550	730	595	1415	670	535	1165	550	430
.50	125	1650	780	730	1460	690	560	1335	630	500	1110	525	405
.60	150	1545	730	700	1370	645	530	1260	595	475	1045	495	385
.70	175	1420	670	660	1250	590	495	1170	550	445	950	450	355
.80	200	1270	600	620	1110	525	445	1025	485	395	825	390	325
.90	225	1045	495	560	965	455	405	885	420	360	700	330	290

NOTE — All air data is measured external to unit with 1 in. (25 mm) cleanable foam filter (not furnished) in place. Also see Filter Air Resistance table.

**G26Q4/5-100 BLOWER PERFORMANCE**

External Static Pressure		Air Volume and Motor Watts at Specific Blower Taps														
		High			Medium-High			Medium			Medium-Low			Low		
in. w.g.	Pa	cfm	L/s	Watts	cfm	L/s	Watts	cfm	L/s	Watts	cfm	L/s	Watts	cfm	L/s	Watts
0	0	2400	1135	1255	2185	1030	1070	1940	915	905	1740	820	765	1570	740	665
.10	25	2350	1110	1230	2150	1015	1055	1920	905	885	1710	805	755	1525	720	645
.20	50	2290	1080	1185	2105	995	1025	1875	885	865	1685	795	740	1505	710	640
.30	75	2225	1050	1170	2060	970	1005	1845	870	850	1655	780	730	1485	700	630
.40	100	2165	1020	1130	2010	950	985	1805	850	835	1620	765	720	1450	685	620
.50	125	2105	995	1115	1950	920	960	1755	830	810	1585	750	700	1415	670	605
.60	150	2040	965	1080	1895	895	940	1700	800	790	1540	725	690	1380	650	595
.70	175	1955	925	1045	1820	860	915	1640	775	775	1475	695	670	1340	630	590
.80	200	1850	875	1005	1730	815	885	1580	745	755	1430	675	660	1290	610	580
.90	225	1770	835	985	1650	780	855	1505	710	740	1370	645	645	1225	580	565

NOTE — All air data is measured external to unit with 1 in. (25 mm) cleanable foam filter (not furnished) in place. Also see Filter Air Resistance table.

**G26Q3/4-125 BLOWER PERFORMANCE**

External Static Pressure		Air Volume and Motor Watts at Specific Blower Taps											
		High			Medium-High			Medium-Low			Low		
in. w.g.	Pa	cfm	L/s	Watts	cfm	L/s	Watts	cfm	L/s	Watts	cfm	L/s	Watts
0	0	2070	975	920	1735	820	725	1555	735	640	1235	585	500
.10	25	2010	950	885	1710	805	700	1535	725	625	1225	580	490
.20	50	1950	920	850	1675	790	680	1500	710	600	1210	570	470
.30	75	1975	930	820	1620	765	645	1465	690	575	1185	560	455
.40	100	1785	840	775	1560	735	615	1415	670	545	1140	540	435
.50	125	1700	800	745	1475	695	575	1345	635	520	1090	515	415
.60	150	1585	750	705	1410	665	555	1275	600	490	1035	490	390
.70	175	1475	695	675	1310	620	515	1185	560	460	975	460	370
.80	200	1350	635	640	1200	565	485	1090	515	425	865	410	340
.90	225	1200	565	595	1080	510	445	965	455	385	715	335	300

NOTE — All air data is measured external to unit with 1 in. (25 mm) cleanable foam filter (not furnished) in place. Also see Filter Air Resistance table.

**G26Q4/5-125 BLOWER PERFORMANCE**

External Static Pressure		Air Volume and Motor Watts at Specific Blower Taps														
		High			Medium-High			Medium			Medium-Low			Low		
in. w.g.	Pa	cfm	L/s	Watts	cfm	L/s	Watts	cfm	L/s	Watts	cfm	L/s	Watts	cfm	L/s	Watts
0	0	2400	1135	1210	2175	1025	1040	1965	925	895	1790	845	780	1610	760	670
.10	25	2315	1090	1175	2125	1005	1025	1930	910	875	1760	830	770	1580	745	660
.20	50	2255	1065	1150	2080	980	1000	1880	885	860	1740	820	755	1550	730	645
.30	75	2195	1035	1130	2030	960	975	1840	870	835	1710	805	750	1520	715	635
.40	100	2120	1000	1100	1970	930	960	1790	845	815	1665	785	730	1495	705	630
.50	125	2050	965	1080	1910	900	934	1745	825	800	1620	765	715	1460	690	620
.60	150	1985	935	1050	1840	870	905	1685	795	785	1565	740	705	1415	670	610
.70	175	1885	890	1020	1770	835	890	1635	765	775	1515	715	685	1370	645	595
.80	200	1815	855	1005	1690	800	860	1570	740	750	1450	685	670	1315	620	580
.90	225	1735	820	980	1615	760	835	1485	700	725	1385	655	655	1245	590	565

NOTE — All air data is measured external to unit with 1 in. (25 mm) cleanable foam filter (not furnished) in place. Also see Filter Air Resistance table.

## INTAKE and EXHAUST PIPE VENTING TABLE

Vent Pipe Maximum Equivalent Length		Minimum Vent Pipe Diameter Required							
		50,000 Btuh (14.7 kW)		75,000 Btuh (22.0 kW)		100,000 Btuh (29.3 kW)		125,000 Btuh (36.6 kW)	
Feet	Meters	in.	mm	in.	mm	in.	mm	in.	mm
15	4.6	1-1/2	38	2	51	2	51	2	51
20	6.1	2	51	2	51	2	51	3	76
25	7.6	2	51	2	51	2	51	3	76
30	9.1	2	51	2	51	3	51	3	76
40	12.2	2	51	2	51	3	51	3	76
50	15.2	2	51	2	51	3	51	3	76
55	16.8	2	51	2	51	3	76	3	76
60	18.3	3	76	3	76	3	76	3	76
70	21.3	3	76	3	76	3	76	3	76
80	24.4	3	76	3	76	3	76	3	76
90	27.4	3	76	3	76	3	76	3	76
100	30.5	3	76	3	76	3	76	3	76
110	33.5	3	76	3	76	3	76	3	76
120	36.6	3	76	3	76	3	76	3	76
130	39.6	3	76	3	76	3	76	---	---

MINIMUM PIPE LENGTHS FOR FURNACES — **G26-50** — 5 feet (1.5 m) with two 90° elbows of 1-1/2 inch (38 mm) diameter pipe. (15 equivalent feet (4.6 m) total).  
**G26-75** — 5 feet (1.5 m) with two 90° elbows of 2 inch (51 mm) diameter pipe. (15 equivalent feet (4.6 m) total).  
**G26-100** — 5 feet (1.5 m) with two 90° elbows of 2 inch (51 mm) diameter pipe. (15 equivalent feet (4.6 m) total).  
**G26-125** — 5 feet (1.5 m) with two 90° elbows of 2 inch (51 mm) diameter pipe. (15 equivalent feet (4.6 m) total).

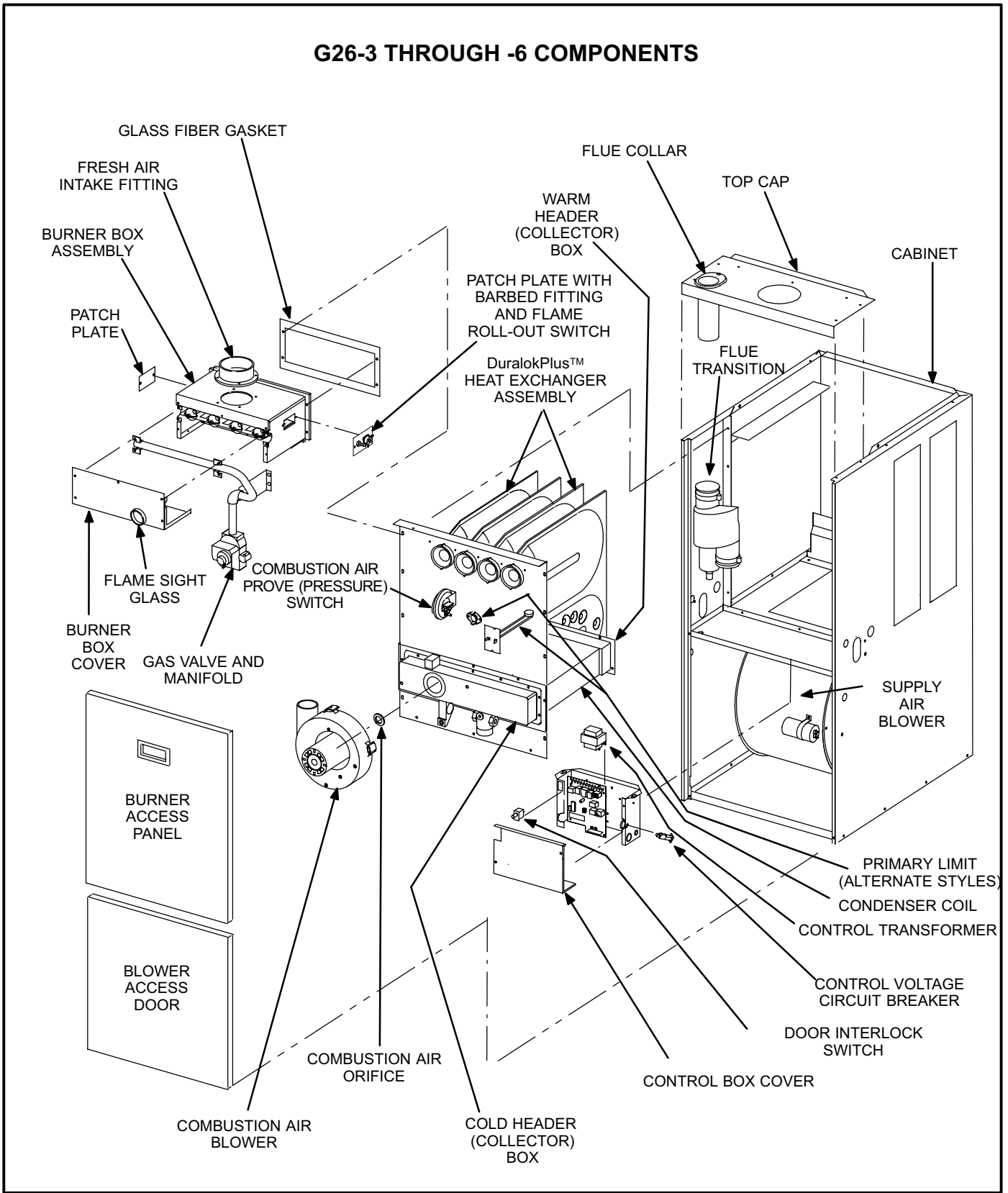
VENTING NOTES — One 90° elbow is equivalent to 5 feet (1.5 m) of straight vent pipe.  
 Two 45° elbows are equal to one 90° elbow.  
 One 45° elbow is equivalent to 2.5 feet (.75 m) of straight vent pipe.  
 One foot (305 mm) length of 2 in. (51 mm) diameter pipe is equivalent to 8 feet (2.4 m) of 3 in. (76 mm) diameter pipe.  
 Intake and Exhaust pipes must be the same diameter.  
 2 inch x 3 inch (51 mm x 76 mm) adaptor is furnished with -100 and -125 furnaces for exhaust pipe connection.  
 Exhaust pipe must terminate with 1-1/2 inch (38 mm) diameter pipe for furnaces using 1-1/2 (38 mm) or 2 inch (51 mm) diameter pipe runs.  
 Exhaust pipe must terminate with 2 inch (51 mm) diameter pipe for furnaces using 3 inch (76 mm) diameter pipe runs.  
 See pages 10 thru 12 for Termination Kits available.

## GAS PIPE CAPACITY - FT<sup>3</sup>/HR (KL/HR)

Nominal Iron Pipe Size -Inches(mm)	Internal Diameter -Inches(mm)	Length of Pipe-Feet(m)									
		10 (3.048)	20 (6.096)	30 (9.144)	40 (12.192)	50 (15.240)	60 (18.288)	70 (21.336)	80 (24.384)	90 (27.432)	100 (30.480)
1/4 (6.35)	.364 (9.246)	43 (1.13)	29 (.82)	24 (.68)	20 (.57)	18 (.51)	16 (.45)	15 (.42)	14 (.40)	13 (.37)	12 (.34)
3/8 (9.53)	.493 (12.522)	95 (2.69)	65 (1.84)	52 (1.47)	45 (1.27)	40 (1.13)	36 (1.02)	33 (.73)	31 (.88)	29 (.82)	27 (.76)
1/2 (12.7)	.622 (17.799)	175 (4.96)	120 (3.40)	97 (2.75)	82 (2.32)	73 (2.07)	66 (1.87)	61 (1.73)	57 (1.61)	53 (1.50)	50 (1.42)
3/4 (19.05)	.824 (20.930)	360 (10.19)	250 (7.08)	200 (5.66)	170 (4.81)	151 (4.28)	138 (3.91)	125 (3.54)	118 (3.34)	110 (3.11)	103 (2.92)
1 (25.4)	1.049 (26.645)	680 (19.25)	465 (13.17)	375 (10.62)	320 (9.06)	285 (8.07)	260 (7.36)	240 (6.80)	220 (6.23)	205 (5.80)	195 (5.52)
1-1/4 (31.75)	1.380 (35.052)	1400 (39.64)	950 (26.90)	770 (21.80)	660 (18.69)	580 (16.42)	530 (15.01)	490 (13.87)	460 (13.03)	430 (12.18)	400 (11.33)
1-1/2 (38.1)	1.610 (40.894)	2100 (59.46)	1460 (41.34)	1180 (33.41)	990 (28.03)	900 (25.48)	810 (22.94)	750 (21.24)	690 (19.54)	650 (18.41)	620 (17.56)
2 (50.8)	2.067 (52.502)	3950 (111.85)	2750 (77.87)	2200 (62.30)	1900 (53.80)	1680 (47.57)	1520 (43.04)	1400 (39.64)	1300 (36.81)	1220 (34.55)	1150 (32.56)
2-1/2 (63.5)	2.469 (62.713)	6300 (178.39)	4350 (123.17)	3520 (99.67)	3000 (84.95)	2650 (75.04)	2400 (67.96)	2250 (63.71)	2050 (58.05)	1950 (55.22)	1850 (52.38)
3 (76.2)	3.068 (77.927)	11000 (311.48)	7700 (218.03)	6250 (176.98)	5300 (150.07)	4750 (134.50)	4300 (121.76)	3900 (110.43)	3700 (104.77)	3450 (97.69)	3250 (92.03)
4 (101.6)	4.026 (102.260)	23000 (651.27)	15800 (447.39)	12800 (362.44)	10900 (308.64)	9700 (274.67)	8800 (249.18)	8100 (229.36)	7500 (212.37)	7200 (203.88)	6700 (189.72)

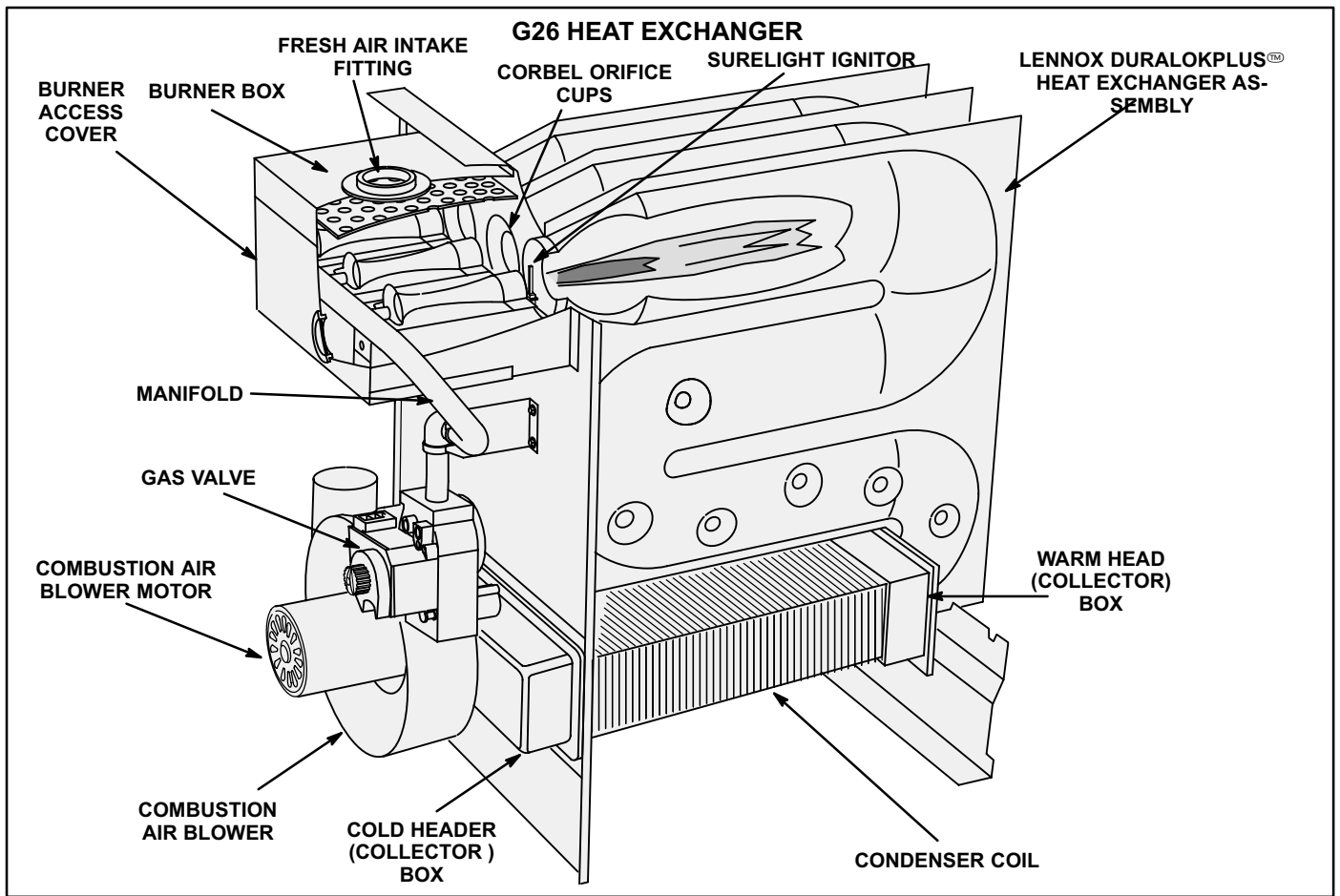
NOTE-Capacity given in cubic feet of gas per hour (kilo liters of gas per hour) and based on 0.60 specific gravity gas.

## G26-3 THROUGH -6 COMPONENTS

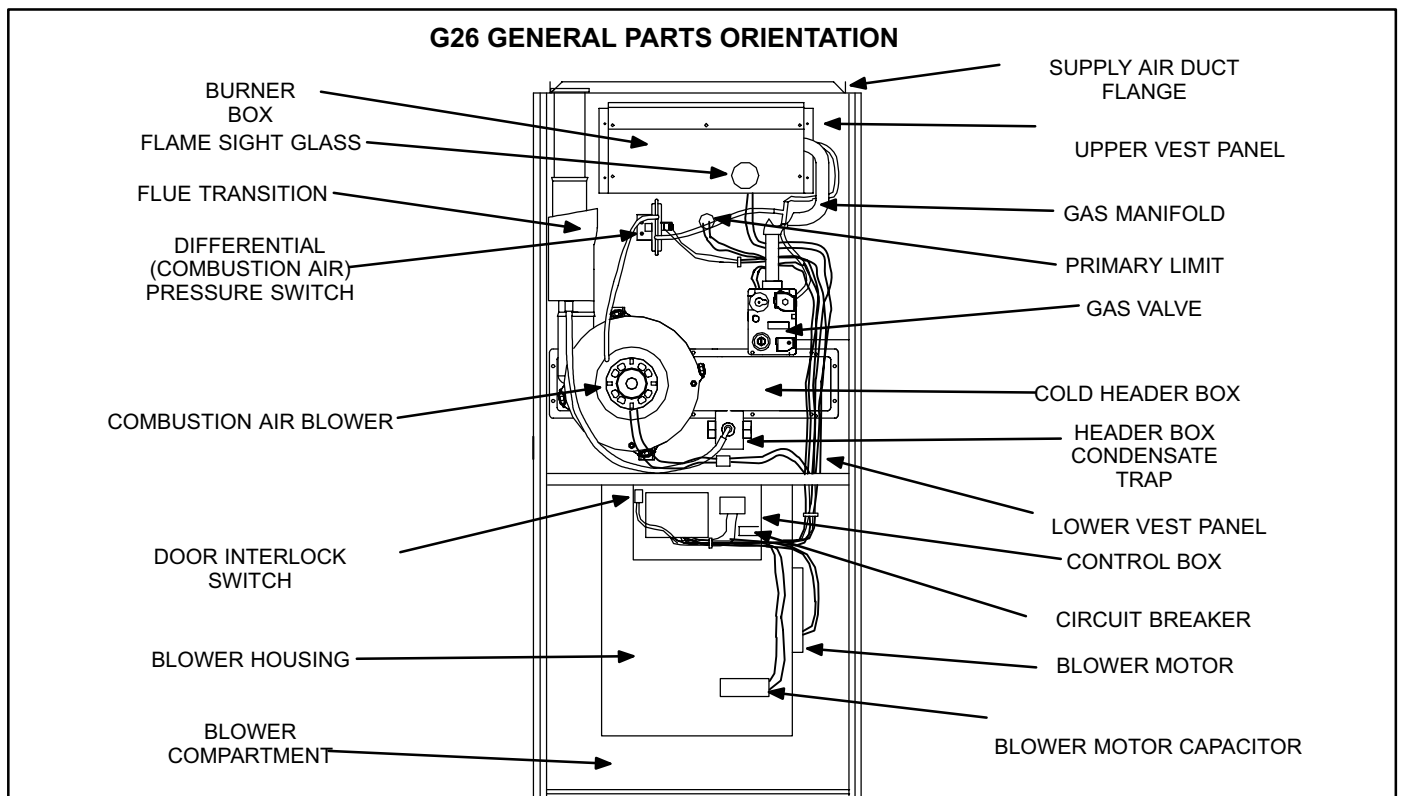


**FIGURE 1**

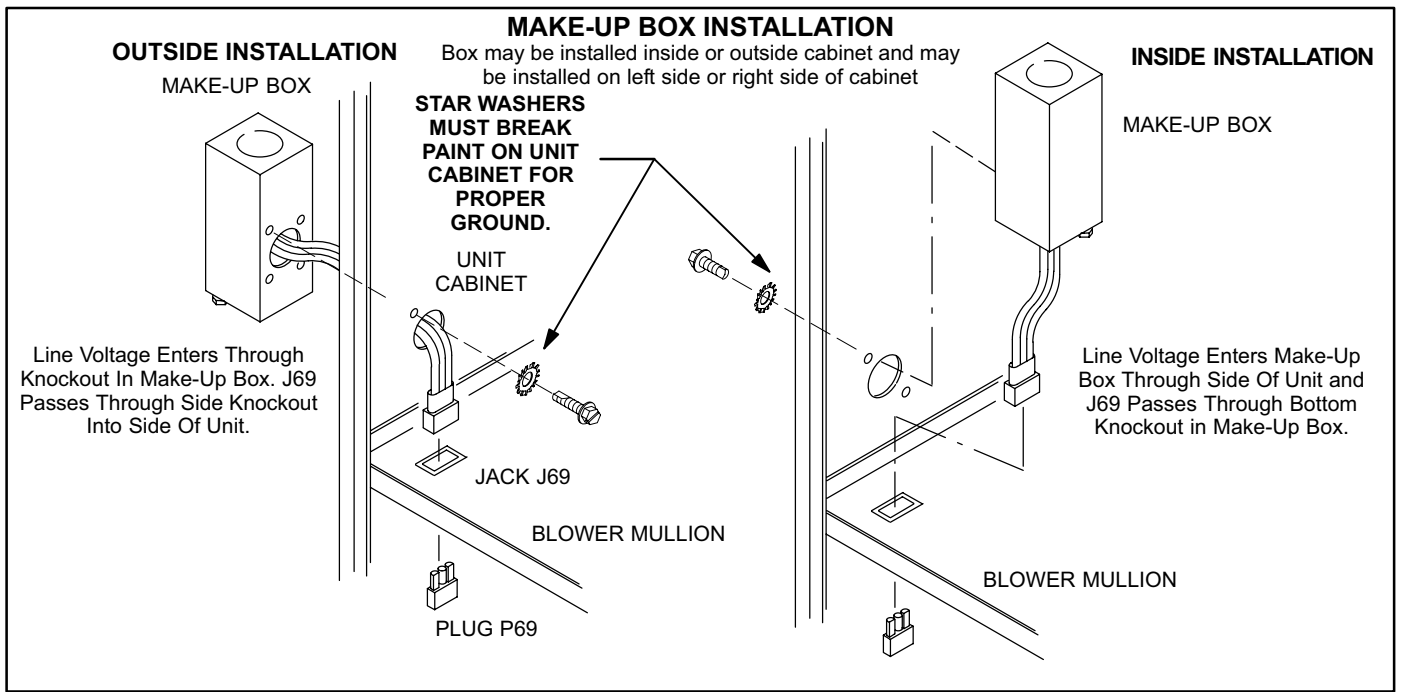




**FIGURE 2**



**FIGURE 3**



**FIGURE 4**

**I-UNIT COMPONENTS**

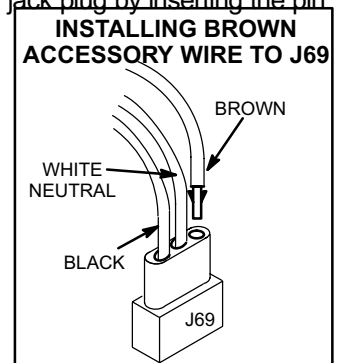
G26 unit components are shown in figure 1. General parts orientation is shown in figure 3. The gas valve, ignition control and burners can be accessed by removing the burner access panel. The blower and blower controls can be accessed by removing the blower access door.

G26 units are designed for bottom and side return air. The panels are designed to be knocked-out (bottom return) or cut-out (side return) as required for return air duct connection.

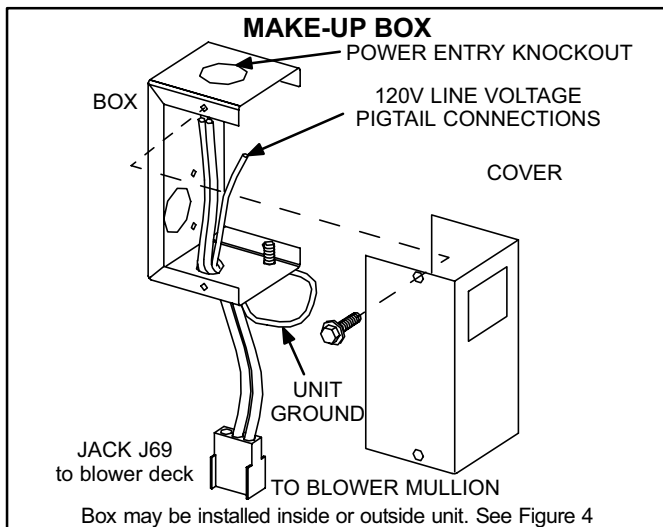
**A-Make-Up Box (Figure 5)**

The line voltage make-up box is shown in figure 5. The box may be installed inside or outside the unit and may be installed on the unit left or right side (figure 4).

An accessory (brown) output wire is provided with the make-up box. The wire provides a 120V connection for optional accessories such as electronic air cleaner or humidifier. If used, the wire is field installed in J69 jack plug by inserting the pin of the brown wire into the open socket of the jack. See figure 6. 120V accessories rated up to 4 amps total may be connected to this wire. The neutral leg of the accessory is connected to the neutral white wire in the make-up box. The accessory terminal is energized whenever the blower is in operation.

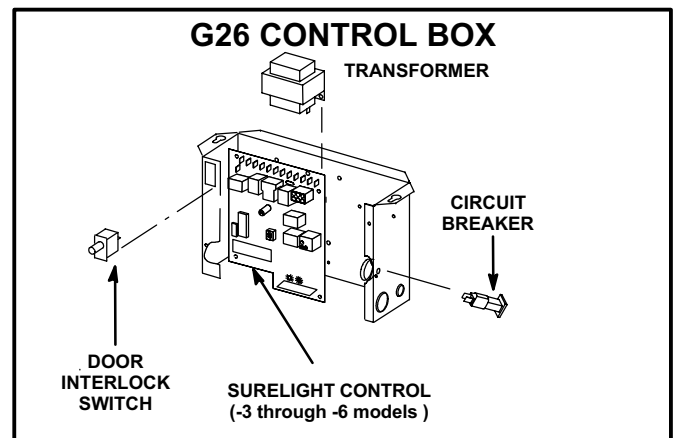


**FIGURE 6**



**FIGURE 5**

**B-Control Box Components**



**FIGURE 7**

Electrical blower control components (A15), unit transformer (T1) and 24V circuit breaker (CB8) are located in the control box. In addition, a door interlock switch (S51) is located in the control box. Jackplugs and a “snap-off” terminal strip allow the control box to be easily removed for blower service.

### 1- Control Transformer (T1)

A transformer located in the control box provides power to the low voltage 24volt section of the unit. Transformers on all models are rated 40VA with a 120V primary and a 24V secondary.

### 2- Circuit Breaker (CB8)

A 24V circuit breaker is also located in the control box. The switch provides overcurrent protection to the transformer (T1). The breaker is rated 3A at 32V. If the current exceeds this limit the breaker will trip and all unit operation will shut-down. The breaker can be manually reset by pressing the button on the face.

### 3-Door Interlock Switch (S51)

A door interlock switch rated 14A at 125VAC is located on the control box. The switch is wired in series with line voltage. When the blower door is removed the unit will shut down.

### 4-Flame Sensor (-3 through -6 models)

A flame sensor is located on the left side of the burner support. See figure 8. The sensor is mounted on a bracket in the burner support and the tip protrudes into the flame envelope of the left-most burner. The sensor is fastened to burner supports and can be removed for service without removing any part of the burners. During operation, flame is sensed by current passed through the flame and sensing electrode. The SureLight control allows the gas valve to remain open as long as flame signal is sensed.

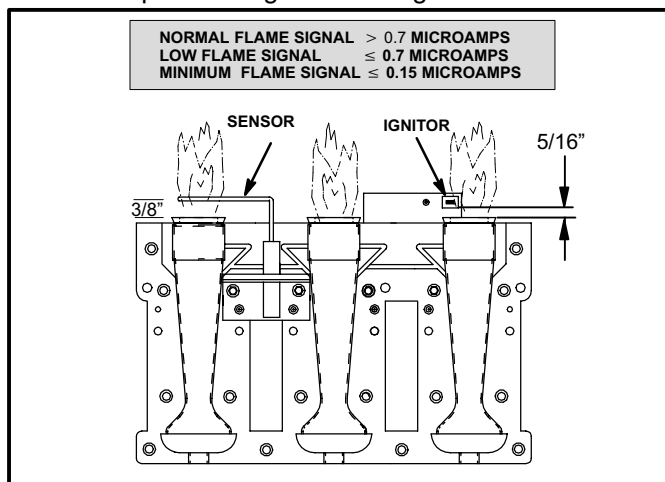


FIGURE 8

*NOTE - The G26 furnace contains electronic components that are polarity sensitive. Make sure that the furnace is wired correctly and is properly grounded.*

## 5-Burners

All units use inshot burners (see figure 9). Burners are factory set and do not require adjustment. A sight glass is furnished in the burner box assembly for flame viewing. Always operate the unit with the burner box cover in place. Burners can be removed as an assembly for service. Burner maintenance and service is detailed in the MAINTENANCE section of this manual. Each burner uses an orifice which is precisely matched to the burner input (see nameplate for orifice size). The orifice is threaded into the burner manifold. The burner is supported by the orifice and will easily slide off for service. Each orifice and burner are sized specifically to the unit. Refer to Lennox Repair Parts Listing for correct sizing information. A flame retention ring in the end of each burner maintains correct flame length and shape and keeps the flame from lifting off the burner head. In addition, the burner entrance to each clamshell (Figure 2) is fitted with a corbel cup (orifice) used to direct the flow of combustion products.

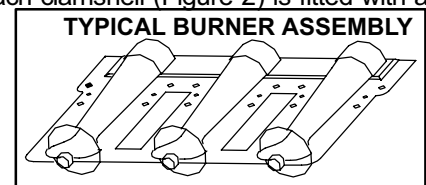


FIGURE 9

## ⚠ DANGER

**Shock hazard.**

**Disconnect power before servicing. Control is not field repairable. If control is inoperable, simply replace entire control.**

**Can cause injury or death. Unsafe operation will result if repair is attempted.**

### 6- SureLight Ignition System A3 (-3 through -6 models)

All G26-3 through -6 model units are equipped with the Lennox Sure - Light ignition system. The system consists of ignition control board (figure 10 with control terminal designations in table 1) and ignitor (figures 8 and 11). The board and ignitor work in combination to ensure furnace ignition and ignitor durability. The SureLight integrated board controls all major furnace operations. The board also features two LED lights for troubleshooting and two accessory terminals rated at (4) four amps. See table 2 for troubleshooting diagnostic codes. Table 3 and 4 show jack plug terminal designations. Units equipped with the SureLight board can be used with either electronic or electro-mechanical thermostats without modification. The SureLight ignitor is made of durable silicon-nitride. Ignitor longevity is also enhanced by voltage ramping by the control board. The board finds the lowest ignitor temperature which will successfully light the burner, thus increasing the life of the ignitor.

*NOTE - Do not remove blower access panel to read SureLight LED lights. A sight glass is provided on the access panel for viewing.*

## SURELIGHT CONTROL BOARD

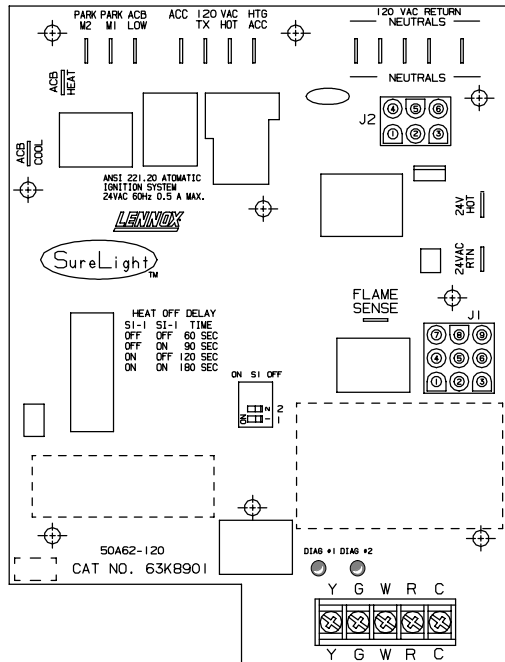


FIGURE 10

TABLE 1

SURELIGHT CONTROL TERMINAL DESIGNATIONS	
ACB COOL	Blower - Cooling Speed (Line Volt)
ACB HEAT	Blower - Heating Speed (Line Volt)
PARK	Alternate Blower Speeds (Dead)
ACB LOW	Continuous Low Speed Blower
ACC	Accessory Terminal (Line Volt)
TX	120VAC Hot to Transformer
HOT	120VAC Hot Input
HTG ACC	Heat Only Accessory (Line Volt)
NEUTRALS	120VAC Neutrals
24VAC HOT	24VAC Hot from Transformer
24VAC RTN	24VAC Return from Transformer
FLAME SENSE	Flame Sense Terminal

## SURELIGHT IGNITOR

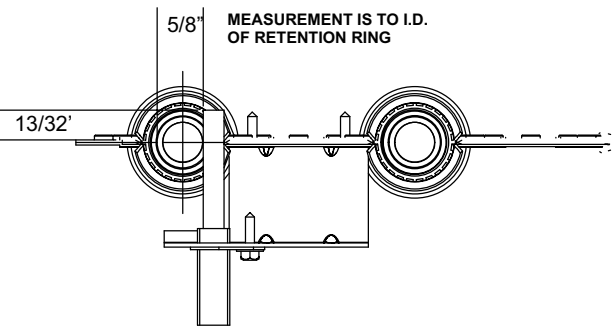


FIGURE 11

TABLE 2

## DIAGNOSTIC CODES

MAKE SURE TO ID LED'S CORRECTLY: REFER TO INSTALLATION INSTRUCTIONS FOR CONTROL BOARD LAYOUT.

LED #1	LED #2	DESCRIPTION
SIMULTANEOUS SLOW FLASH	SIMULTANEOUS SLOW FLASH	Power - Normal operation Also signaled during cooling and continues fan.
SIMULTANEOUS FAST FLASH	SIMULTANEOUS FAST FLASH	Normal operation - signaled when heating demand initiated at thermostat.
SLOW FLASH	ON	Primary or Secondary limit open. Units with board 63K8901 or 24L85: Limit must close within 5 trials for ignition or board goes into one hour limit Watchguard. Units with board 56L83 or 97L48: Limit must close within 3 minutes or board goes into one hour limit Watchguard.
OFF	SLOW FLASH	Pressure switch open or has opened 5 times during a single call for heat; OR: Blocked inlet/exhaust vent; OR: Condensate line blocked; OR: Pressure switch closed prior to activation of combustion air blower.
ALTERNATING SLOW FLASH	ALTERNATING SLOW FLASH	Watchguard - burners fail to ignite.
SLOW FLASH	OFF	Flame sensed without gas valve energized.
ON	SLOW FLASH	Rollout switch open. OR: 9 pin connector improperly attached.
ON ON OFF	ON OFF ON	Circuit board failure or control wired incorrectly.
FAST FLASH	SLOW FLASH	Main power polarity reversed. Switch line and neutral.
SLOW FLASH	FAST FLASH	Low flame signal. Measures below .7 microAmps. Replace flame sense rod.
ALTERNATING FAST FLASH	ALTERNATING FAST FLASH	Improper main ground or line voltage below 75 volts; OR: Broken ignitor; OR: Open ignitor circuit.

NOTE - Slow flash equals 1 Hz (one flash per second). Fast flash equals 3 Hz (three flashes per second). Drop out flame sense current < 0.15 microAmps

**TABLE 3**

SureLight BOARD J156 (J2) TERMINAL DESIGNATIONS	
PIN #	FUNCTION
1	Ignitor
2	Not Used
3	Ignitor Neutral
4	Combustion Air Blower Line Voltage
5	Not Used
6	Combustion Air Blower Neutral

**TABLE 4**

SureLight BOARD J58 (J1) TERMINAL DESIGNATIONS	
PIN #	FUNCTION
1	Primary Limit In
2	Gas Valve Common
3	Roll Out Switch Out
4	Gas Valve 24V
5	Pressure Switch In
6	Pressure Switch and Primary Limit Out
7	Not Used
8	Roll Out Switch In
9	Ground

**ELECTROSTATIC DISCHARGE (ESD)  
Precautions and Procedures**

**⚠ CAUTION**

Electrostatic discharge can affect electronic components. Take precautions during furnace installation and service to protect the furnace's electronic controls. Precautions will help to avoid control exposure to electrostatic discharge by putting the furnace, the control and the technician at the same electrostatic potential. Neutralize electrostatic charge by touching hand and all tools on an unpainted unit surface, such as the gas valve or blower deck, before performing any service procedure.

**a-Electronic Ignition**

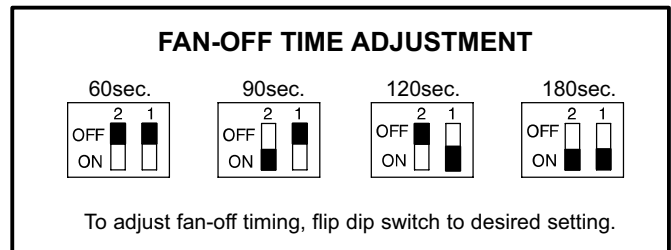
On a call for heat the SureLight control monitors the combustion air blower pressure switch. The control will not begin the heating cycle if the pressure switch is closed (bypassed). Once the pressure switch is determined to be open, the combustion air blower is energized. When the differential in the pressure switch is great enough, the

pressure switch closes and a 15-second pre-purge begins. If the pressure switch is not proven within 2-1/2 minutes, the control goes into Watchguard-Pressure Switch mode for a 5-minute re-set period.

After the 15-second pre-purge period, the SureLight ignitor warms up for 20 seconds after which the gas valve opens for a 4-second trial for ignition. G26 units with board 63K89, 24L85 or 56L83: the ignitor stays energized for the first second of the 4-second trial. Units with board 97L48: ignitor stays energized for the full 4-second ignition trial. If ignition is not proved during the 4-second period, the control will try four more times with an inter purge and warm-up time between trials of 35 seconds. After a total of five trials for ignition (including the initial trial), the control goes into Watchguard-Flame Failure mode. After a 60-minute reset period, the control will begin the ignition sequence again. The SureLight control board has an added feature that prolongs the life of the ignitor. After a successful ignition, the SureLight control utilizes less power to energize the ignitor on successive calls for heat. The control continues to ramp down the voltage to the ignitor until it finds the lowest amount of power that will provide a successful ignition. This amount of power is used for 255 cycles. On the 256th call for heat, the control will again ramp down until the lowest power is determined and the cycle begins again.

**b-Fan Time Control**

The fan on time of 45 seconds is not adjustable. Fan off time (time that the blower operates after the heat demand has been satisfied) can be adjusted by flipping the dip switches located on the SureLight integrated control. The unit is shipped with a factory fan off setting of 90 seconds. Fan off time will affect comfort and is adjustable to satisfy individual applications. See figure 12.



**FIGURE 12**

**7-Blower Motors and Capacitors**

All G26 units use direct drive blower motors. All motors used are 120V permanent split capacitor motors to ensure maximum efficiency. See table 5 for ratings.

**TABLE 5**

G26 BLOWER RATINGS 120V 1PH		
BLOWER MOTOR	HP	CAP
G26Q2	1/5	5MFD 370V
G26Q3	1/3	5MFD 370V
G26Q3/4	1/2	7.5MFD 370V
G26Q4/5	3/4	40MFD 370V

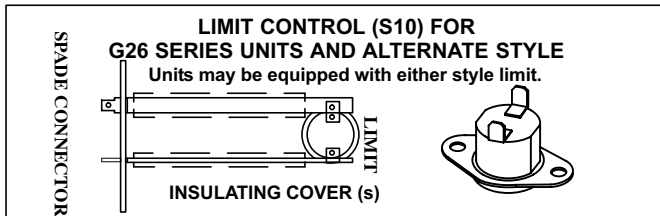
**8-Combustion Air Blower (B6)**

All G26 units use a combustion air blower to move air through the burners and heat exchanger during heating operation. The blower uses a PSC or shaded Pole 120VAC motor. PSC motors use run capacitors. The motor operates during all heating operation and is controlled by blower control A15. The blower operates continuously while there is a call for heat. The ignition control is prevented from proceeding through the ignition sequence until combustion air blower operation is sensed by the prove switch.

The pressure switch connected to the combustion air blower housing is used to prove combustion air blower operation. The switch monitors air pressure in the blower housing. During normal operation, the pressure in the housing is negative. If the pressure drops (becomes more positive), the pressure switch opens. When the pressure switch opens, the ignition control (A3) immediately closes the gas valve to prevent burner operation.

**9-Primary Limit Control (S10)**

The primary limit (S10) on G26 units is located in the middle of the heating vestibule panel. When excess heat is sensed in the heat exchanger, the limit will open. If the limit is tripped, the furnace control energizes the supply air blower and de-energizes the gas valve. The limit automatically resets when unit temperature returns to normal. The switch is factory set and cannot be adjusted. The switch may have a different setpoint for each unit model number. However, the setpoint will be printed on the side of the limit.

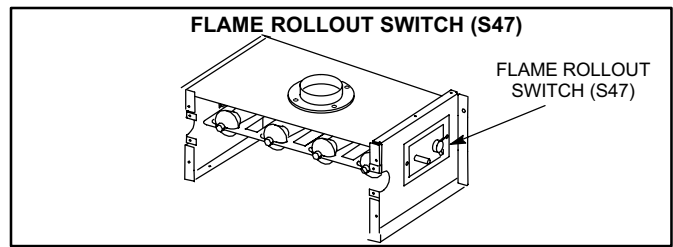


**FIGURE 13**

**10-Rollout Switch (S47) -3 Through -6**

Flame rollout switch S47 is a SPST N.C. high temperature limit located on the right side of the burner box assembly (see figure 14). S47 is wired to the burner ignition control A3. When S47 senses flame rollout (indicating a blockage in the combustion passages), the flame rollout switch trips, and the ignition control immediately closes the gas valve.

Switch S47 in all G26 units is factory preset to open at 200°F ± 12°F (93°C ± 6.7°C) on a temperature rise. All flame rollout switches are manually reset. A kit (#65K60) is available for G26 -1 and -2 models.



**FIGURE 14**

**11- BCC2-3 Blower Control A15 (-1 and -2 models)**

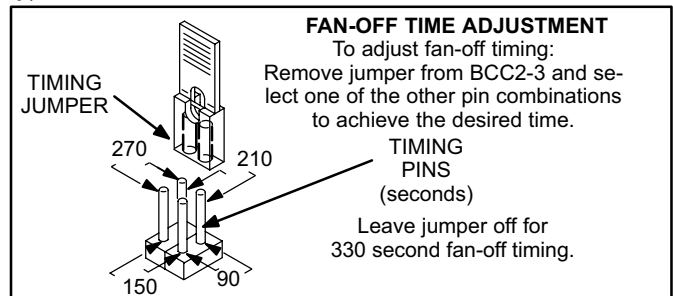
All G26-2 and -1 model units utilize the BCC2-3 blower control manufactured by Heatcraft. The BCC2-3 is a printed circuit board which controls the supply air blower and monitors primary limit and gas valve operation. The control has a non-adjustable, factory preset “fan-on” timing. Fan “off” timing is adjustable. The board is divided into two sections, 120 and 24VAC. Line voltage comes into the board on the 120VAC side. See figure 16.

**Fan Timings**

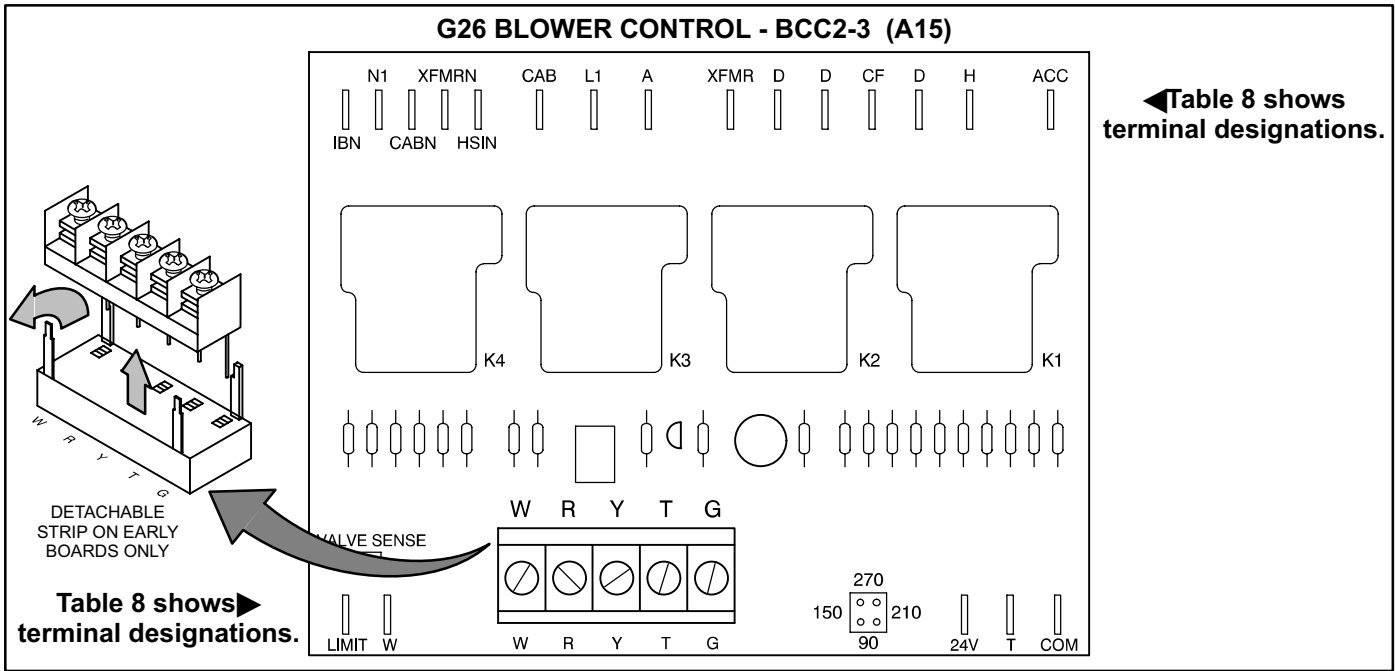
Fan “off” timing (time that the blower operates after the heat demand has been satisfied) is determined by the arrangement of a jumper across pins on the BCC2-3 blower control board. See figure 15. To adjust fan “off” timing, gently disconnect jumper and reposition across pins corresponding with new timing. Fan “on” time is factory set at 45 seconds and is not adjustable.

*NOTE—If fan “off” time is set too low, residual heat in heat exchanger may cause primary limit S10 to trip resulting in frequent cycling of blower. If this occurs, adjust blower to longer time setting.*

Figure 15 shows the various fan “off” timings and how jumper should be positioned. Unit is shipped with a factory fan “off” setting of 90 seconds. Fan “off” time will affect comfort and efficiency and is adjustable to satisfy individual applications. The fan “off” timing is initiated after a heating demand but not after a blower or cooling demand (that is, when indoor thermostat switch is changed from ON to AUTO and heating/cooling demand is not present, the blower stops immediately).



**FIGURE 15**



**FIGURE 16**

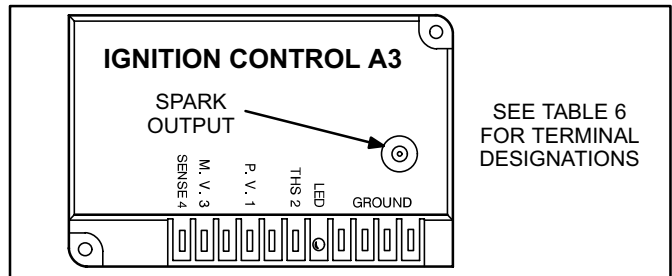
**12-Ignition Control (-1 and -2 models)**

G26 -1 and -2 model units use an intermittent pilot ignition manufactured by Johnson Controls. The ignition control is located on the upper vest panel.

**Unit Operation**

When there is a call for heat, the control is prevented from beginning an ignition sequence until the pressure switch proves combustion air blower operation. When the pressure switch closes, the control generates a spark and opens the pilot valve to ignite the pilot. When flame is sensed, the control opens the main gas valve and the pilot ignites the main burners. The indoor blower starts after a 45 second delay. Gas valve remains open and combustion air blower continues to run until demand stops, flame sensor senses loss of flame, a limit opens or the prove switch opens. If any of these events occur during a thermostat demand, the gas valve closes.

The control will attempt ignition for 85 seconds. If ignition is not successful, the control will lockout (indicated by flashing LED). Within one hour the control will momentarily remove then reapply the thermostat signal and the ignition sequence will begin again (Watchguard circuit). If pilot ignition is successful, but flame is lost when the main valve opens, the ignition sequence will retry up to 15 more times. If ignition is not successful after the 16th try, the control will shut-down and must be reset manually. Manual reset is accomplished by removing thermostat demand for at least 2 seconds then reapplying demand.



**FIGURE 17**

**⚠ DANGER**

**Shock hazard. Spark related components contain high voltage. Disconnect power before servicing. Control is not field repairable. If control is inoperable, simply replace entire control. Can cause injury or death. Unsafe operation will result if repair is attempted.**

**TABLE 6**

IGNITION CONTROL A3 TERMINAL DESIGNATIONS		
Terminal	Type	Function
GROUND	1/4" Spade	Cabinet Ground
THS 2	1/4" Spade	Safety Limit 24VAC Input From Differential Switch
P.V.1	1/4" Spade	24VAC Output to Pilot Operator of Gas Valve
M.V.3	1/4" Spade	24VAC Output to Main Operator of Gas Valve
SENSE 4	1/4" Spade	Microamp Flame Sensing Input
Unmarked	Pin Type Bare Wire	High Voltage Spark Output

### Diagnostic LED

The furnace control is equipped with a diagnostic LED used for troubleshooting the unit and the control. LED functions are shown in table 7.

**TABLE 7**

Furnace Control A3 Diagnostic LED		
LED State	Meaning	Remedy
Steady On	Normal Operation	----
Slow Flash (1 sec. on/ 5 sec. off)	Control Retry Period	Failed to Sense Flame. Ignition Control Will Retry Before Locking Out.
Off	Control Failure or Power Failure or Hard Lockout	If Power and Gas Supply are OK, Try Removing T'stat Demand For At Least 30 Seconds. If LED Remains Off When Demand Is Returned, Replace Control.

**TABLE 8**

BLOWER CONTROL A15 TERMINAL DESIGNATIONS		
Terminal (Designation on Wiring Diagram)	Type	Function
Y	Detachable Screw Strip	Cooling Demand
G	Detachable Screw Strip	Blower Demand
R	Detachable Screw Strip	24VAC to Thermostat
W	Detachable Screw Strip	Heating Demand
T	Detachable Screw Strip	24VAC Common To Indoor Thermostat
IBN (N)	1/4" Spade	120VAC Indoor Blower Common
N1 (N)	1/4" Spade	120VAC Neutral (L2 Line Voltage Neutral)
CABN (N)	1/4" Spade	120VAC Combustion Air Blower Com- mon
XFMRN(N)	1/4" Spade	120VAC Transformer Common
HSIN (N)	1/4" Spade	120VAC Hot Surface Ignition Common (Not Used)
CAB	1/4" Spade	Switched 120VAC to Combustion Air Blower
L1	1/4" Spade	120VAC Line Voltage In
A	1/4" Spade	Switched 120VAC to Blower Cooling Tap
XFMR	1/4" Spade	24VAC In From Transformer
D	1/4" Spade	Dummy Connection for Unused Blower Leads
CF	1/4" Spade	Switched 120VAC to Continuous Blower Tap
H	1/4" Spade	Switched 120VAC to Blower Heating Tap
ACC	1/4" Spade	Switched 120VAC to Accessory (Elec- tronic Air Cleaner, Humidifier, Etc.)
24V (24)	1/4" Spade	24VAC Input From Transformer
LIMIT (L)	1/4" Spade	24VAC In From Primary Limit. Limit Open: Closes Gas Valve and Turns On Blower Limit Closed: Allows Ignition
W	1/4" Spade	24VAC Thermostat Demand Output Through Differential Switch to "THS" Terminal of Ignition Control
VALVE SENSE (V)	3/16" Spade	24VAC Input From Gas Valve
T	1/4" Spade	24VAC Common From Ignition Control and Gas Valve
COM (C)	1/4" Spade	24VAC Common To Transformer

### Johnson G776 Ignition Control Operation

The information in this section is protected by a copyright issued by Johnson Controls, Inc., and is reproduced with permission.

On a call for heat from indoor thermostat, the ignition control energizes and ignition control LED lights (steady on). The combustion air blower is energized. After 15 second pre-purge period, the control simultaneously opens pilot valve and sends spark to pilot electrode.

If pilot ignites within 85 seconds, flame sensor detects pilot flame and signals ignition control to energize the main valve. The main valve cannot be energized until sensor detects pilot flame. Spark continues until pilot flame is sensed or 85 seconds has elapsed.

When pilot flame is sensed, main valve is energized and spark turns off. The ignition control remains in "run" mode until indoor thermostat is satisfied or flame lost.

If pilot flame is not sensed before the end of the 85 second trial for ignition, the control enters the 100% shutoff mode. The spark circuit and pilot valve de-energize and the ignition control automatically begins the 60 minute retry delay period. During the 60 minute delay the diagnostic LED continually flashes on for one second and off for five seconds. After the delay period, another trial for ignition sequence starts, beginning with pre-purge.

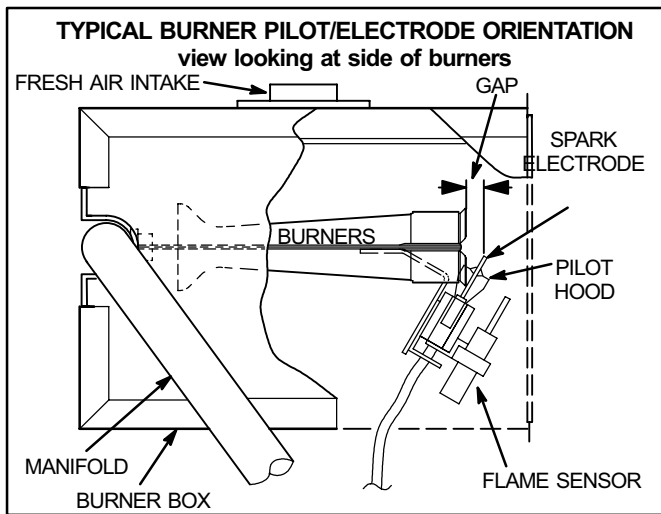
If pilot flame goes out while the indoor thermostat is calling for heat, both main and pilot valves de-energize within 0.8 seconds and remain de-energized for five seconds. After this delay, the spark and pilot valve energize until flame is sensed or the 85 second trial for ignition period ends. If this "flameout" cycle repeats 16 times (pilot flame is established and then lost), the control locks out and the LED goes off. A new trial for ignition sequence begins after the thermostat contacts are opened for 2 seconds and then closed.

If flame is detected when the thermostat calls for heat, it must extinguish within 30 seconds for normal operation. If flame is still present after 30 seconds, the control goes into lockout and the LED goes off.

### 13-Pilot, Spark Electrode, Flame Sensor (-1 and -2 models)

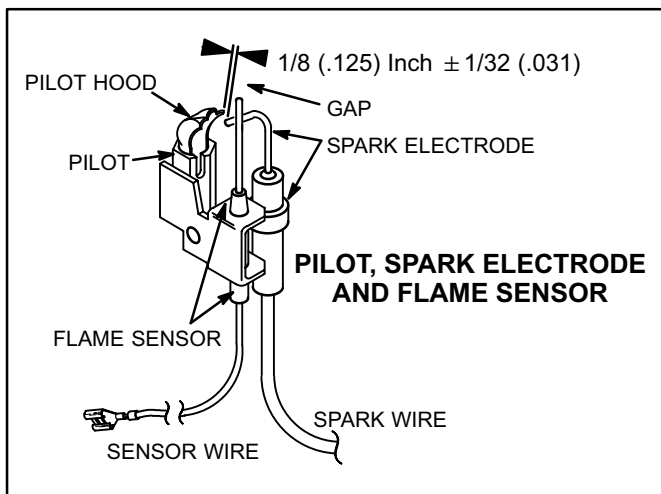
Figure 18 shows the arrangement of pilot, flame sensor, spark electrode and burners. The ignition control uses direct spark to ignite the pilot. The pilot ignites the burners and the burners cross-light. The flame sensor uses flame rectification to sense pilot ignition. The ignition control requires that pilot flame must be sensed before the main gas valve is allowed to open. Typically, a 2 to 4 second delay occurs between the pilot ignition and the main valve opening. Figure 19 shows the gap between the tip of the electrodes and the burner surface. It is important that the gap be maintained for consistent ignition of pilot flame.





**FIGURE 18**

Both pilot and main burner flame should be predominantly blue and strong in appearance. Pilot flame must surround the end of flame sensor for proper operation of pilot safety circuit.



**FIGURE 19**

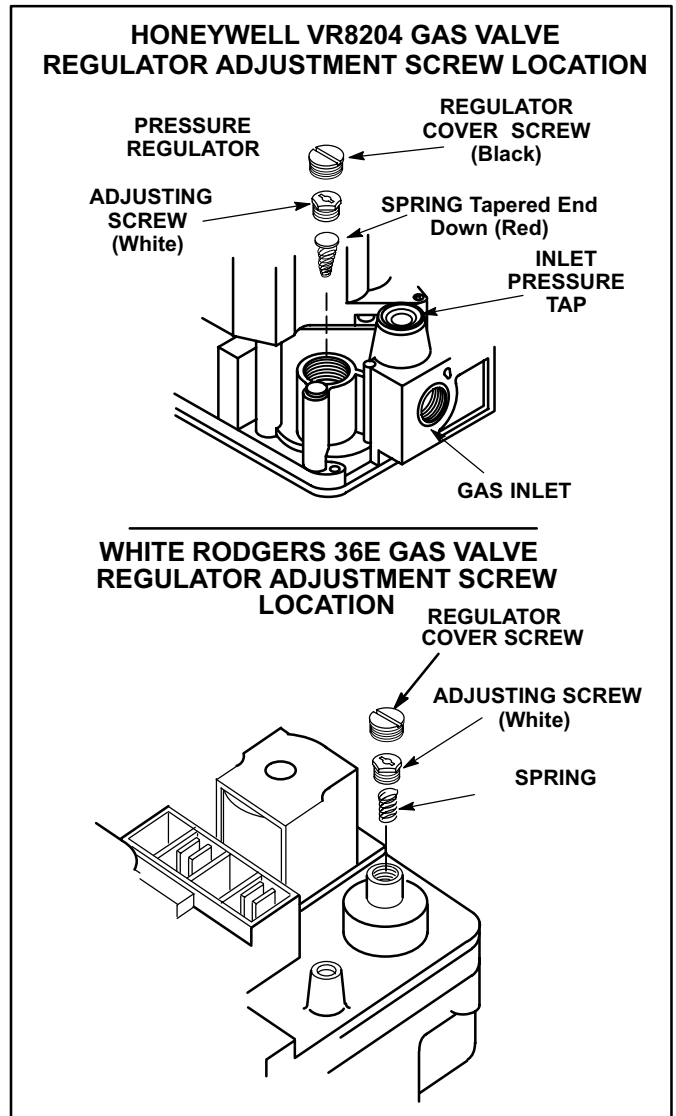
### 14-Gas Valve

The G26 uses a gas valve manufactured by Honeywell or White Rodgers. See figure 20. The valve is internally redundant to assure safety shut-off. If the gas valve must be replaced, the same type valve must be used.

24VAC terminals and gas control knob are located on top of the valve. All terminals on the gas valve are connected to wires from the ignition control. 24V applied to the "MV" terminals on the Honeywell or M/C or 1/2 terminals on the White Rodgers opens the main valve. Inlet and outlet pressure taps are located on the valve. A regulator adjustment screw (figure 20) is located on the valve. Regulator cover screw must be in

place when reading manifold pressure.

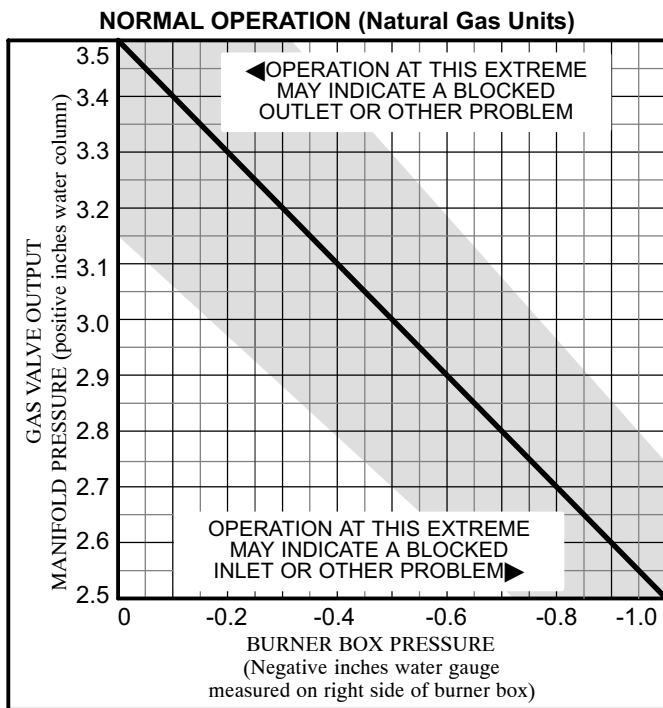
An LPG changeover kit is available. The kit includes main and pilot burner orifices (pilot orifice for -1 and -2 units only) and a regulator conversion kit. All L.P. orifices can be identified by a band around the orifice. Natural gas orifices do not have the band.



**FIGURE 20**

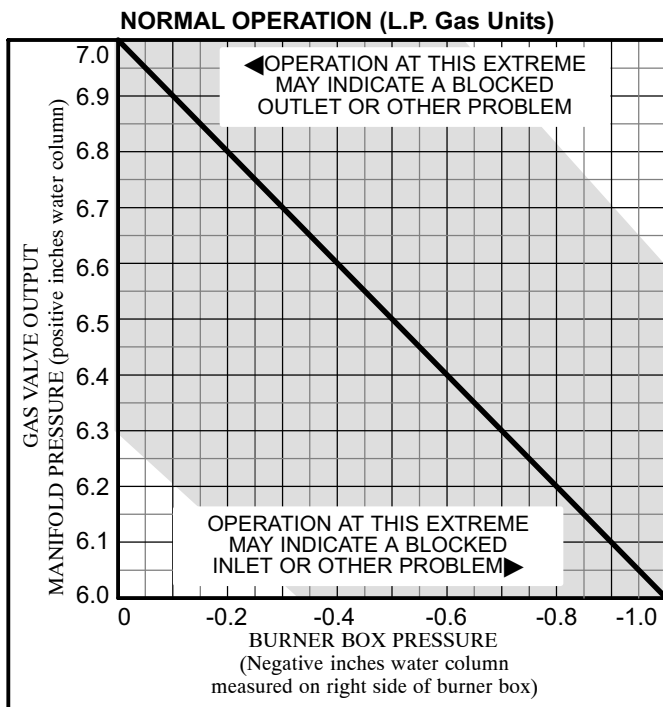
### 100% Sealed Combustion

The burner box is completely sealed and operates under a negative pressure. A pressure hose is connected from the burner box to the gas valve regulator and differential pressure switch. The gas valve senses the pressure in the burner box and changes gas valve output based on changes in burner box pressure. The intent is to compensate for different vent configurations which can greatly affect the rate of the unit.



Gray area indicates normal operating range  $\pm$  10% of manifold pressure. The purpose of this chart is to explain unit operation. Each unit may vary depending on installation, altitude, intake/exhaust configuration and other factors.

**FIGURE 21**



Gray area indicates normal operating range  $\pm$  10% of manifold pressure. The purpose of this chart is to explain unit operation. Each unit may vary depending on installation, altitude, intake/exhaust configuration and other factors.

**FIGURE 22**

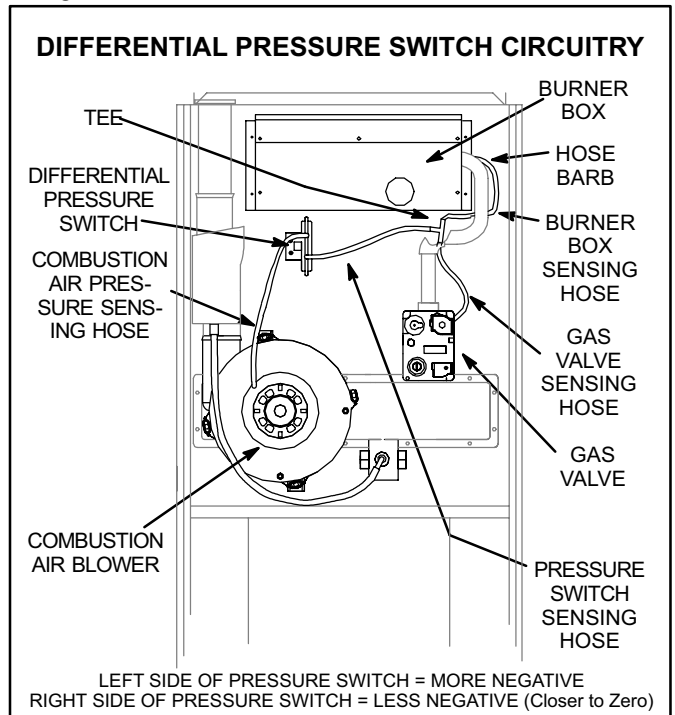
Figures 21 and 22 show how gas valve output changes as burner box pressure changes. Generally, a lower burner box pressure produces a leaner gas/air mixture and a higher burner box pressure produces a richer mixture. A procedure showing how to check manifold pressure is shown on page 29.

## 15-Differential Pressure Switch (S64) (Combustion Air Prove Switch)

G26 series units are equipped with a differential pressure switch located on the vestibule panel. The switch is connected to the combustion air blower housing by means of a flexible silicon hose. A separate hose connects the pressure switch to the burner box and the gas valve regulator. The switch monitors air pressure in the combustion air blower housing and burner box.

The switch is a single-pole single-throw normally open pressure switch electrically connected in series with the ignition control. The purpose of the switch is to prevent burner operation if the combustion air blower is not operating or if sufficient combustion air is not available,

On start-up, the switch senses that the combustion air blower is operating. It closes a circuit to the ignition control when the difference in pressure across the pressure switch increases above 0.2 in. w.c. The pressure sensed by the switch is relative to the pressure in the burner box. **In order for the furnace to operate, the larger negative must always be on the combustion air blower side of the switch.** If the flue or air inlet become obstructed during operation, the switch senses a loss of pressure differential (drops below 0.20 in. negative w.c.) and opens the circuit to the ignition control.

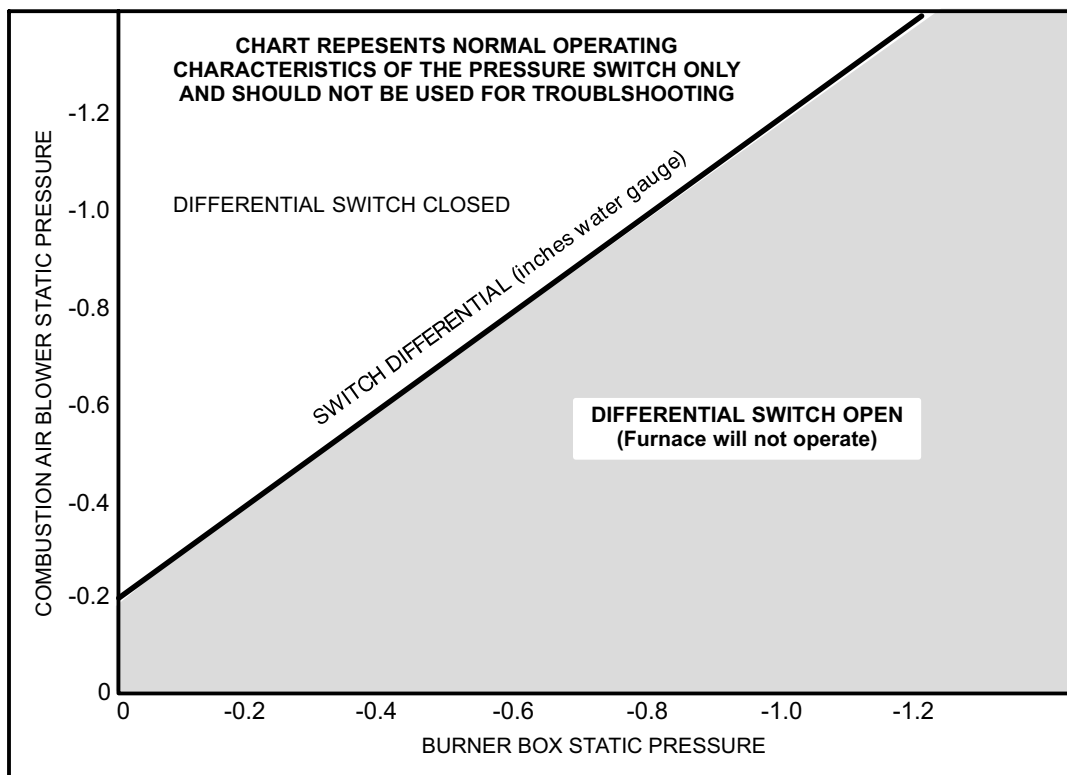


**FIGURE 23**

The switch is factory set and is not adjustable. It is a safety shut-down control and **MUST** not be bypassed.

Figure 24 shows the pressure differential required to obtain unit operation. If the switch does not successfully sense the required differential, the switch cannot close and the furnace cannot operate.

When measuring the pressure differential, readings should be taken at the pressure switch.



**FIGURE 24**

Temporarily jumpering the pressure switch when troubleshooting will determine if the pressure switch and furnace are operating properly. However, this may not indicate if the sealed combustion system is operating properly. If the unit cannot attain 0.2 inches differential, the unit will not operate. Be sure to remove jumper when finished. See Warning this page.

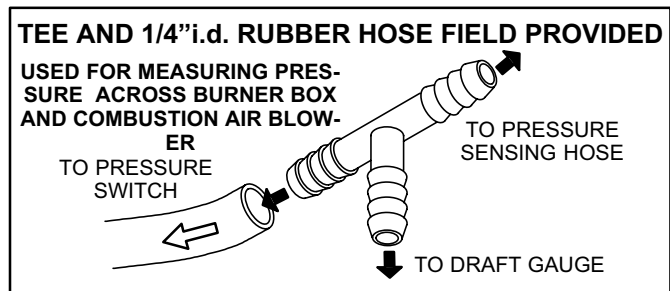
**Measuring pressure differential**

The differential pressure is the difference in pressure measured on either side of the pressure switch:

- 1 - Remove thermostat demand and allow to cycle off.
- 2 - Disconnect hose from left side of pressure switch and install Tee as shown in figure 25.

**⚠ WARNING**

**Safety Hazard. Turn off gas supply before jumpering switch or testing switch differential. If switch is operating properly and sealed combustion system is operating improperly, a potentially lethal situation will be created when switch is bypassed. DO NOT ALLOW UNIT TO OPERATE WITH SAFETY SYSTEMS BYPASSED.**



**FIGURE 25**

Checks of pressure differential can be made as an aid in troubleshooting. It is important to remember that the switch must "see" 0.2 inches differential in order for the furnace to operate. Lack of differential usually indicates problems in the intake or exhaust piping but may indicate problems in the heat exchanger, condenser coil, header boxes, combustion blower or other components. Generally, if both readings are closer to zero (figure 24) the unit may have a restricted flue outlet or other problem. If both readings are farther from zero (figure 24) the unit may have a restricted flue inlet or other problem.

- 3 - Install draft gauge to open end of Tee.
- 4 - Operate unit and observe draft gauge reading. *Readings will change as heat exchanger warms.*
  - a. Take one reading immediately after startup.
  - b. Take a second reading after unit has reached steady state (approximately 5 minutes).
- 5 - Remove thermostat demand and allow to cycle off.
- 6 - Remove draft gauge and Tee. Reinstall combustion air sensing hose to left side of pressure switch.
- 7 - Disconnect hose from right side of pressure switch and install Tee as shown in figure 25.
- 8 - Install draft gauge to open end of Tee.

- 9 - Operate unit and observe draft gauge reading. *Readings will change as heat exchanger warms.*
  - a. Take one reading immediately after startup.
  - b. Take a second reading after unit has reached steady state (approximately 5 minutes). Both readings should fall above the line shown in figure 24.

- 10- Compare readings to figure 24. Be sure to compare only like readings (compare startup reading to startup reading, then compare steady state reading to steady state reading). Subtract the absolute steady state readings from one another. This will be the pressure differential. **In order for the furnace to operate, the larger negative must always be on the combustion air blower side of the switch**

Example - one side of the pressure switch reads .60" and the other side of the pressure switch reads .10". Pressure differential is .60" - .10" = .50"

**The pressure differential should be greater than 0.20" W.C. (49.72Pa).**

- 11- When test is complete, remove thermostat demand and allow unit to cycle off.
- 12- Remove draft gauge and Tee. Reinstall pressure switch sensing hose to left side of pressure switch.

If pressure switch does not close at start up or differential is less than .20" the following should be checked.

- 1 - Restriction in exhaust and or intake vent.
- 2 - Pressure switch lines are routed correctly and for damage.
- 3 - Condensate in pressure switch lines.
- 4 - Wiring of pressure switch to furnace.
- 5 - Blocked heat exchanger or leak in heat exchanger.

## II-PLACEMENT AND INSTALLATION

Make sure unit is installed in accordance with installation instructions and applicable codes.

### A-PVC Joint Cementing Procedure

#### **WARNING**

**DANGER OF EXPLOSION! Fumes from PVC glue may ignite during system check. Remove spark plug wire from ignition control before 120V power is applied. Reconnect wire after two minutes.**

- 1 - Measure and cut vent pipe to desired length.
- 2 - Debur and chamfer end of pipe, removing any ridges or rough edges. If end is not chamfered, edge of pipe may remove cement from fitting socket and result in a leaking joint.
- 3 - Clean and dry surfaces to be joined.
- 4 - Test fit joint and mark depth of fitting on outside of pipe.
- 5 - Uniformly apply liberal coat of PVC primer for PVC or ABS cleaner for ABS for at least 5 to 15 seconds to inside socket surface of fitting and male end of pipe to depth of fitting socket. Remove puddles of primer before applying cement.

- 6 - Promptly apply solvent cement to end of pipe and inside socket surface of fitting. Cement should be applied lightly but uniformly to inside of socket. Take care to keep excess cement out of socket. Apply second coat to end of pipe.

*NOTE-Time is critical at this stage. Do not allow primer to dry before applying cement.*

- 7 - Immediately after applying last coat of cement to pipe, and while both inside socket surface and end of pipe are wet with cement, forcefully insert end of pipe into socket until it bottoms out. Turn pipe 1/4 turn during assembly (but not after pipe is fully inserted) to distribute cement evenly. Once joint is made, PVC may swell. Hold joint together until bonded (approximately 20 seconds).

*NOTE-Assembly should be completed within 20 seconds after last application of cement. Hammer blows should not be used when inserting pipe.*

- 8 - After assembly, wipe excess cement from pipe at end of fitting socket. A properly made joint will show a bead around its entire perimeter. Any gaps may indicate a defective assembly due to insufficient solvent.
- 9 - Handle joints carefully and support properly until completely set.

### B-Venting Considerations

The thickness of construction through which vent/air intake pipes may be installed is 24" (610mm) maximum and 3" (76mm) minimum. If a G26 furnace replaces a furnace which was commonly vented with another gas appliance, the size of the existing vent pipe for that gas appliance must be checked. Without the heat of the original furnace flue products, the existing vent pipe may be oversized for the single water heater or other appliance. The vent should be checked for proper draw with the remaining appliance.

#### **CAUTION**

**Insufficient combustion air can cause headaches, nausea, dizziness or asphyxiation. Excessive exposure to contaminated combustion air will result in safety and performance related problems. Avoid exposure to the following substances in the combustion air supply:**

**Permanent wave solutions;  
Chlorinated waxes and cleaners;  
Chlorine base swimming pool chemicals;  
Water softening chemicals;  
De-icing salts or chemicals;  
Carbon tetrachloride;  
Halogen type refrigerants;  
Cleaning solvents (such as perchloroethylene);  
Printing inks, paint removers, varnishes, etc.;  
Hydrochloric acid;  
Cements and glues;  
Antistatic fabric softeners for clothes dryers; and  
Masonry acid washing materials.**

## Intake Piping

- 1 - Cement intake piping in slip connector located at top of unit.
- 2 - Route piping to outside of structure. Continue with installation following instructions given in exhaust and intake piping termination section.

## Exhaust Piping

- 1 - Cement exhaust piping into flue collar socket located on the left side of the top cap.
- 2 - All horizontal runs of exhaust pipe must slope back toward unit. A minimum of 1/4" (6mm) drop for each 12" (305mm) of horizontal run is mandatory for drainage. Horizontal runs of exhaust piping must be supported every 5 ft. (1.52m) using hangers for schedule 40 pipe. All other pipe must be supported every 3 ft. (.91m).

*NOTE - Exhaust piping should be checked carefully to make sure there are no sags or low spots.*

*NOTE - Exhaust piping must be insulated with 1/2" (13mm) Armaflex or equivalent when run through unheated space. Do not leave any area of exhaust pipe open to outside air; exterior exhaust must be insulated with 1/2" (13mm) Armaflex or equivalent.*

### CAUTION

**Do not discharge exhaust into an existing stack or stack that also serves another gas appliance. If vertical discharge through an existing unused stack is required, insert PVC pipe inside the stack until the end is beyond the top or outlet end of the metal stack.**

### CAUTION

**The exhaust vent pipe operates under positive pressure and must be completely sealed to prevent leakage of combustion products into the living space.**

## Removal of Unit from Common Venting System

In the event that an existing furnace is removed from a venting system commonly run with separate gas appliances, the venting system may be too large to properly vent the remaining attached appliances. The following test should be conducted while all appliances (both in operation and those not in operation) are connected to the common venting system. If the venting system has been installed improperly, corrections must be made as outlined in the previous section.

- 1 - Seal any unused openings in the common venting system.
- 2 - Visually inspect the venting system from proper size and horizontal pitch and determine there is no blockage or restriction, leakage, corrosion and other deficiencies which could cause an unsafe condition.
- 3 - Insofar as is practical, close all building doors and windows and all doors between the space in which the appliances remaining connected to the common venting system are located and other spaces of the building. Turn on clothes dryers and any appliances not connected to the common venting system. Turn on any exhaust fans, such as range hoods and bathroom exhausts, so they will operate at maximum speed. Do not operate a summer exhaust fan. Close fireplace dampers.
- 4 - Follow the lighting instruction. Place the appliance being inspected in operation. Adjust thermostat so appliance will operate continuously.
- 5 - Test for spillage at the draft hood relief opening after 5 minutes of main burner operation. Use the flame of match or candle, or smoke from a cigarette, cigar.
- 6 - After it has been determined that each appliance remaining connected to the common venting system properly vents when tested as outlined above, return doors, windows, exhaust fans, fireplace dampers and any other gas-burning appliance to their previous condition of use.
- 7 - If improper venting is observed during any of the above tests, the common venting system must be corrected. The common venting system should be resized to approach the minimum size as determined by using the appropriate tables in appendix G in the current standards of the National Fuel Gas Code ANSI Z223-1 in the U.S.A., and the appropriate Category 1 Natural Gas and Propane appliances venting sizing tables in the current standards of the CAN/CGA-B149.1 and .2 in the Natural Gas and Propane Installation Code in Canada.

## Intake and Exhaust Piping Terminations

Intake and exhaust pipes may be routed either horizontally through an outside wall or vertically through the roof. In attic or closet installations, vertical termination through the roof is preferred. Figures 26 through 38 show typical terminations.

- 1 - Use recommended piping materials for both intake and exhaust piping.
- 2 - Secure all joints, including drain leg, gas tight using approved primer and cement.

3 - Piping diameters should be determined according to length of pipe run. See vent pipe specifications on page 6. Locate intake piping upwind (prevailing wind) from exhaust piping. To avoid re-circulation of exhaust gas on roof terminations, end of exhaust pipe must be higher than intake pipe.

Exhaust and intake exits must be in same pressure zone. Do not exit one through the roof and one on the side. Also, do not exit the intake on one side and the exhaust on another side of the house or structure.

4 - Intake and exhaust pipes should be placed as close together as possible at termination end (refer to illustrations). Maximum separation is 3" (76mm) on roof terminations and 6" (152mm) on side wall terminations.

5 - Exhaust piping must terminate straight out or up as shown. In rooftop applications, a 2" X 1-1/2" reducer for 2" venting, 3" x 2" reducer for 3" venting must be used on the exhaust piping after it exits the structure to improve the velocity of exhaust away from the intake piping.

On roof terminations, the intake piping should terminate straight down using two 90° elbows (See figure 26).

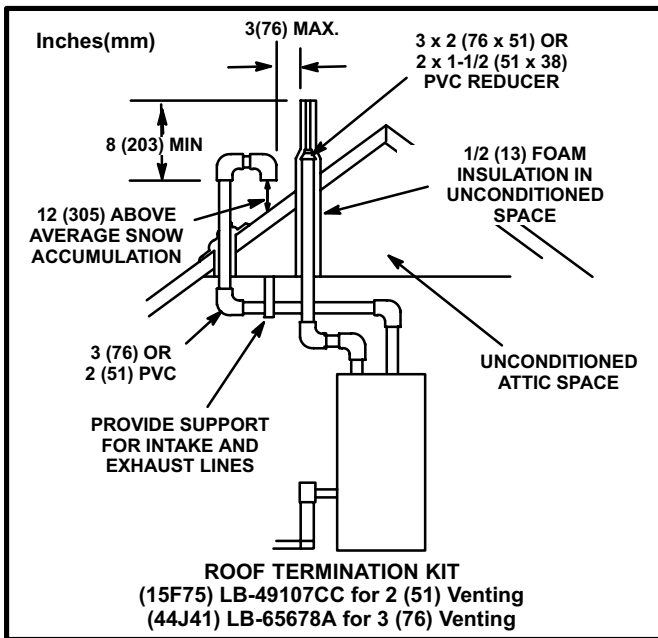


FIGURE 26

**▲ IMPORTANT**

Do not use screens or perforated metal in intake and exhaust terminations. Doing so will cause freeze-ups and may block the terminations.

*NOTE - If winter design temperature is below 32° F (0° C), exhaust piping must be insulated with 1/2" (13mm), Armaflex or equivalent when run through unheated space. Do not leave any surface area of exhaust pipe open to outside air; exterior exhaust pipe must be insulated with 1/2" (13mm) Armaflex or equivalent. In extreme cold climate areas, 3/4" (19mm) Armaflex or equivalent is recommended. Insulation on outside runs of exhaust pipe must be painted or wrapped to protect insulation from deterioration.*

*NOTE - During extremely cold temperatures, below approximately 20° F (6.67° C), units with long runs of vent pipe through unconditioned space, even when insulated, may form ice in the exhaust termination that prevents the unit from operating properly. Longer run times of at least 5 minutes will alleviate most icing problems. Also, a heating cable may be installed on exhaust piping and termination to prevent freeze-ups. Heating cable installation kit is available from Lennox. See Condensate Piping section for part numbers.*

*NOTE - Care must be taken to avoid re-circulation of exhaust back into intake pipe.*

6 - On field supplied terminations for side wall exits, exhaust piping should extend a minimum of 12" (305mm) beyond the outside wall. Intake piping should be as short as possible. See figure 27.

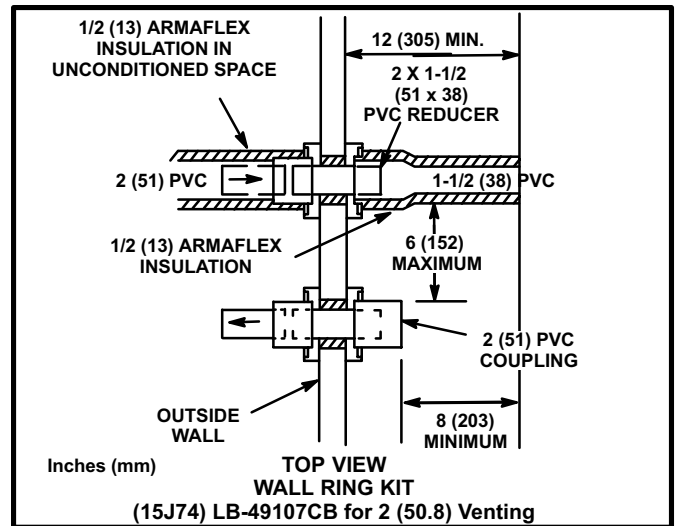


FIGURE 27

7 - On field supplied terminations, a minimum separation distance between the end of the exhaust pipe and the end of the intake pipe is 8" (203mm).

8 - If intake and exhaust piping must be run up a side wall to position above snow accumulation or other obstructions, piping must be supported every 3 ft. (.91m) as shown in figure 33. Refer to figures 31 and 32 for proper piping method. WTK wall termination kit must be extended for use in this application. See figure 36 or use kit WTKX shown in figure 37. When exhaust and intake piping must be run up an outside wall, the exhaust piping is reduced to 1-1/2" (38mm) after the final elbow. The intake piping may be equipped with a 90° elbow turndown. Using turndown will add 5ft. (1.5m) to the equivalent length of the pipe.

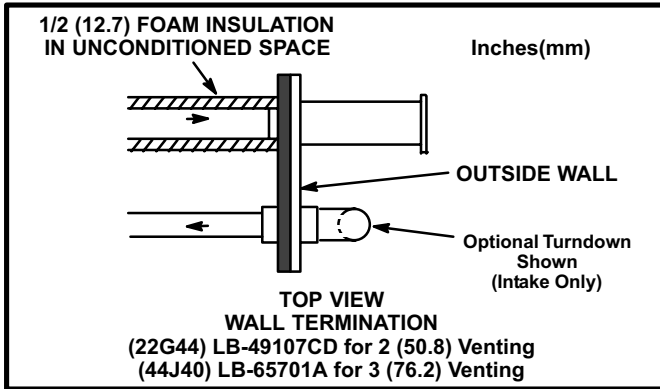


FIGURE 28

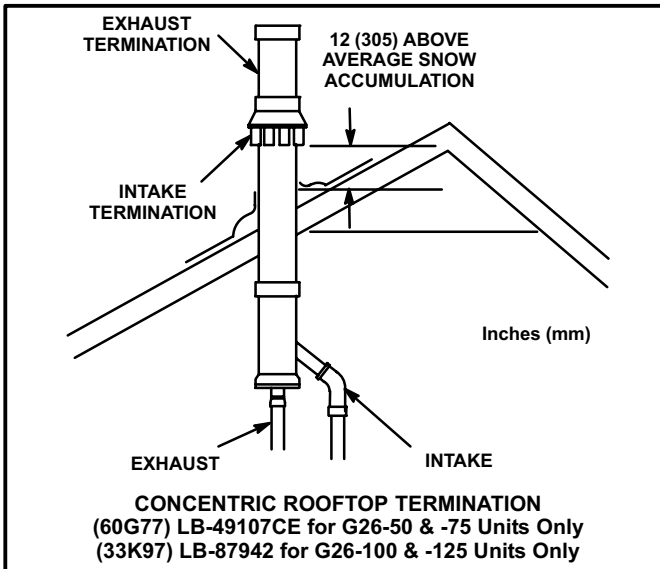


FIGURE 29

**⚠ IMPORTANT**

**For Canadian Installations Only:**  
In accordance to CAN/CGA-B149.1 and .2, the minimum allowed distance between the combustion air intake inlet and the exhaust outlet of other appliances shall not be less than 12" (305mm).

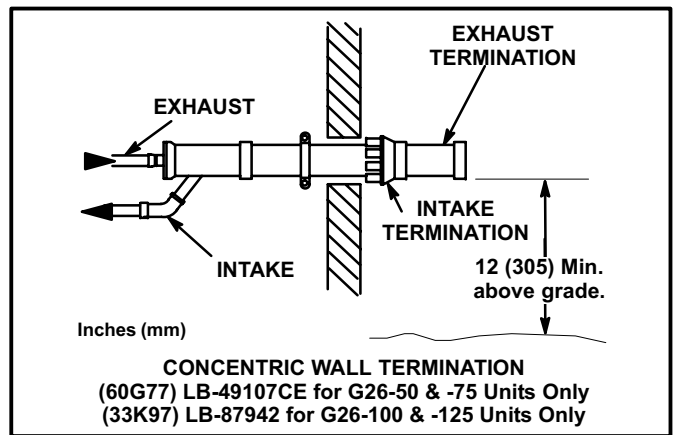


FIGURE 30

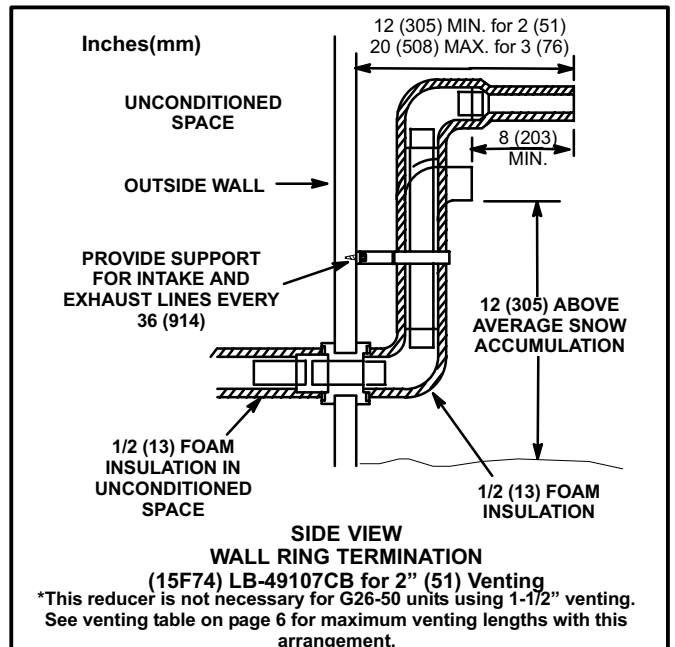


FIGURE 31

9 - Position termination ends so they are free from any obstructions and above the level of snow accumulation (where applicable). Termination ends must be a minimum of 12" (305mm) above grade level. Do not point into window wells, stairwells, alcoves, courtyard areas or other recessed areas. Do not position termination ends closer than 12" below roof eaves or above a walkway. Since the G26 is a certified direct vent, Category IV gas furnace, the location of the termination is limited by building codes. In the absence of local codes, refer to the current National Fuel Gas Code ANSI Z223-1 in U.S.A., and current standards CAN/CGA-B149.1 / .2 of the Natural Gas and Propane Installation Instructions in Canada for details. The termination should be at least 12" (305mm) from any opening through which flue products could enter the building.

When horizontally vented, minimum clearance for termination from electric meters, gas meters, regulators and relief equipment is 4 ft. (1.2m) for US installations. Refer to the current CAN/CGA-B149.1 and .2 for installations in Canada or with authorities having local jurisdiction.

At vent termination, care must be taken to maintain protective coatings over building materials (prolonged exposure to exhaust condensate can destroy protective coatings). It is recommended that the exhaust outlet not be located within 6 feet (1.8m) of a condensing unit because the condensate can damage the painted coating.

**⚠ IMPORTANT**

**Combustion air intake inlet and exhaust outlet should not be located within 6 ft. (1.8m) of dryer vent or combustion air inlet or outlet of another appliance. Piping should not exit less than 3 ft. (.91m) from opening into another building.**

- 10- Suspend piping using hangers at a minimum of every 5 feet (1.52m) for schedule 40 PVC and every 3 feet (.91m) for ABS-DWV, PVC-DWV, SPR-21 PVC, and SDR-26 PVC piping. A suitable hanger can be fabricated by using metal or plastic strapping or a large wire tie.
- 11- In areas where piping penetrates joists or interior walls, hole must be large enough to allow clearance on all sides of pipe through center of hole using a hanger.
- 12- Isolate piping at the point where it exits the outside wall or roof.
- 13- When furnace is installed in a residence where unit is shut down for an extended period of time, such as a vacation home, make provisions for draining condensate collection trap and lines.
- 14- Based on the recommendation of the manufacturer, a multiple furnace installation may use a group of up to four termination kits WTK assembled together horizontally, as shown in figure 35.

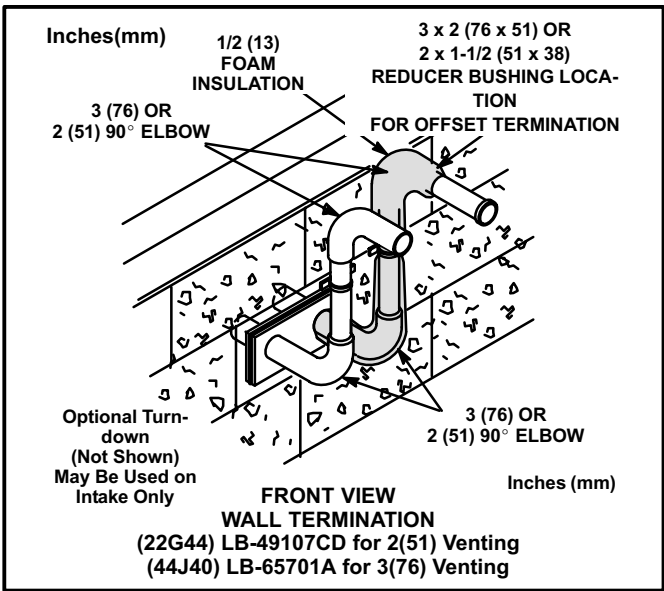


FIGURE 32

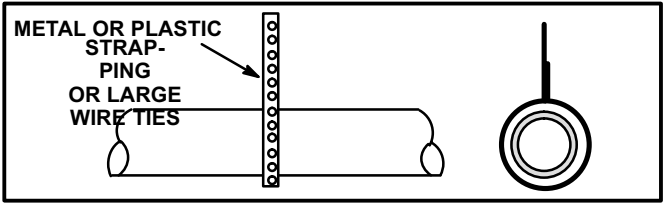


FIGURE 33

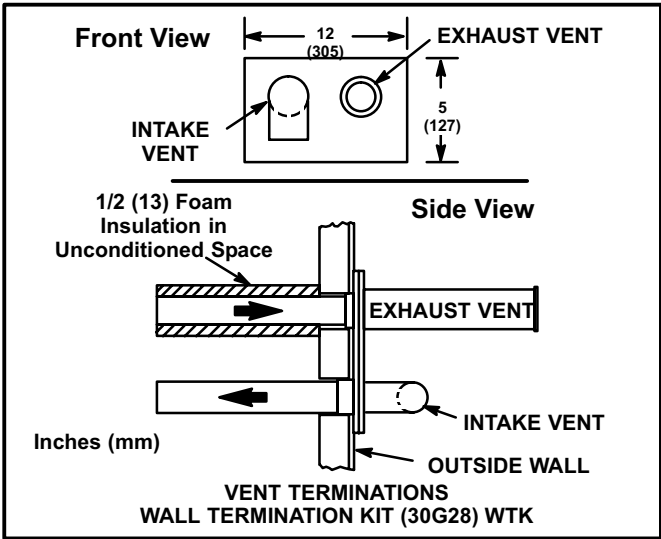


FIGURE 34



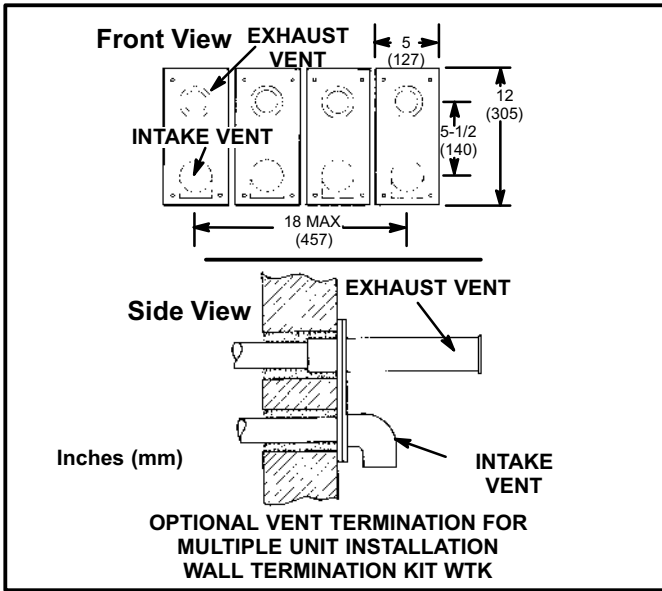


FIGURE 35

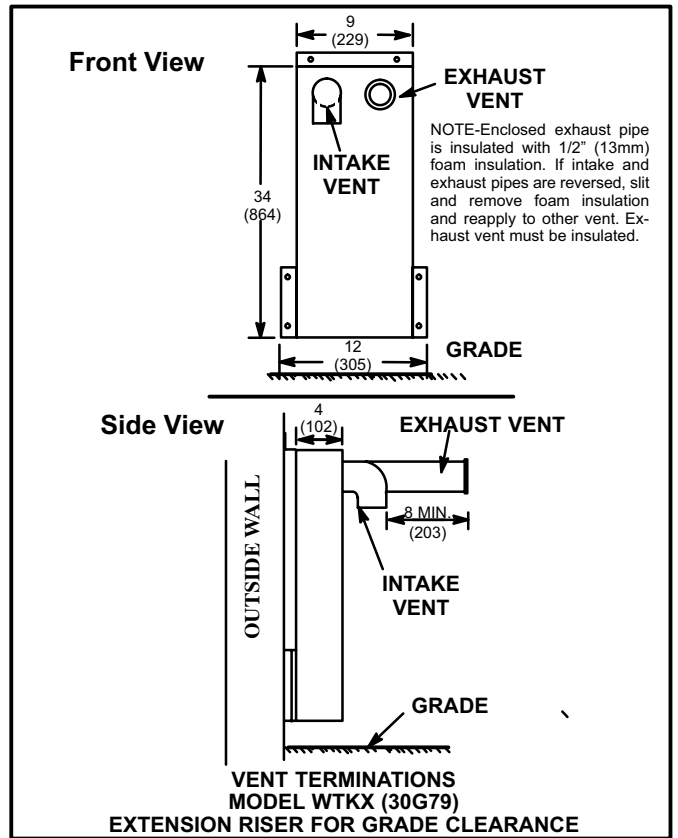


FIGURE 37

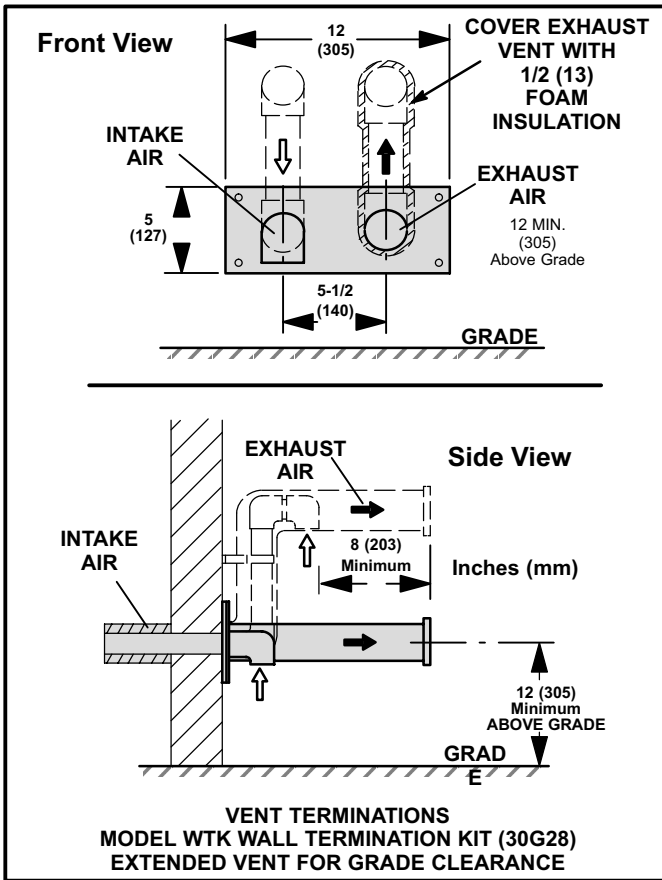


FIGURE 36

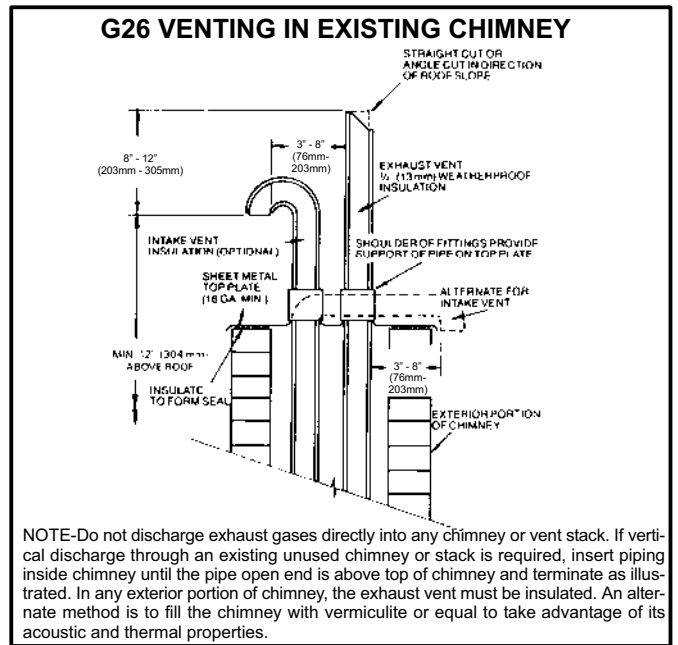


FIGURE 38

## Condensate Piping

This unit is designed for either right- or left-side exit of condensate piping. Condensate drain line should be routed only within the conditioned space to avoid freezing of condensate and blockage of drain line. An electric heat cable should be used where condensate drain is exposed to unconditioned areas. The following procedure is for all G26 units.

- 1 - Determine which side condensate will exit the unit.
- 2 - Connect 1/2" (13mm) plastic pipe plug (provided) in the unused end of the condensate trap. Install plug so that it is sealed water tight yet able to be removed. Do not permanently seal the connection. Teflon tape is recommended to seal joint. See figure 40.

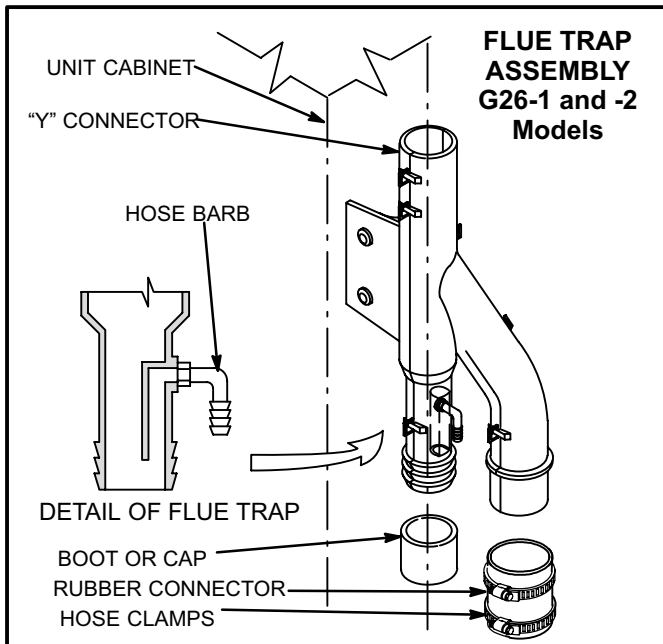


FIGURE 39

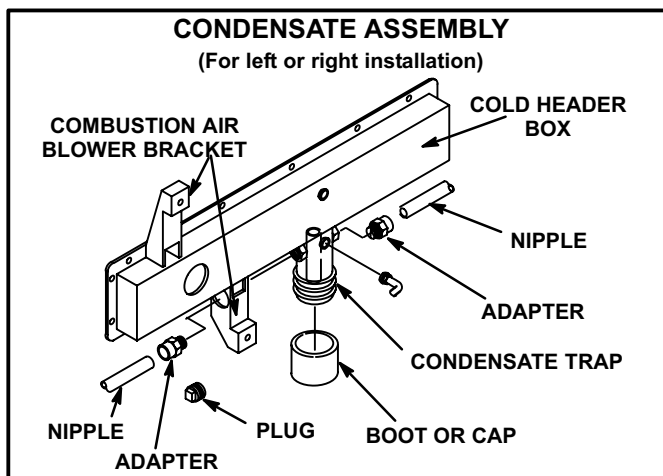


FIGURE 40

- 3 - Use the provided adapter (1/2" PVC x 1/2" MPT) and the nipple (1/2" PVC) to carry drainage outside the cabinet. If a field substitute is needed, 1/2" CPVC x 1/2" MPT adapter and 1/2" CPVC is acceptable for use.
- 4 - Glue nipple to the adapter using the procedures outlined in the "Joint Cementing Procedures" section. The nipple/adapter assembly should be connected in a non-permanent manner and must be water tight. Teflon tape is recommended to seal the joint.

### For Right-Hand Side Condensate Exit:

Install the nipple/adapter assembly from the outside of the cabinet and insert the adapter into the threaded opening in the condensate trap.

### For Left-Hand Side Condensate Exit:

Insert nipple/adapter assembly from the left hand side of the cabinet and through the combustion air blower mounting structure into the threaded opening in the condensate trap.

- 5 - Connect field supplied plumbing to nipple and route to open drain. Plumbing should be vented to a point higher than the condensing coil. See figure 41.

## CAUTION

Do not use copper tubing or existing copper condensate lines for drain line.

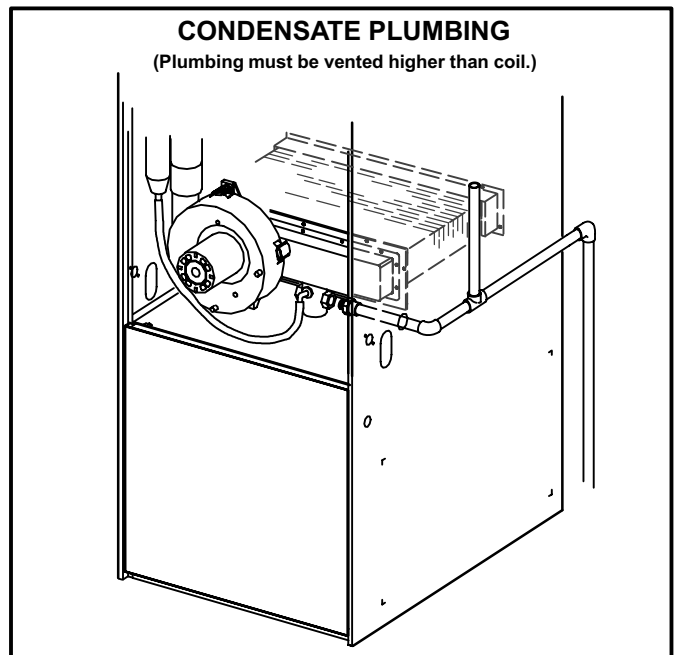
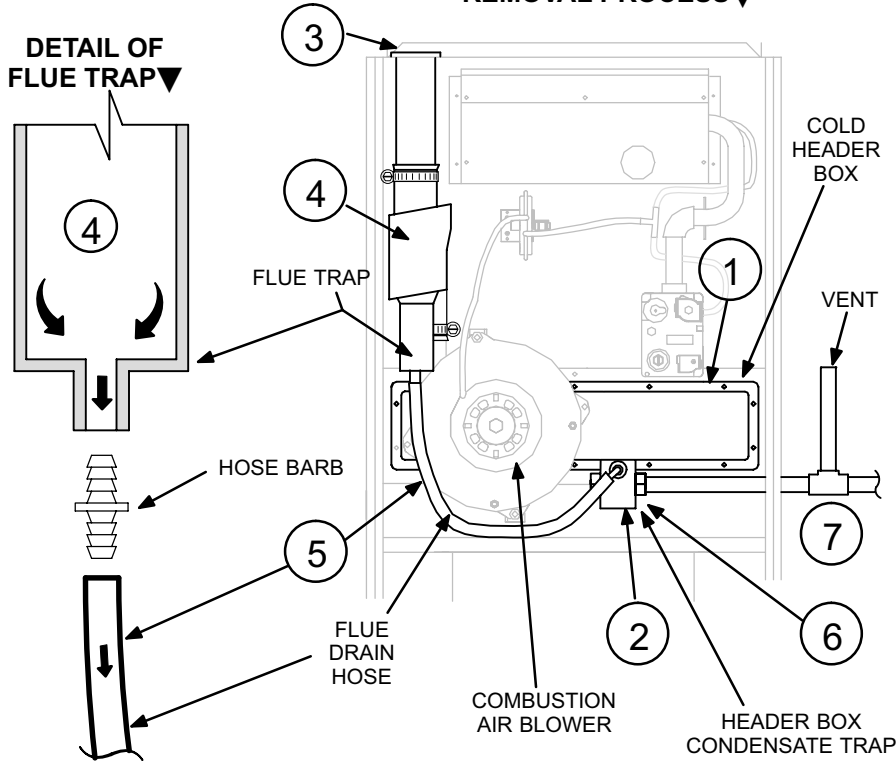


FIGURE 41

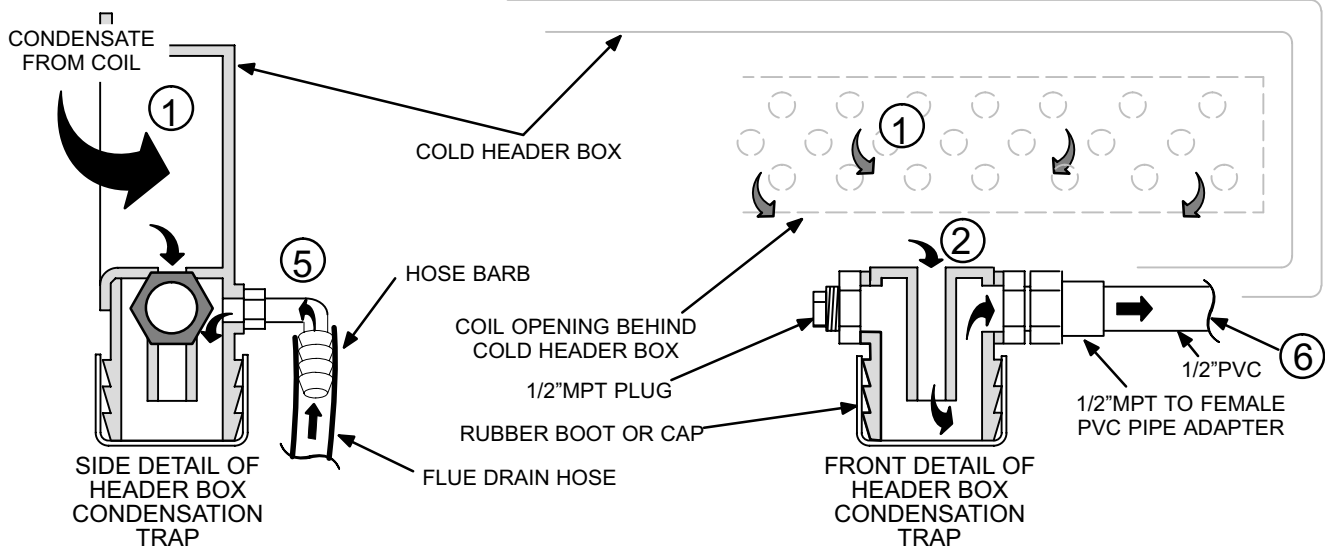
**G26 -3 THROUGH -6 MODEL CONDENSATE REMOVAL PROCESS▼**



**Condensate Removal Process:**

- 1- Condensate mixed with flue products exits the coil and enters the cold header box.
- 2- Condensate and flue products are separated. Flue products are drawn into the combustion air blower while condensate is drained into the header box condensate trap.
- 3- Flue products are expelled into the flue. As flue products travel up and out, they cool and more condensate is produced.
- 4- Condensate travels down the walls of the flue pipe and into drain hose.
- 5- Water drains down through the flue drain hose and is emptied into the header box condensate trap.
- 6- When the cold header box condensate trap is full, water begins draining out the condensate drain pipe.
- 7- An external condensate trap is not required, but a vent is required. The vent must extend above the height of the condenser coil (approx. 1 inch above the top of the cold header box).

**DETAIL OF COLD HEADER CONDENSATE TRAP▼**



**FIGURE 42**

6 - Connect condensate drain line (1/2" [13mm] SDR 11 plastic pipe or tubing) to condensate connection on drip leg assembly and route to open drain. Condensate line must be sloped downward away from drip leg to drain. If drain level is above drip leg, condensate pump must be used to condensate line. Condensate drain line should be routed within the conditioned

space to avoid freezing of condensate and blockage of drain line. If this is not possible, a heat cable kit may be used on the condensate drip leg and line. Heating cable kit is available from Lennox in various lengths; 6ft. (1.8m) - kit no. 18K48; 24ft. (7.3m) - kit no. 18K49; and 50ft. (15.2m) - kit no. 18K50.

### III-START-UP

#### A-Preliminary and Seasonal Checks

- 1 - Inspect electrical wiring, both field and factory installed for loose connections. Tighten as required.
- 2 - Check voltage at disconnect switch. Voltage must be within range listed on the nameplate. If not, consult the power company and have voltage condition corrected before starting unit.
- 3 - Inspect condition of condensate traps and drain assembly. Disassemble and clean seasonally.

#### B-Heating Start-Up

FOR YOUR SAFETY READ BEFORE LIGHTING

### ⚠ CAUTION

Shock and burn hazard.  
G26 units are equipped with the SureLight ignition system. Do not attempt to light manually.

### ⚠ WARNING

Do not use this furnace if any part has been underwater. Inspect the furnace and replace any part of the control system and any gas control which has been under water.

### ⚠ WARNING

If overheating occurs or if gas supply fails to shut off, shut off the manual gas valve to the appliance before shutting off electrical supply.

### ⚠ CAUTION

Before attempting to perform any service or maintenance, turn the electrical power to unit OFF at disconnect switch.

BEFORE LIGHTING smell all around the appliance area for gas. Be sure to smell next to the floor because some gas is heavier than air and will settle on the floor.

Use only your hand to push in or turn the gas control knob. Never use tools. If the knob will not push in or turn by hand, do not try to repair it, call a qualified service technician. Force or attempted repair may result in a fire or explosion. G26 units are equipped with the SureLight ignition system. DO NOT attempt to manually light burners on this furnace. Each time thermostat calls for heat, burners will be automatically lit. The ignitor does not get hot when there is no call for heat on units with SureLight ignition system.

#### How To Operate Gas Valve (Figure 43)

### ⚠ WARNING

If you do not follow these instructions exactly, a fire or explosion may result causing property damage, personal injury or loss of life.

- 1 - **STOP!** Read the safety information at the beginning of this section.
- 2 - Set thermostat to lowest setting.
- 3 - Turn off all electrical power to furnace.
- 4 - This appliance is equipped with an ignition device which automatically lights the burner. Do **not** try to light the burner by hand.
- 5 - Remove unit access panel.
- 6 - On Honeywell VR8204 gas valves, turn knob on gas valve clockwise ➡ to **OFF**. For White Rodgers 36E gas valves, move switch to **OFF**. Do not force. See figure 43.

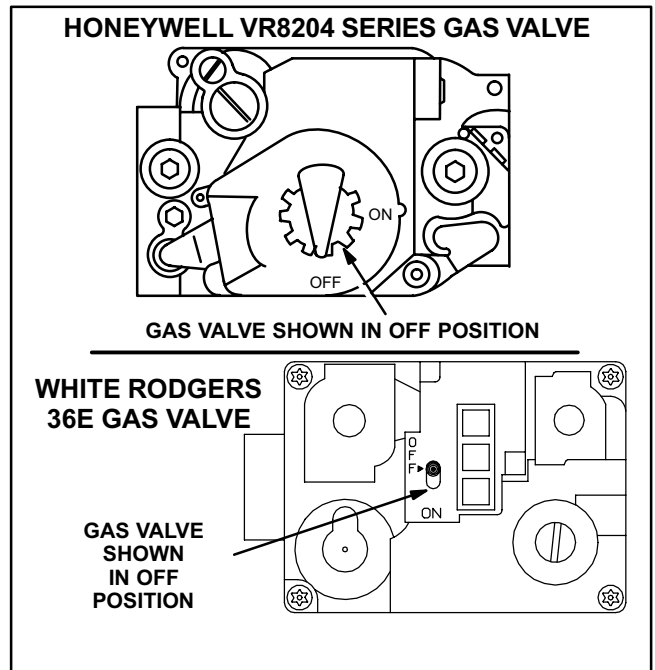


FIGURE 43


- 7 - Wait five (5) minutes to clear out any gas. If you then smell gas, STOP! Immediately call your gas supplier from a neighbor's phone. Follow the gas supplier's instructions. If you do not smell gas go to next step.
- 8 - For Honeywell VR8204 gas valves, turn knob on valve counterclockwise ⬅ to **ON**. For White Rodgers 36E gas valves, move switch to **ON**.
- 9 - Replace unit access panel.
- 10- Turn on all electrical power to unit.
- 11- Set thermostat to desired setting.

*NOTE-When unit is initially started, steps 1 through 11 may need to be repeated to purge air from pilot line.*

*NOTE- On initial start-ups and when condensate trap is dry, unit may turn itself off and on to allow condensate trap to fill. This is normal operation.*

- 12- If the furnace will not operate, follow the instructions "To Turn Off Gas To Unit" and call your service technician or gas supplier.

#### **To Turn Off Gas To Unit**

- 1 - Set thermostat to lowest setting.
- 2 - Turn off all electrical power to unit if service is to be performed.
- 3 - Remove heat section access panel.
- 4 - On Honeywell VR8204 gas valves, turn knob on gas valve clockwise  to **OFF**. For White Rodgers 36E gas valves, move switch to **OFF**. Do not force.
- 5 - Replace unit access panel.

#### **C-Safety or Emergency Shutdown**

Turn off unit power. Close manual and main gas valves.

#### **D-Extended Period Shutdown**

Turn off thermostat or set to "UNOCCUPIED" mode. Close all gas valves (both internal and external to unit) to guarantee no gas leak into combustion chamber. Turn off power to unit. All access panels, covers and vent caps must be in place and secured.

Refer to "Maintenance" section of this manual for instructions on how to prepare condensate assembly for extended period shutdown.

### **IV-HEATING SYSTEM SERVICE CHECKS**

#### **A-A.G.A./C.G.A. Certification**

All units are A.G.A. and C.G.A. design certified without modifications. Refer to the G26 Operation and Installation Instruction Manual Information.

#### **B-Exhaust CO<sup>2</sup> and CO content**

Carbon Dioxide is a colorless and odorless gas produced in small amounts by all furnaces, including the G26, during combustion process. When the unit is properly installed and operating normally, the CO<sup>2</sup> content of the exhaust is between 6.0% and 8.0% for natural gas and between 7.5% and 9.5% for L.P. gases. CO content will be less than 0.04% regardless of the gas used. If unit appears to be operating normally at or beyond the upper limit of the CO<sup>2</sup> range, the unit should be checked for abnormally high CO.

#### **Testing for abnormally high CO<sup>2</sup> and CO.**

One method for testing the CO<sup>2</sup>/CO content is the Bacharach CO<sup>2</sup> test with the Fyrite CO<sup>2</sup> indicator. Other methods of testing CO<sup>2</sup>/CO are available. Closely follow the instructions included in the test kit you choose. Follow the procedure below in order to check CO<sup>2</sup>/CO on the G26 furnace.

- 1 - Drill size "R" or 11/32 in. on the exhaust vent, just exiting the cabinet and tap 1/8-27 NPT. This hole will be used to draw your CO<sup>2</sup>/CO sample.
- 2 - Install a hose barb connector into test hole.
- 3 - Attach end of Fyrite sampling tube to hose barb.
- 4 - Set thermostat to highest setting and allow unit to run 15 minutes.
- 5 - When CO<sup>2</sup>/CO testing is complete, turn off unit, remove hose barb from exhaust vent and use a 1/8" plastic plug to close off port.

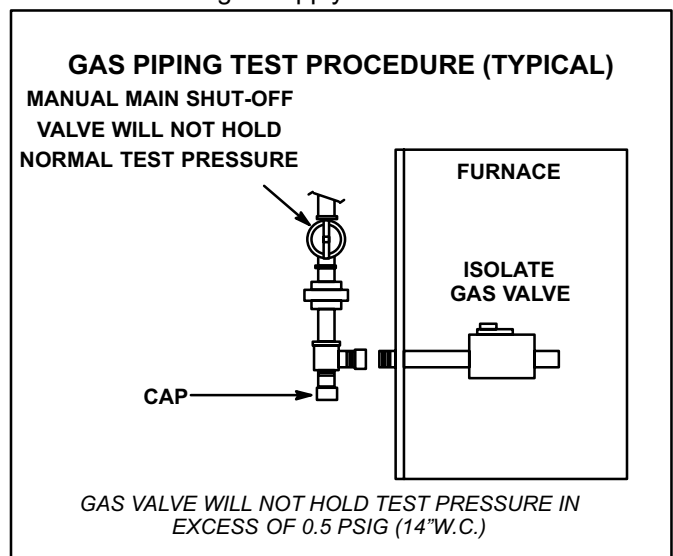
#### **C-Gas Piping**

Gas supply piping should not allow more than 0.5"W.C. drop in pressure between gas meter and unit. Supply gas pipe must not be smaller than unit gas connection. See gas pipe capacity table on page 6 of this manual.

Compounds used on gas piping threaded joints should be resistant to action of liquefied petroleum gas.

#### **D-Testing Gas Piping**

When pressure testing gas lines, the gas valve must be disconnected and isolated. Gas valves can be damaged if subjected to more than 0.5psig (14" W.C.). See figure 44. If the pressure is equal to or less than 0.5psig (14"W.C.), use the manual shut-off valve before pressure testing to isolate furnace from gas supply.



**FIGURE 44**

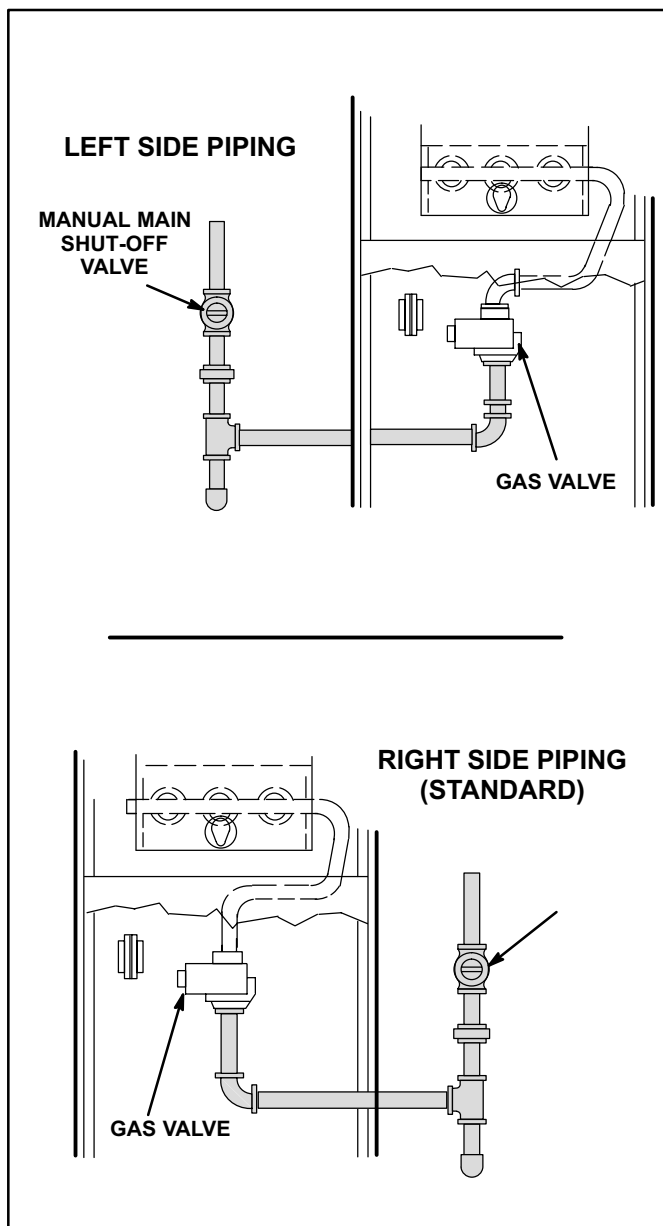


FIGURE 45

### ⚠ IMPORTANT

In case emergency shutdown is required, turn off the main shut-off valve and disconnect the main power to unit. These controls should be properly labeled by the installer.

When checking piping connections for gas leaks, use preferred means. Kitchen detergents can cause harmful corrosion on various metals used in gas piping. Use of a specialty Gas Leak Detector is strongly recommended. It is available through Lennox under part number 31B2001. See Corp. 8411-L10, for further details.

Do not use matches, candles, flame or any other source of ignition to check for gas leaks.

### E-Testing Gas Supply Pressure

When testing supply gas pressure, connect test gauge to inlet pressure tap (field provided). See figure 44. Check gas line pressure with unit firing at maximum rate. Low pressure may result in erratic operation or underfire. High pressure can result in permanent damage to gas valve or overfire. For natural gas units, operating pressure at unit gas connection must be between 4.5" W.C. and 13.0" W.C. For L.P. gas units, operating pressure at unit gas connection must be between 8.0" and 13.0" W.C.

On multiple unit installations, each unit should be checked separately, with and without units operating. Supply pressure must fall within range listed in previous paragraph.

### F-Check Manifold Pressure

Manifold *Operating* Pressure is the manifold pressure measured during normal operation (sensing burner box pressure). Manifold *Absolute* Pressure is the manifold pressure measured when the gas valve regulator is operating at factory preset level (sensing atmospheric pressure).

After line pressure has been checked and adjusted, check manifold absolute pressure. Move pressure gauge to outlet pressure tap located on unit gas valve (GV1). Checks of manifold absolute pressure are made as verification of proper regulator adjustment.

Manifold operating pressure for the G26 can be measured at any time the gas valve is open and is supplying gas to the unit. Normal manifold operating pressure for natural gas units is 2.5 to 3.5 in. w.c (see figure 21). For LP/propane gas the correct manifold operating pressure is 7.5 in. w.c. (see figure 22).

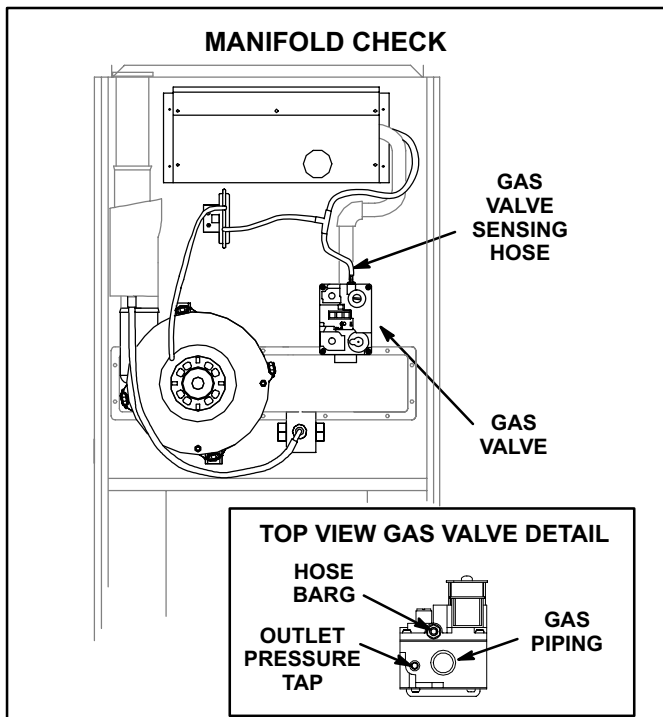
### ⚠ IMPORTANT

For safety, connect a shut-off valve between the manometer and the gas tap to permit shut off of gas pressure to the manometer.

The gas valve is factory set and should not require adjustment. See table 9. Also, gas valve regulation varies with burner box pressure (figures 21 and 22).

#### \*Manifold Absolute Pressure Measurement and Adjustment

- 1 - Connect test gauge to outlet tap on gas valve.
- 2 - Disconnect pressure sensing hose from gas valve and plug hose. Leave hose barb on valve open to atmosphere. See figure 46.
- 3 - Start unit and allow 5 minutes for unit to reach steady state.



**FIGURE 46**

- 4 - While waiting for the unit to stabilize, notice the flame. Flame should be stable and should not lift from burner. Natural gas should burn blue. L.P. gas should burn mostly blue with some orange streaks.
- 5 - After allowing unit to stabilize for 5 minutes, record manifold pressure and compare to values given in table 9. Regulator cap must be installed when reading pressures.

**TABLE 9**

<b>GAS VALVE REGULATION*</b>	
<b>Unit (Fuel)</b>	<b>Absolute Pressure (outlet) in. W.C.</b>
<b>Natural</b>	3.5 ±0.3
<b>L.P.</b>	7.5 ±0.7

*NOTE-Shut unit off and remove manometer as soon as an accurate reading has been obtained. Take care to replace pressure tap plug.*

*NOTE-During this test procedure, the unit will be overfiring:*

- Operate unit only long enough to obtain accurate reading to prevent overheating heat exchanger.
  - Attempts to clock gas valve during this procedure will be inaccurate. Measure gas flow rate only during normal unit operation.
- 6 - When test is complete remove obstruction from hose and return hose to gas valve barb.

## **⚠ WARNING**

**Fire and explosion hazard. These instructions MUST be followed exactly. Can cause a fire or explosion resulting in property damage, personal injury or loss of life.**

## **G- Proper Gas Flow (Approximate)**

Furnace should operate at least 5 minutes before checking gas flow. Determine time in seconds for **two** revolutions of gas through the meter. (Two revolutions assures a more accurate time.) Divide by two and compare to time in table 10 below. Adjust manifold pressure on gas valve to match time needed.

*NOTE- To obtain accurate reading, shut off all other gas appliances connected to meter.*

**TABLE 10**

<b>GAS METER CLOCKING CHART</b>				
<b>G26 Unit</b>	<b>Seconds for One Revolution</b>			
	<b>Natural</b>		<b>LP</b>	
	<b>1 cu ft Dial</b>	<b>2 cu ft Dial</b>	<b>1 cu ft Dial</b>	<b>2 cu ft DIAL</b>
-50	72	144	180	360
-75	48	96	120	240
-100	36	72	90	180
-125	29	58	72	144
Natural-1000 btu/cu ft		LP-2500 btu/cu ft		

## **H-High Altitude Derate**

Units are self-compensating for altitude and do not require kits or adjustment when installed below 7500 ft. elevation. Manifold pressure should remain the same for both natural and propane. If unit is installed at an altitude higher than 7500 feet (2248 m), refer to local codes.

*NOTE-This is the only permissible field derate for this appliance.*

## **⚠ IMPORTANT**

**For safety, shut unit off and remove manometer as soon as an accurate reading has been obtained. Take care to replace pressure tap plug.**

## **I-Flame Signal**

A 20 microamp DC meter is needed to check the flame signal on the SureLight and Johnson G776 ignition control. Use a flame signal transducer (part number 78H5401) available from Lennox to measure the flame signal.

Flame (microamp) signal is an electrical current which passes from the ignition control through the sensor electrode during unit operation. Current passes from the sensor through the flame to ground to complete a safety circuit.

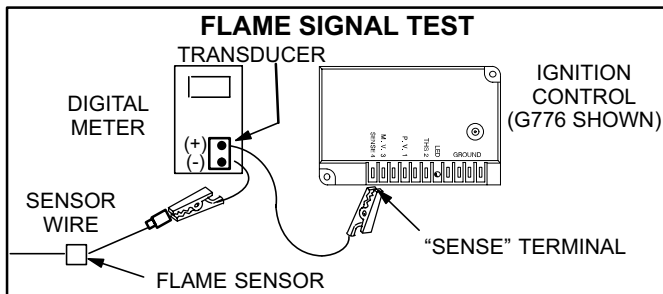
### **To Measure Flame Signal:**

- 1 - Set the volt meter to the DC voltage scale. Insert transducer into the VDC and common inputs. Observe correct polarities. Failure to do so results in negative (-) values.
- 2 - Turn off supply voltage to control.
- 3 - Disconnect flame sensor lead from terminal of ignition control.

- 4 - Connect (+) lead of transducer to ignition control sensor connection. See figure 47.
- 5 - Connect (-) lead of the transducer to sensor wire. See figure 47.
- 6 - Turn supply voltage on and close thermostat contacts to cycle system.
- 7 - When unit lights, read voltage on meter display. Remember 1 DC volt = 1 DC microamp.

**TABLE 11**

FLAME SIGNAL MICROAMPS		
G26 -1 and -2 models	Normal	0.25
	Minimum	0.15
G26 -3, -4, -5 and -6 models	Normal	> 0.7
	Low	≤ 0.7
	Minimum	0.15



**FIGURE 47**

## V-TYPICAL OPERATING CHARACTERISTICS

### A-Blower Operation and Adjustment

*NOTE- The following is a generalized procedure and does not apply to all thermostat controls.*

- 1 - Blower operation is dependent on thermostat control system.
- 2 - Generally, blower operation is set at thermostat sub-base fan switch. With fan switch in ON position, blower operates continuously. With fan switch in AUTO position, blower cycles with demand or runs continuously while heating or cooling circuit cycles.
- 3 - In all cases, blower and entire unit will be off when the system switch is in OFF position.

### B-Temperature Rise

Temperature rise for G26 units depends on unit input, blower speed, blower horsepower and static pressure as marked on the unit rating plate. The blower speed must be set for unit operation within the range of "AIR TEMP. RISE °F" listed on the unit rating plate.

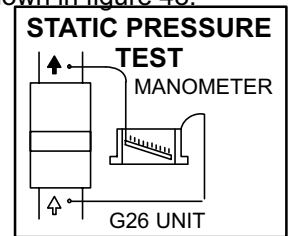
#### To Measure Temperature Rise:

- 1 - Place plenum thermometers in the supply and return air plenums. Locate supply air thermometer in the first horizontal run of the plenum where it will not pick up radiant heat from the heat exchanger.

- 2 - Set thermostat to highest setting.
- 3 - After plenum thermometers have reached their highest and steadiest readings, subtract the two readings. The difference should be in the range listed on the unit rating plate. If the temperature is too low, decrease blower speed. If temperature is too high, first check the firing rate. Provided the firing rate is acceptable, increase blower speed to reduce temperature. To change blower speed taps see the Blower Speed Taps section in this manual.

### C-External Static Pressure

- 1 - Measure tap locations as shown in figure 48.
- 2 - Punch a 1/4" diameter hole in supply upstream of evaporator and return air plenums. Insert manometer hose flush with inside edge of hole or insulation. Seal around the hose with per-magum. Connect the zero end of the manometer to the discharge (supply) side of the system. On ducted systems, connect the other end of manometer to the return duct as above. For systems with non-ducted returns, leave the other end of the manometer open to the atmosphere.
- 3 - With only the blower motor running and the evaporator coil dry, observe the manometer reading. Adjust blower motor speed to deliver the air desired according to the job requirements.
- 4 - Pressure drop must not exceed 0.5" W.C.
- 5 - Seal around the hole when the check is complete.



**FIGURE 48**

### D-Blower Speed Taps Leadless Motors -1, -2, -3 and -4 Models

Blower speed tap selection on unleaded motors is accomplished by changing the taps at the blower motor harness connector. Disconnect harness connector from motor to expose speed selectors. Blower speed selections are listed on table 12.

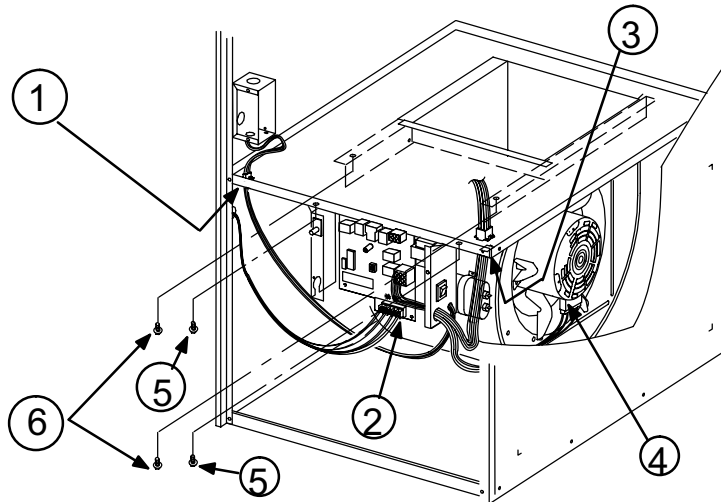
#### To Change Blower Speed Unleaded Motors

- 1 - Turn off electric power to furnace.
- 2 - Remove blower access door.
- 3 - Disconnect blower motor harness from motor.
- 4 - Pull harness connector and wires through blower access panel opening.
- 5 - Select desired speeds for heating and cooling. (Red = heating, Black = cooling, White = common).
- 6 - Depress harness connector tab to release wire terminal. Select connector location for new speed (refer to unit wiring diagram). Insert wire terminal until it is securely in place. See figure 50.
- 7 - Replace harness connector to motor .



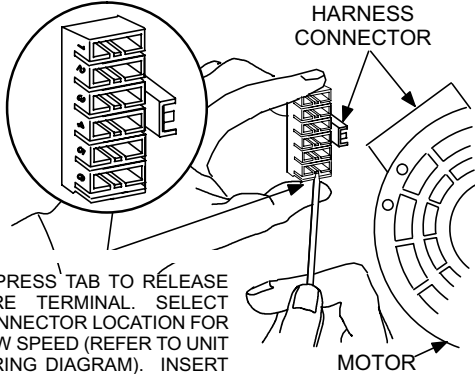
**To Remove Blower:**

- 1- Turn off line voltage power. Unplug J69 from P69 located on blower deck.
- 2- Disconnect thermostat wiring connections by removing low voltage terminal strip.
- 3- Disconnect J58/P58 located on blower deck.
- 4- Disconnect J43/P43 from blower motor.
- 5- Loosen screws (2) and remove control box from unit. Holes are slotted so screws do not need to be removed.
- 6- Remove screws (2) and remove blower from unit.



**FIGURE 49**

**BLOWER SPEED TAP SELECTION**



DEPRESS TAB TO RELEASE WIRE TERMINAL. SELECT CONNECTOR LOCATION FOR NEW SPEED (REFER TO UNIT WIRING DIAGRAM). INSERT WIRE UNTIL IT IS SECURELY IN PLACE.

**FIGURE 50**

**E-Blower Speed Taps Leaded Motors -5 and -6 Models**

Blower speed tap changes are made on the SureLight control board. See figure 10. Unused taps must be secured on dummy terminals "PARK M1" and or "PARK M2" on the SureLight board. The heating tap is connected to the "ACB HEAT" terminal and the cooling tap is connected to the "ACB COOL" terminal. The continuous blower tap is connected to the "ACB LOW" terminal.

To change existing heat tap, turn off power then switch out speed tap on "ACB HEAT" with tap connected to "PARK M1" or "PARK M2". See table 13 for blower motor tap colors for each speed.

**TABLE 12**

UNIT	FACTORY CONNECTED SPEED TAPS			MOTOR SPEEDS AVAILABLE
	COOL	HEAT	CONT	
Q2-50	2	3	4	3
Q3-50	2	4	5	4
Q3-75	2	3	5	4
Q4/5-75	2	5	6	5
Q3/4-100	2	4	5	4
Q3/4-125	2	3	5	4
Q4/5-100, 125	2	5	6	5

BLOWER SPEED SELECTION				
HI ← → LO				
SPEED TAPS	2	3	4	3
	2	3	4	5
	2	3	4	5

**TABLE 13**

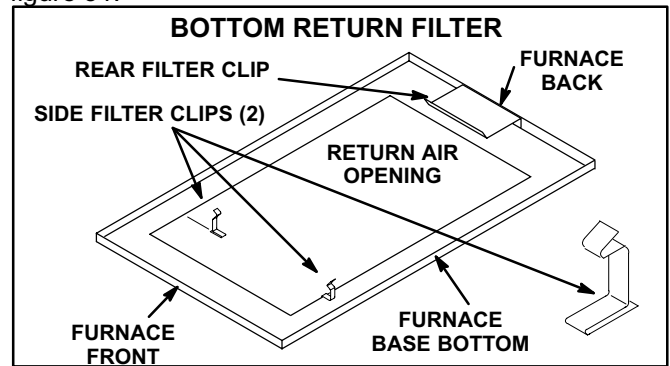
UNIT	FACTORY CONNECTED SPEED TAPS					MOTOR SPEEDS AVAILABLE
	COOL	HEAT	ACB LOW	M1	M2	
Q2-50	BLACK	YELLOW	RED	---	---	3
Q3-50	BLACK	YELLOW	RED	---	BROWN	4
Q3-75	BLACK	BROWN	RED	---	YELLOW	4
Q4/5-75	BLACK	YELLOW	RED	BROWN	BLUE	5
Q3/4-100	BLACK	YELLOW	RED	---	BROWN	4
Q3/4-125	BLACK	BROWN	RED	---	YELLOW	4
Q4/5-100, 125	BLACK	YELLOW	RED	BROWN	BLUE	5

BLOWER SPEED SELECTION				
HI ← → LO				
SPEED TAPS	BLACK	YELLOW	RED	3
	BLACK	BROWN	YELLOW	4
	BLACK	BROWN	BLUE	5

**VI-MAINTENANCE**

Retainers for factory supplied return air filter are shown in figure 51.



**FIGURE 51**

**A-Filters**

At the beginning of each heating season, the system should be checked as follows:

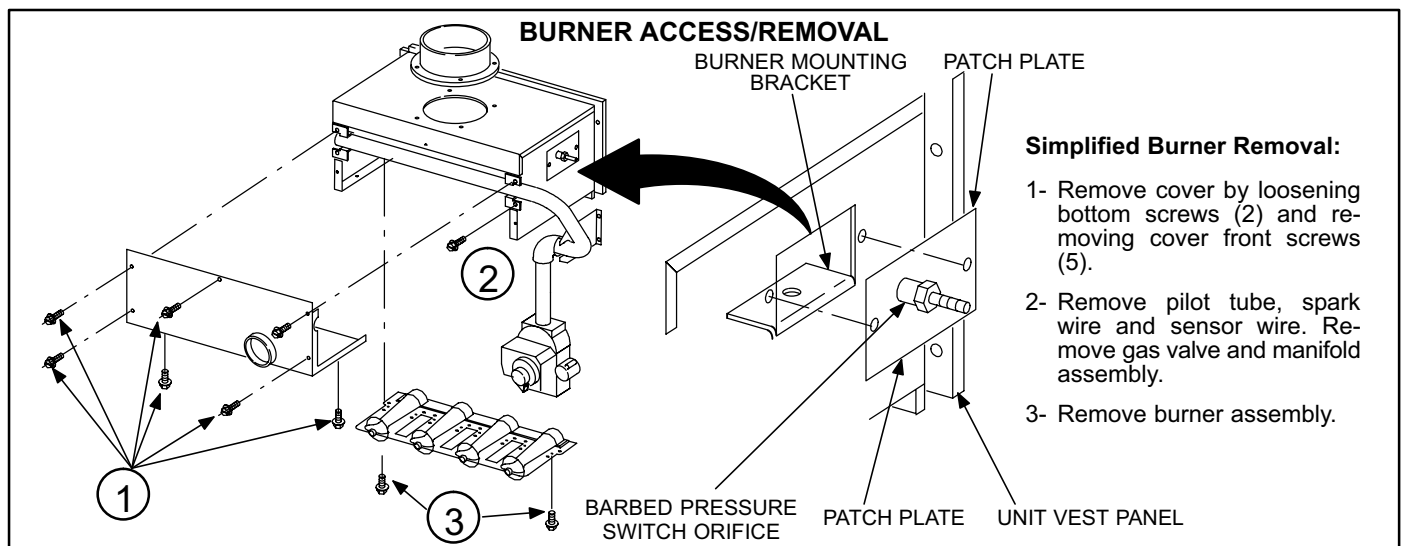
- 1- Filters should be inspected monthly and must be cleaned or replaced when dirty to ensure proper furnace operation.

- 2 - Reusable foam filters used with the G26 can be washed with water and mild detergent. When dry, they should be sprayed with filter handicoater prior to reinstallation. Filter handicoater is RP Products coating no. 418 and is available as Lennox part no. P-8-5069.
- 3 - If replacement is necessary, order Lennox part no. 31J81 for 14" x 25" (356 x 635mm) filter for G26-50 and -75 units and P-8-7831 for 20" x 25" (508 x 635mm) filter for G26Q4/5-75,G26-100 and -125 units.

## B-Cleaning Heat Exchanger and Burners

If cleaning the heat exchanger becomes necessary, follow the below procedures and refer to figure 1 when disassembling unit. Use papers or protective covering in front of furnace while removing heat exchanger assembly.

- 1 - Turn off electrical and gas power supplies to furnace.
- 2 - Remove upper and lower furnace access panels.
- 3 - Remove four (4) screws around air intake fitting and lift intake pipe up and away.
- 4 - Loosen hose clamp securing top of flue transition to bottom of flue collar. Remove screw securing flue collar to top cap and lift exhaust pipe and flue collar up and away.
- 5 - If electrical field make-up box is located inside the unit, it must be removed.
- 6 - Remove gas supply line connected to gas valve.
- 7 - Mark all gas valve wires and disconnect them from valve. Mark and remove wires from flame roll-out switch.
- 8 - Remove top cap of unit.
- 9 - For -1 and -2 units, mark and disconnect spark and sensor wire from ignition control. For -3 units, remove sensor wire from SureLight control. Disconnect 2-pin plug from the ignitor.
- 10 - Mark and disconnect pressure switch tubing from both sides of the pressure switch.
- 11 - Loosen two (2) screws holding gas manifold support at vestibule panel.
- 12 - Remove four (4) burner box screws at the vestibule panel and remove burner box and gas valve/manifold assembly with bracket.
- 13 - Drain condensate trap. Disconnect condensate line from the outside of unit. Remove condensate line from condensate trap by turning the adapter fitting counterclockwise. The fitting has standard right hand threads.
- 14 - Disconnect the drain hose from the flue transition to the elbow on the cold header (collector) box trap. On -1 and -2 units remove two (2) screw from flue "Y" trap at cabinet from door flange.
- 15 - Disconnect the 2-pin plug from the combustion air blower at the blower deck. Remove four (4) screws from combustion air blower and remove flue transition and blower assembly from cabinet. Take care not to lose the combustion air orifice.
- 16 - Disconnect 9-pin plug from the blower compartment at the blower deck.
- 17 - Remove 9-pin plug above the blower deck.
- 18 - Remove the limit switch and the pressure switch from the vestibule panel.
- 19 - Remove two (2) screws from the front cabinet flange at the blower deck. Remove front screws from cabinet at blower deck on left and right sides. Cabinet sides must be slightly spread to clear heat exchanger passage.
- 20 - Remove screws along vestibule sides and bottom which secure vestibule panel and heat exchanger assembly to cabinet. Remove heat exchanger then remove cold end header box.
- 21 - Back wash heat exchanger with soapy water solution or steam. **If steam is used it must be below 275°F (135°C)**.
- 22 - Thoroughly rinse and drain the heat exchanger. Soap solution can be corrosive so take care that entire assembly is completely rinsed.
- 23 - Re-install heat exchanger into cabinet making sure that the clamshells of the heat exchanger assembly are resting in the notches of the support located at the rear of the cabinet. This can be viewed by removing the indoor blower and examining through the blower opening.
- 24 - Re-secure the supporting screws along the vestibule sides and bottom to the cabinet.
- 25 - Re-install cabinet screws on sides and front flange at blower deck.
- 26 - Re-install the limit switch and pressure switch on the vestibule panel.
- 27 - Re-install 9-pin plug to blower deck and connect it to the 9-pin plug from below the blower deck.
- 28 - Re-install the combustion air blower. Be careful that the plastic orifice on the blower inlet has not fallen out. See figure 1. Reconnect the 2-pin plug to the wire harness. Re-install the flue transition in the cabinet and re-attach the drain tube. Route the drain tube below the combustion air blower housing and to the elbow on the cold header (collector) box trap. See figure 23.
- 29 - Re-install condensate line with adapter to condensate trap. Use fresh Teflon tape to ensure a leak-free joint. Re-connect to condensate line outside of the unit.



**FIGURE 52**

- 30- Re-install the burner box. Tighten the screws holding the support bracket. It is important that the glass fiber gasket not be damaged so it will provide a continuous seal between the burner box and the vestibule panel.
- 31- With the pressure switch oriented on the right, reconnect pressure switch tubing by connecting the tubing from the burner box to the barb on the bottom and the tubing from the combustion air blower to the barb on the top. See figure 23.
- 32- Reconnect the sensor and ignitor wires.
- 33- Re-install top cap to unit.
- 34- Re-install electrical connections to gas valve. Orange wire to M1 and yellow wire to C2. Reconnect wires to flame roll-out switch.  
*NOTE - Unit is polarity-sensitive. 120V supply wiring must be installed correctly.*
- 35- Reconnect main gas line to gas valve.
- 36- Re-install field make-up box if removed.
- 37- Re-install exhaust pipe/flue collar and secure flue collar to the unit top cap using existing screw. Insert the bottom of the flue collar into the top of the flue transition and tighten hose clamp.
- 38- Re-install intake pipe fitting to burner box with screws.
- 39- Replace both upper and lower access panels.
- 40- Refer to instruction on verifying gas and electrical connections when re-establishing supply.
- 41- Following lighting instructions from installation manual, light and run unit for 5 minutes to ensure heat exchanger is clean, dry and operating safely.

### **Cleaning the Burner Assembly**

- 1 - Turn off electrical and gas power supplies to furnace. Remove upper and lower furnace access panels.
- 2 - Disconnect the gas supply line to gas valve. Depending on gas plumbing installation, the gas manifold may move aside enough that breaking the union may not be necessary.
- 3 - Remove five (5) screws from edges of burner box cover. G26-50 units have only four (4) screws.
- 4 - Loosen two (2) screws on bottom of burner box front. The cover is key holed at these screw point so screws do not need to be removed. Pull off cover and set aside.
- 6 - On -1 and -2 units disconnect pilot line at the gas valve. On all units mark all gas valve wires and disconnect them from valve.
- 7 - ON -1 and -2 units mark and disconnect spark and sensor wire from the burner box at the ignition control. On -3 mark and disconnect sensor wires from the burner box at the SureLight control. Disconnect 2-pin plug from the ignitor at the burner box.
- 8 - Loosen two (2) screws at the gas manifold support bracket.
- 9 - Pull on the left side of the gas manifold and follow with tension to the right side. The manifold support bracket will be free of the mounting screws on the vestibule panel. Set the gas manifold/gas valve assembly aside. Take care not to damage foam gaskets on each end of the gas manifold.
- 10- Using a 1/4" nut driver, remove the burner mounting screws from underneath the burners.

- 11- While supporting pilot, ignitor and sensor wires (-1,-2 units) or ignitor and sensor lines (-3 units) at the grommet, grasp burners and simultaneously pull burners and grommet out of the burner box.
- 12- Remove ignitor and sensor or pilot bracket assemblies from burners using a 1/4" nut driver to remove two screws from each bracket.
- 13- Clean burner by running a vacuum with a soft brush attachment over face of burners. Visually inspect inside of burners and crossovers for any blockage caused by foreign matter. Remove any blockage.
- 14- Re-install ignitor and sensor bracket assemblies on burners.

*NOTE - Ignitor or pilot must be installed on the opposite side of the burner from the metal button protrusions. Screws which attached the ignitor bracket must be installed from the same side as the ignitor and through the bracket to engage in the smaller holes located in the burner. The correct burner orientation is with metal button protrusions always pointing up.*

- 15- Replace burner ignitor assembly back into burner box so that grommet groove fits back into sheet metal notch and makes a good seal. The burners sit on top of the burner box flanges. Make certain that the screws from underneath the box pass through the larger holes in the flange and engage in the smaller holes in the burner. Re-install the two screws.
- 16- Re-install the gas manifold/gas valve assembly by first inserting the right hand side of the gas manifold into the burner box. Swing left side of manifold into box while engaging support bracket to vestibule panel screws. Check that foam gaskets are providing a seal around each end of the gas manifold. All gas orifices should be engaged. If at this point the burners were mounted in the wrong holes, this needs to be corrected. The saddle brackets on the gas manifold should be flush with the front surfaces on the burner box sides.
- 17- Inspect the dual layered metal pieces at the front lip of the cover. These pieces must sandwich around the metal. Re-install burner box cover.
- 18- Re-install the screws to secure the burner box cover. Make sure screws are tight to ensure a leak tight burner box. Tighten the two screws underneath the box. Again, inspect the grommet to ensure a tight seal.
- 19- Tighten the two screws holding the manifold bracket

to the vestibule panel.

- 20- Re-install the electrical connections to the gas valve. Orange wire to M1 and yellow wire to C2.
- 21- On -1 and -2 units re-install the spark wire (larger of the two) to the barbed connector at the ignition control. Re-install the sensor wire to the spade connector on the ignition control. On -3 units re-install the 2-pin ignitor plug at the burner box. Re-install sensor line to ignition control spade connector.
- 22- Reconnect gas line to gas valve. On -1 and -2 units reconnect pilot line to gas valve.
- 23- Replace lower access panel.
- 24- Following lighting instructions and gas line connection test procedures from installation manual.
- 25- Replace upper access panel.

### **C-Supply Air Blower**

- 1 - Check and clean blower housing and blower wheel.
- 2 - Motors are prelubricated for extended life; no further lubrication is required.

### **D-Electrical**

- 1 - Check all wiring for loose connections.
- 2 - Check circuit breaker located in unit control box.
- 3 - Check for correct voltage at unit (unit operating).
- 4 - Check amp-draw on blower motor.  
Motor Nameplate \_\_\_\_\_ Actual \_\_\_\_\_
- 5 - Check to see that heat (if applicable) is operating.

### **E-Intake and Exhaust Lines**

Check intake and exhaust lines and all connections for tightness and make sure there is no blockage. Also check condensate line for free flow during operation.

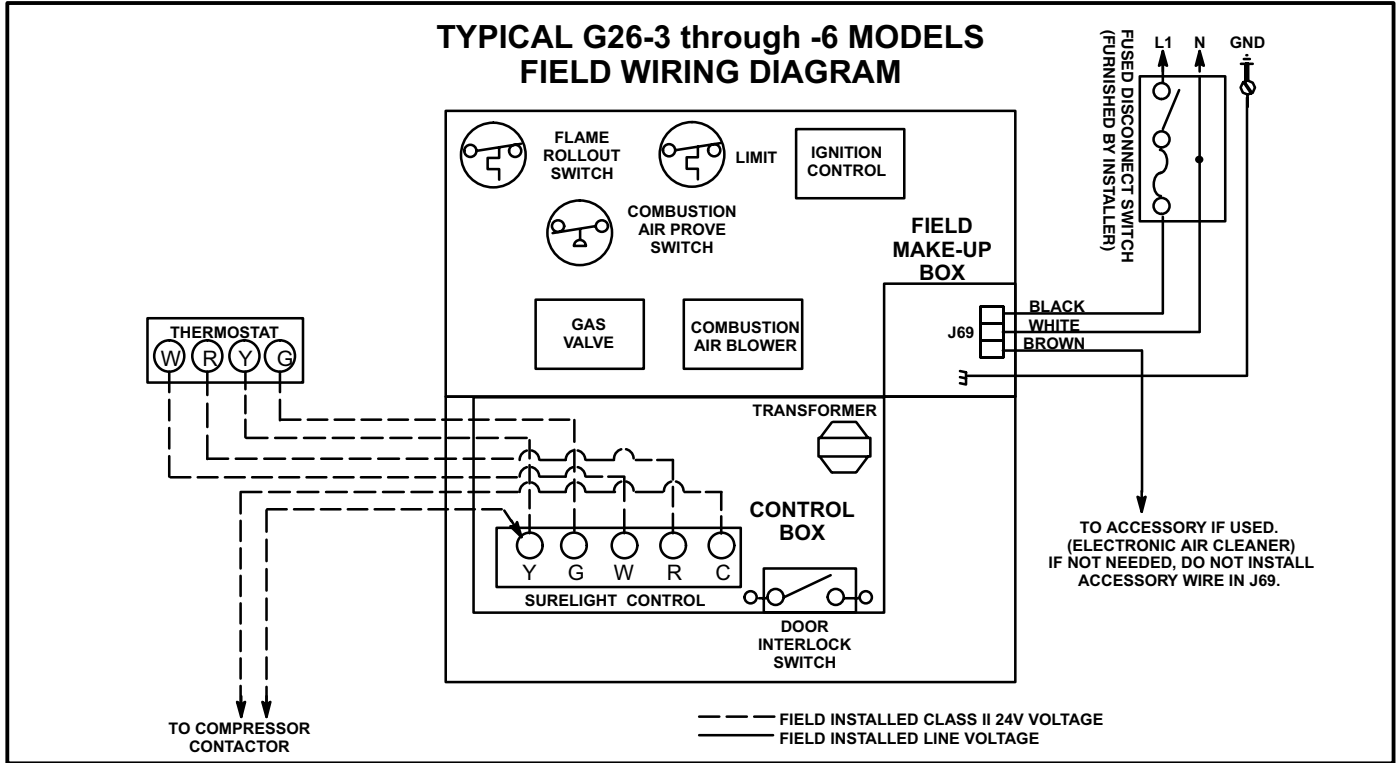
### **F-Insulation**

Outdoor piping insulation should be inspected yearly for deterioration. If necessary, replace with same materials.

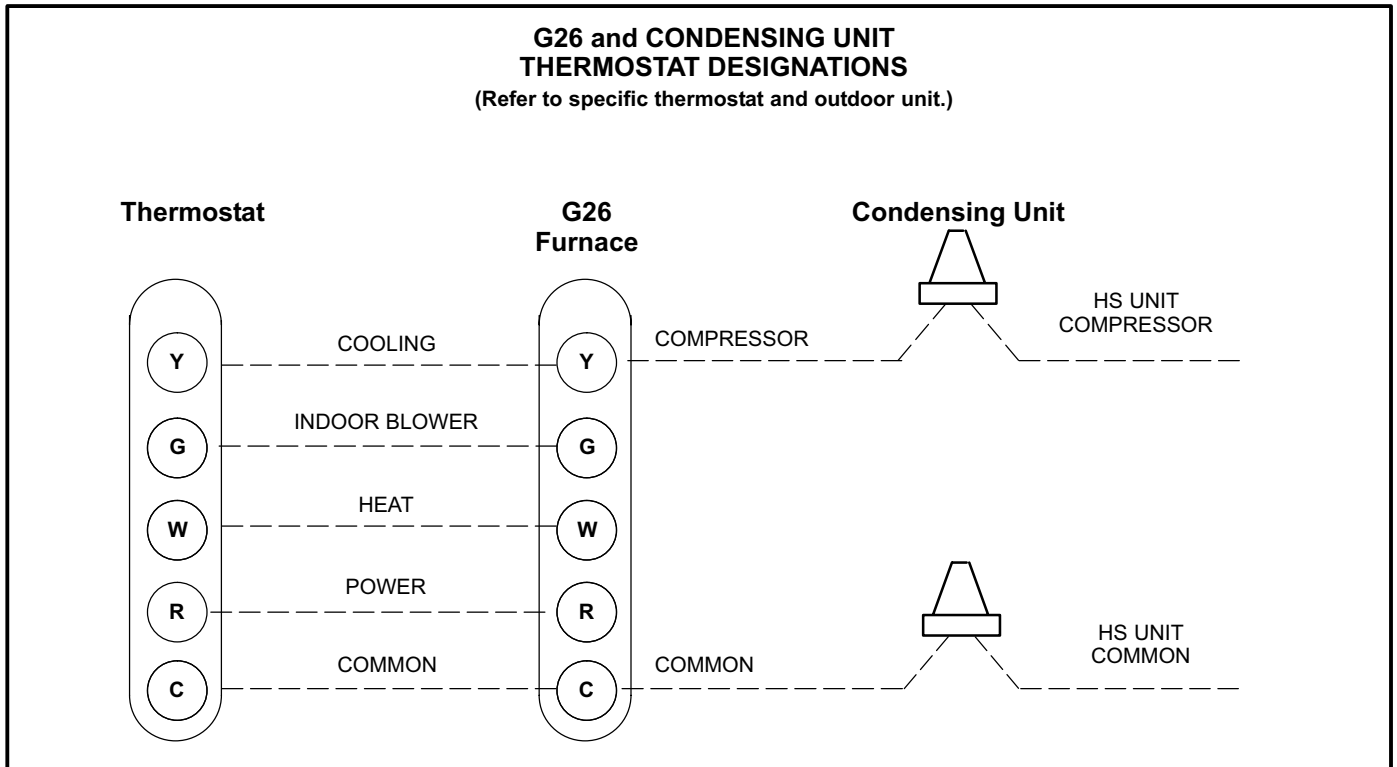
### **G-Winterizing and Condensate Trap Care**

- 1 - Turn off power to unit.
- 2 - Have a shallow pan ready to empty condensate water. Avoid spilling water into the control box.
- 3 - Remove clamp from flue assembly and remove boot or cap. Empty water from cap. Visually inspect bottom of flue assembly. Replace boot and clamp.
- 4 - Remove boot from condensate trap and empty water. Inspect trap then replace boot.

**VII-WIRING DIAGRAM, SEQUENCE OF OPERATION & TROUBLESHOOTING**  
**A-Field Wiring, Thermostat Connections**

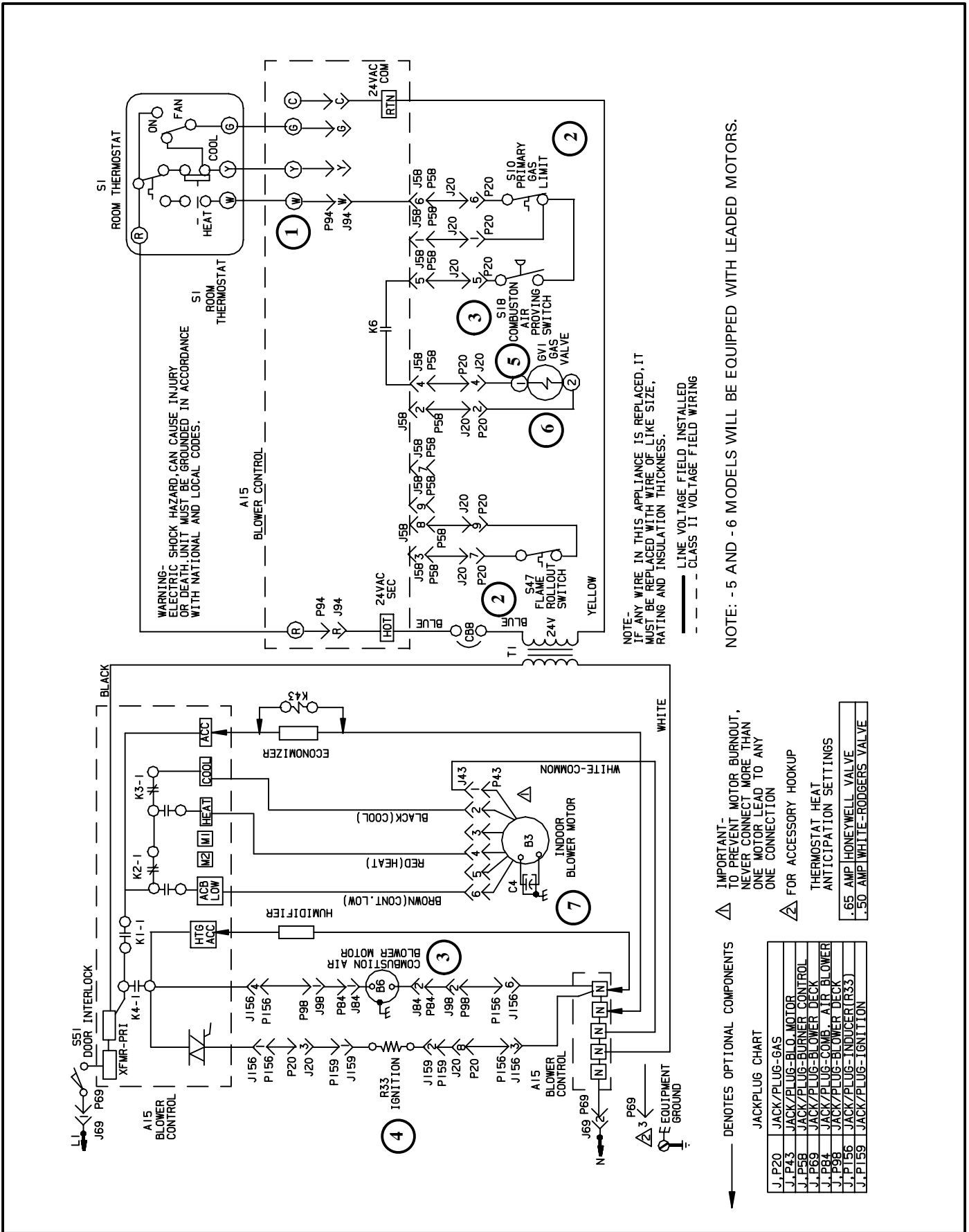


**FIGURE 53**



**FIGURE 54**

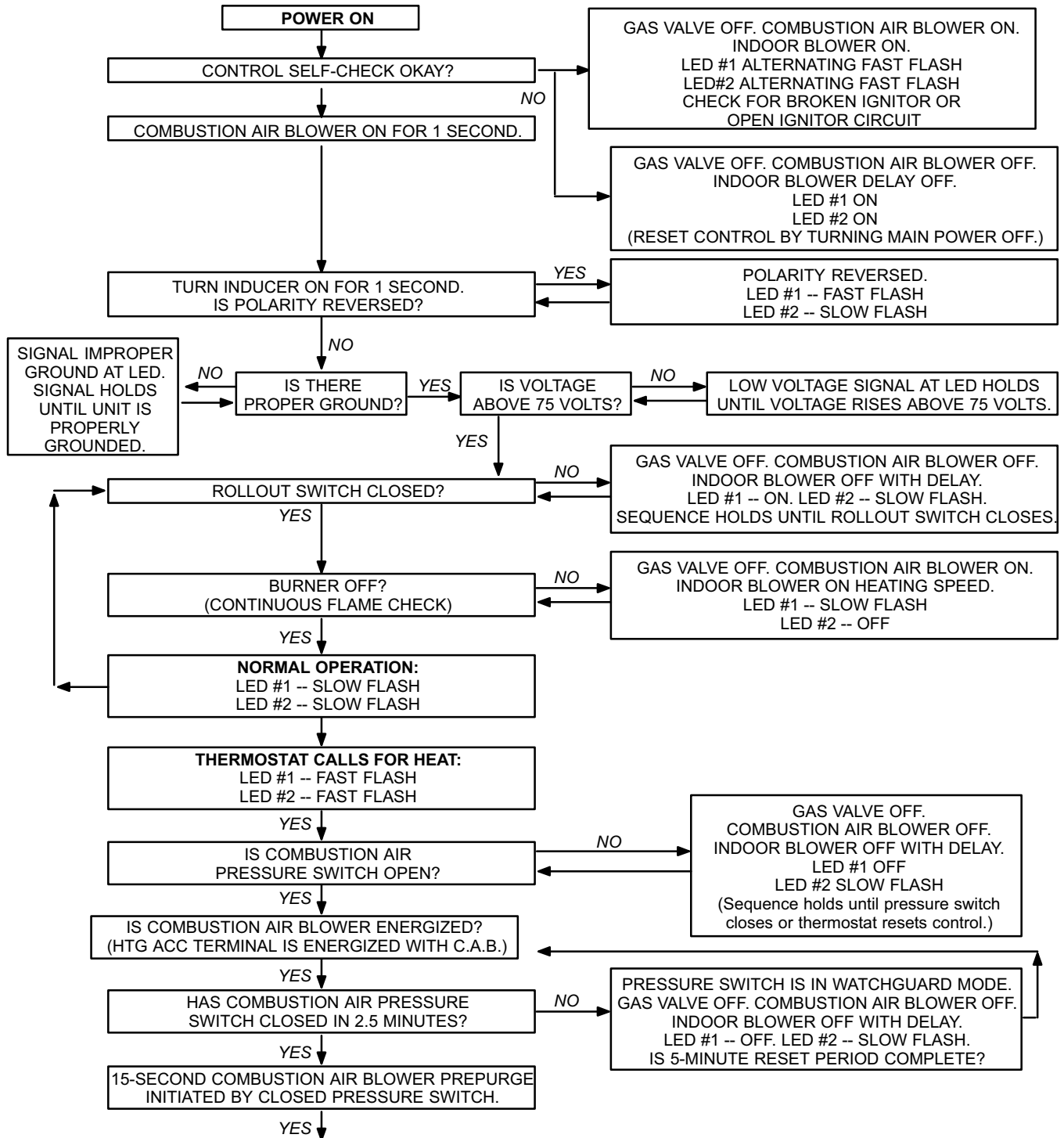
# B-Wiring Diagram G26 (-3 & -4 Shown)



## HEATING SEQUENCE OF OPERATION SURELIGHT CONTROL

### NORMAL HEATING MODE

### ABNORMAL HEATING MODE



CONTINUED NEXT PAGE

## HEATING SEQUENCE CONTINUED

### NORMAL HEATING MODE

### ABNORMAL HEATING MODE

15-SECOND COMBUSTION AIR BLOWER PREPURGE INITIATED BY CLOSED PRESSURE SWITCH.

YES

IGNITOR WARM-UP -- 20 SECONDS.

YES

4-SECOND TRIAL FOR IGNITION. GAS VALVE OPENS. IGNITOR ENERGIZED FOR 1 SECOND AFTER VALVE OPENS. BOARD 97L48 ONLY: IGNITOR ENERGIZED FOR FULL 4-SECOND IGNITION TRIAL.

YES

FLAME STABILIZATION PERIOD.

4 SECONDS

FLAME RECTIFICATION CURRENT CHECK  
CAN FLAME BE PROVEN WITHIN 4 SECONDS AFTER GAS VALVE OPENS?  
( > 0.15 microamps)

FLAME PRESENT?

YES

FLAME SIGNAL ABOVE 0.7 MICROAMPS?

YES

INDOOR BLOWER ON DELAY BEGINS. AFTER 45 SECOND DELAY, ACB HEAT SPEED AND ACC TERMINAL IS ENERGIZED.

YES

PRIMARY AND SECONDARY LIMIT SWITCHES CLOSED?

YES

ROLLOUT SWITCH CLOSED?

YES

COMBUSTION AIR PRESSURE SWITCH CLOSED?

YES

THERMOSTAT DEMAND SATISFIED.

YES

LED #1 & #2 SIMULTANEOUS SLOW FLASHES.

YES

COMB. AIR BLOWER CONTINUES 5-SECOND POST PURGE AFTER T'STAT DEMAND IS SATISFIED. INDOOR AIR BLOWER COMPLETES SELECTED "OFF" DELAY BEFORE SHUTTING OFF. ACB HEAT, HTG ACC AND ACC TERMINALS DE-ENERGIZED.

NO

GAS VALVE OFF. COMBUSTION AIR BLOWER ON. INDOOR BLOWER OFF.  
HAS CONTROL FAILED TO SENSE FLAME FOR FIVE CONSECUTIVE TRIES DURING A SINGLE HEAT DEMAND?

YES

WATCHGUARD MODE. GAS VALVE OFF. COMBUSTION AIR BLOWER OFF. INDOOR BLOWER OFF WITH DELAY  
LEDs SIGNAL WATCHGUARD FAILURE CODE. IS 60-MINUTE RESET PERIOD COMPLETE?

NO

YES

NO

HAS CONTROL RESET IGNITION SEQUENCE FOUR TIMES?

YES

NO

NO

LOW FLAME SIGNAL  
(Does not affect operation of control)  
LED #1 -- SLOW FLASH  
LED #2 -- FAST FLASH

NO

GAS VALVE DE-ENERGIZED. COMBUSTION AIR BLOWER DE-ENERGIZED. INDOOR BLOWER ON UNTIL SWITCH CLOSSES.  
LED #1 -- SLOW FLASH. LED #2 -- ON.  
IS LIMIT SWITCH CLOSED?

YES

NO

HAS PRIMARY/SECONDARY LIMIT RESET?  
(See table 2 DIAGNOSTIC CODES for limit reset operation)

NO

YES

NO

GAS VALVE OFF. COMBUSTION AIR BLOWER OFF. INDOOR BLOWER OFF WITH DELAY.  
LED #1 -- ON. LED #2 -- SLOW FLASH.  
SEQUENCE HOLDS UNTIL ROLLOUT SWITCH CLOSSES.

NO

GAS VALVE DE-ENERGIZED. COMBUSTION AIR BLOWER ON. INDOOR BLOWER OFF WITH DELAY  
LED #1 -- OFF. LED #2 -- SLOW FLASH.  
HAS CAB SWITCH CLOSED IN 2.5 MINUTES?

YES

NO

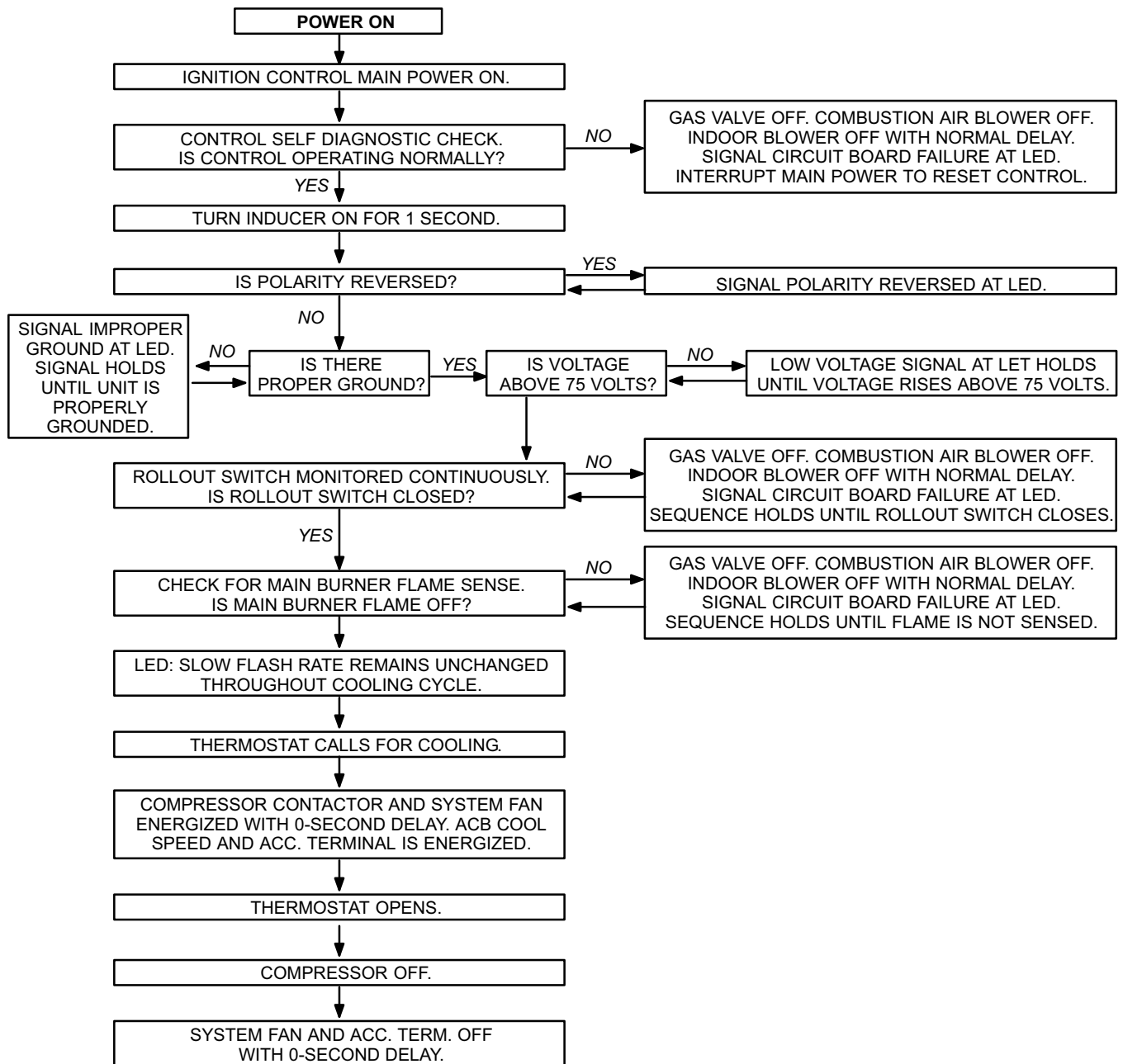
5-MINUTE PRESSURE SWITCH WATCHGUARD MODE.



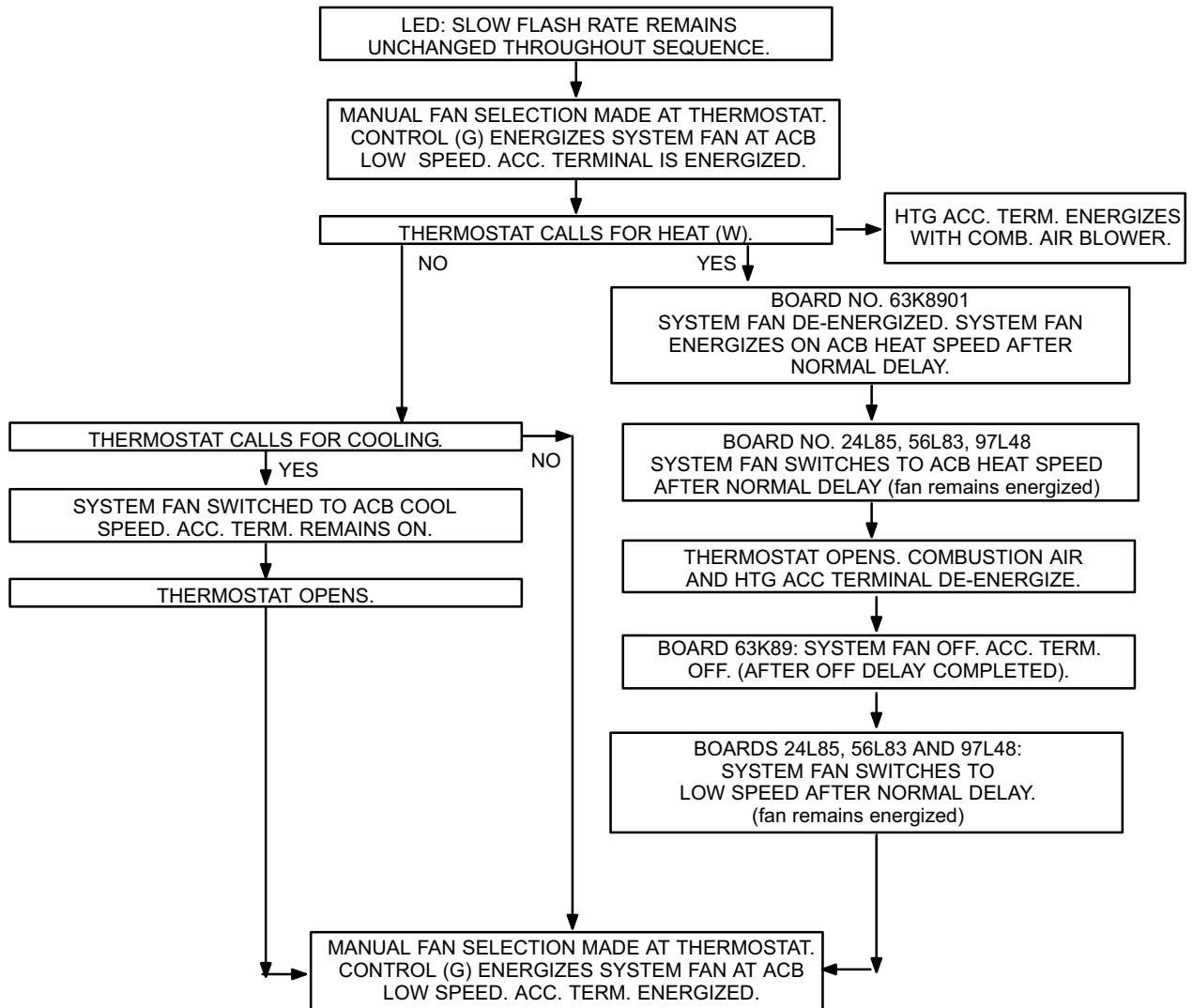
## COOLING SEQUENCE OF OPERATION SURELIGHT CONTROL

### NORMAL COOLING MODE

### ABNORMAL COOLING MODE



## CONTINUOUS LOW SPEED FAN SEQUENCE OF OPERATION SURELIGHT CONTROL



### C-Heating Sequence of Operation

- 1 - When there is a call for heat, W1 of the thermostat energizes W of the furnace control with 24VAC.
- 2 - S10 primary limit switch and S47 rollout switch are closed. Call for heat can continue.
- 3 - Surelight control energizes combustion air blower B6. Combustion air blower runs until S18 combustion air prove switch closes (switch must close within 2-1/2 minutes or control goes into 5 minute Watchguard Pressure Switch delay). Once S18 closes, a 15-second pre-purge follows.
- 4 - Surelight control energizes ignitor. A 20-second warm-up period begins.
- 5 - Gas valve opens for a 4-second trial for ignition.
- 6 - Flame is sensed, gas valve remains open for the heat call.
- 7 - After 45-second delay, Surelight control energizes indoor blower B3.
- 8 - When heat demand is satisfied, W1 of the indoor thermostat de-energizes W of the Surelight control which de-energizes the gas valve. Combustion air blower B6 continues a 5-second post-purge period, and indoor blower B3 completes a selected OFF time delay.

## D- SureLight Control Trouble Shooting Guide

UPON INITIAL POWER UP, REMOVE ALL THERMOSTAT DEMANDS TO THE UNIT

<b>PROBLEM: 1 UNIT FAILS TO OPERATE IN THE COOLING, HEATING, OR CONTINUOUS FAN MODE</b>		
<b>Condition</b>	<b>Possible Cause</b>	<b>Corrective Action / Comments</b>
<p><b>1.1</b></p> <p>- Both diagnostic lights fail to light up.</p> <p>LED#1-Off LED#2-Off</p>	<p><b>1.1.1</b></p> <p>Main voltage 120V not supplied to unit.</p>	<p><b>ACTION 1</b> - Check 120V main voltage. Determine cause of main power failure.</p>
	<p><b>1.1.2</b></p> <p>Miswiring of furnace or improper connections.</p>	<p><b>ACTION 1</b> - Check for correct wiring of 120V to power make up box and transformer. <b>ACTION 2</b> - Check 24V wiring to control board.</p>
	<p><b>1.1.3</b></p> <p>Circuit breaker tripped or fails to close.</p>	<p><b>ACTION 1</b> - Replace circuit breaker if it is reset but does not have continuity. <b>ACTION 2</b> - If circuit breaker still trips, check for short.</p>
	<p><b>1.1.4</b></p> <p>Door interlock switch failure.</p>	<p><b>ACTION 1</b> - Check that door switch is activated when door is closed. <b>ACTION 2</b> - Check wire connections to switch, replace loose connectors. <b>ACTION 3</b> - Check continuity of switch in closed position. Replace if malfunctioning</p>
	<p><b>1.1.5</b></p> <p>Transformer Failure.</p>	<p><b>ACTION 1</b> - Check that transformer output is 24V. Replace if malfunctioning</p>
	<p><b>1.1.6</b></p> <p>Failed control board.</p>	<p><b>ACTION 1</b> - If all the above items have been checked, replace board.</p>
<p><b>1.2</b></p> <p>- Diagnostic lights flash the roll-out code.</p> <p>LED#1-On, LED#2-Slow Flash</p>	<p><b>1.2.1</b></p> <p>Roll-out switch open.</p>	<p><b>ACTION 1</b> - Manually reset the roll-out switch by pushing the top button. <b>ACTION 2</b> - Determine the cause of the roll-out switch activation before leaving furnace.</p>
	<p><b>1.2.2</b></p> <p>Roll-out switch failure.</p>	<p><b>ACTION 1</b> - Check continuity across roll-out switch. Replace roll-out switch if switch is reset but does not have continuity.</p>
	<p><b>1.2.3</b></p> <p>Miswiring or improper connections at roll-out switch.</p>	<p><b>ACTION 1</b> - Check wiring connections to switch.</p>
	<p><b>1.2.4</b></p> <p>Nine pin connector failure</p>	<p><b>ACTION 1</b> - Check 9-pin connector for proper connection to control board. <b>ACTION 2</b> - Check continuity of the multi plug pin.</p>
<p><b>1.3</b></p> <p>- On initial power-up the comb. air blower does not energize. - Diagnostic lights flash the reverse polarity code.</p> <p>LED#1-Fast Flash, LED#2-Slow Flash.</p>	<p><b>1.3.1</b></p> <p>120V main power polarity reversed.</p>	<p><b>ACTION 1</b> - Check the 120V has line and neutral correctly input into control. <b>ACTION 2</b> - Reverse the line and neutral at the 120V field connection.</p>
<p><b>1.4</b></p> <p>- On initial power up the combustion air blower does not energize. - Diagnostic lights flash normal power on operation.</p> <p>LED#1-Slow Flash LED#2-Slow Flash</p>	<p><b>1.4.1</b></p> <p>Open combustion air blower motor circuit.</p>	<p><b>ACTION 1</b> - Check for 120V to combustion air blower. If no power, check wire and connections.</p>
	<p><b>1.4.2</b></p> <p>Failed combustion air blower motor.</p>	<p><b>ACTION 1</b> - If power is present at blower, replace blower.</p>

**PROBLEM 1: UNIT FAILS TO OPERATE IN THE COOLING, HEATING, OR CONTINUOUS FAN MODE**

Condition	Possible Cause	Corrective Action / Comments
<p><b>1.5</b></p> <ul style="list-style-type: none"> <li>- On initial power-up the combustion air blower remains energized.</li> <li>- Diagnostic lights flash the improper main ground.</li> </ul> <p>LED#1-Alternating Fast Flash LED#2-Alternating Fast Flash</p>	<p><b>1.5.1</b></p> <p>Improper ground to the unit.</p>	<p><b>ACTION 1</b> - Check that the unit is properly ground. <b>ACTION 2</b> - Install a proper main ground to the unit</p>
	<p><b>1.5.2</b></p> <p>6-Pin connector is improperly attached to the circuit board.</p>	<p><b>ACTION 1</b> - Check 6-pin connector for proper installation. Correctly insert connector into control.</p>
	<p><b>1.5.3</b></p> <p>Line voltage is below 75V.</p>	<p><b>ACTION 1</b> - Check that the line voltage is above 75V. Determine cause of voltage drop and supply correct voltage to the control.</p>

**PROBLEM 2: UNIT FAILS TO OPERATE IN THE COOLING OR HEATING MODE, BUT COMBUSTION AIR BLOWER OPERATES CONTINUOUS. UNITS WITH CONTROL BOARDS DATE CODED AFTER NOV.1 1997, WILL OPERATE IN COOLING BUT NOT IN THE HEATING MODE, WITH COMBUSTION AIR BLOWER CYCLING 5 SECONDS ON 55 SECONDS OFF.**

Condition	Possible Cause	Corrective Action / Comments
<p><b>2.1</b></p> <ul style="list-style-type: none"> <li>- On initial power-up the combustion air blower remains energized.</li> <li>- Diagnostic lights flash the improper main ground.</li> <li>- Units with control boards date coded after Nov.1 1997; combustion air blower will cycle 5 seconds on 55 seconds off.</li> </ul> <p>LED#1-Alternating Fast Flash LED#2-Alternating Fast Flash</p>	<p><b>2.1.1</b></p> <p>Open ignitor circuit.</p>	<p><b>ACTION 1</b> - Check for correct wiring and loose connections in the ignitor circuit. Check multi-plug connections for correct installation.</p>
	<p><b>2.1.2</b></p> <p>Broken or failed ignitor.</p>	<p><b>ACTION 1</b> - Unplug ignitor and read resistance across ignitor. If resistance does not read between 10.9 and 19.7 ohms, replace the ignitor.</p>

**PROBLEM 3: UNIT FAILS TO FIRE IN THE HEATING MODE, COMBUSTION AIR BLOWER DOES NOT ENERGIZE**

Condition	Possible Cause	Corrective Action / Comments
<p><b>3.1</b></p> <ul style="list-style-type: none"> <li>- Unit operates with a cooling or continuous fan demand.</li> <li>- Combustion air blower will not start with a Heating demand.</li> <li>- Diagnostic lights flash the limit failure mode.</li> </ul> <p>LED#1-Slow Flash, LED#2-On</p>	<p><b>3.1.1</b></p> <p>Primary or secondary (if equipped) limit open.</p>	<p><b>ACTION 1</b> - Check continuity across switch(es). Switches reset automatically upon cool down. <b>ACTION 2</b>-Check for restrictions on blower inlet air (including filter) and outlet air. Determine cause for limit activation before placing unit back in operation.</p>
	<p><b>3.1.2</b></p> <p>Miswiring of furnace or improper connections at limit switch(es).</p>	<p><b>ACTION 1</b> - Check for correct wiring and loose connections. Correct wiring and/or replace any loose connections.</p>
<p><b>3.2</b></p> <ul style="list-style-type: none"> <li>- Unit operates with a cooling and continuous fan demand.</li> <li>- Combustion air blower will not start with a Heating demand.</li> <li>- Diagnostic lights flash the pressure switch failure code.</li> </ul> <p>LED#1-Off, LED#2-Slow Flash</p>	<p><b>3.2.1</b></p> <p>Miswiring of furnace or improper connections to combustion air blower.</p>	<p><b>ACTION 1</b> - Check for correct wiring and loose connections. Correct wiring and/or replace any loose connections.</p>
	<p><b>3.2.2</b></p> <p>Pressure switch stuck closed.</p>	<p><b>ACTION 1</b> - Check that the pressure switch is open without the combustion air blower operating. Replace if malfunctioning</p>

**PROBLEM 3: UNIT FAILS TO FIRE IN THE HEATING MODE, COMBUSTION AIR BLOWER DOES NOT ENERGIZE (CONT.).**

Condition	Possible Cause	Corrective Action/Comments
<b>3.3</b> - Unit operates with a cooling and continuous fan demand. - Combustion air blower will not start with a Heating demand. - Diagnostic lights flash the pressure switch failure code 2.5 minutes after heating demand.  LED#1-Off, LED#2-Slow Flash	<b>3.3.1</b> Miswiring of furnace or improper connections to combustion air blower.	<b>ACTION 1</b> - Check for correct wiring and loose connections. Correct wiring and/or replace any loose connections.
	<b>3.3.2</b> Combustion air blower failure.	<b>ACTION 1</b> - If there is 120V to combustion air blower and it does not operate, replace combustion air blower.

**PROBLEM 4: UNIT FAILS TO FIRE IN THE HEATING MODE, COMBUSTION AIR BLOWER ENERGIZES, IGNITOR IS NOT ENERGIZED.**

Condition	Possible Cause	Corrective Action/Comments
<b>4.1</b> - Unit operates with a cooling and continuous fan demand. - Combustion air blower energizes with a heating demand. - Diagnostic lights flash the pressure switch failure code 2.5 minutes after heating demand.  LED#1-Off LED#2-Slow Flash	<b>4.1.1</b> Pressure switch does not close due to incorrect routing of the pressure switch lines.	<b>ACTION 1</b> - Check that the pressure switch lines are correctly routed. Correctly route pressure switch lines.
	<b>4.1.2</b> Pressure switch does not close due to obstructions in the pressure lines.	<b>ACTION 1</b> - Remove any obstructions from the the pressure lines and/or taps.
	<b>4.1.3</b> Pressure switch lines damaged	<b>ACTION 1</b> - Check pressure switch lines for leaks. Replace any broken lines.
	<b>4.1.4</b> Condensate in pressure switch line.	<b>ACTION 1</b> - Check pressure switch lines for condensate. Remove condensate from lines. Check that the condensate lines are located correctly.
	<b>4.1.5</b> Pressure switch does not close due to a low differential pressure across the pressure switch.	<b>ACTION 1</b> - Check the differential pressure across the pressure switch. This pressure should exceed the set point listed on the switch. <b>ACTION 2</b> - Check for restricted inlet and exhaust vent. Remove all blockage. <b>ACTION 3</b> - Check for proper vent sizing and run length. See installation instructions.
	<b>4.1.6</b> Wrong pressure switch installed in the unit, or pressure switch is out of calibration.	<b>ACTION 1</b> - Check that the proper pressure switch is installed in the unit. Replace pressure switch if necessary.
	<b>4.1.7</b> Miswiring of furnace or improper connections at pressure switch.	<b>ACTION 1</b> - Check for correct wiring and loose connections. Correct wiring and/or replace any loose connections.
	<b>4.1.8</b> Pressure switch failure.	<b>ACTION 1</b> - If all the above modes of failure have been checked, the pressure switch may have failed. Replace pressure switch and determine if unit will operate.

**PROBLEM 5: UNIT FAILS TO FIRE IN THE HEATING MODE, COMBUSTION AIR BLOWER ENERGIZES, IGNITOR IS ENERGIZED. (CONT.)**

Condition	Possible Cause	Corrective Action/Comments
<p align="center"><b>5.1</b></p> <ul style="list-style-type: none"> <li>- Unit operates with a cooling and continuous fan demand.</li> <li>- Combustion air blower energizes with Heating demand.</li> <li>- Ignitor is energized but unit fails to light.</li> </ul> <p>LED#1-Alternating Slow Flash LED#2-Alternating Slow Flash</p>	<b>5.1.1</b> Check that gas is being supplied to the unit.	<b>ACTION 1</b> - Check line pressure at the gas valve. Pressure should not exceed 13" WC for both natural and propane. Line pressure should read a minimum 4.5" WC for natural and 8.0"WC for propane.
	<b>5.1.2</b> Miswiring of gas valve or loose connections at multi-pin control amp plugs or valve.	<b>ACTION 1</b> - Check for correct wiring and loose connections. Correct wiring and/or replace any loose connections.
	<b>5.1.3</b> Malfunctioning gas valve or ignition control.	<b>ACTION 1</b> - Check that 24V is supplied to the gas valve approximately 35 seconds after heat demand is initiated. <b>ACTION 2</b> - Replace the valve if 24V is supplied but valve does not open (check for excessive gas line pressure before replacing gas valve). <b>ACTION 3</b> - Replace the control board if 24V is not supplied to valve.

**PROBLEM 6: BURNERS LIGHT WITH A HEATING DEMAND BUT UNIT SHUTS DOWN PREMATURELY**

Condition	Possible Cause	Corrective Action/Comments
<p align="center"><b>6.1</b></p> <ul style="list-style-type: none"> <li>- Burners fire with a heating demand.</li> <li>- Burners light but unit shuts off prior to satisfying T-stat demand.</li> <li>- Diagnostic lights flash the pressure switch code.</li> </ul> <p>LED#1-Off LED#2-Slow Flash</p>	<b>6.1.1</b> Wrong concentric vent kit used for terminating the unit.	<b>ACTION 1</b> - Check vent termination kit installed. 1-1/2" dia. concentric vent (kit60G77) for 50 and 75 inputs and 2" dia. concentric vent (kit 33K97) for 100 &125 inputs.
	<b>6.1.2</b> Condensate drain line is not draining properly.	<b>ACTION 1</b> - Check condensate line for proper vent slope, and any blockage. Condensate should flow freely during operation of furnace. Repair or replace any improperly installed condensate lines.
	<b>6.1.3</b> Low pressure differential at the pressure switch.	<b>ACTION 1</b> - Check for restricted vent inlet or exhaust. Remove all blockage. <b>ACTION 2:</b> Check for proper vent sizing. See installation instructions.
<p align="center"><b>6.2</b></p> <ul style="list-style-type: none"> <li>- Combustion air blower energizes with a heating demand.</li> <li>- Burners light but fail to stay lit.</li> <li>- After 5 tries the control diagnostics flash the watchdog burners failed to ignite code.</li> </ul> <p>LED#1-Alternating Slow Flash LED#2-Alternating Slow Flash</p>	<b>6.2.1</b> Sensor or sense wire is improperly installed.	<b>ACTION 1</b> - Check that sensor is properly located (page 10) and that the sense wire is properly attached to both the sensor and the control.
	<b>6.2.2</b> Sensor or sense wire is broken.	<b>ACTION 1</b> - Check for a broken sensor. <b>ACTION 2</b> - Test continuity across the sense wire. If wire or sensor are damaged replace the component.
	<b>6.2.3</b> Sensor or sensor wire is grounded to the unit.	<b>ACTION 1</b> - Check for resistance between the sensor rod and the unit ground. <b>ACTION 2</b> - Check for resistance between the sensor wire and the unit ground. <b>ACTION 3</b> - Correct any shorts found in circuit.
	<b>6.2.4</b> Control does not sense flame.	<b>ACTION 1</b> - Check the microamp signal from the burner flame. If the microamp signal is below 0.70 microamps, check the sense rod for proper location or contamination. <b>ACTION 2</b> - Replace, clean, or relocate flame sense rod. If rod is to be cleaned, use steel wool or replace sensor. <b>DO NOT CLEAN ROD WITH SAND PAPER. SAND PAPER WILL CONTRIBUTE TO THE CONTAMINATION PROBLEM. NOTE:</b> Do not attempt to bend sense rod.

**PROBLEM 6: BURNERS LIGHT WITH HEATING DEMAND BUT UNIT SHUTS DOWN PREMATURELY (CONT.)**

Condition	Possible Cause	Corrective Action/Comments
<p align="center"><b>6.3</b></p> <ul style="list-style-type: none"> <li>- Combustion air blower energizes with a heating demand.</li> <li>- Burners light.</li> <li>- Roll-out switch trips during the heating demand.</li> <li>- Diagnostic lights flash roll-out failure.</li> </ul> <p>LED#1-On LED#2-Slow Flash</p>	<p align="center"><b>6.3.1</b></p> <p align="center">Unit is firing above 100% of the nameplate input.</p>	<p><b>ACTION 1</b> - Check that the manifold pressure matches value listed on nameplate. See installation instructions for proper procedure.</p> <p><b>ACTION 2</b> - Verify that the installed orifice size match the size listed on the nameplate or installation instructions.</p> <p><b>ACTION 3</b> - Check gas valve sensing hose to insure no leaks are present.</p> <p><b>ACTION 4</b> - Check the input rate to verify rate matches value listed on nameplate.</p>
	<p align="center"><b>6.3.2</b></p> <p align="center">Gas orifices leak at the manifold connection.</p>	<p><b>ACTION 1</b> - Tighten orifice until leak is sealed.</p> <p><b>NOTE:</b> Be careful not to strip orifice threads. <b>ACTION 2</b> - Check for gas leakage at the threaded orifice connection. Use approved method for leak detection (see unit instructions).</p>
	<p align="center"><b>6.3.3</b></p> <p align="center">Air leakage at the connections between the primary heat exchanger, secondary heat exchanger, and combustion air blower.</p>	<p><b>ACTION 1</b> - Check for air leakage at all joints in the heat exchanger assembly. Condition will cause high CO2 with high CO.</p> <p><b>ACTION 2</b> - Seal leakage if possible (high temperature silicon is recommended), replace heat exchanger if necessary, tag and return heat exchanger to proper Lennox personnel.</p>
	<p align="center"><b>6.3.4</b></p> <p align="center">Insufficient flow through the heat exchanger caused by a sooted or restricted heat exchanger.</p>	<p><b>ACTION 1</b> - Check for sooting deposits or other restrictions in the heat exchanger assembly. Clean assembly as outlined in instruction manual.</p> <p><b>ACTION 2</b> - For G26 gas furnaces, check for proper combustion and flow. CO2 should measure between 6.0% and 8.0% for NG and between 7.5% and 9.5% for LP. CO should measure below .04% (400PPM) in an air-free sample of flue gases for either NG or LP.</p>
	<p align="center"><b>6.3.5</b></p> <p align="center">Burners are not properly located in the burner box.</p>	<p><b>ACTION 1</b> - Check that the burners are firing into the center of the heat exchanger openings. Correct the location of the burners if necessary.</p>
<p align="center"><b>6.4</b></p> <ul style="list-style-type: none"> <li>- Combustion air blower energizes with a heating demand.</li> <li>- Burners light roughly and the unit fails to stay lit.</li> <li>- Diagnostic lights flash watchguard flame failure.</li> </ul> <p>LED#1-Alternating Slow Flash LED#2-Alternating Slow Flash</p>	<p align="center"><b>6.4.1</b></p> <p align="center">Recirculation of flue gases. This condition causes rough ignitions and operation. Problem is characterized by nuisance flame failures.</p>	<p><b>ACTION 1</b> - Check for proper flow of exhaust gases away from intake vent. Remove any obstacles in front of the intake and exhaust vent which would cause recirculation.</p> <p><b>ACTION 2</b> - Check for correct intake and exhaust vent installation. See instructions</p>
	<p align="center"><b>6.4.2</b></p> <p align="center">Improper burner cross-overs</p>	<p><b>ACTION 1</b> - Remove burner and inspect the cross-overs for burrs, or any restriction or if crossover is warped. Remove restriction or replace burners.</p>

**PROBLEM 6: BURNERS LIGHT WITH HEATING DEMAND BUT UNIT SHUTS DOWN PREMATURELY (CONT.)**

<p align="center"><b>6.5</b></p> <ul style="list-style-type: none"> <li>- Combustion air blower energizes with a heating demand.</li> <li>- Burners light.</li> <li>- Diagnostic lights flash watch guard flame failure.</li> <li>- NOTE” Unit might go into 60 minute Watchguard mode depending on intermittent nature of sensor signal.</li> </ul> <p>LED#1-Alternating Slow Flash LED#2-Alternating Slow Flash</p>	<p align="center"><b>6.5.1</b></p> <p align="center">Loose sensor wire connection causes intermittent loss of flame signal.</p>	<p><b>ACTION 1</b> - Check that the sensor is properly located.</p> <p><b>ACTION 2</b> - Check that the sense wire is properly attached to both the sensor and the control. Pay extra attention to the pin connectors.</p>
---	---	--

**PROBLEM 7: CONTROL SIGNALS LOW FLAME SENSE DURING HEATING MODE**

Condition	Possible Cause	Corrective Action/Comments
<p align="center"><b>7.0</b></p> <ul style="list-style-type: none"> <li>- Unit operates correctly but the diagnostic lights flash low flame sense code.</li> </ul> <p>LED#1-Slow Flash LED#2-Fast Flash</p>	<p align="center"><b>7.1.1</b></p> <p align="center">Sense rod is improperly located on the burner.</p>	<p><b>ACTION 1</b> - Check the sense rod for proper location on the burner. Properly locate the sense rod or replace if rod cannot be located correctly.</p>
	<p align="center"><b>7.1.2</b></p> <p align="center">Sense rod is contaminated.</p>	<p><b>ACTION 1</b> - Check sense rod for contamination or coated surface. Clean the sense rod with steel wool or replace sensor. DO NOT USE SAND PAPER TO CLEAN ROD. SAND PAPER WILL CONTRIBUTE TO THE CONTAMINATION PROBLEM.</p>

**PROBLEM 8: INDOOR BLOWER FAILS TO OPERATE IN COOLING, HEATING, OR CONTINUOUS FAN MODE**

Condition	Possible Cause	Corrective Action/Comments
<p align="center"><b>8.0</b></p> <ul style="list-style-type: none"> <li>- Indoor blower fails to operate in continuous fan, cooling, or heating mode.</li> </ul>	<p align="center"><b>8.1.1</b></p> <p align="center">Miswiring of furnace or improper connections at control or indoor blower motor.</p>	<p><b>ACTION 1</b> - Correct wiring and/or replace any loose connections. Check for correct wiring and loose connections.</p>
	<p align="center"><b>8.1.2</b></p> <p align="center">120V is not being supplied to the indoor air blower or blower motor failure.</p>	<p><b>ACTION 1</b> - Check for 120V at the various calls for indoor blower by energizing "Y", "G", and "W" individually on the low voltage terminal strip. Note that when "W" is energized, the blower is delayed 45 seconds. If there is 120V to each motor tap but the blower does not operate, replace the motor.</p>
	<p align="center"><b>8.1.3</b></p> <p align="center">Defective control board</p>	<p><b>ACTION 1</b> - If there is not 120V when "Y", "G", or "W" is energized, replace the control.</p>

**PROBLEM 9: RF STATIC DURING TIME FOR IGNITION**

Condition	Possible Cause	Corrective Action/Comments
<p align="center">-AM radio interference</p>	<p align="center">Ignitor operation</p>	<p><b>ACTION 1</b>- Call Technical Support, Dallas</p>

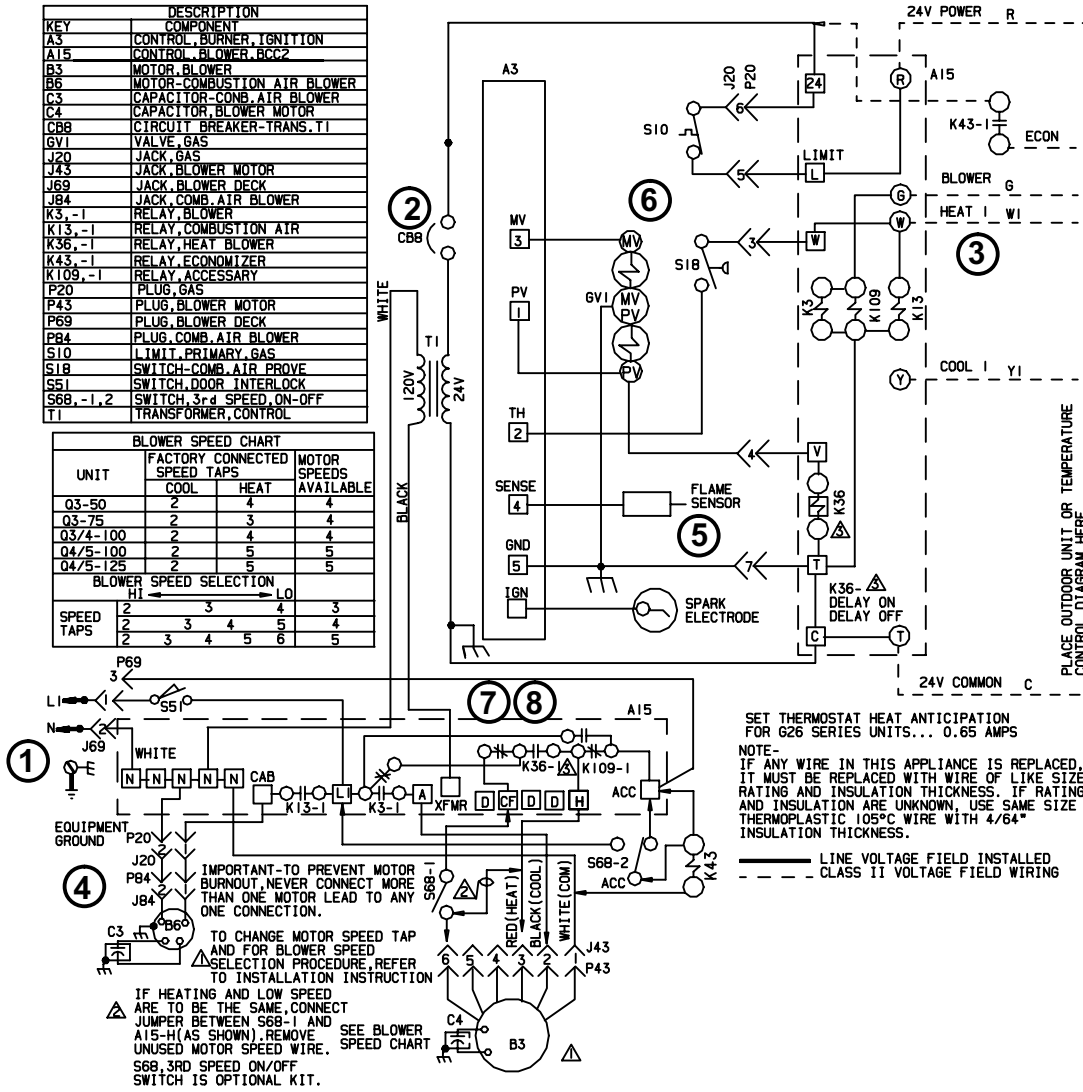


KEY	DESCRIPTION
A3	CONTROL, BURNER, IGNITION
A15	CONTROL, BLOWER, BCC2
B3	MOTOR, BLOWER
B6	MOTOR-COMBUSTION AIR BLOWER
C3	CAPACITOR-COMB AIR BLOWER
C4	CAPACITOR BLOWER MOTOR
C88	CIRCUIT BREAKER-TRANS. T1
GV1	VALVE, GAS
J20	JACK, GAS
J43	JACK, BLOWER MOTOR
J69	JACK, BLOWER DECK
J84	JACK, COMB. AIR BLOWER
K3, -1	RELAY, BLOWER
K13, -1	RELAY, COMBUSTION AIR
K36, -1	RELAY, HEAT BLOWER
K43, -1	RELAY, ECONOMIZER
K109, -1	RELAY, ACCESSARY
P20	PLUG, GAS
P43	PLUG, BLOWER MOTOR
P69	PLUG, BLOWER DECK
P84	PLUG, COMB. AIR BLOWER
S10	LIMIT, PRIMARY GAS
S18	SWITCH-COMB. AIR PROVE
S51	SWITCH DOOR INTERLOCK
S68, -1,2	SWITCH, 3rd SPEED ON-OFF
T1	TRANSFORMER, CONTROL

UNIT	FACTORY CONNECTED SPEED TAPS		MOTOR SPEEDS AVAILABLE
	COOL	HEAT	
Q3-50	2	4	4
Q3-75	2	3	4
Q3/4-100	2	4	4
Q4/5-100	2	5	5
Q4/5-125	2	5	5

BLOWER SPEED SELECTION			
H1		L0	
SPEED TAPS	2	3	4
	3	4	5
	4	5	6
	5	6	5



SET THERMOSTAT HEAT ANTICIPATION FOR G26 SERIES UNITS... 0.65 AMPS

NOTE- IF ANY WIRE IN THIS APPLIANCE IS REPLACED, IT MUST BE REPLACED WITH WIRE OF LIKE SIZE, RATING AND INSULATION THICKNESS. IF RATING AND INSULATION ARE UNKNOWN, USE SAME SIZE THERMOPLASTIC 105°C WIRE WITH 4/64" INSULATION THICKNESS.

— LINE VOLTAGE FIELD INSTALLED  
 - - - CLASS II VOLTAGE FIELD WIRING

### E- G26 -1 and -2 Models

- 1- When disconnect is closed, 120V is routed through door interlock switch (S51) to feed the line voltage side of the blower control (A3) and transformer T1 primary. Door interlock switch must be closed for A3 and T1 to receive voltage.
- 2- T1 supplies 24VAC to terminal "24VAC" on A3. In turn, terminal "R" of A3 supplies 24VAC to terminal "RC" of the indoor thermostat (not shown).
- 3- When there is a call for heat, W1 of the thermostat energizes W of the furnace control with 24VAC.
- 4- CAB of the blower control energizes the combustion air blower (B6). When the combustion air blower nears full speed, combustion air prove switch (S18) closes.

- 5- When S18 closes, assuming primary limit (S10) is closed, the ignition control opens the pilot valve and begins spark.
- 6- When flame is sensed, spark stops and main valve opens to light main burners.
- 7- After 45 seconds, blower control (A3) energizes the indoor blower.
- 8- When heat demand is satisfied, W1 of the thermostat de-energizes W of the furnace control and the furnace control immediately de-energizes the gas valve. The combustion air blower immediately stops. Also, the indoor blower runs for a designated period (90-330 seconds) as set by jumper on blower control.

F-BCC2 Blower Control -1 and -2 Models

**BCC2  
TROUBLESHOOTING  
FLOWCHART**

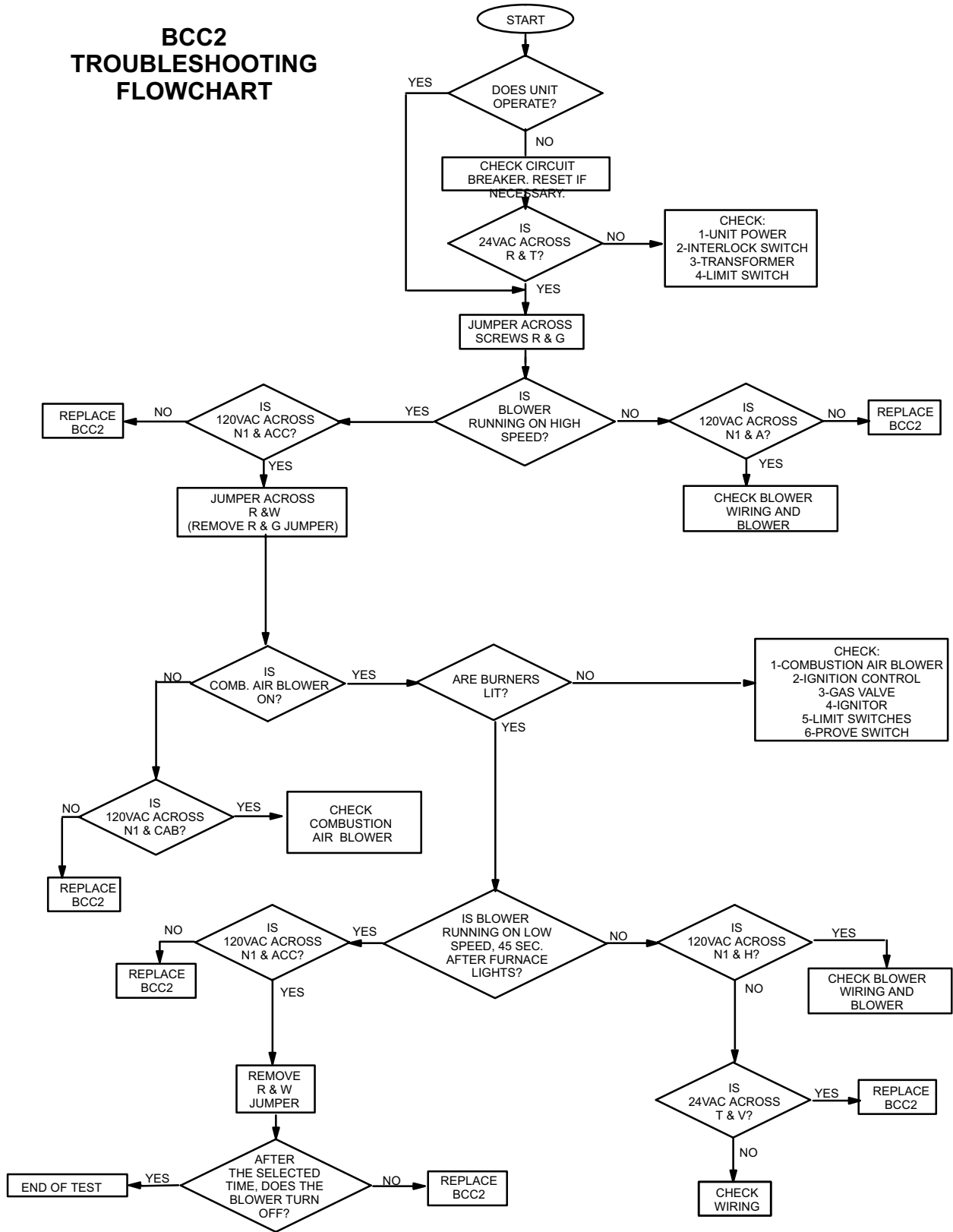


FIGURE 55

### G776 IGNITION CONTROL TROUBLESHOOTING

#### Spark is present but pilot will not light

©1993 Johnson Controls, Inc. Reprinted with permission.

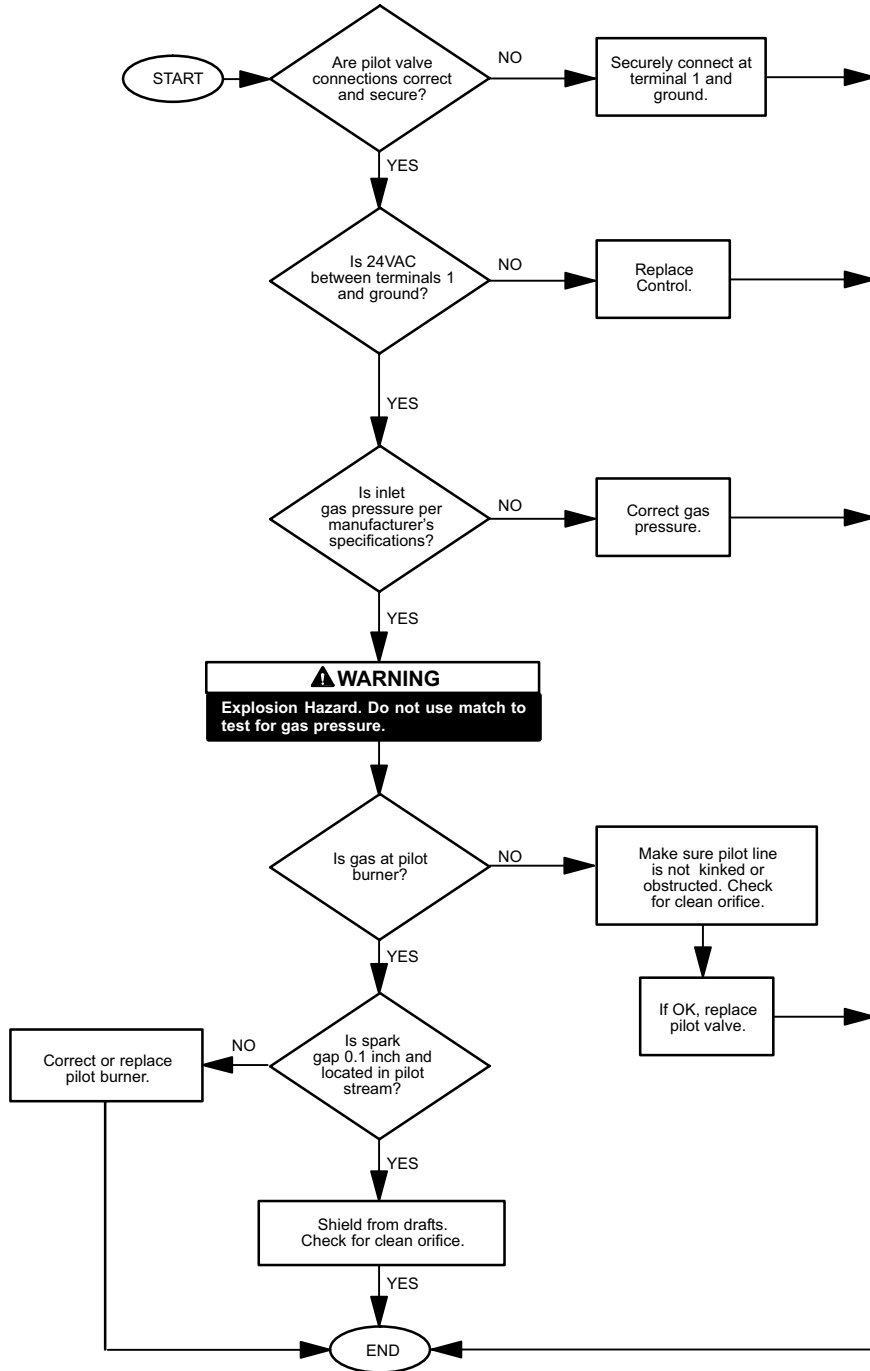
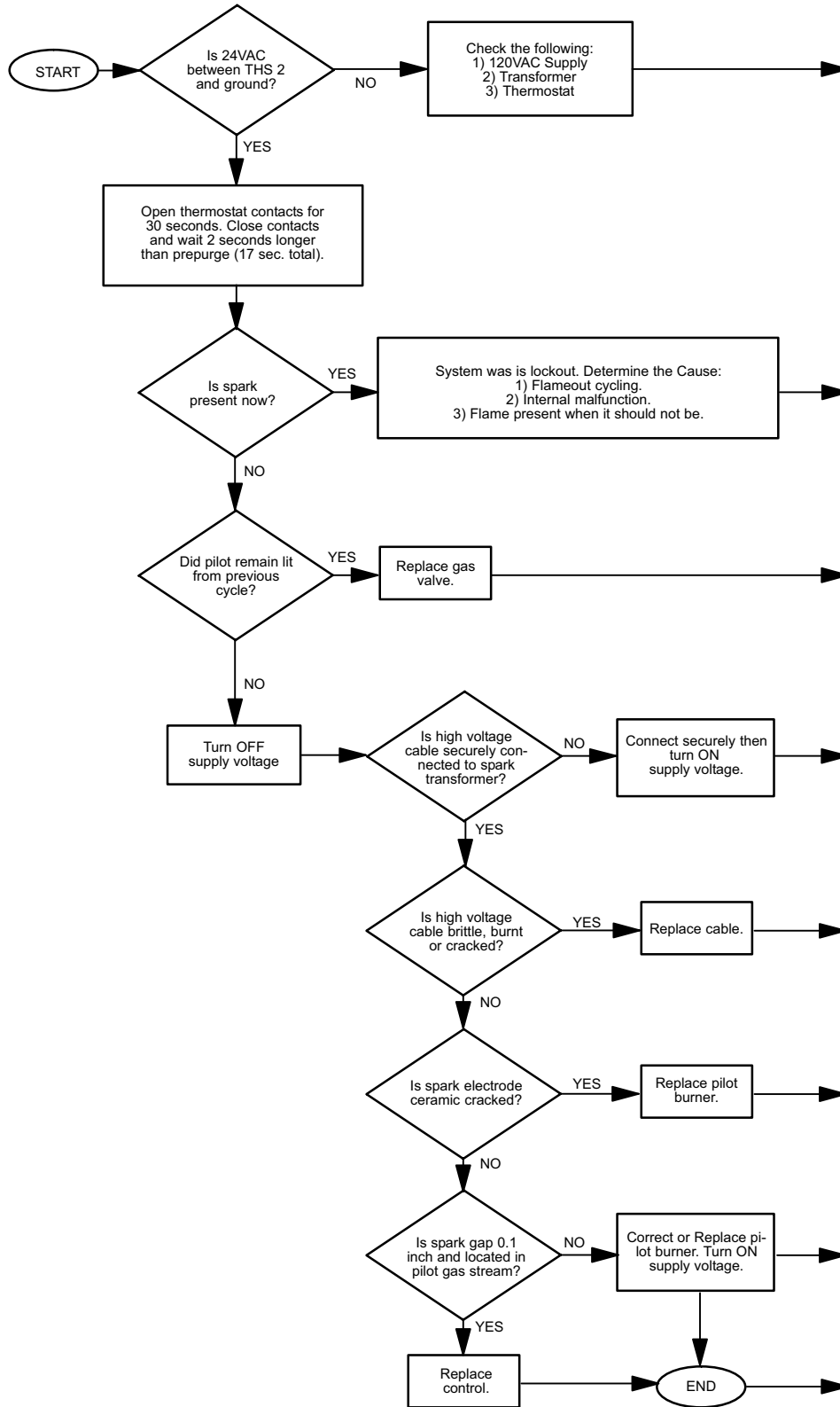


FIGURE 56

# G776 IGNITION CONTROL TROUBLESHOOTING -1 and -2 MODELS

**No spark and system will not work**

©1993 Johnson Controls, Inc. Reprinted with permission.



**FIGURE 57**

# G776 IGNITION CONTROL TROUBLESHOOTING -1 and -2 MODELS

**Pilot lights but main valve will not come on**

©1993 Johnson Controls, Inc. Reprinted with permission.

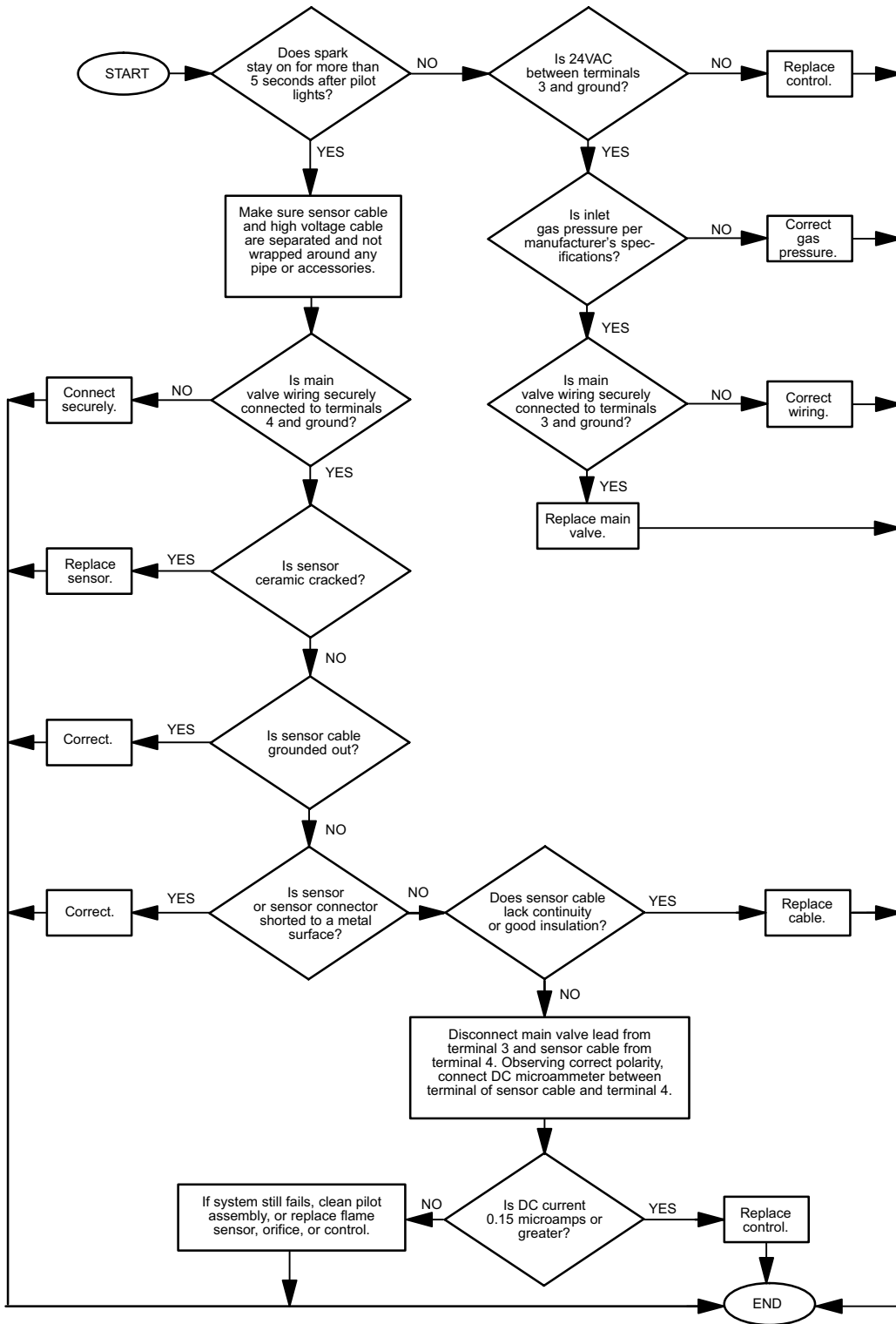


FIGURE 58