

G27M SERIES UNITS

G27M series units are mid-efficiency gas furnaces manufactured with tubular aluminized steel heat exchangers. G27M units are available in heating capacities of 60,000 to 120,000 Btuh (17.6 to 35.2 kW) and cooling applications from 1.5 through 5 tons (3.5 through 17.6 kW). Refer to Engineering Handbook for proper sizing.

Units are factory equipped for use with natural gas only. LP kits are not available. All G27M units feature the Lennox SureLight™ hot surface ignition system. The G27MX units meet the California Nitrogen Oxides (NO_x) Standards and California Seasonal Efficiency requirements. All units use a two-stage gas valve along with a two-stage induced draft blower assembly. The gas valve is redundant to assure safety shut-off as required by A.G.A. and C.G.A.

Units may be installed in upflow, downflow or horizontal position. The heat exchanger is designed for upright or horizontal use only. When the unit is installed in the downflow position, the heat exchanger must be field removed and re-installed so it is upright when the cabinet is inverted. No field conversion is required when the unit is installed in the horizontal position.

The heat exchanger, burners and manifold assembly can easily be removed for inspection and service by simply disconnecting gas, unplugging wiring harnesses and removing four screws holding the heat exchanger in place. The heat exchanger slides out of the cabinet.

Information contained in this manual is intended for use by qualified service technicians only. All specifications are subject to change. Procedures outlined in this manual are presented as a recommendation only and do not supersede or replace local or state codes.

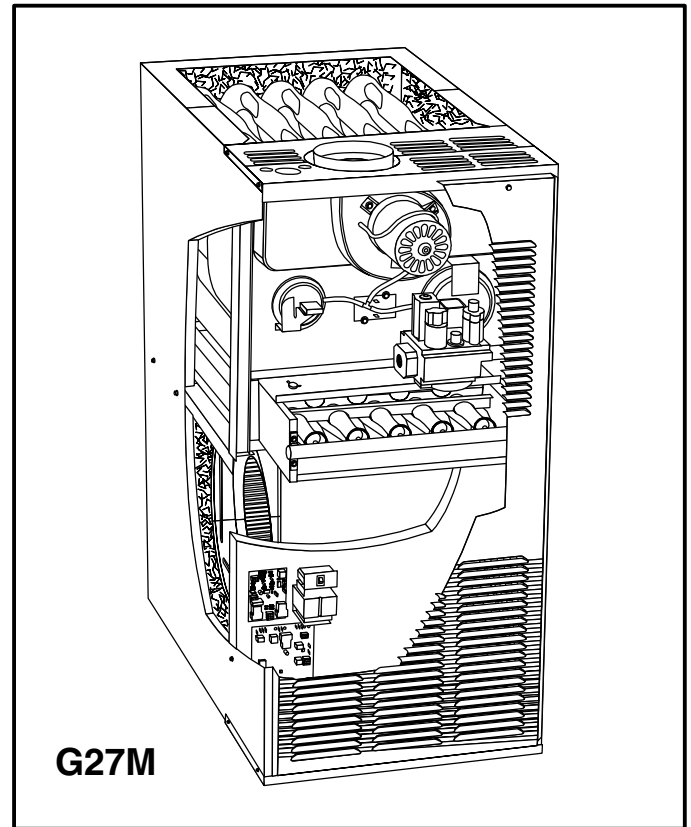

TABLE OF CONTENTS

General	1
Specifications	2
Blower Performance Data	2
I-Unit Components	4
II-Placement and Installation	11
III-Start-Up	11
IV-Heating System Service Checks	12
V-Typical Operating Characteristics	14
VI-Maintenance	15
VII-Wiring Diagram and Sequence of Operation	17
VIII-Troubleshooting	23

SPECIFICATIONS

Model No.		G27M2(X)-60	G27M3(X)-75	G27M4(X)-100	G27M5(X)-120
Input Btuh (kW) low fire		40,800 (12.0)	51,000 (14.9)	68,000 (19.9)	81,600 (23.9)
Output Btuh (kW) low fire		32,600 (9.6)	40,800 (12.0)	54,400 (16.0)	65,300 (19.1)
Input Btuh (kW) high fire		60,000 (17.6)	75,000 (22.0)	100,000 (29.3)	120,000 (35.2)
Output Btuh (kW) high fire		48,000 (14.1)	60,000 (17.6)	80,000 (23.5)	96,000 (28.2)
●A.F.U.E.		80%			
Flue size connection diameter — in. (mm) round		3 (76)	4 (102)		
Temperature rise range — °F (°C)	Low fire	30 - 60 (17 - 33)	40 - 70 (22 - 39)	30 - 60 (17 - 33)	
	High fire	40 - 70 (22 - 39)			
High static certified by A.G.A./C.G.A. — in wg. (Pa)		.50 (124)			
Gas Piping Size I.P.S. Natural gas only		1/2 (13)			
Blower wheel nominal diameter x width	in.	9 x 7	10 x 7	12 x 8	12 x 9
	mm	229 x 178	254 x 178	305 x 203	305 x 229
Blower motor output — hp (W)		1/4 (187)	1/3 (249)	1/2 (373)	3/4 (560)
Electrical characteristics		120 volts — 60 hertz — 1 phase (12 amps or less - all models)			
Nominal cooling that can be added	Tons	2 or 2.5	2, 2.5 or 3	3.5 or 4	3.5, 4 or 5
	kW	7.0 or 8.8	7.0, 8.8 or 10.6	12.3 or 14.1	12.3, 14.1 or 17.6
Up-flow/Horizontal Filter Kit (furnished) ‡filter size — in. (mm)		(1) 16 x 20 x 1 (406 x 508 x 25)		(1) 20 x 20 x 1 (508 x 508 x 25)	
Shipping weight — lbs. (kg) 1 package		135 (61)		175 (79)	
↘ Optional Accessories (Must Be Ordered Extra) ↙					
☐ Down-flow Filter Kit	Catalog No.	LB-69843A (32J01) — 3 lbs. (1 kg)			
	No. & Size of Filters — in. (mm)	(2) 16 x 20 x 1 (406 x 508 x 25)			
Down-flow Combustible Floor Base		LB-79239A (67J91) — 10 lbs. (4 kg)		LB-79239B (67J92) — 10 lbs. (4 kg)	
Hanging Bracket Kit		LB-69957 (46J66) — 15 lbs. (7 kg)			
High Altitude Pressure Switch Kits (high fire)		80K40	80K43	18L25	18L25

●Annual Fuel Utilization Efficiency based on U.S. DOE test procedures and according to FTC labeling regulations. Isolated combustion system rating for non-weatherized furnaces.

‡Polyurethane frame type filter.

☐Filters are not furnished with kit and must be ordered extra.

BLOWER PERFORMANCE DATA

G27M2(X)-60 BLOWER PERFORMANCE

External Static Pressure		Air Volume at Various Blower Speeds							
		High		Medium-High		Medium-Low		Low	
in. w.g.	Pa	cfm	L/s	cfm	L/s	cfm	L/s	cfm	L/s
0	0	1270	600	980	460	770	365	570	270
.05	12	1245	590	975	460	770	365	565	265
.10	25	1220	575	975	460	770	365	565	265
.15	37	1195	565	965	455	765	360	560	265
.20	50	1170	550	960	455	760	360	560	265
.25	62	1140	540	950	450	760	360	555	260
.30	75	1110	525	940	445	760	360	550	260
.40	100	1060	500	910	430	750	355	545	255
.50	125	990	465	880	415	740	350	540	255
.60	150	900	425	810	380	690	325	530	250
.70	175	800	380	740	350	630	295	520	245

NOTE — All air data is measured external to unit with 1 inch (25 mm) air filter in place. NOTE - Filter not furnished with unit.

BLOWER PERFORMANCE DATA

G27M3(X)-75 BLOWER PERFORMANCE

External Static Pressure		Air Volume at Various Blower Speeds							
		High		Medium-High		Medium-Low		Low	
in. w.g.	Pa	cfm	L/s	cfm	L/s	cfm	L/s	cfm	L/s
0	0	1425	670	1240	585	1000	470	800	380
.05	12	1415	670	1230	580	995	470	800	380
.10	25	1400	660	1220	575	990	465	795	375
.15	37	1385	655	1200	565	985	465	795	375
.20	50	1370	645	1180	555	980	460	790	375
.25	62	1350	635	1160	545	970	460	780	370
.30	75	1330	630	1140	540	955	450	770	365
.40	100	1280	605	1095	515	925	435	750	355
.50	125	1210	570	1040	490	900	425	720	340
.60	150	1135	535	985	465	860	405	680	320
.70	175	1070	505	920	435	800	380	630	300

NOTE — All air data is measured external to unit with 1 inch (25 mm) air filter in place. NOTE - Filter not furnished with unit.

G27M4(X)-100 BLOWER PERFORMANCE

External Static Pressure		Air Volume at Various Blower Speeds									
		High		Medium-High		Medium		Medium-Low		Low	
in. w.g.	Pa	cfm	L/s	cfm	L/s	cfm	L/s	cfm	L/s	cfm	L/s
0	0	1830	865	1600	755	1325	625	1070	505	880	415
.05	12	1815	855	1585	750	1320	625	1070	505	880	415
.10	25	1800	850	1570	740	1315	620	1070	505	880	415
.15	37	1875	885	1550	730	1310	620	1065	505	875	415
.20	50	1750	825	1530	720	1300	615	1060	500	875	415
.25	62	1725	815	1515	715	1290	610	1050	495	870	410
.30	75	1700	800	1500	710	1275	600	1040	490	870	410
.40	100	1650	780	1460	690	1245	590	1020	480	860	405
.50	125	1600	755	1420	670	1210	570	1000	470	840	395
.60	150	1550	730	1380	650	1170	550	980	460	820	385
.70	175	1480	700	1330	630	1130	535	960	455	790	375

NOTE — All air data is measured external to unit with 1 inch (25 mm) air filter in place. NOTE - Filter not furnished with unit.

G27M5(X)-120 BLOWER PERFORMANCE

External Static Pressure		Air Volume at Various Blower Speeds									
		High		Medium-High		Medium		Medium-Low		Low	
in. w.g.	Pa	cfm	L/s	cfm	L/s	cfm	L/s	cfm	L/s	cfm	L/s
0	0	2450	1155	2160	1020	1970	930	1700	800	1500	710
.05	12	2440	1150	2155	1015	1965	925	1695	800	1500	710
.10	25	2430	1145	2150	1015	1960	925	1690	800	1495	705
.15	37	2415	1140	2135	1010	1950	920	1685	795	1495	705
.20	50	2400	1135	2120	1000	1940	915	1680	795	1490	705
.25	62	2380	1125	2105	995	1930	910	1675	790	1480	700
.30	75	2360	1115	2090	985	1915	905	1670	790	1470	695
.40	100	2310	1090	2050	965	1870	880	1650	780	1440	680
.50	125	2260	1065	2000	945	1810	855	1610	760	1410	665
.60	150	2180	1030	1950	920	1750	825	1560	735	1370	645
.70	175	2100	990	1890	890	1700	800	1520	715	1330	630

NOTE — All air data is measured external to unit with 1 inch (25 mm) air filter in place. NOTE - Filter not furnished with unit.

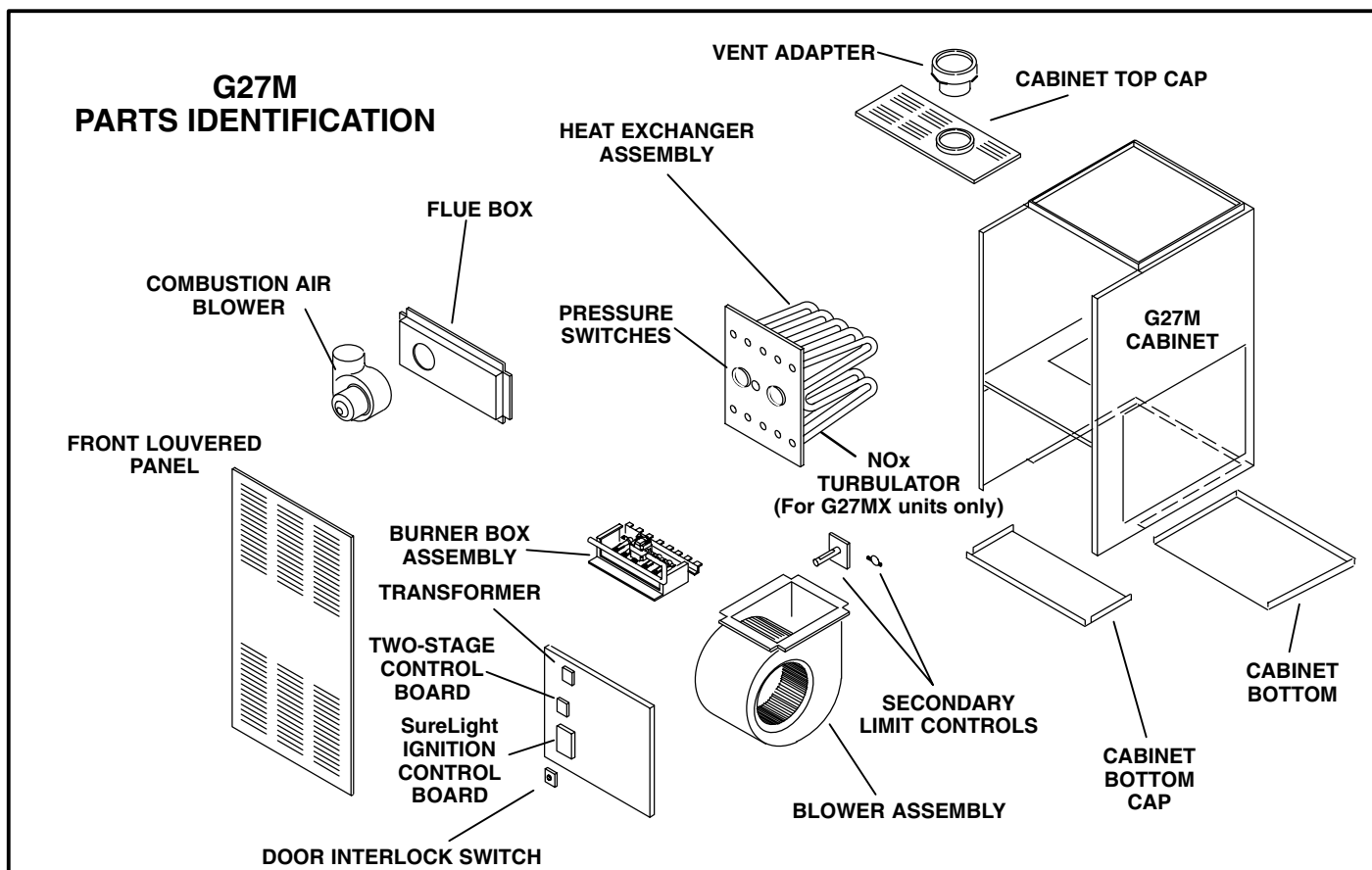

FIGURE 1

I-UNIT COMPONENTS (Figure 1)

G27M unit components are shown in figure 1. The blower controls, gas valve and burners can be accessed by removing the front access panel. A separate blower access door is located behind the front access panel. Electrical control components are mounted on the blower access door. Units are factory-equipped with bottom return air panels

A-Blower Door Components

The SureLight integrated ignition and blower control is located on the outside surface of the blower access door along with the unit transformer (T1), the two-stage control and a door interlock switch (S51). Jackplugs allow the blower door to be removed for blower service.

1- Control Transformer (T1)

A transformer located on the blower door provides power to the low voltage section of the unit. Transformers on all models are rated 40VA with a 120V primary and a 24V secondary. The transformer is protected by a 3.0 amp circuit breaker.

2-Door Interlock Switch (S51)

A door interlock switch rated 16A at 125VAC is located on the blower access door. The switch is wired in series with line voltage. When the blower door is removed the unit will shut down.

3- SureLight Ignition System (A3)

All G27M units are equipped with the Lennox Sure - Light ignition system. The system consists of an ignition control board (figure 2) and ignitor (figure 3). The board and ignitor work in combination to ensure furnace ignition and ignitor durability. The SureLight integrated board controls all major furnace operations. The board also features two LED lights for troubleshooting and two accessory terminals. See table 1 for troubleshooting diagnostic codes. Table 2 and 3 show jack plug terminal designations. Units equipped with the SureLight board can be used with either electronic or electro-mechanical thermostats without modification. The SureLight ignitor is made of durable silicon-nitrite. Ignitor longevity is also enhanced by voltage ramping by the control board. The board finds the lowest ignitor temperature which will successfully light the burner, thus increasing the life of the ignitor.

⚠ DANGER

Shock hazard.

Disconnect power before servicing. Control is not field repairable. If control is inoperable, simply replace entire control.

Can cause injury or death. Unsafe operation will result if repair is attempted.

NOTE - The G27M furnace contains electronic components that are polarity sensitive. Make sure that the furnace is wired correctly and is properly grounded.

ELECTROSTATIC DISCHARGE (ESD)

Precautions and Procedures

⚠ CAUTION

Electrostatic discharge can affect electronic components. Take precautions during furnace installation and service to protect the furnace's electronic controls. Precautions will help to avoid control exposure to electrostatic discharge by putting the furnace, the control and the technician at the same electrostatic potential. Neutralize electrostatic charge by touching hand and all tools on an unpainted unit surface, such as the gas valve or blower deck, before performing any service procedure.

a-Electronic Ignition

On a call for heat the SureLight control monitors the combustion air blower pressure switch. The control will not begin the heating cycle if the pressure switch is closed (bypassed). Once the pressure switch is determined to be open, the combustion air blower is energized. When the differential in the pressure switch is great enough, the pres-

sure switch closes and a 15-second pre-purge begins. If the pressure switch is not proven within 2-1/2 minutes, the control goes into Watchguard-Pressure Switch mode for a 5-minute re-set period.

After the 15-second pre-purge period, the SureLight ignitor warms up for 20 seconds after which the gas valve opens for a 4-second trial for ignition. G27M units with board 63K89, 24L85 or 56L83: the ignitor stays energized for the first second of the 4-second trial. G27M units with board 97L48: ignitor stays energized for the full 4-second trial for ignition. If ignition is not proved during the 4-second period, the control will try four more times. After a total of five trials for ignition (including the initial trial), the control goes into Watchguard-Flame Failure mode. After a 60-minute reset period, the control will begin the ignition sequence again.

The SureLight control board has an added feature that prolongs the life of the ignitor. After a successful ignition, the SureLight control utilizes less power to energize the ignitor on successive calls for heat. The control continues to ramp down the voltage to the ignitor until it finds the lowest amount of power that will provide a successful ignition. This amount of power is used for 255 cycles. On the 256th call for heat, the control will again ramp down until the lowest power is determined and the cycle begins again.

TABLE 1

DIAGNOSTIC CODES		
MAKE SURE TO ID LED'S CORRECTLY: REFER TO INSTALLATION INSTRUCTIONS FOR CONTROL BOARD LAYOUT.		
LED #1	LED #2	DESCRIPTION
SIMULTANEOUS SLOW FLASH	SIMULTANEOUS SLOW FLASH	Power - Normal operation Also signaled during cooling and continues fan.
SIMULTANEOUS FAST FLASH	SIMULTANEOUS FAST FLASH	Normal operation - signaled when heating demand initiated at thermostat.
SLOW FLASH	ON	Primary or Secondary limit open. Units with board 63K8901 or 24L85: Limit must close within 5 trials for ignition or board goes into one hour limit Watchguard. Units with board 56L83 or 97L48: Limit must close within 3 minutes or board goes into one hour limit Watchguard.
OFF	SLOW FLASH	Pressure switch open or has opened 5 times during a single call for heat; OR: Blocked inlet/exhaust vent; OR: Condensate line blocked; OR: Pressure switch closed prior to activation of combustion air blower.
ALTERNATING SLOW FLASH	ALTERNATING SLOW FLASH	Watchguard - burners fail to ignite.
SLOW FLASH	OFF	Flame sensed without gas valve energized.
ON	SLOW FLASH	Rollout switch open. OR: 9 pin connector improperly attached.
ON ON OFF	ON OFF ON	Circuit board failure or control wired incorrectly.
FAST FLASH	SLOW FLASH	Main power polarity reversed. Switch line and neutral.
SLOW FLASH	FAST FLASH	Low flame signal. Measures below .61 microAmps. Replace flame sense rod.
ALTERNATING FAST FLASH	ALTERNATING FAST FLASH	Improper main ground or line voltage below 75 volts; OR: Broken ignitor; OR: Open ignitor circuit.

NOTE - Slow flash equals 1 Hz (one flash per second). Fast flash equals 3 Hz (three flashes per second). Drop out flame sense current < 0.21 microAmps

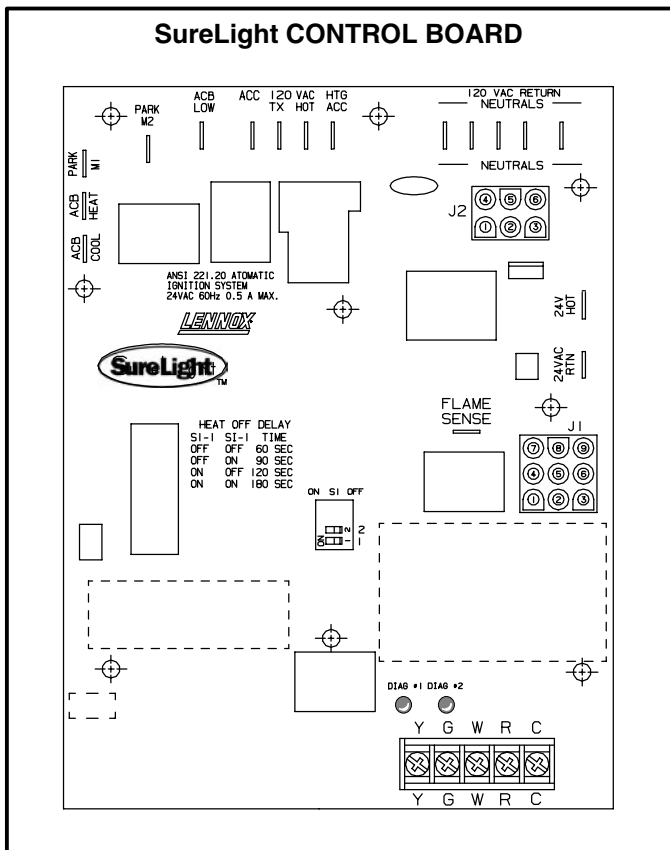

FIGURE 2

TABLE 3

SureLight BOARD J58 (J1) TERMINAL DESIGNATIONS	
PIN #	FUNCTION
1	Primary Limit In
2	Not Used
3	Roll Out Switch Out
4	Gas Valve 24V
5	Pressure Switch In
6	Primary Limit Out
7	Not Used
8	Roll Out Switch In
9	Ground

b-Fan Time Control

The fan on time of 45 seconds is not adjustable. Fan off time (time that the blower operates after the heat demand has been satisfied) can be adjusted by flipping the dip switches located on the SureLight integrated control. The unit is shipped with a factory fan off setting of 90 seconds. Fan off time will affect comfort and is adjustable to satisfy individual applications. See figure 4.

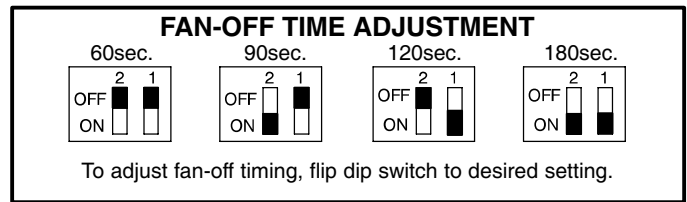

FIGURE 4

4- Two-Stage Control (A86)

All G27M units are equipped with a two-stage control board. Two different boards have been used. See figure 5. Board 43K9001 and board 25M3301 are identical, except the 9 pin connector on board 43K9001 is replaced by two relays with quick connect terminals on 25M3301. Both boards have identical operating characteristics, the difference being cosmetic only. The two-stage board acts as a go between from the indoor thermostat to the SureLight ignition board. The board can be utilized in three modes: with a SINGLE-STAGE thermostat, a TWO-STAGE thermostat or with a second-stage (high fire) delay called W2 TIMED. The two-stage board is equipped with a jumper (see figure 5) which changes operating modes and a jumper which adjusts second-stage heat delay during W2 TIMED mode. While in the single-stage thermostat mode, the unit will always operate on second-stage heat. The combustion air blower (B6) will operate on high speed and indoor blower (B3) will operate on heating speed. While in the two-stage thermostat mode the unit will operate on first-stage heat (low fire). The combustion air blower (B6) and indoor blower (B3) will operate on low speed. The unit will switch to second-stage heat (high fire) on call from the indoor thermostat W2. While in the W2 TIMED mode the unit will fire on first-stage heat (low fire) with the combustion air blower (B6) and indoor blower (B3) operating on low speed. After a set time delay the unit switches to second-stage heat (high fire). The combustion air blower and indoor blower also switch to second-stage heat mode.

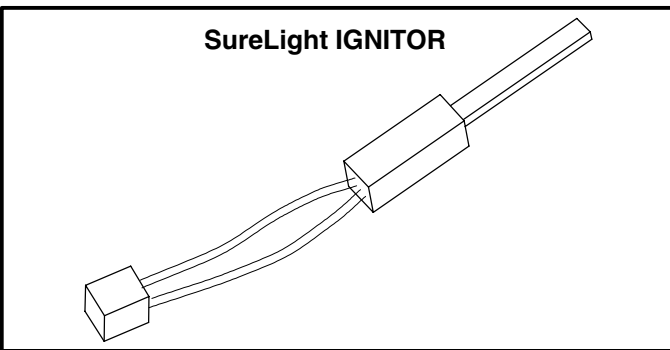
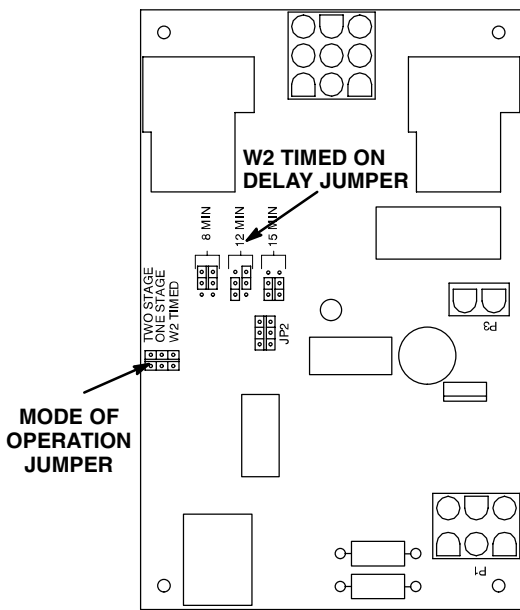

FIGURE 3

TABLE 2

SureLight BOARD J156 (J2) TERMINAL DESIGNATIONS	
PIN #	FUNCTION
1	Ignitor
2	Not Used
3	Ignitor Neutral
4	Combustion Air Blower Line Voltage
5	Not Used
6	Combustion Air Blower Neutral

TWO-STAGE CONTROL BOARD 43K9001



TWO-STAGE CONTROL BOARD 25M3301

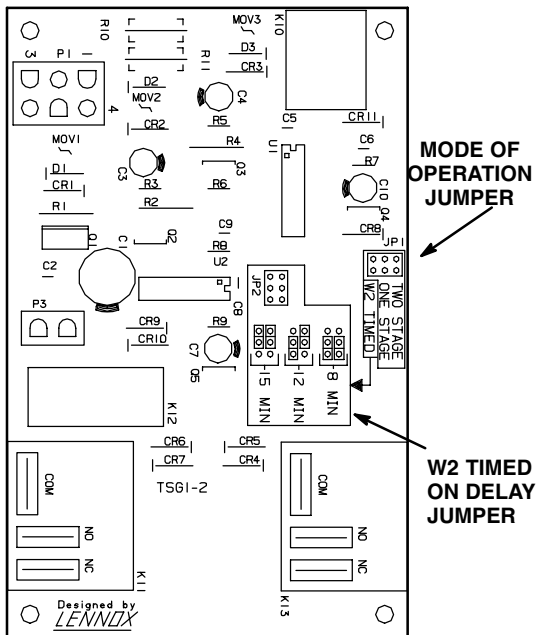

FIGURE 5

B-Blower Motor Assembly

All G27M units use direct drive blower motors. All motors used are 120V permanent split capacitor motors to ensure maximum efficiency. See table 4 for ratings.

Table 4

G27M BLOWER RATINGS 120V		
BLOWER MOTOR	HP	CAP
G27M2-60	1/4	5MF 370V
G27M3-75	1/3	5MF 370V
G27M4-100	1/2	7.5MF 370V
G27M5-120	3/4	40MF 370V

Secondary Limit Switches [(1)S21 and (2)S21]

The secondary limit switches [(1)S21 and (2)S21] on G27M units are located in the blower compartment on the back side of the blower housing (see figure 6). When excess heat is sensed in the blower compartment, the limit will open. If the limit is tripped, the SureLight control energizes the supply air blower and closes the gas valve. The limit automatically resets when unit temperature returns to normal. Two limits are supplied in each furnace. Figure 7 shows both switches. Both switches are N.C. SPST auto-reset switches which actuate on a temperature rise. The switches are factory set and cannot be adjusted. The (1)S21 limit shown on the top opens at $140^{\circ}\text{F} \pm 5^{\circ}\text{F}$ ($60.0^{\circ}\text{C} \pm 2.8^{\circ}\text{C}$) on a temperature rise and closes at $110^{\circ}\text{F} \pm 10^{\circ}\text{F}$ ($43.3^{\circ}\text{C} \pm 5.6^{\circ}\text{C}$). The (2)S21 limit shown on the bottom opens at $165^{\circ}\text{F} \pm 5^{\circ}\text{F}$ ($73.9^{\circ}\text{C} \pm 2.8^{\circ}\text{C}$) on a temperature rise and closes at $135^{\circ}\text{F} \pm 8^{\circ}\text{F}$ ($57.2^{\circ}\text{C} \pm 4.4^{\circ}\text{C}$).

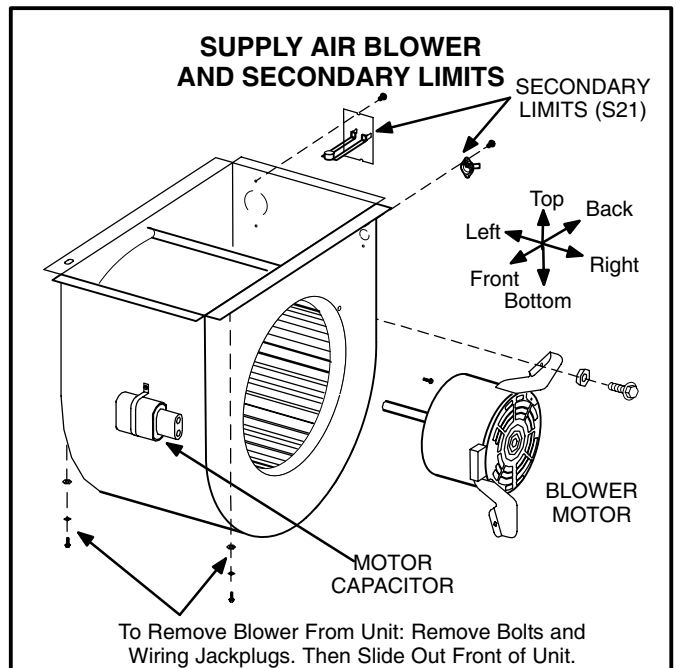

FIGURE 6

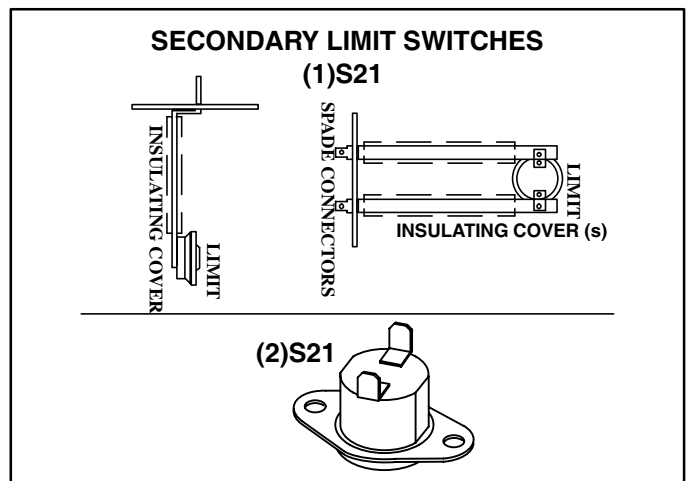

FIGURE 7

HEATING COMPONENTS (shown in horizontal position)

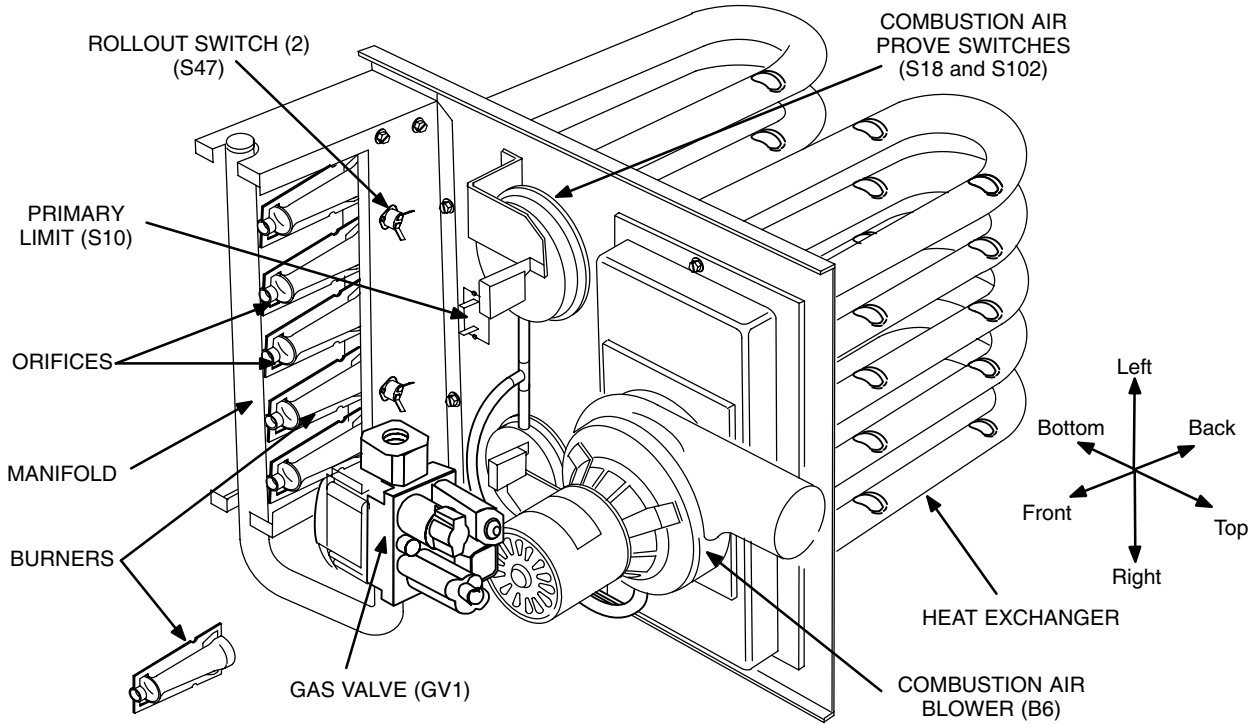

FIGURE 8

G27M BURNER ASSEMBLY (shown in upflow position)

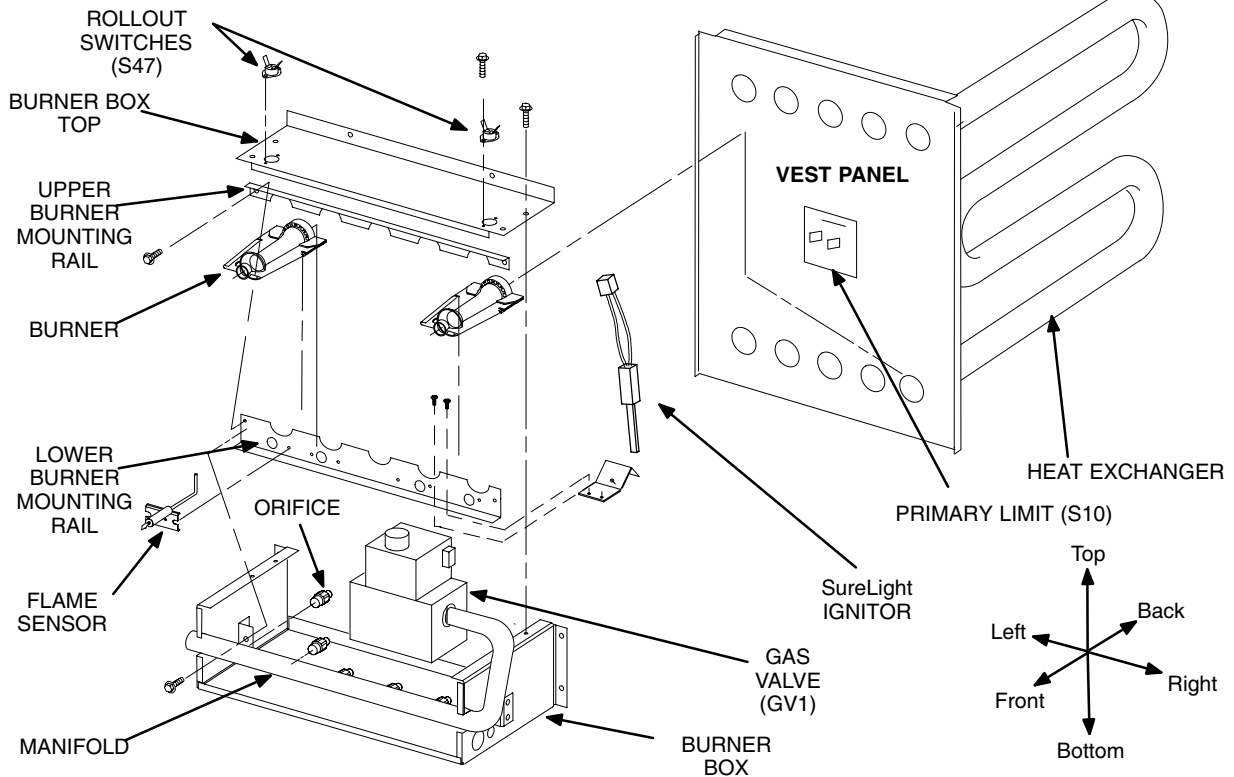

FIGURE 9

C-Heating Components (Figures 8 and 9)

Heating components are located inside the front louvered panel. Inside the heating compartment are the combustion air blower (B6), flame rollout switches (S47), primary limit control (S10), ignitor, flame sensor, gas valve (GV1), and the combustion air blower prove switches (S18 and S102).

1-Combustion Air Blower (B6)

All G27M units use a two-stage combustion air blower to move air through the burners and heat exchanger during heating operation. The blower uses a 120VAC motor. The motor operates during all heating operation and is controlled by the SureLight integrated control A3. The blower operates for 15 seconds before burner ignition (pre-purge) and for 5 seconds after the gas valve closes (post-purge). The combustion air blower operates on low speed during first-stage heat (low fire), then switches to high speed for second-stage heat (high fire).

2-Flame Rollout Switches (S47)

Flame rollout switch is a high temperature limit switch located on top of the burner box (see figure 11). Each furnace is equipped with two identical switches. One switch is located over the leftmost burner and the other switch is located over the rightmost burner. The switch is a N.C. SPST manual-reset switch which opens at $260^{\circ}\text{F} \pm 12^{\circ}\text{F}$ ($126.7^{\circ}\text{C} \pm 6.7^{\circ}\text{C}$) on a temperature rise. The switch is factory set and cannot be adjusted. To manually reset a tripped switch, push the reset button located on the control. The switches are connected in series and monitored by the SureLight control A3. When S47 senses

rollout, the control immediately stops ignition and closes the gas valve. If unit is running and flame rollout is detected, the gas valve will close and ignition control will be disabled. Rollout can be caused by a restricted heat exchanger or a blocked flue.

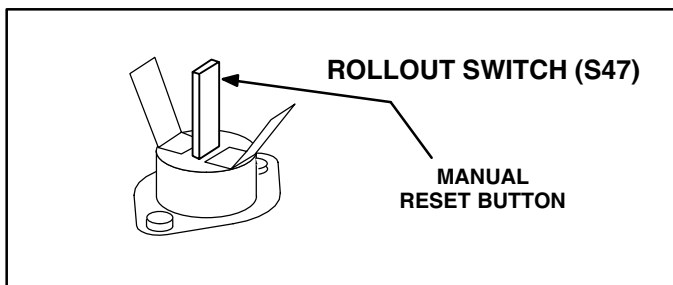

FIGURE 10

3-Primary Limit Control (S10)

The primary limit (S10) is located in the middle of the heating vestibule panel (see figure 9). S10 is the same type of limit as (1) S21 or (2) S21 as shown in figure 7. G27M-60 and -75 units use the same type limit as (1) S21. G27M-100 and -120 units use the same type limit as (2) S21. When excess heat is sensed in the heat exchanger, the limit will open. If the limit is tripped, the SureLight control energizes the supply air blower and closes the gas valve. The limit automatically resets when unit temperature returns to normal. The switch is factory set and cannot be adjusted. The switch has different setpoints for each unit model number. However, the set point will be printed on the side of the limit.

4-Gas Valve (GV1)

The G27M uses a gas valve manufactured by White Rodgers. The valve is a two-stage internally redundant to assure safety shut-off. If the gas valve must be replaced, the same type valve must be used.

24VAC terminals and gas control knob are located on top of the valve. All terminals on the gas valve are connected to wires from the SureLight integrated control. 24V applied to the terminals energizes the valve.

Inlet and outlet pressure taps are located on the valve. A regulator adjustment screw is located on the side of the valve. Refer to figure 11 for location of valve features.

NOTE-Do not attempt to regulate low fire manifold pressure.

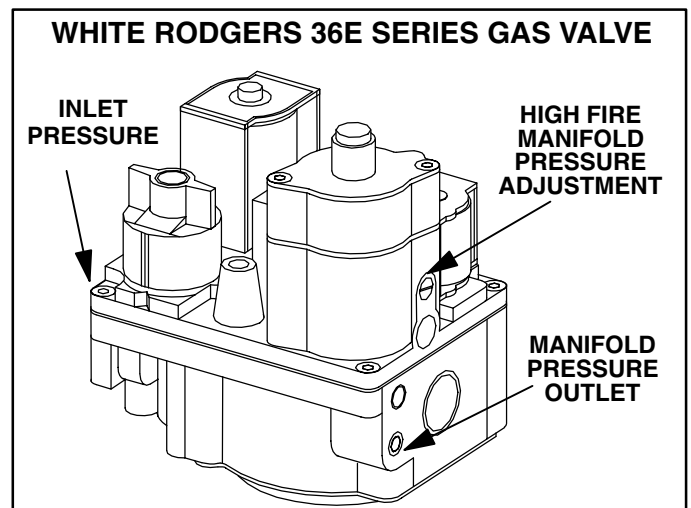

FIGURE 11

5-SureLight Ignitor

Figure 12 and 14 shows the position of the SureLight hot surface ignitor in perspective with the rest of the burner assembly. The hot surface ignitor lights the two rightmost burners and the burners cross-light to the left. A flame retention ring in the end of each burner is used to maintain correct flame length and shape and to keep the flame from lifting off the burner head. The hot surface ignitor is rated at 1800°F (982°C) in 17 seconds with a 120VAC 4 amp power source.

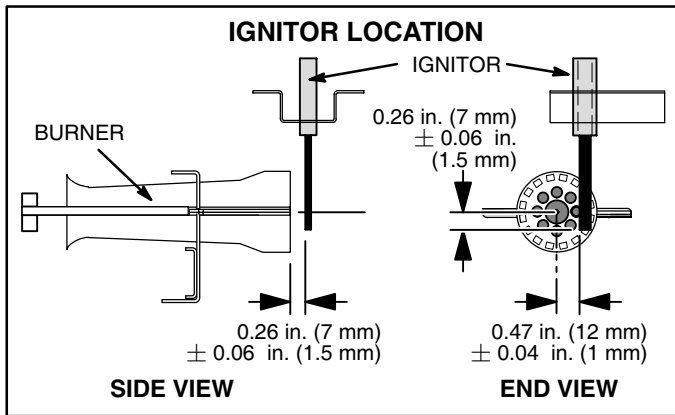

FIGURE 12

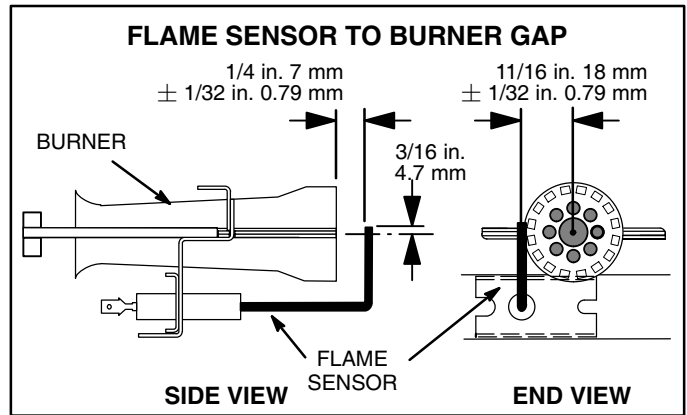

FIGURE 13

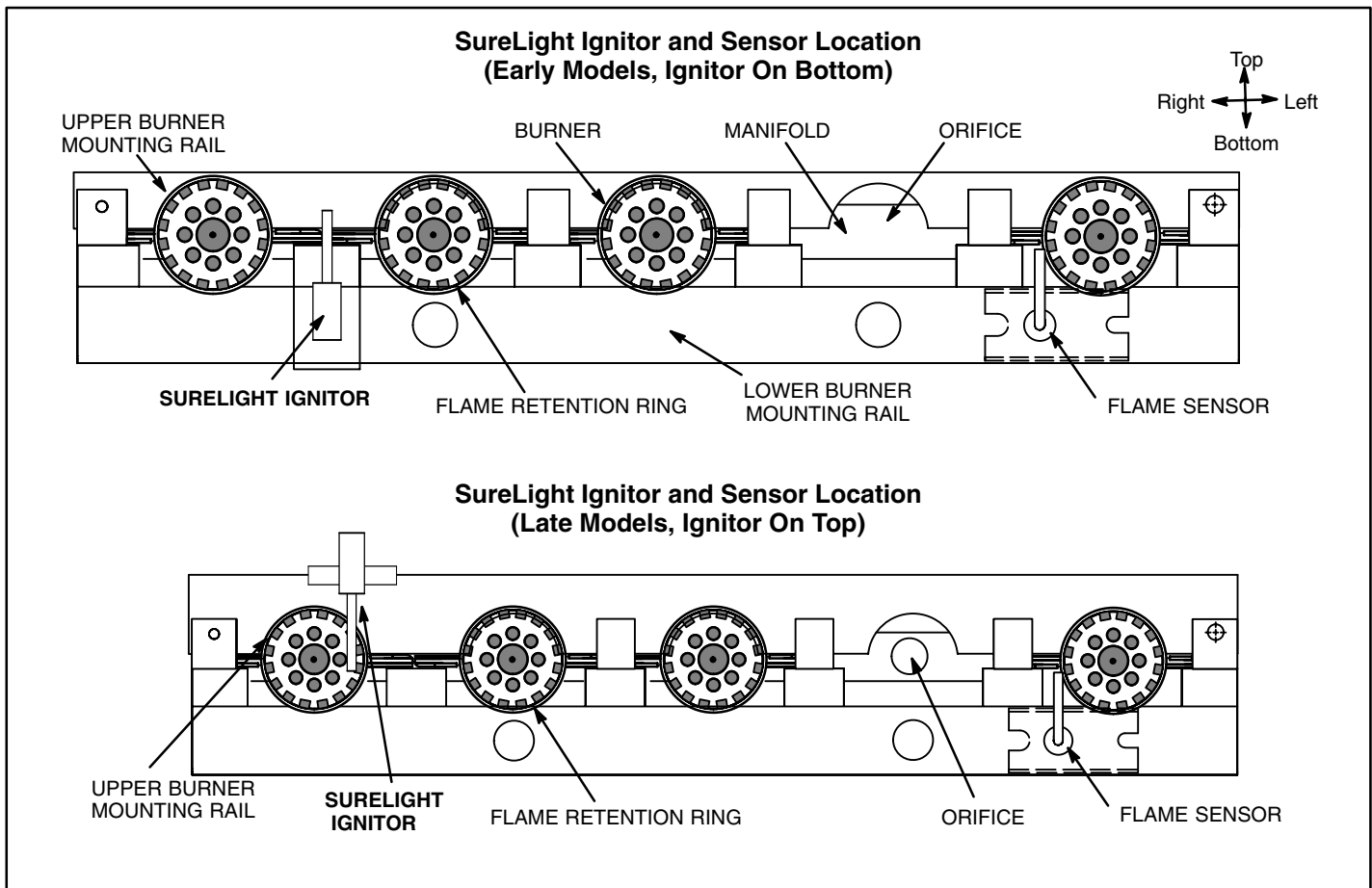

FIGURE 14

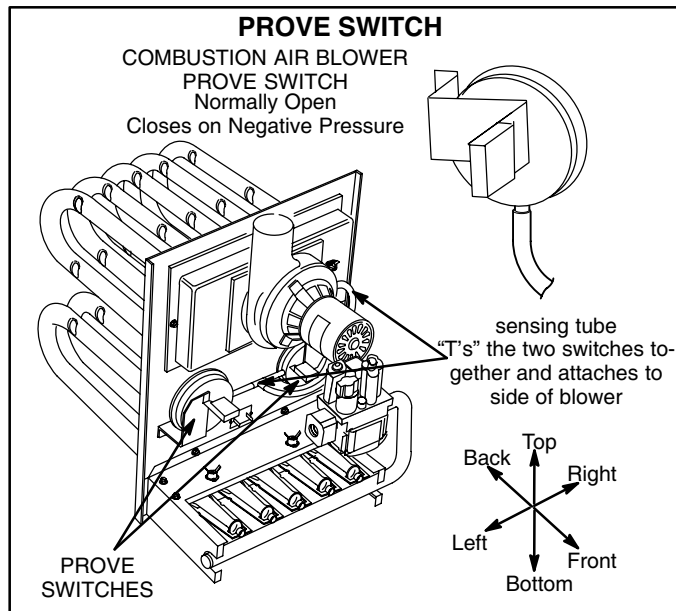

FIGURE 15

7-Combustion Air Blower Prove (Pressure) Switches (S128 and S102)

G27M series units are equipped with two combustion air prove switches. S128 (low fire) and S102 (high fire) are located on the vestibule panel. The switches “T” together and are connected to the combustion air blower housing by a flexible silicone hose. The switches monitor air pressure in the combustion air blower housing.

Both switches are N.O. SPST auto-reset pressure switches electrically connected to the integrated control A3. The switches prevent burner operation if the combustion air blower is not operating properly and in case of flue blockage.

On start-up, the S128 and S102 switches sense whether the combustion air blower is operating. The switches close a circuit to the burner control when pressure inside the combustion air blower decreases below a given setpoint (see table 5). The pressure sensed by the switches is relative to atmospheric pressure. If the flue becomes obstructed during operation, and either switch senses a loss of negative pressure (pressure approaches atmospheric pressure) the switch opens the circuit to the burner control and gas valve. Either switch, if opened, will open the circuit. The switch trip pressures are different depending on unit size. The trip pressures are printed on the side of the switches.

All the switches provide factory set and are not field adjustable. The switches provide a safety shut-down control in the furnace and must not be bypassed for any reason.

TABLE 5

MODEL NUMBER	S102 HIGH	S128 LOW
G27M3-60	.52"W.C. ± 0.05"W.C. (129.37 Pa ± 12.43Pa)	0.29"W.C. ± 0.05"W.C. (72.10Pa ± 12.43Pa)
G27M-75	0.56"W.C. ± 0.05"W.C. (139.23Pa ± 12.43Pa)	0.29"W.C. ± 0.05"W.C. (72.05Pa ± 12.43Pa)
G27M-100	0.65"W.C. ± 0.03"W.C. (161.61Pa ± 7.5Pa)	0.43"W.C. ± 0.05"W.C. (107Pa ± 12.43Pa)
G27M-120	0.68"W.C. ± 0.03"W.C. (169Pa ± 7.53Pa)	0.53"W.C. ± 0.05"W.C. (131.77Pa ± 12.43Pa)

NOTE: All measurements are negative.

II-PLACEMENT AND INSTALLATION

Make sure unit is installed in accordance with the G27M installation instructions.

III-START-UP

A-Preliminary and Seasonal Checks

- 1 - Inspect electrical wiring, both field and factory installed for loose connections. Tighten as required.
- 2 - Check voltage at disconnect switch. Voltage must be within range listed on the nameplate. If not, consult the power company and have voltage condition corrected before starting unit.

B-Heating Start-Up

- 1 - Set thermostat to OFF position. Close manual knob on gas valve.
- 2 - Wait 5 minutes.
- 3 - Open manual knob on gas valve, replace the front access panel and turn on unit electrical supply.

⚠ WARNING

Shock and burn hazard.

G27M units are equipped with a hot surface ignition system. Do not attempt to light manually.

- 4 - Set fan switch to AUTO or ON and move system selection switch to HEAT. Adjust thermostat to a setting above room temperature.
- 5 - If unit does not light the first time, it will attempt four more ignitions before locking out.
- 6 - If lockout occurs, repeat steps 1, 2, 3 and 4.
- 7 - On start-up check operation of both high and low fire. Refer to section IV item E for manifold pressure check procedure.

C-Safety or Emergency Shutdown

Turn off unit power. Close manual and main gas valves.

D-Extended Period Shutdown

Turn off thermostat or set to “UNOCCUPIED” mode. Close all gas valves (both internal and external to unit) to guarantee no gas leak into combustion chamber. Turn off power to unit. All access panels, covers and vent caps must be in place and secured.

IV-HEATING SYSTEM SERVICE CHECKS

A-A.G.A. / C.G.A. Certification

All G27M units are A.G.A. / C.G.A. design certified without modifications. Refer to the G27M Installation Instruction for Information.

B-Gas Piping

Gas supply piping should not allow more than 0.5"W.C. drop in pressure from unit with gas valve off and with unit operating at second-stage heat (high fire). Supply gas pipe must not be smaller than unit gas connection. Refer to table 6 if pressure drop exceeds 0.5"W.C. or if gas piping is suspect. Do not operate furnace below nameplate minimum line pressure.

C-Testing Gas Piping

⚠ IMPORTANT

In case emergency shutdown is required, turn off the main shut-off valve and disconnect the main power to unit. These controls should be properly labeled by the installer.

When pressure testing gas lines, the gas valve must be disconnected and isolated. Gas valves can be damaged if subjected to more than 0.5psig (14" W.C.). See figure 16. If the pressure is equal to or less than 0.5psig (14"W.C.), use the manual shut-off valve before pressure testing to isolate furnace from gas supply.

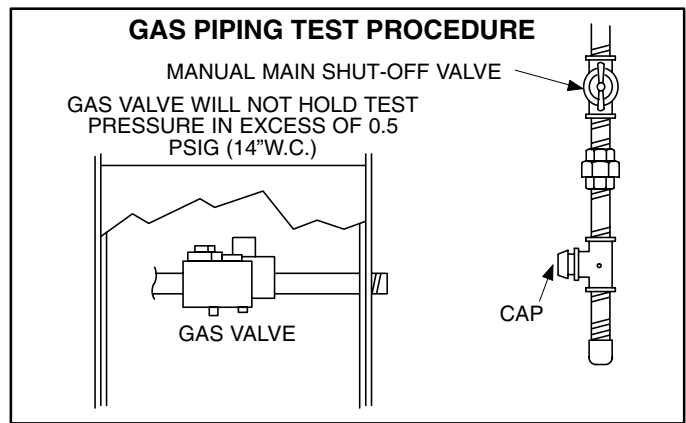

FIGURE 16

When checking piping connections for gas leaks, use preferred means. Kitchen detergents can cause harmful corrosion on various metals used in gas piping. Use of a specialty gas leak detector is strongly recommended. It is available through Lennox under part number 31B2001. See Corp. 8411-L10, for further details.

Do not use matches, candles, flame or any other source of ignition to check for gas leaks.

D-Testing Gas Supply Pressure

When testing supply gas pressure, connect test gauge to inlet pressure tap on the gas valve. Check gas line pressure with unit firing at maximum rate. Low pressure may result in erratic operation or underfire. High pressure can result in permanent damage to gas valve or overfire. For natural gas units, operating pressure at unit gas connection must be a minimum of 5.0" W.C. but no more than 13.0"W.C. at any time.

TABLE 6
GAS PIPE CAPACITY - FT³/HR (kL/HR)

Nominal Iron Pipe Size -Inches(mm)	Internal Diameter -Inches(mm)	Length of Pipe-Feet(m)									
		10 (3.048)	20 (6.096)	30 (9.144)	40 (12.192)	50 (15.240)	60 (18.288)	70 (21.336)	80 (24.384)	90 (27.432)	100 (30.480)
1/4 (6.35)	.364 (9.246)	43 (1.13)	29 (.82)	24 (.68)	20 (.57)	18 (.51)	16 (.45)	15 (.42)	14 (.40)	13 (.37)	12 (.34)
3/8 (9.53)	.493 (12.522)	95 (2.69)	65 (1.84)	52 (1.47)	45 (1.27)	40 (1.13)	36 (1.02)	33 (.73)	31 (.88)	29 (.82)	27 (.76)
1/2 (12.7)	.622 (17.799)	175 (4.96)	120 (3.40)	97 (2.75)	82 (2.32)	73 (2.07)	66 (1.87)	61 (1.73)	57 (1.61)	53 (1.50)	50 (1.42)
3/4 (19.05)	.824 (20.930)	360 (10.19)	250 (7.08)	200 (5.66)	170 (4.81)	151 (4.28)	138 (3.91)	125 (3.54)	118 (3.34)	110 (3.11)	103 (2.92)
1 (25.4)	1.049 (26.645)	680 (919.25)	465 (13.17)	375 (10.62)	320 (9.06)	285 (8.07)	260 (7.36)	240 (6.80)	220 (6.23)	205 (5.80)	195 (5.52)
1-1/4 (31.75)	1.380 (35.052)	1400 (39.64)	950 (26.90)	770 (21.80)	660 (18.69)	580 (16.42)	530 (15.01)	490 (13.87)	460 (13.03)	430 (12.18)	400 (11.33)
1-1/2 (38.1)	1.610 (40.894)	2100 (59.46)	460 (41.34)	1180 (33.41)	990 (28.03)	900 (25.48)	810 (22.94)	750 (21.24)	690 (19.54)	650 (18.41)	620 (17.56)
2 (50.8)	2.067 (52.502)	3950 (111.85)	2750 (77.87)	2200 (62.30)	1900 (53.80)	1680 (47.57)	1520 (43.04)	1400 (39.64)	1300 (36.81)	1220 (34.55)	1150 (32.56)
2-1/2 (63.5)	2.469 (67.713)	6300 (178.39)	4350 (123.17)	3520 (99.67)	3000 (84.95)	2650 (75.04)	2400 (67.96)	2250 (63.71)	2050 (58.05)	1950 (55.22)	1850 (52.38)
3 (76.2)	3.068 (77.927)	11000 (311.48)	7700 (218.03)	6250 (176.98)	5300 (150.07)	4750 (134.50)	4300 (121.76)	3900 (110.43)	3700 (104.77)	3450 (97.69)	3250 (92.03)
4 (101.6)	4.026 (102.260)	23000 (651.27)	15800 (447.39)	12800 (362.44)	10900 (308.64)	9700 (274.67)	8800 (249.18)	8100 (229.36)	7500 (212.37)	7200 (203.88)	6700 (189.72)

NOTE-Capacity given in cubic feet of gas per hour (kilo liters of gas per hour) and based on 0.60 specific gravity gas.

On multiple unit installations, each unit should be checked separately, with and without other units operating. Supply pressure must be a minimum of 5.0" W.C. for each unit but no more than 13.0"W.C. at any time.

E-Check Manifold Pressure

After line pressure has been checked and adjusted, check manifold pressure. Move pressure gauge to outlet pressure

tap located on unit gas valve (GV1). Checks of manifold pressure are made as verification of proper regulator adjustment. Manifold pressure for the G27M can be measured at any time the gas valve is open and is supplying gas to the unit. Normal manifold pressure for natural gas units is 3.5" W.C. (870.2 Pa) for high fire operation and 1.7" W.C. (422.7 Pa) for low fire.

⚠ IMPORTANT

For safety, connect a shut-off valve between the manometer and the gas tap to permit shut off of gas pressure to the manometer.

The gas valve is factory set and should not require adjustment. All gas valves are factory regulated.

Manifold Pressure Check Procedure:

- 1 - Connect manometer to outlet pressure tap on gas valve (see figure 17 for outlet tap location). Start unit and allow 5 minutes for unit to reach steady state.
- 2 - While waiting for the unit to stabilize, notice the flame. Flame should be stable and should not lift from burner. Natural gas should burn blue.
- 3 - After allowing unit to stabilize for 5 minutes, record manifold pressure and compare to the normal manifold pressure of 3.5" W.C. (870.2 Pa) for high fire operation or 1.7" W.C. (422.7 Pa) for low fire.

NOTE-Shut unit off, turn gas valve to "OFF" position and remove manometer as soon as an accurate reading has been obtained. Take care to replace pressure tap plug.

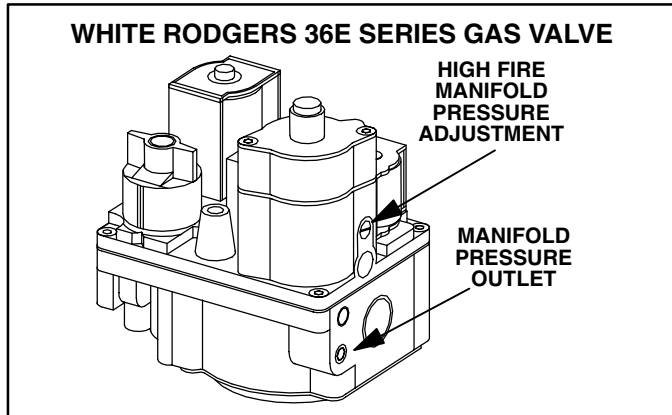

FIGURE 17

F- Proper Gas Flow (Approximate)

Furnace should operate at least 5 minutes before checking gas flow. Determine time in seconds for **two** revolutions of gas through the meter. (Two revolutions assures a more accurate time.) **Divide by two** and compare to time in table 7 below. Adjust manifold pressure on gas valve to match time needed.

NOTE- To obtain accurate reading, shut off all other gas appliances connected to meter.

TABLE 7

GAS METER CLOCKING CHART		
G27M Unit	Seconds for One Revolution	
	Natural	
	1 cu ft Dial	2 cu ft Dial
-60	60	120
-75	48	96
-100	36	72
-120	30	60
Natural-1000 btu/cu ft		

G-High Altitude Derate

Refer to table 8 for high fire manifold pressure settings for installations at different altitudes. For low fire, no manifold pressure adjustment is required.

TABLE 8

Manifold Absolute Pressure (Outlet) in. w.c.

UNIT MODEL	Altitude -- feet (m) above sea level				
	0-2000 (0-610)	2000-4500 (610-1372)	4500-5500 (1372-1676)	5500-6500 (1676-1981)	6500-7500 (1981-2286)
G27M2-60					
G27M3-75	3.5 (0.87)	3.5 (0.87)*	3.4 (0.85)	3.3 (0.82)	3.1 (0.77)
G27M4-100					
G27M5-120					

**No adjustment required.*

NOTE - In Canada, certification for installations at elevations over 4500 feet (1372m) is the jurisdiction of local authorities.

The combustion air pressure switches are factory set and are not to be adjusted.

Factory-installed pressure switches are acceptable for units installed at elevations up to 4500 feet (1372m). Installations at higher elevations require replacement of the high-fire pressure switch. Table 9 outlines pressure switch requirements.

TABLE 9

UNIT MODEL	PRESSURE SWITCH PART NUMBER
G27M2-60A-1	80K4001
G27M3-75A-1	80K4301
G27M4-100A-1	18L2501
G27M5-120A-1	18L2501

⚠ IMPORTANT

For safety, shut unit off and remove manometer as soon as an accurate reading has been obtained. Take care to replace pressure tap plug.

H-Flame Signal

A 20 microamp DC meter is needed to check the flame signal on the SureLight ignition control. Use a flame signal transducer (part number 78H5401) available from Lennox to measure the flame signal.

Flame (microamp) signal is an electrical current which passes from the ignition control through the sensor electrode during unit operation. Current passes from the sensor through the flame to ground to complete a safety circuit.

To Measure Flame Signal:

- 1 - Remove front louvered panel and disconnect the sensor wire from the flame sensor.
- 2 - Place meter in series between flame sensor and sensor wire. Connect the positive (+) lead of meter to the sensor wire and the negative (-) lead of the meter to the flame sensor. Refer to table 10 for flame signal.

TABLE 10

FLAME SIGNAL IN MICROAMPS	
NORMAL	0.8 or More
LOW	0.7 or Less
MINIMUM	0.15 or Less

V-TYPICAL OPERATING CHARACTERISTICS

A-Blower Operation and Adjustment

NOTE- The following is a generalized procedure and does not apply to all thermostat controls.

- 1 - Blower operation is dependent on thermostat control system.
- 2 - Generally, blower operation is set at thermostat sub-base fan switch. With fan switch in ON position, blower operates continuously on low speed. With fan switch in AUTO position, blower cycles with demand or runs continuously while heating or cooling circuit cycles.
- 3 - In all cases, blower and entire unit will be off when the system switch is in OFF position.

B-Temperature Rise

Temperature rise for G27M units depends on unit input, blower speed, blower horsepower and static pressure as marked on the unit rating plate. The blower speed must be set for unit operation within the range of "AIR TEMP. RISE °F" listed on the unit rating plate. Unit must also operate on second-stage heat.

To Measure Temperature Rise:

- 1 - Place plenum thermometers in the supply and return air plenums. Locate supply air thermometer in the first horizontal run of the plenum where it will not pick up radiant heat from the heat exchanger.
- 2 - Set thermostat to highest setting.

- 3 - After plenum thermometers have reached their highest and steadiest readings, subtract the two readings. The difference should be in the range listed on the unit rating plate. If the temperature is too low, decrease blower speed. If temperature is too high, first check the firing rate. Provided the firing rate is acceptable, increase blower speed to reduce temperature. To change blower speed taps see the Blower Speed Taps section in this manual.

C-External Static Pressure

- 1 - Measure tap locations as shown in figure 18.

- 2 - Punch a 1/4" diameter hole in supply and return air plenums. Insert manometer hose flush with inside edge of hole or insulation. Seal around the hose with permagum. Connect the zero end of the manometer to the discharge (supply) side of the system. On ducted systems, connect the other end of manometer to the return duct as above. For systems with non-ducted returns, leave the other end of the manometer open to the atmosphere.

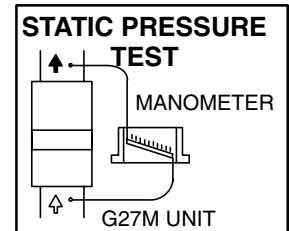

FIGURE 18

- 3 - With only the blower motor running and the evaporator coil dry, observe the manometer reading. Adjust blower motor speed to deliver the air desired according to the job requirements.
- 4 - External static pressure drop must not be more than 0.5" W.C. (124 Pa).
- 5 - Seal around the hole when the check is complete.

D-Blower Speed Taps Leafless Motors

-1 Models

Blower speed tap selection is accomplished by changing the taps at the blower motor harness connector. Disconnect harness connector from motor to expose speed selectors. See table 11 for blower speed tap selection.

To Change Blower Speed:

- 1 - Turn off electric power to furnace.
- 2 - Remove front panel and blower access door.
- 3 - Disconnect blower motor harness from motor.
- 4 - Select desired speeds for heating and cooling. (Red = continues fan and low heat, Yellow = heating, Black = cooling, White = common).
- 5 - Depress harness connector tab to release wire terminal. Select connector location for new speed (refer to unit wiring diagram). Insert wire terminal until it is securely in place. See figure 19.
- 6 - Replace harness connector to motor.

E-Blower Speed Taps Leaded Motors

-2 Models

Blower speed tap changes are made on the SureLight control board. See figure 2. Unused taps must be secured on dummy terminals "PARK M1" and or "PARK M2" on the SureLight board. The heating tap is connected to the "ACB HEAT" terminal and the cooling tap is connected to the "ACB COOL" terminal. The continuous blower tap is connected to the "ACB LOW" terminal.

To change existing heat tap, turn off power then switch out speed tap on "ACB HEAT" with tap connected to "PARK M1" or "PARK M2". See table 12 for blower motor tap colors for each speed.

TABLE 11

BLOWER SPEED CHART					
UNIT	FACTORY CONNECTED SPEED TAPS				MOTOR SPEEDS AVAILABLE
	COOL	HIGH HEAT	LOW HEAT	LOW HEAT & CONT FAN	
Q2-60, Q3-75	2	4	5		4
SPEED TAPS	2	3	4	5	
Q4-100	2	3	4		5
Q5-120	2	4	6		5
SPEED TAPS	2	3	4	5	6

BLOWER SPEED SELECTION
HI ← → LO

TABLE

BLOWER SPEED CHART (LEADED MOTORS)					
UNIT	FACTORY CONNECTED SPEED TAP			MOTOR SPEEDS AVAILABLE	
	COOL	HIGH HEAT	LOW HEAT		
Q2-60, 3-75	BLK	YEL	RED	4	
Q4-100	BLK	BRN	BLUE	5	
Q5-120	BLK	BRN	RED	5	

BLOWER SPEED SELECTION
HI ← → LO

SPEED TAP	BLK	BRN	YEL	RED	4	
	BLK	BRN	BLUE	YEL	RED	5

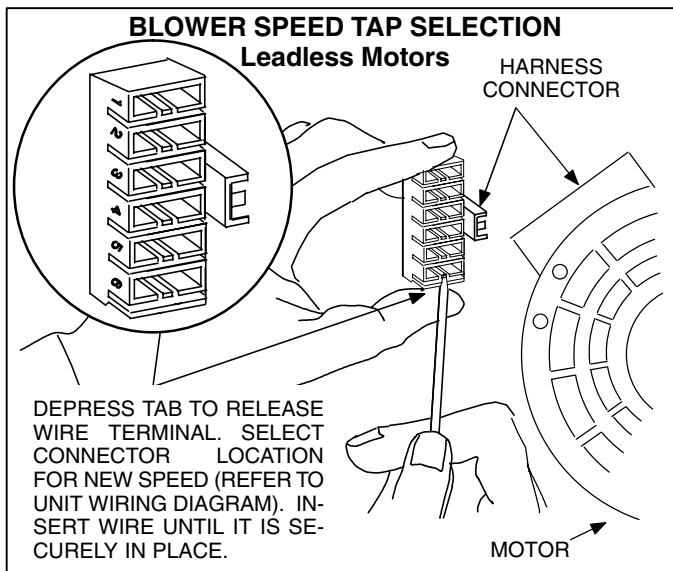

FIGURE 19

VI-MAINTENANCE

⚠ WARNING

Disconnect power before servicing unit.

⚠ CAUTION

Label all wires prior to disconnection when servicing controls. Wiring errors can cause improper and dangerous operation. Verify proper operation after servicing.

At the beginning of each heating season, the system should be checked as follows:

Blowers

Check and clean blower wheels for any debris. Blower motors are prelubricated for extended bearing life. No further lubrication is needed.

Filters

All G27M filters are installed external to the unit. Filters should be inspected monthly and cleaned or replaced when necessary to assure proper furnace operation. See table 13 for filter sizes. Replacement filters for G27M-60/75 units must have a minimum velocity rating of 400 FPM. Replacement filters for G27M-100/120 units require a minimum velocity rating of 625 FPM.

TABLE 13

MODEL NO.	FILTER SIZE	
	UPFLOW / HORIZ. (1 filter)	DOWNFLOW (2 filters)
G27M-60/75	16" x 20" x 1"	16" x 20" x 1"
G27M-100/120	20" x 20" x 1"	16" x 20" x 1"

⚠ WARNING

Blower door must be securely in place when blower and burners are operating. Gas fumes, which could contain carbon monoxide, can be drawn into living space resulting in personal injury or death.

Flue And Chimney

Check flue pipe, chimney and all connections for tightness and to make sure there is no blockage. Draft at flue collar should always be negative.

Burners

Burners and burner flame should be inspected at the beginning of each heating season. Clean burners, if necessary, as outlined below:

- 1 - Turn off electrical and gas supply to unit.
- 2 - Disconnect gas supply piping and remove gas manifold.
- 3 - Disconnect ignitor and flame sensor leads.
- 4 - Remove burner tray and burners.
- 5 - Clean burner retention ring with wire brush as shown in figure 20.
- 6 - Use test tube brush to clean inside of each burner.
- 7 - Replace burners and burner tray, making sure burners are properly seated in slots on tray and orifice in manifold.

- 8 - Reinstall burner box and gas supply piping. Reconnect ignitor and flame sensor leads.
- 9 - Carefully check all piping connections (factory and field) for gas leaks. Use a leak detecting solution or other preferred means.
- 10 - Restore electrical power and gas supply. Follow lighting instructions on front of unit. Check burner flame and adjust if necessary.

⚠ CAUTION

Some soaps used for leak detection are corrosive to certain metals. Carefully rinse piping thoroughly after leak test has been completed. Do not use matches, candles, flame or other sources of ignition to check for gas leaks.

Heat Exchanger

NOTE-Use papers or protective covering in front of furnace while cleaning furnace.

Due to dimples designed in the heatexchanger, cleaning is not recommended. Removal is for inspection only.

Electrical

- 1 - Check all wiring for loose connections.
- 2 - Check for correct voltage at unit (unit operating).
- 3 - Check amp-draw on blower motor.
Motor Nameplate _____ Actual _____

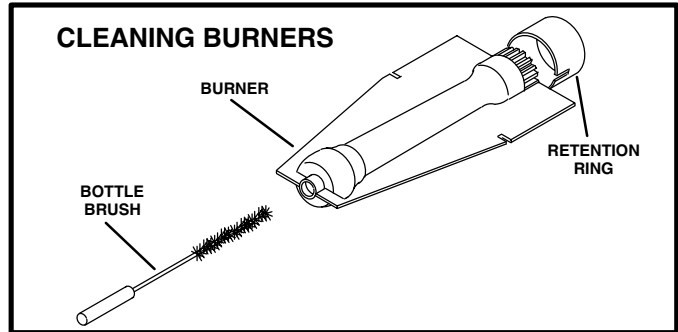

FIGURE 20

HEAT EXCHANGER REMOVAL (unit shown in horizontal position)

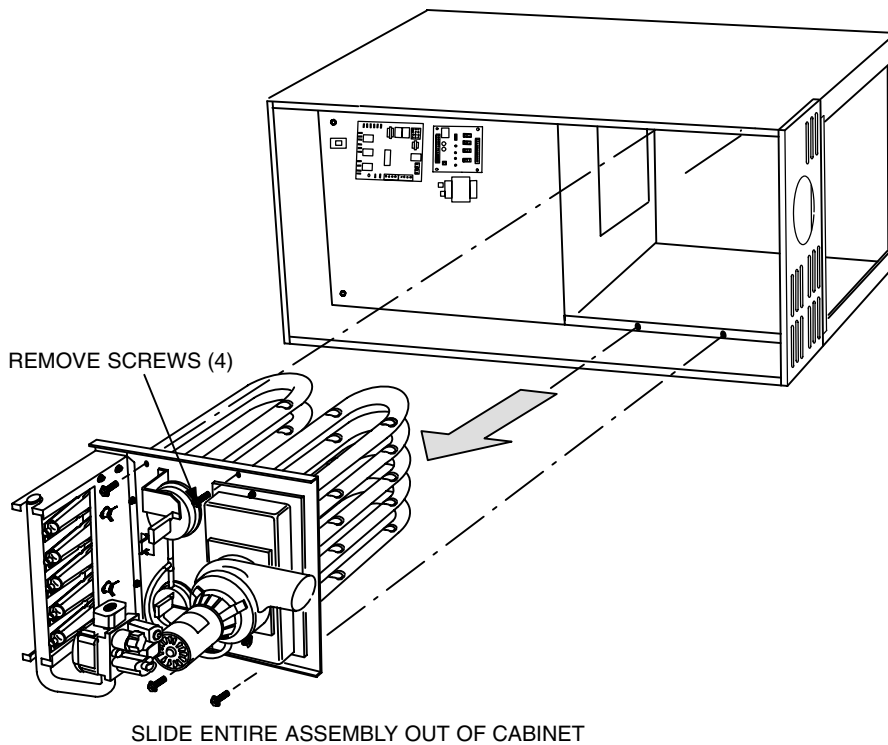
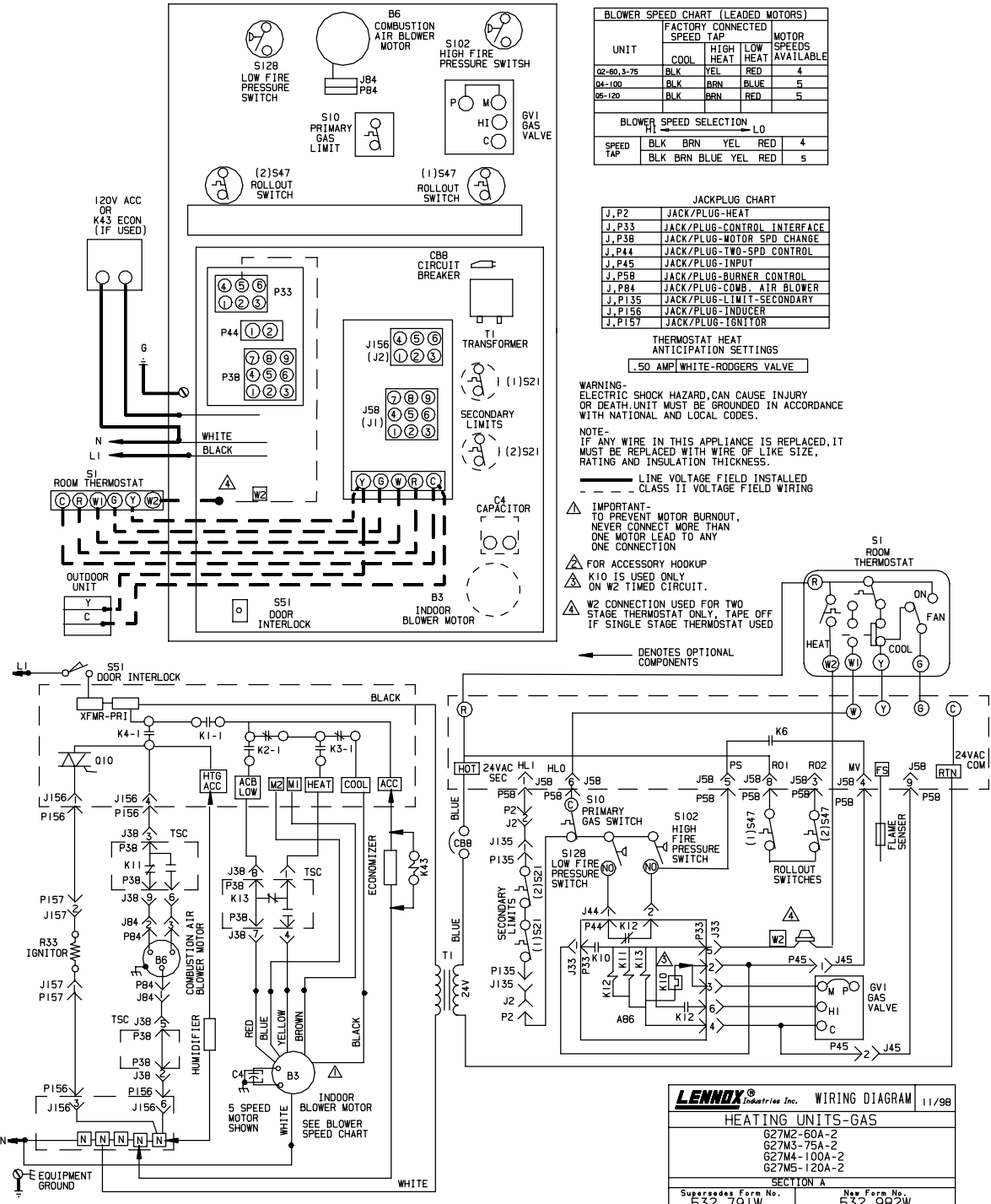

FIGURE 21

VII-WIRING DIAGRAM AND SEQUENCE OF OPERATION

TYPICAL G27M WIRING DIAGRAM (-2 Model 60 Hz. Units Only)



BLOWER SPEED CHART (LEADED MOTORS)

UNIT	FACTORY CONNECTED SPEED TAP			MOTOR SPEEDS AVAILABLE
	COOL	HIGH HEAT	LOW HEAT	
02-80, 3-78	BLK	YEL	RED	4
04-100	BLK	BRN	BLUE	5
05-120	BLK	BRN	RED	5

BLOWER SPEED SELECTION

SPEED TAP	HI					LO				
	BLK	BRN	BLUE	YEL	RED	BLK	BRN	BLUE	YEL	RED
						4				
										5

JACKPLUG CHART

J, P2	JACK/PLUG-HEAT
J, P33	JACK/PLUG-CONTROL INTERFACE
J, P38	JACK/PLUG-MOTOR SPD CHANGE
J, P44	JACK/PLUG-TWO-SPD CONTROL
J, P45	JACK/PLUG-INPUT
J, P58	JACK/PLUG-BURNER CONTROL
J, P84	JACK/PLUG-COMB. AIR BLOWER
J, P135	JACK/PLUG-LIMIT-SECONDARY
J, P156	JACK/PLUG-INDUCER
J, P157	JACK/PLUG-IGNITOR

THERMOSTAT HEAT ANTICIPATION SETTINGS
 .50 AMP WHITE-RODGERS VALVE

WARNING - ELECTRIC SHOCK HAZARD, CAN CAUSE INJURY OR DEATH. UNIT MUST BE GROUNDED IN ACCORDANCE WITH NATIONAL AND LOCAL CODES.

NOTE - IF ANY WIRE IN THIS APPLIANCE IS REPLACED, IT MUST BE REPLACED WITH WIRE OF LIKE SIZE, RATING AND INSULATION THICKNESS.

— LINE VOLTAGE FIELD INSTALLED
 - - - CLASS II VOLTAGE FIELD WIRING

⚠ IMPORTANT - TO PREVENT MOTOR BURNOUT, NEVER CONNECT MORE THAN ONE MOTOR LEAD TO ANY ONE CONNECTION

⚠ FOR ACCESSORY HOOKUP

⚠ K10 IS USED ONLY ON W2 TIMED CIRCUIT.

⚠ W2 CONNECTION USED FOR TWO STAGE THERMOSTAT ONLY, TAPE OFF IF SINGLE STAGE THERMOSTAT USED

← DENOTES OPTIONAL COMPONENTS

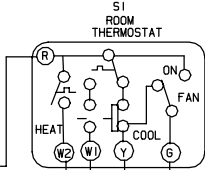

LENNOX Industries Inc. WIRING DIAGRAM 11/98

HEATING UNITS-GAS

G27M2-60A-2
 G27M3-75A-2
 G27M4-100A-2
 G27M5-120A-2

SECTION A

Supersedes Form No. 532, 791W New Form No. 532, 982W

© 1998 Lennox Industries Inc. Litho U.S.A.

Sequence of Operation G27M

Ignitor operation will vary between SureLight boards. Boards 24L85, 56L83 and 63K89, will energize ignitor for the first second of the 4 second ignition trial. Board 97L48 will energize ignitor for the full 4-second ignition trial.

- 1 - When there is a call for heat, W1 of the thermostat energizes W of the furnace control with 24VAC.
- 2 - SureLight control runs self-check for S10 primary limit switch normally closed contacts. The control also checks S128 combustion air prove switch and S102 high fire pressure switch normally open contacts. Follow steps 4 through 8 per respective thermostat.

Single-stage Mode, Single-stage Thermostat

- 3 - SureLight control energizes combustion air blower B6 on high speed. Combustion air blower runs until S102 high fire pressure switch closes (switch will close within 2-1/2 minutes or control goes into Watchguard-Pressure Switch mode). A 15-second pre-purge follows after S102 closes.
- 4 - SureLight control energizes ignitor. A 20-second warm-up period begins.
- 5 - Gas valve is energized on first stage heat (low). Gas valve opens for a 4 second trial for ignition.
- 6 - Flame is sensed. After 8 seconds from when gas valve opens, valve energizes on second stage (high heat).
- 7 - After 45-second delay, indoor blower B3 is energized on heating speed.

Two-stage Mode, Single-stage Thermostat

- 1 - SureLight control energizes combustion air blower B6 on low speed. Combustion air blower runs until combustion air blower switch S128 closes (switch will close within 2-1/2 minutes or control goes into Watchguard-Pressure Switch mode). A 15-second pre-purge follows once S128 closes.
- 2 - SureLight control energizes ignitor. A 20-second warm-up period begins.
- 3 - Gas valve is energized on first stage. Gas valve opens for a 4-second trial for ignition. Signal is sent from control module to two-stage control board to begin W2 (second-stage) ON delay.
- 4 - Flame is sensed, gas valve remains open for the heat call.
- 5 - After 45-second delay, indoor blower B3 is energized on low speed.
- 6 - Second stage time on delay complete (8, 12, or 15 minutes). Combustion air blower B6 switches to high speed, indoor blower B3 switches to heating speed and gas valve opens on high fire (second stage.)

Two-stage Mode, Two-stage Thermostat

- 1 - SureLight control energizes combustion air blower B6 on low speed. Combustion air blower runs until combustion air blower switch S128 closes (switch will close within 2-1/2 minutes or control goes into Watchguard-Pressure Switch mode). A 15-second pre-purge follows once S128 closes.
- 2 - SureLight control energizes ignitor. A 20-second warm-up period begins.
- 3 - Gas valve is energized on first stage only. Gas valve opens for a 4-second trial for ignition.
- 4 - Flame is sensed, gas valve remains open for the heat call.
- 5 - After 45-second delay, indoor blower B3 is energized on low speed.
- 6 - Call for second stage heat comes from indoor thermostat (W2).

HEATING SEQUENCE OF OPERATION

NORMAL HEATING MODE

ABNORMAL HEATING MODE

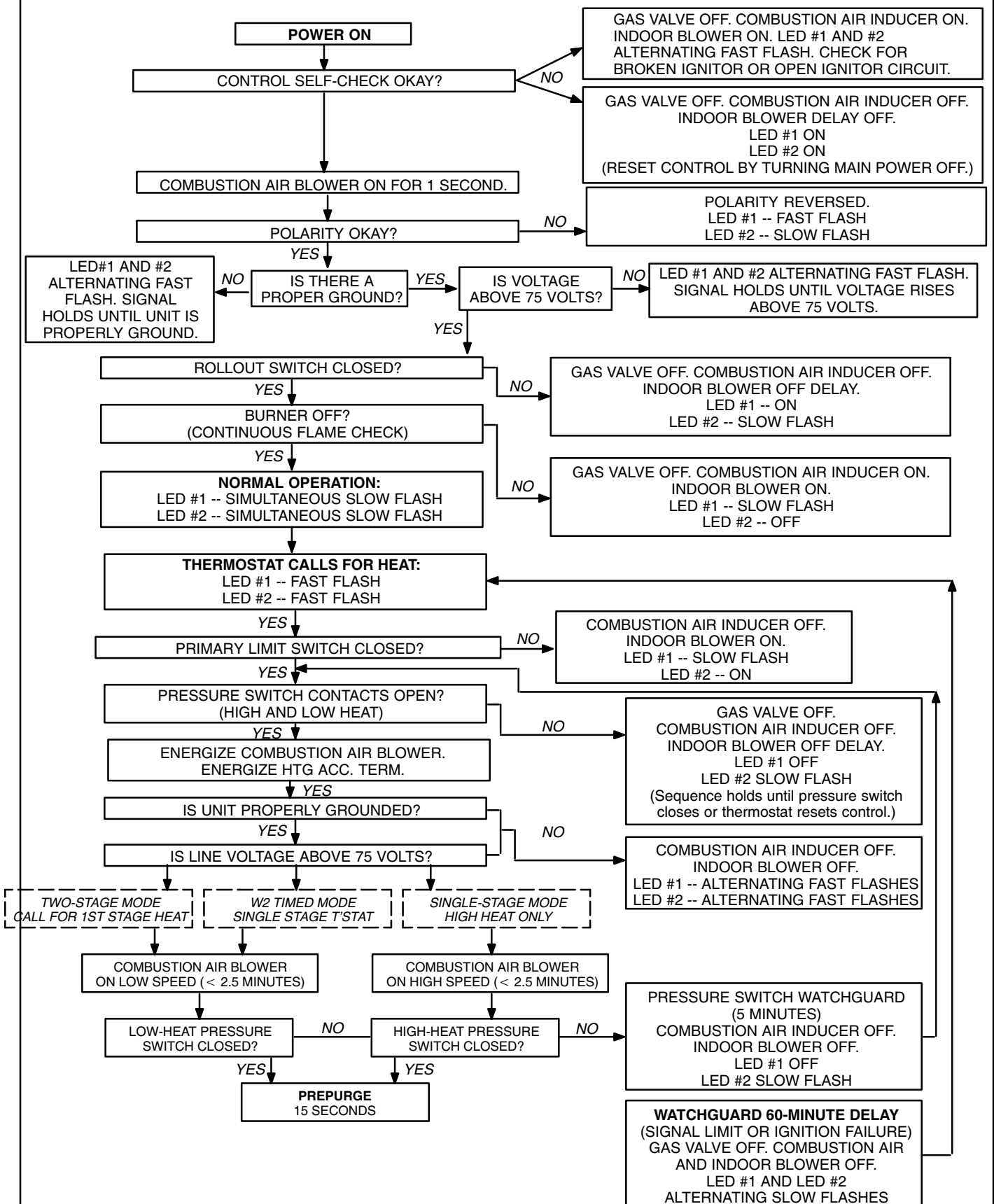

CONTINUED ON NEXT PAGE

HEATING SEQUENCE CONTINUED

NORMAL HEATING MODE

ABNORMAL HEATING MODE

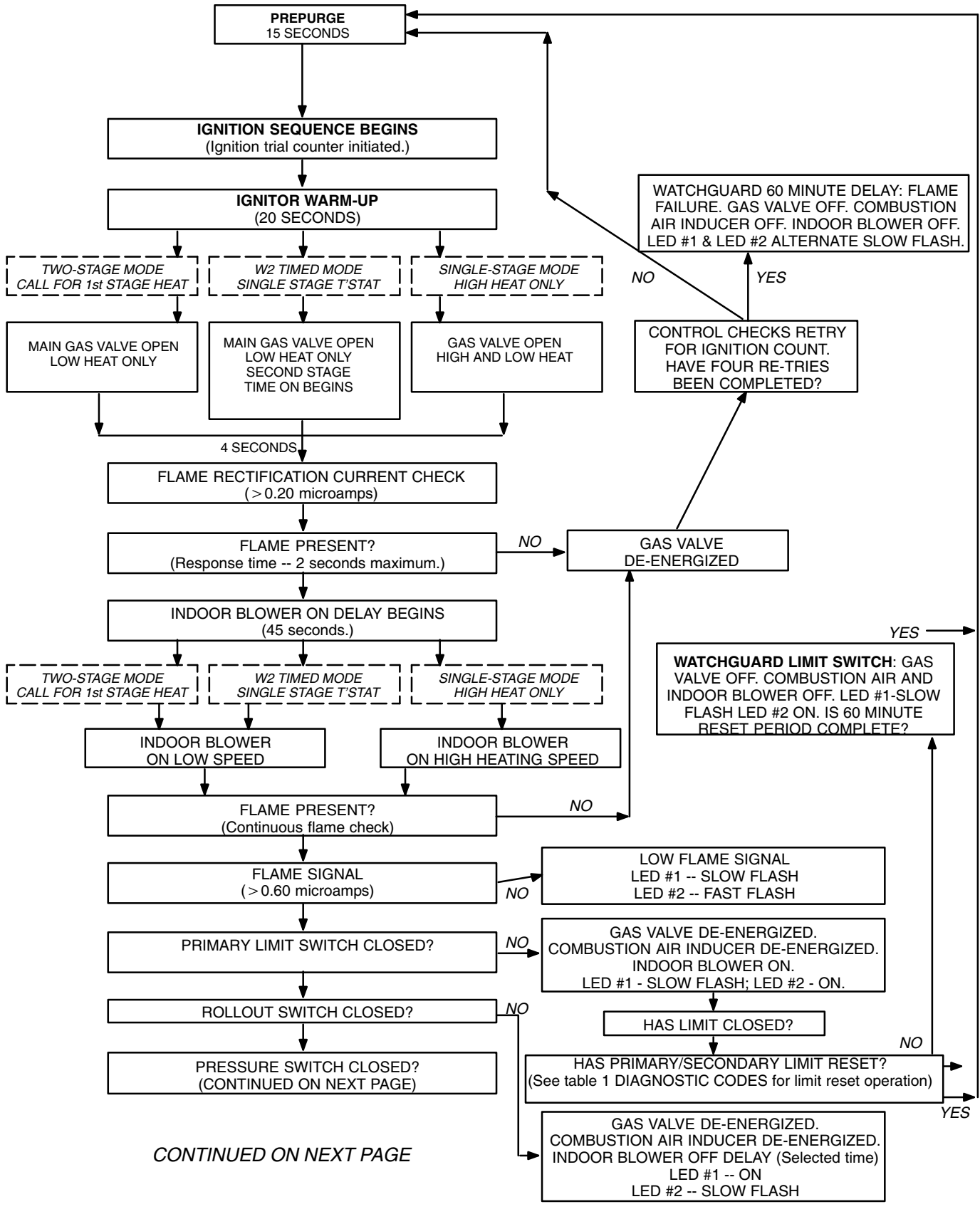

HEATING SEQUENCE CONTINUED

NORMAL HEATING MODE

ABNORMAL HEATING MODE

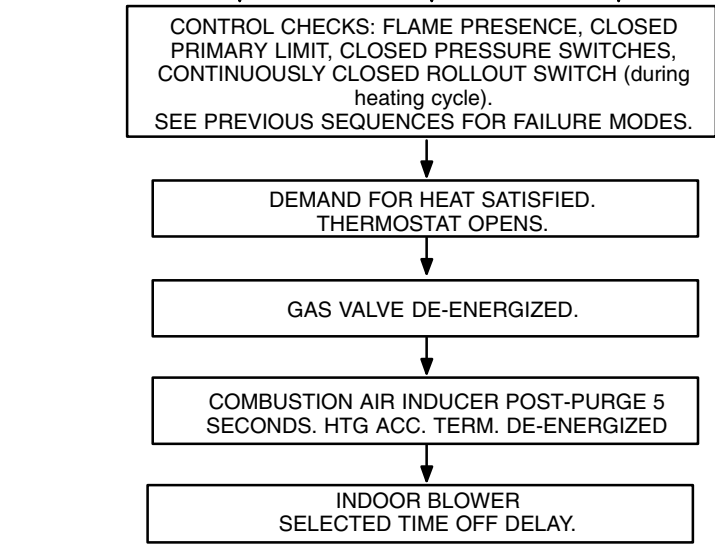
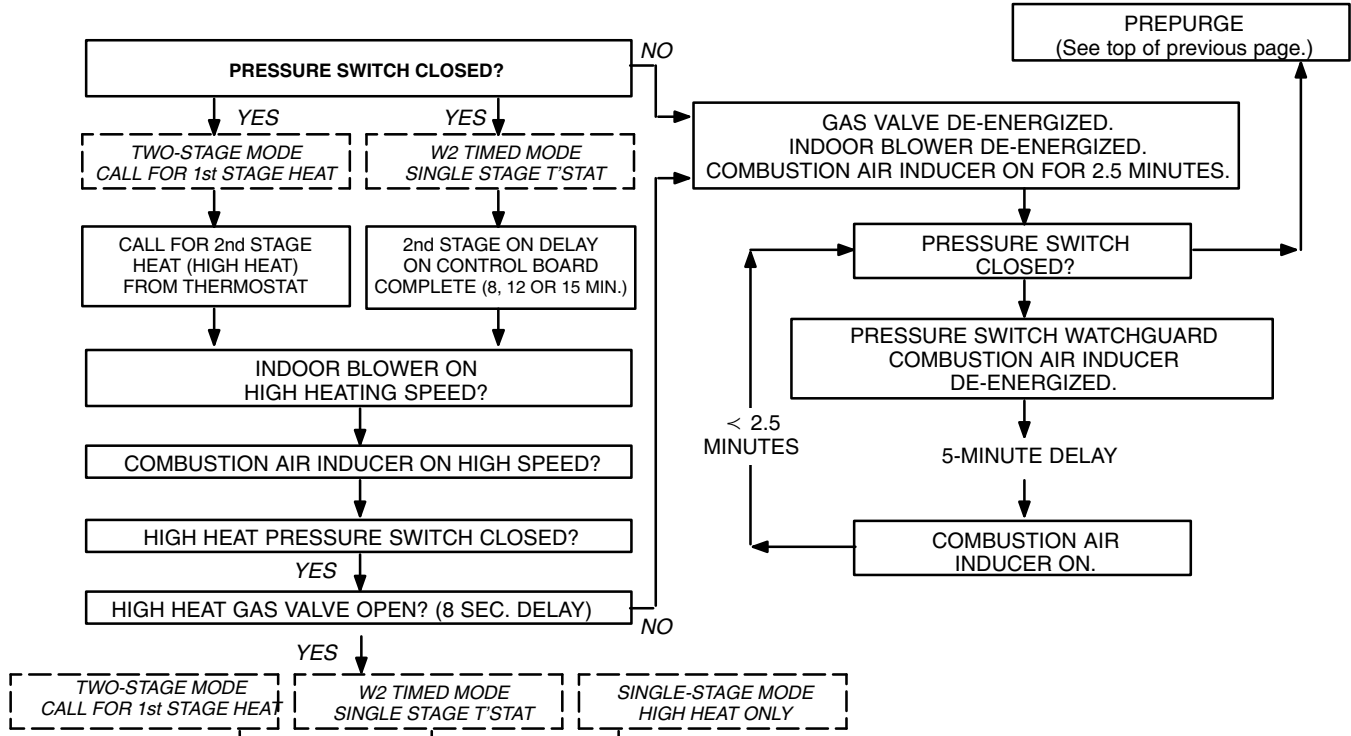

DIAGNOSTIC CODES		
LED #1	LED #2	DESCRIPTION
SLOW FLASH	ON	Primary or secondary limit open
ON	SLOW FLASH	Rollout switch open
SLOW FLASH	OFF	Flame sensed without gas valve energized
OFF	SLOW FLASH	Pressure switch open
SLOW FLASH	SLOW FLASH	Power on
FAST FLASH	FAST FLASH	Heating demand
FAST FLASH	SLOW FLASH	Polarity reversed
SLOW FLASH	FAST FLASH	Low flame signal
ON	ON	Circuit board failure
ALTERNATING SLOW FLASH		Watchguard -- burners failed to ignite
ALTERNATING FAST FLASH		Watchguard -- low voltage, below 75V or improper main ground.

POWER ON COOLING SEQUENCE OF OPERATION

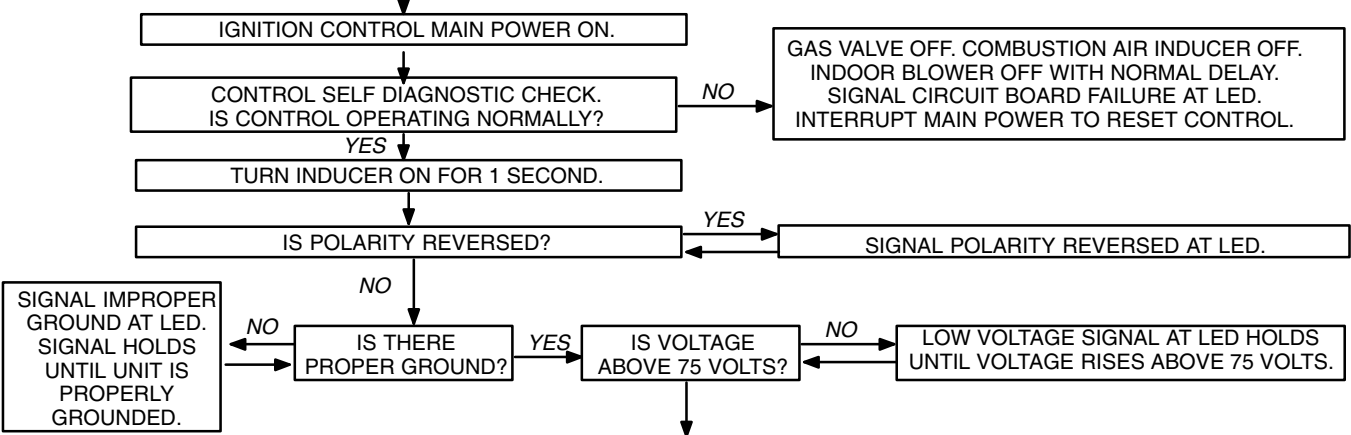

COOLING SEQUENCE CONTINUED

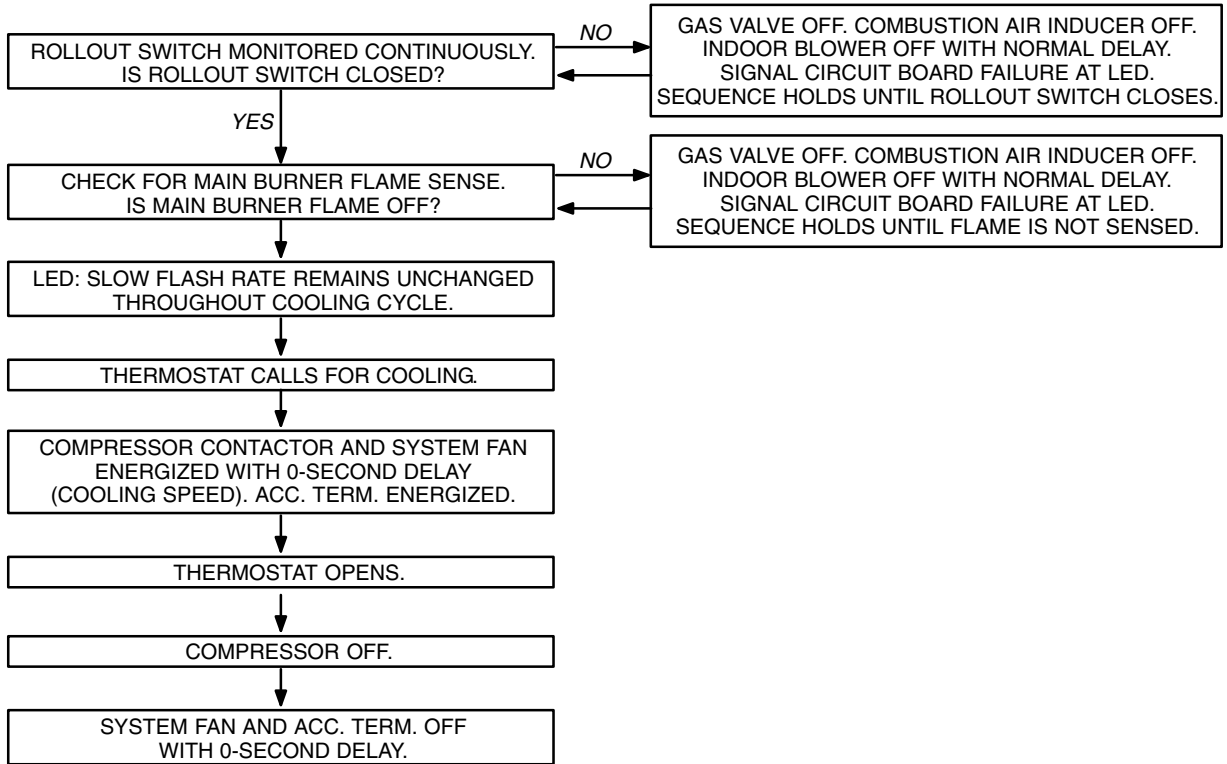

CONTINUOUS LOW SPEED FAN SEQUENCE OF OPERATION

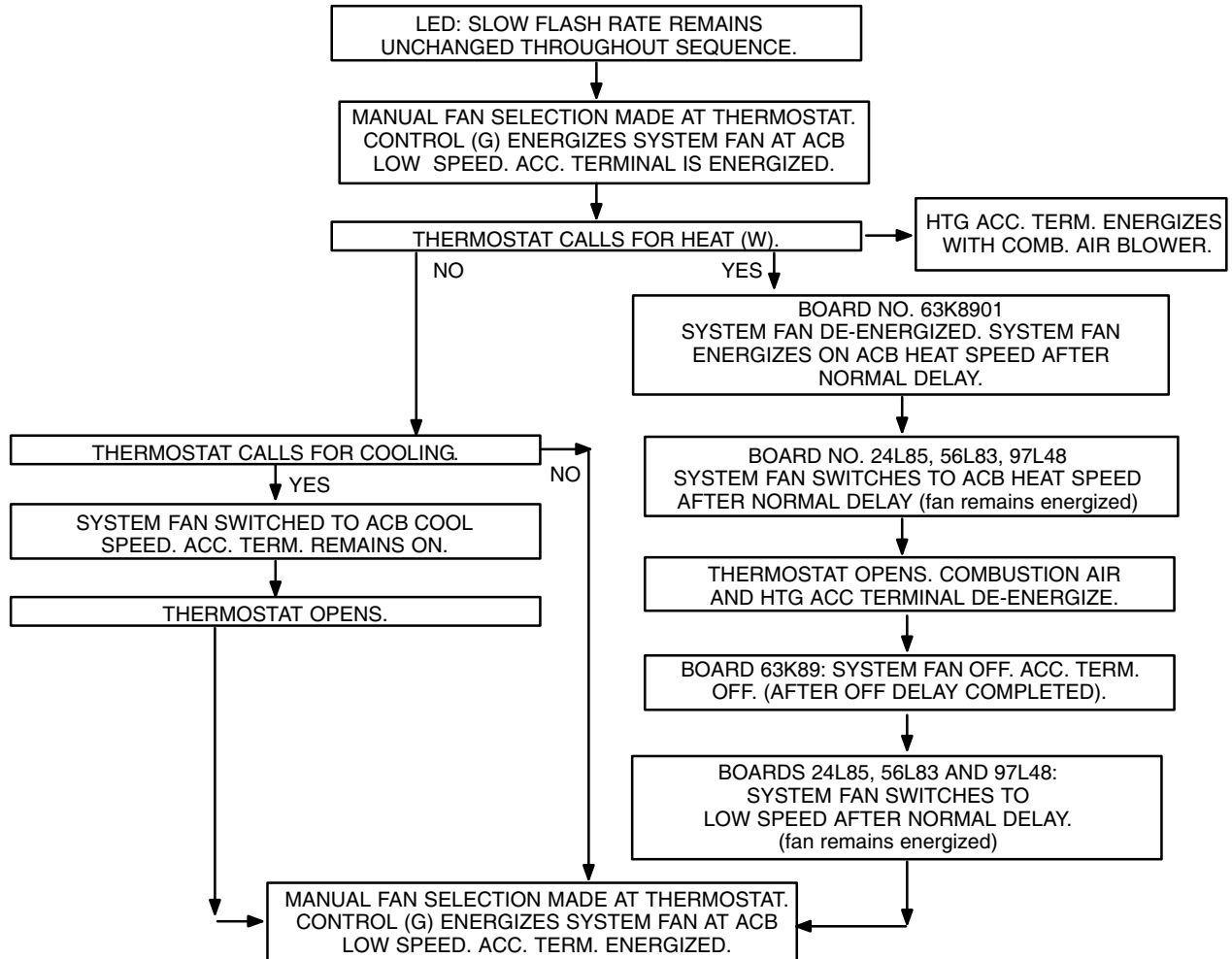

VIII- Troubleshooting Guide SureLight Control

UPON INITIAL POWER UP, REMOVE ALL THERMOSTAT DEMANDS TO THE UNIT

PROBLEM: 1 UNIT FAILS TO OPERATE IN THE COOLING, HEATING, OR CONTINUOUS FAN MODE		
Condition	Possible Cause	Corrective Action / Comments
<p>1.1</p> <p>- Both diagnostic lights fail to light up.</p> <p>LED#1-Off LED#2-Off</p>	<p>1.1.1</p> <p>Main voltage 120V not supplied to unit.</p>	<p>ACTION 1 - Check 120V main voltage. Determine cause of main power failure.</p>
	<p>1.1.2</p> <p>Miswiring of furnace or improper connections.</p>	<p>ACTION 1 - Check for correct wiring of 120V to power make up box and transformer. ACTION 2 - Check 24V wiring to control board.</p>
	<p>1.1.3</p> <p>Circuit breaker tripped or fails to close.</p>	<p>ACTION 1 - Replace circuit breaker if it is reset but does not have continuity. ACTION 2 - If circuit breaker still trips, check for short.</p>
	<p>1.1.4</p> <p>Door interlock switch failure.</p>	<p>ACTION 1 - Check that door switch is activated when door is closed. ACTION 2 - Check wire connections to switch, replace loose connectors. ACTION 3 - Check continuity of switch in closed position. Replace if malfunctioning</p>
	<p>1.1.5</p> <p>Transformer Failure.</p>	<p>ACTION 1 - Check that transformer output is 24V. Replace if malfunctioning</p>
	<p>1.1.6</p> <p>Failed control board.</p>	<p>ACTION 1 - If all the above items have been checked, replace board.</p>
<p>1.2</p> <p>- Diagnostic lights flash the roll-out code.</p> <p>LED#1-On, LED#2-Slow Flash</p>	<p>1.2.1</p> <p>Roll-out switch open.</p>	<p>ACTION 1 - Manually reset the roll-out switch by pushing the top button. ACTION 2 - Determine the cause of the roll-out switch activation before leaving furnace.</p>
	<p>1.2.2</p> <p>Roll-out switch failure.</p>	<p>ACTION 1 - Check continuity across roll-out switch. Replace roll-out switch if switch is reset but does not have continuity.</p>
	<p>1.2.3</p> <p>Miswiring or improper connections at roll-out switch.</p>	<p>ACTION 1 - Check wiring connections to switch.</p>
	<p>1.2.4</p> <p>Nine pin connector failure</p>	<p>ACTION 1 - Check 9-pin connector for proper connection to control board. ACTION 2 - Check continuity of the multi plug pin.</p>
<p>1.3</p> <p>- On initial power-up the comb. air blower does not energize. - Diagnostic lights flash the reverse polarity code.</p> <p>LED#1-Fast Flash, LED#2-Slow Flash.</p>	<p>1.3.1</p> <p>120V main power polarity reversed.</p>	<p>ACTION 1 - Check the 120V has line and neutral correctly input into control. ACTION 2 - Reverse the line and neutral at the 120V field connection.</p>
<p>1.4</p> <p>- On initial power up the combustion air blower does not energize. - Diagnostic lights flash normal power on operation.</p> <p>LED#1-Slow Flash LED#2-Slow Flash</p>	<p>1.4.1</p> <p>Open combustion air blower motor circuit.</p>	<p>ACTION 1 - Check for 120V to combustion air blower. If no power, check wire and connections.</p>
	<p>1.4.2</p> <p>Failed combustion air blower motor.</p>	<p>ACTION 1 - If power is present at blower, replace blower.</p>

PROBLEM 1: UNIT FAILS TO OPERATE IN THE COOLING, HEATING, OR CONTINUOUS FAN MODE

Condition	Possible Cause	Corrective Action / Comments
<p>1.5</p> <ul style="list-style-type: none"> - On initial power-up the combustion air blower remains energized. - Diagnostic lights flash the improper main ground. <p>LED#1-Alternating Fast Flash LED#2-Alternating Fast Flash</p>	<p>1.5.1</p> <p>Improper ground to the unit.</p>	<p>ACTION 1 - Check that the unit is properly grounded. ACTION 2 - Install a proper main ground to the unit</p>
	<p>1.5.2</p> <p>6-Pin connector is improperly attached to the circuit board.</p>	<p>ACTION 1 - Check 6-pin connector for proper installation. Correctly insert connector into control.</p>
	<p>1.5.3</p> <p>Line voltage is below 75V.</p>	<p>ACTION 1 - Check that the line voltage is above 75V. Determine cause of voltage drop and supply correct voltage to the control.</p>

PROBLEM 2: UNIT FAILS TO OPERATE IN THE COOLING OR HEATING MODE, BUT COMBUSTION AIR BLOWER OPERATES CONTINUOUS. UNITS WITH CONTROL BOARDS DATE CODED AFTER NOV.1 1997, WILL OPERATE IN COOLING WITH COMBUSTION AIR BLOWER CYCLING 5 SECONDS ON 55 SECONDS OFF, BUT NOT IN THE HEATING MODE.

Condition	Possible Cause	Corrective Action / Comments
<p>2.1</p> <ul style="list-style-type: none"> - On initial power-up the combustion air blower remains energized. - Diagnostic lights flash the improper main ground. - Units with control boards date coded after Nov.1 1997; combustion air blower will cycle 5 seconds on 55 seconds off. <p>LED#1-Alternating Fast Flash LED#2-Alternating Fast Flash</p>	<p>2.1.1</p> <p>Open ignitor circuit.</p>	<p>ACTION 1 - Check for correct wiring and loose connections in the ignitor circuit. Check multi - plug connections for correct installation.</p>
	<p>2.1.2</p> <p>Broken or failed ignitor.</p>	<p>ACTION 1 - Unplug ignitor and read resistance across ignitor. If resistance does not read between 10.9 and 19.7 ohms, replace the ignitor.</p>

PROBLEM 3: UNIT FAILS TO FIRE IN THE HEATING MODE, COMBUSTION AIR BLOWER DOES NOT ENERGIZE

Condition	Possible Cause	Corrective Action / Comments
<p>3.1</p> <ul style="list-style-type: none"> - Unit operates with a cooling or continuous fan demand. - Combustion air blower will not start with a Heating demand. - Diagnostic lights flash the limit failure mode. <p>LED#1-Slow Flash, LED#2-On</p>	<p>3.1.1</p> <p>Primary or secondary (if equipped) limit open.</p>	<p>ACTION 1 - Check continuity across switch(es). Switches reset automatically upon cool down. ACTION 2-Check for restrictions on blower inlet air (including filter) and outlet air. Determine cause for limit activation before placing unit back in operation.</p>
	<p>3.1.2</p> <p>Miswiring of furnace or improper connections at limit switch(es).</p>	<p>ACTION 1 - Check for correct wiring and loose connections. Correct wiring and/or replace any loose connections.</p>
<p>3.2</p> <ul style="list-style-type: none"> - Unit operates with a cooling and continuous fan demand. - Combustion air blower will not start with a Heating demand. - Diagnostic lights flash the pressure switch failure code. <p>LED#1-Off, LED#2-Slow Flash</p>	<p>3.2.1</p> <p>Miswiring of furnace or improper connections to combustion air blower.</p>	<p>ACTION 1 - Check for correct wiring and loose connections. Correct wiring and/or replace any loose connections.</p>
	<p>3.2.2</p> <p>Pressure switch stuck closed.</p>	<p>ACTION 1 - Check that the pressure switch is open without the combustion air blower operating. Replace if malfunctioning</p>

PROBLEM 3: UNIT FAILS TO FIRE IN THE HEATING MODE, COMBUSTION AIR BLOWER DOES NOT ENERGIZE (CONT.).

Condition	Possible Cause	Corrective Action/Comments
3.3	3.3.1	
- Unit operates with a cooling and continuous fan demand. - Combustion air blower will not start with a Heating demand. - Diagnostic lights flash the pressure switch failure code 2.5 minutes after heating demand. LED#1-Off, LED#2-Slow Flash	Miswiring of furnace or improper connections to combustion air blower.	ACTION 1 - Check for correct wiring and loose connections. Correct wiring and/or replace any loose connections.
	3.3.2	
	Combustion air blower failure.	ACTION 1 - If there is 120V to combustion air blower and it does not operate, replace combustion air blower.

PROBLEM 4: UNIT FAILS TO FIRE IN THE HEATING MODE, COMBUSTION AIR BLOWER ENERGIZES, IGNITOR IS NOT ENERGIZED.

Condition	Possible Cause	Corrective Action/Comments
4.1	4.1.1	
- Unit operates with a cooling and continuous fan demand. - Combustion air blower energizes with a heating demand. - Diagnostic lights flash the pressure switch failure code 2.5 minutes after heating demand. LED#1-Off LED#2-Slow Flash	Pressure switch does not close due to incorrect routing of the pressure switch tubing.	ACTION 1 - Check that the pressure switch tubing is correctly routed. Correctly route pressure switch tubing.
	4.1.2	
	Pressure switch does not close due to obstructions in the pressure tubing.	ACTION 1 - Remove any obstructions from the pressure tubing and/or taps.
	4.1.3	
	Pressure switch tubing damaged	ACTION 1 - Check pressure switch tubing for leaks. Replace any broken tubing.
	4.1.4	
	Condensate in pressure switch tubing.	ACTION 1 - Check pressure switch tubing for condensate. Remove condensate from tubing. Check that the condensate tubing is located correctly.
	4.1.5	
Pressure switch does not close due to a low differential pressure across the pressure switch.	ACTION 1 - Check the differential pressure across the pressure switch. This pressure should exceed the set point listed on the switch. ACTION 2 - Check for restricted inlet and exhaust vent. Remove all blockage. ACTION 3 - Check for proper vent sizing and run length. See installation instructions.	
4.1.6		
Wrong pressure switch installed in the unit, or pressure switch is out of calibration.	ACTION 1 - Check that the proper pressure switch is installed in the unit. Replace pressure switch if necessary.	
4.1.7		
Miswiring of furnace or improper connections at pressure switch.	ACTION 1 - Check for correct wiring and loose connections. Correct wiring and/or replace any loose connections.	
4.1.8		
Pressure switch failure.	ACTION 1 - If all the above modes of failure have been checked, the pressure switch may have failed. Replace pressure switch and determine if unit will operate.	

PROBLEM 5: UNIT FAILS TO FIRE IN THE HEATING MODE, COMBUSTION AIR BLOWER ENERGIZES, IGNITOR IS ENERGIZED. (CONT.)

Condition	Possible Cause	Corrective Action/Comments
<p align="center">5.1</p> <ul style="list-style-type: none"> - Unit operates with a cooling and continuous fan demand. - Combustion air blower energizes with Heating demand. - Ignitor is energized but unit fails to light. <p>LED#1-Alternating Slow Flash LED#2-Alternating Slow Flash</p>	5.1.1 Check that gas is being supplied to the unit.	ACTION 1 - Check line pressure at the gas valve. Pressure should not exceed 13" WC for both natural and propane. Line pressure should read a minimum 4.5" WC for natural and 8.0"WC for propane.
	5.1.2 Miswiring of gas valve or loose connections at multi-pin control amp plugs or valve.	ACTION 1 - Check for correct wiring and loose connections. Correct wiring and/or replace any loose connections.
	5.1.3 Malfunctioning gas valve or ignition control.	ACTION 1 - Check that 24V is supplied to the gas valve approximately 35 seconds after heat demand is initiated. ACTION 2 - Replace the valve if 24V is supplied but valve does not open (check for excessive gas line pressure before replacing gas valve). ACTION 3 - Replace the control board if 24V is not supplied to valve.

PROBLEM 6: BURNERS LIGHT WITH A HEATING DEMAND BUT UNIT SHUTS DOWN PREMATURELY

Condition	Possible Cause	Corrective Action/Comments
<p align="center">6.1</p> <ul style="list-style-type: none"> - Burners fire with a heating demand. - Burners light but unit shuts off prior to satisfying T-stat demand. - Diagnostic lights flash the pressure switch code. <p>LED#1-Off LED#2-Slow Flash</p>	6.1.1 Wrong concentric vent kit used for terminating the unit.	ACTION 1 - Check vent termination kit installed. 1-1/2" dia. concentric vent (kit60G77) for 50 and 75 inputs and 2" dia. concentric vent (kit 33K97) for 100 & 125 inputs.
	6.1.2 Condensate drain line is not draining properly.	ACTION 1 - Check condensate line for proper vent slope, and any blockage. Condensate should flow freely during operation of furnace. Repair or replace any improperly installed condensate lines.
	6.1.3 Low pressure differential at the pressure switch.	ACTION 1 - Check for restricted vent inlet or exhaust. Remove all blockage. ACTION 2: Check for proper vent sizing. See installation instructions.
<p align="center">6.2</p> <ul style="list-style-type: none"> - Combustion air blower energizes with a heating demand. - Burners light but fail to stay lit. - After 5 tries the control diagnostics flash the watchdog burners failed to ignite code. <p>LED#1-Alternating Slow Flash LED#2-Alternating Slow Flash</p>	6.2.1 Sensor or sense wire is improperly installed.	ACTION 1 - Check that sensor is properly located (page 10) and that the sense wire is properly attached to both the sensor and the control.
	6.2.2 Sensor or sense wire is broken.	ACTION 1 - Check for a broken sensor. ACTION 2 - Test continuity across the sense wire. If wire or sensor are damaged replace the component.
	6.2.3 Sensor or sensor wire is grounded to the unit.	ACTION 1 - Check for resistance between the sensor rod and the unit ground. ACTION 2 - Check for resistance between the sensor wire and the unit ground. ACTION 3 - Correct any shorts found in circuit.
	6.2.4 Control does not sense flame.	ACTION 1 - Check the microamp signal from the burner flame. If the microamp signal is below 0.70 microamps, check the sense rod for proper location or contamination. ACTION 2 - Replace, clean, or relocate flame sense rod. If rod is to be cleaned, use steel wool or replace sensor. DO NOT CLEAN ROD WITH SAND PAPER. SAND PAPER WILL CONTRIBUTE TO THE CONTAMINATION PROBLEM. NOTE: Do not attempt to bend sense rod.

PROBLEM 6: BURNERS LIGHT WITH HEATING DEMAND BUT UNIT SHUTS DOWN PREMATURELY (CONT.)

Condition	Possible Cause	Corrective Action/Comments
<p align="center">6.3</p> <ul style="list-style-type: none"> - Combustion air blower energizes with a heating demand. - Burners light. - Roll-out switch trips during the heating demand. - Diagnostic lights flash roll-out failure. <p>LED#1-On LED#2-Slow Flash</p>	<p align="center">6.3.1</p> <p align="center">Unit is firing above 100% of the nameplate input.</p>	<p>ACTION 1 - Check that the manifold pressure matches value listed on nameplate. See installation instructions for proper procedure.</p> <p>ACTION 2 - Verify that the installed orifice size match the size listed on the nameplate or installation instructions.</p> <p>ACTION 3 - Check gas valve sensing hose to insure no leaks are present.</p> <p>ACTION 4 - Check the input rate to verify rate matches value listed on nameplate.</p>
	<p align="center">6.3.2</p> <p align="center">Gas orifices leak at the manifold connection.</p>	<p>ACTION 1 - Tighten orifice until leak is sealed.</p> <p>NOTE: Be careful not to strip orifice threads. ACTION 2 - Check for gas leakage at the threaded orifice connection. Use approved method for leak detection (see unit instructions).</p>
	<p align="center">6.3.3</p> <p align="center">Air leakage at the connections between the primary heat exchanger, secondary heat exchanger, and combustion air blower.</p>	<p>ACTION 1 - Check for air leakage at all joints in the heat exchanger assembly. Condition may cause high CO₂ with high CO.</p> <p>ACTION 2 - Seal leakage if possible (high temperature silicon is recommended), replace heat exchanger if necessary, tag and return heat exchanger to proper Lennox personnel.</p>
	<p align="center">6.3.4</p> <p align="center">Insufficient flow through the heat exchanger caused by a sooted or restricted heat exchanger.</p>	<p>ACTION 1 - Check for sooting deposits or other restrictions in the heat exchanger assembly. Clean assembly as outlined in instruction manual.</p> <p>ACTION 2 - Check for proper combustion and flow. CO should measure below .04% (400PPM) in an air-free sample of flue gases.</p>
	<p align="center">6.3.5</p> <p align="center">Burners are not properly located in the burner box.</p>	<p>ACTION 1 - Check that the burners are firing into the center of the heat exchanger openings. Correct the location of the burners if necessary.</p>
<p align="center">6.4</p> <ul style="list-style-type: none"> - Combustion air blower energizes with a heating demand. - Burners light roughly and the unit fails to stay lit. - Diagnostic lights flash watchguard flame failure. <p>LED#1-Alternating Slow Flash LED#2-Alternating Slow Flash</p>	<p align="center">6.4.1</p> <p align="center">Recirculation of flue gases. This condition causes rough ignitions and operation. Problem is characterized by nuisance flame failures.</p>	<p>ACTION 1 - Check for proper flow of exhaust gases away from intake vent. Remove any obstacles in front of the intake and exhaust vent which would cause recirculation.</p> <p>ACTION 2 - Check for correct intake and exhaust vent installation. See instructions</p>
	<p align="center">6.4.2</p> <p align="center">Improper burner cross-overs</p>	<p>ACTION 1 - Remove burner and inspect the cross-overs for burrs, or any restriction or if crossover is warped. Remove restriction or replace burners.</p>

PROBLEM 6: BURNERS LIGHT WITH HEATING DEMAND BUT UNIT SHUTS DOWN PREMATURELY (CONT.)

<p align="center">6.5</p> <ul style="list-style-type: none"> - Combustion air blower energizes with a heating demand. - Burners light. - Diagnostic lights flash watch guard flame failure. - NOTE” Unit might go into 60 minute Watchguard mode depending on intermittent nature of sensor signal. <p>LED#1-Alternating Slow Flash LED#2-Alternating Slow Flash</p>	<p align="center">6.5.1</p> <p align="center">Loose sensor wire connection causes intermittent loss of flame signal.</p>	<p>ACTION 1 - Check that the sensor is properly located.</p> <p>ACTION 2 - Check that the sense wire is properly attached to both the sensor and the control. Pay extra attention to the pin connectors.</p>
---	---	--

PROBLEM 7: CONTROL SIGNALS LOW FLAME SENSE DURING HEATING MODE

Condition	Possible Cause	Corrective Action/Comments
<p align="center">7.0</p> <ul style="list-style-type: none"> - Unit operates correctly but the diagnostic lights flash low flame sense code. <p>LED#1-Slow Flash LED#2-Fast Flash</p>	<p align="center">7.1.1</p> <p align="center">Sense rod is improperly located on the burner.</p>	<p>ACTION 1 - Check the sense rod for proper location on the burner. Properly locate the sense rod or replace if rod cannot be located correctly.</p>
	<p align="center">7.1.2</p> <p align="center">Sense rod is contaminated.</p>	<p>ACTION 1 - Check sense rod for contamination or coated surface. Clean the sense rod with steel wool or replace sensor. DO NOT USE SAND PAPER TO CLEAN ROD. SAND PAPER WILL CONTRIBUTE TO THE CONTAMINATION PROBLEM.</p>

PROBLEM 8: INDOOR BLOWER FAILS TO OPERATE IN COOLING, HEATING, OR CONTINUOUS FAN MODE

Condition	Possible Cause	Corrective Action/Comments
<p align="center">8.0</p> <ul style="list-style-type: none"> - Indoor blower fails to operate in continuous fan, cooling, or heating mode. 	<p align="center">8.1.1</p> <p align="center">Miswiring of furnace or improper connections at control or indoor blower motor.</p>	<p>ACTION 1 - Correct wiring and/or replace any loose connections. Check for correct wiring and loose connections.</p>
	<p align="center">8.1.2</p> <p align="center">120V is not being supplied to the indoor air blower or blower motor failure.</p>	<p>ACTION 1 - Check for 120V at the various calls for indoor blower by energizing "Y", "G", and "W" individually on the low voltage terminal strip. Note that when "W" is energized, the blower is delayed 45 seconds. If there is 120V to each motor tap but the blower does not operate, replace the motor.</p>
	<p align="center">8.1.3</p> <p align="center">Defective control board</p>	<p>ACTION 1 - If there is not 120V when "Y", "G", or "W" is energized, replace the control.</p>

PROBLEM 9: RF STATIC DURING TIME FOR IGNITION

Condition	Possible Cause	Corrective Action/Comments
<p align="center">9.0</p> <ul style="list-style-type: none"> - AM radio interference 	<p align="center">9.1.2</p> <p align="center">Ignitor operation</p>	<p>ACTION 1- Call Technical Support, Dallas</p>