

### GH19 SERIES UNITS

GH19 series units are mid-efficiency horizontal gas furnaces with heat exchangers formed of aluminized steel. Units come in heating capacities of 50,000 to 125,000 Btuh input. In cooling applications, blowers are equipped to handle up to 5 tons of cooling capacity. Refer to Engineering Handbook for proper sizing.

All units use induced draft combustion with inshot burners and are equipped with electronic intermittent pilot ignition. A combustion air prove switch ensures combustion air blower operation before gas valve can open. Units are factory supplied for use with natural gas. A conversion kit to LPG operation is available. All models meet the California Nitrogen Oxides (NO<sub>x</sub>) Standards and California Seasonal Efficiency requirements without modification. All units use a redundant gas valve to assure safety shut-off as required by A.G.A. GH19 units are manufactured for Lennox by The Ducane Company.

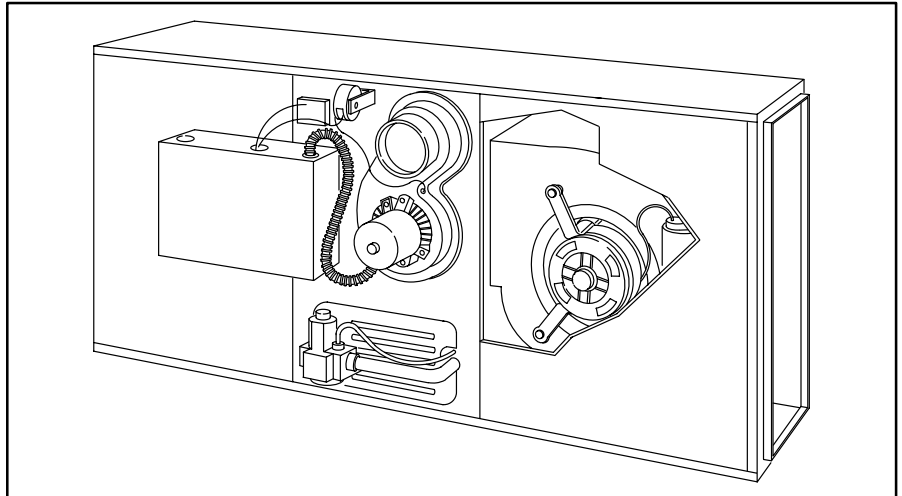

All major components (indoor blower, coils and duct) must be matched and installed according to Lennox recommendations for system components to be covered under warranty. Refer to the Engineering Handbook for approved system matchups. A misapplied system will cause erratic operation and can result in early component failure. Specifications in this manual are subject to change.

Model No.		GH19Q3-50	GH19Q3-75	GH19Q4-75	GH19Q3/4-100	GH19Q4/5-100	GH19Q4/5-125	
Input Btuh		50,000	75,000	75,000	100,000	100,000	125,000	
Output Btuh		40,000	60,000	60,000	80,000	80,000	100,000	
*A.F.U.E.		80.0%	80.0%	80.0%	80.0%	80.0%	80.0%	
California Seasonal Efficiency		76.0%	75.5%	72.0%	75.0%	73.7%	74.0%	
Flue size connection (in.) diameter		4	4	4	4	4	4	
Temperature rise range (°F)		40-70	40-70	30-60	40-70	30-60	40-70	
High static certified by A.G.A. (in wg.)		.50	.50	.80	.50	.50	.50	
Gas Piping Size I.P.S. (in.)	Natural	1/2	1/2	1/2	1/2	1/2	1/2	
	**LPG	1/2	1/2	1/2	1/2	1/2	1/2	
Blower wheel nominal dia. x width (in.)		10 x 8	10 x 8	12 x 8	10 x 9	12 x 9	12 x 12	
Blower motor hp		1/3	1/3	1/2	1/3	3/4	1/2	
Tons of cooling that can be added		1-1/2 — 3	1-1/2 — 3	2 — 4	3 — 4	3 — 5	3 — 5	
Electrical characteristics		115 volts — 60 hertz — 1 phase (less than 12 amps) All models						
**LPG kit (Optional)		85H86 (All Models)						
•Filter Rack Kit (Optional)	Order No.	85H87		85H88		85H89		
	Media cut size (in.)	(1) 23 x 13 x 1/2		(1) 23 x 16-1/2 x 1/2		(1) 23 x 20 x 1/2		

• Field installed

\* Annual Fuel Utilization Efficiency based on D.O.E. test procedures and according to F.T.C. labeling requirements. Isolated combustion system rating for non-weatherized furnaces.

\*\*LPG kit must be ordered extra for field changeover.

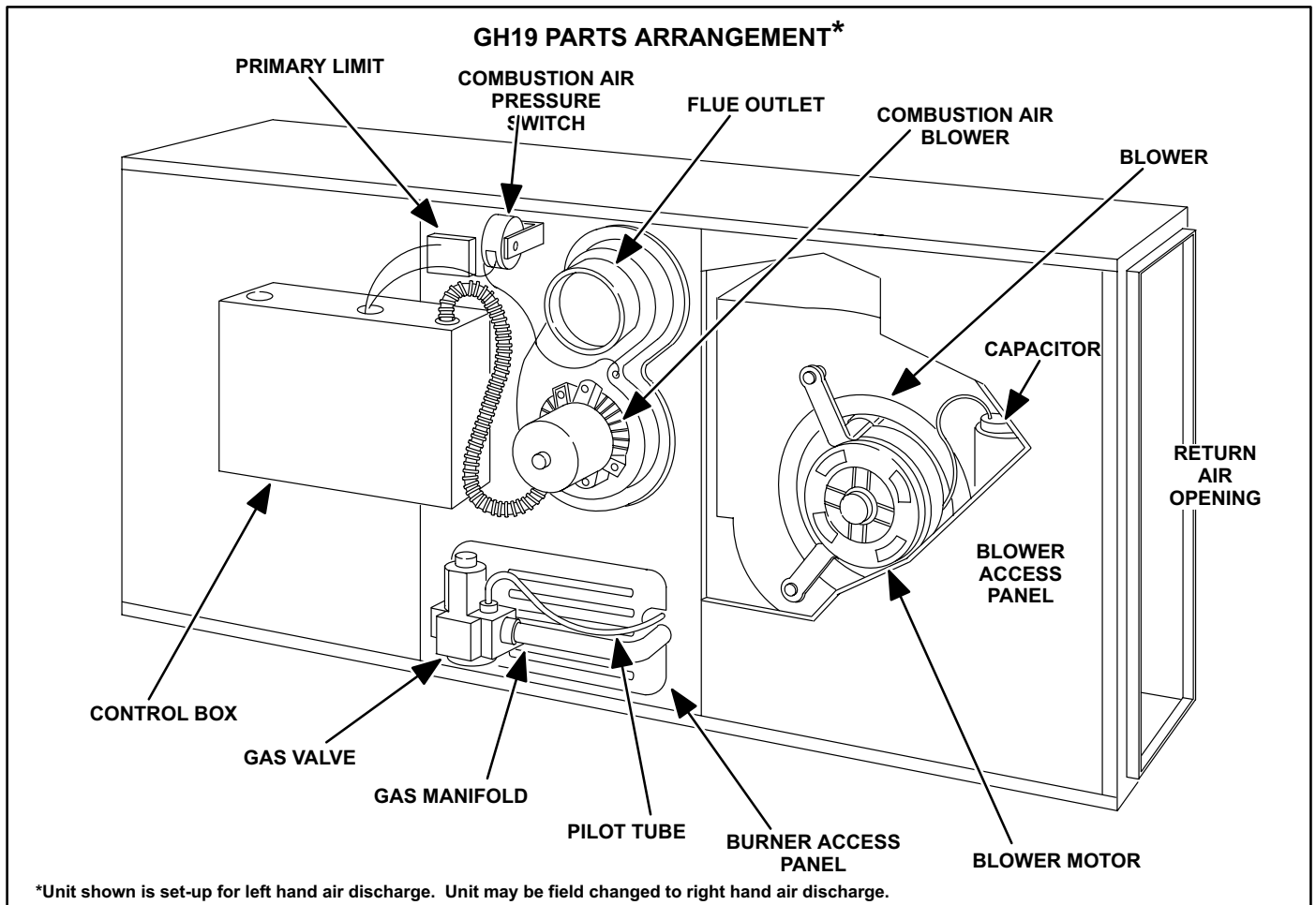

FIGURE 1

## I - UNIT COMPONENTS

GH19 unit components are shown in figure 1. The blower controls can be accessed by removing control box cover. The gas valve is located outside the cabinet just below the control box. Burners can be accessed by removing the burner access panel.

### A - Control Box Components

The GH19 control box is shown in figure 3. It is located on the side of the unit. The control box can be accessed by removing the screws on either side of the control box then removing the control box cover. The control box houses the (T1) transformer and most electrical controls. It serves as a make-up box for 24V thermostat and line voltage field wiring. It also contains a grounding lug for the unit.

#### 1 - Control Transformer (T1)

All GH19 series units use a single line voltage (120VAC) to

24VAC transformer. It is located inside the control box. Its purpose is to provide 24VAC power to the control voltage section of the unit. The transformer is rated 40VA.

#### 2 - Low Voltage Fuse (F1)

All units are equipped with a fuse located in series with the 24V output of the transformer. The fuse is rated 2-amp slow-blow type.

#### 3 - Blower Control (A15)

All GH19 units utilize a blower control (A15) as illustrated in figure 4. It is located in the unit control box. The blower control is a printed circuit board which controls the blower and monitors primary limit and gas valve operation. The control has a non-adjustable, factory preset "on" blower timing. The blower cycles on 30 seconds after the gas valve is energized.

Blower "off" timings are field adjustable by front-seating and back-seating a set of screws on the face of the circuit board. Figure 13 shows how to adjust the blower off timings.

### GH19 HEATING COMPONENTS

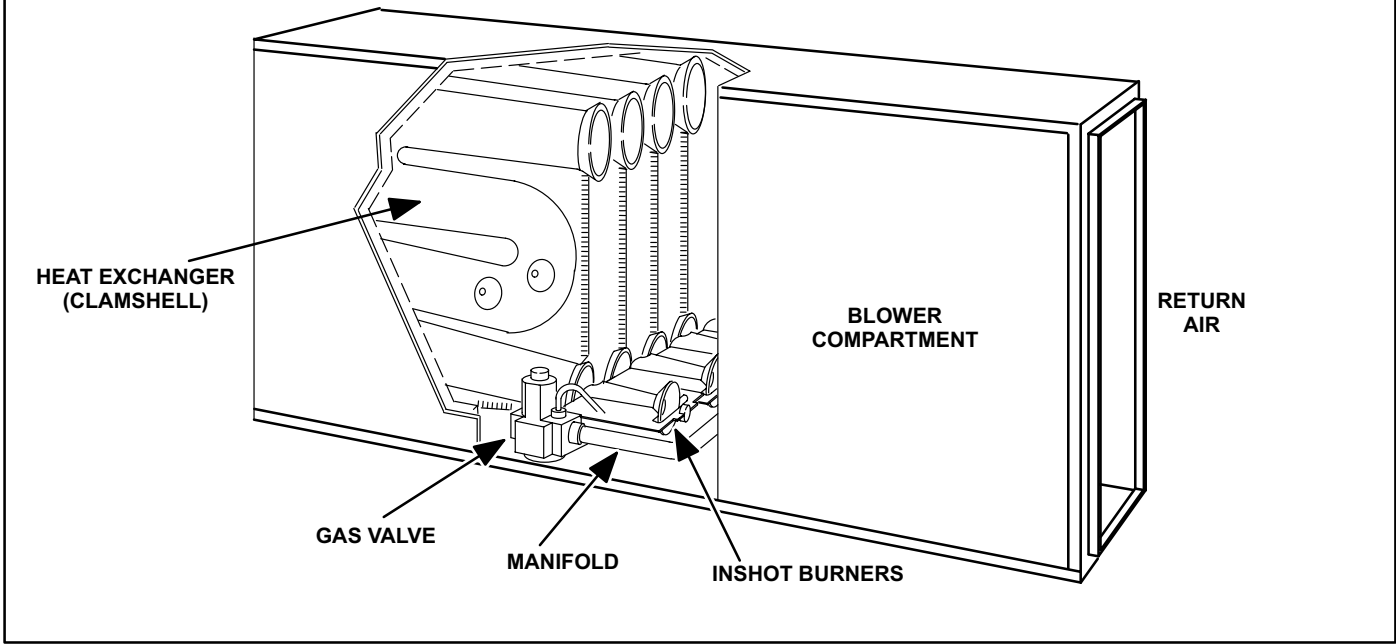

FIGURE 2

### GH19 CONTROL BOX

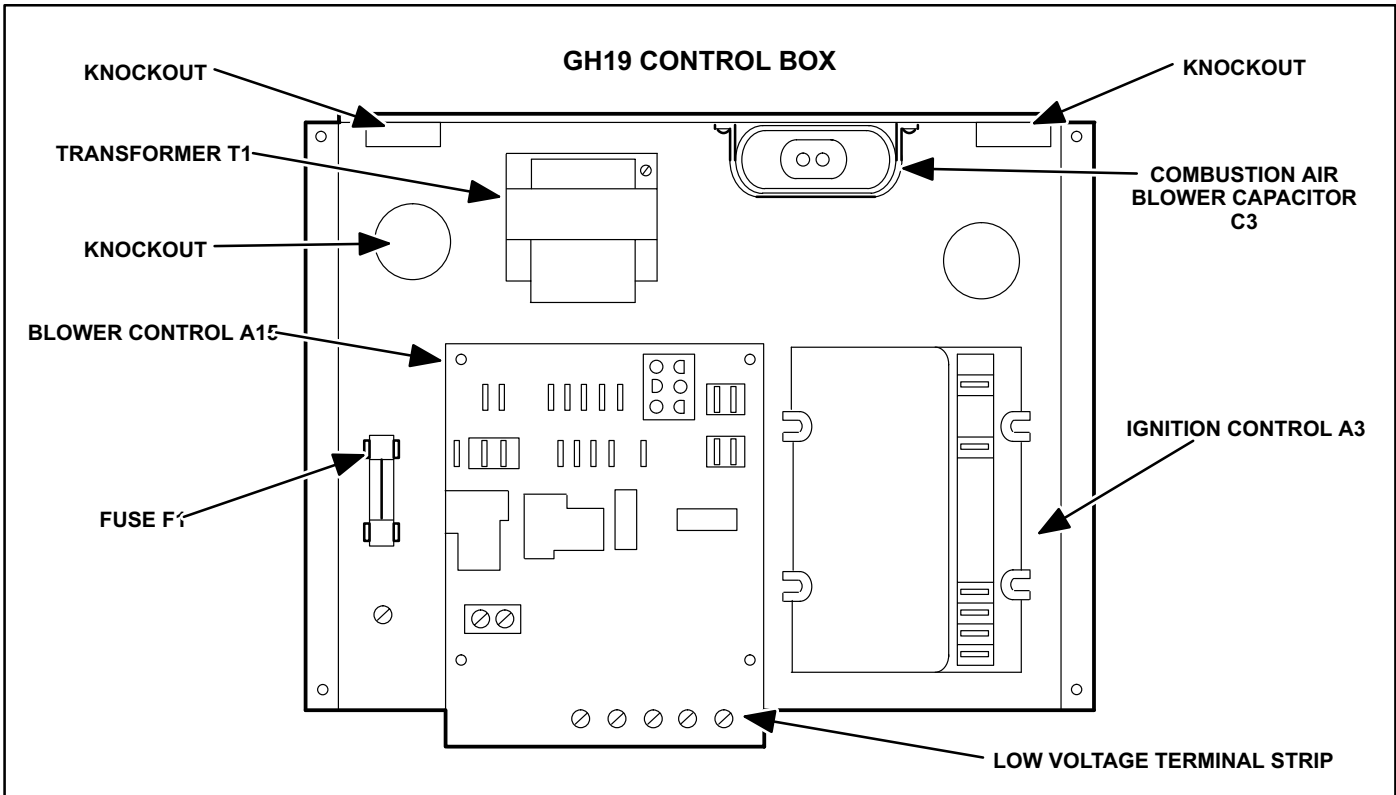
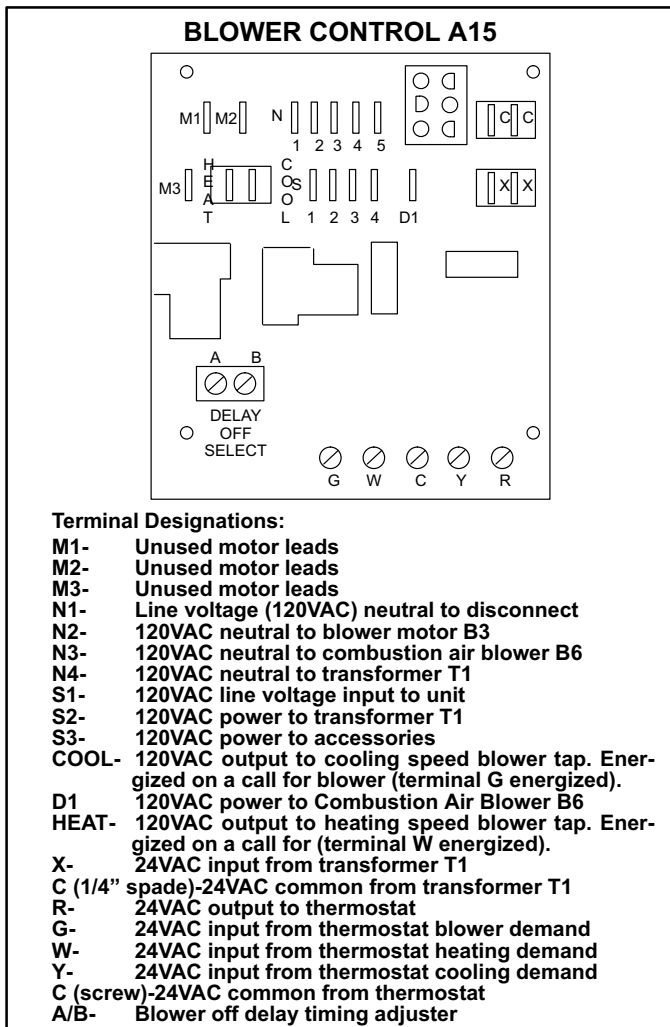

FIGURE 3



**FIGURE 4**

**How the Blower Control Works:**

On a call for heat (W) terminal D1 is immediately energized (by internal relay K13). At the same time, blower control A15 closes an internal relay (K3) which enables the supply air blower heating speed and disables the cooling speed. When the ignition control opens the main gas valve, the blower control senses that the gas valve is open and begins blower "ON" timing sequence (internal relay K36 is energized). At the end of the "ON" timing sequence, the blower control energizes the supply air blower.

When heating demand ends, the blower control senses that the main gas valve is closed (internal relay K36 de-energized) and begins blower "OFF" timing sequence.

If any of the safety limits open during unit operation, internal relay K36 is de-energized and the blower control initiates an "OFF" timing sequence.

**4 - Ignition Control (A3) (Figure 5)**

The Honeywell electronic ignition control (A3) is an intermittent ignition control module located in the control box. See figure 3. When there is a call for heat, the control generates a spark to ignite the pilot, after which the control senses the flame. If the flame current is too weak (less than 1 microamp) the control will shut down and de-energize the gas valve. Flame current should be between 1 and 5 microamps.

**⚠ DANGER**

**Shock hazard.**  
Spark related components contain high voltage. Disconnect power before servicing unit. The ignition control is not field repairable. Can cause unsafe operation, injury or death.

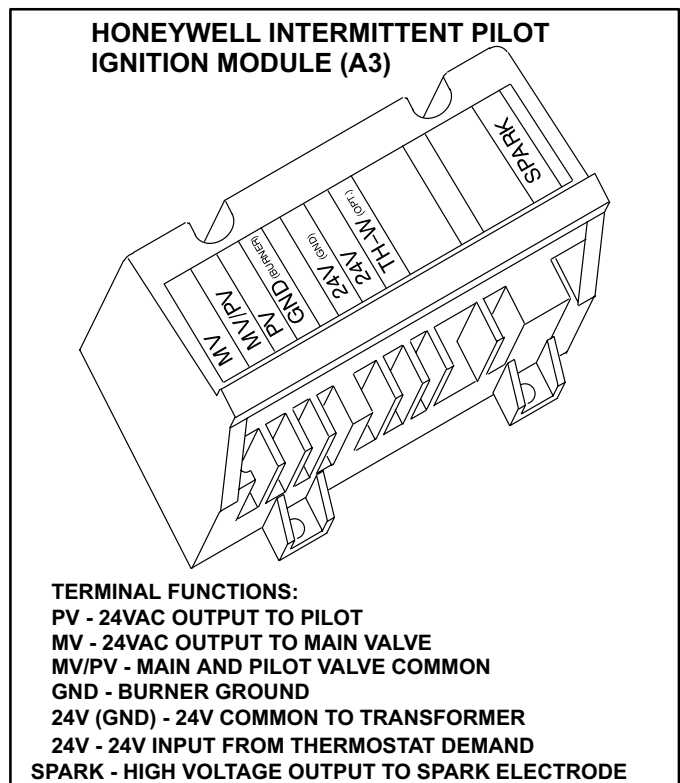

**FIGURE 5**

**How the Ignition Control Works:**

The ignition control receives a call for heat only after combustion air prove switch S18 closes. When the ignition control receives a call for heat, the control immediately opens the pilot valve and begins to spark. The ignition control allows the pilot valve to remain open as long as pilot flame is sensed. If pilot flame is not sensed, the control will lock out

after 15 seconds and must be manually reset. A timer in the control starts timing the moment a trial for ignition starts. Spark continues until flame is sensed or until 15 seconds has elapsed. If the control is trying for ignition when 15 seconds has elapsed, the control de-energizes the pilot valve. The control will remain locked out until reset. The control can be reset by setting the room thermostat below room temperature for one minute or by removing power to the unit for one minute.

When pilot flame is established, a flame rectification circuit is completed between the sensor and burner ground. The flame sensing circuit in the ignition control detects the flame current and resets the lockout timer. Also when flame is sensed, the control shuts off the spark and energizes the main gas valve operator. When a call for heat ends, both gas valve operators close immediately.

## B - Other Unit Components

### 1 - Blower Motors and Capacitors

All GH19 units use direct drive blower motors. All motors used are 120V permanent split capacitor (PSC) single-phase motors with two capacitor wires. All motors are equipped with sleeve bearings. See table1 for ratings.

TABLE

GH19 BLOWER RATINGS 120V 1PH		
BLOWER MOTOR	HP	CAP
Q3, Q3/4	1/3	7.5MFD 370V
Q4/5	1/2	15MFD 370V

### 2 - Door Interlock Switch (S51)

A single-pole single-throw door interlock switch is located behind the blower access panel. The switch is wired in series with line voltage to the control transformer. When the blower door access panel is removed the unit will shut down.

### 3 - Combustion Air Blower Motor and Capacitor

Combustion air blower B6 uses a single-phase PSC motor which uses a capacitor for efficiency. The combustion air blower is rated at 1/25 hp and is equipped with sleeve type bearings. The capacitor is rated 4 mfd at 370V.

### 4 - Combustion Air Prove Switch (S18)

GH19 series units are equipped with a combustion air prove switch mounted on the side of the unit just above the control box. The switch is connected to the combustion air blower housing by means of a flexible nylon hose. It monitors air pressure in the combustion air blower housing. The switch is a single-pole single-throw pressure switch electrically connected in series with the ignition control and gas valve.

On start-up, the switch senses that the combustion air blower is operating. It closes a circuit to the ignition control when pressure inside the combustion air blower housing increases above 0.65 in. w.c. The pressure sensed by the switch is relative to atmospheric pressure. If the flue becomes obstructed during operation, the switch senses a drop in pressure and opens the circuit to the ignition control and gas valve when pressure drops below 0.50 in. w.c.

The switch is factory set and is not field adjustable. It is a safety shut-down control in the furnace and must not be bypassed for any reason.

### 5 - Flame Rollout Switch (S47)

Flame rollout switch is a high temperature limit located on top of the burner assembly. The limit is a N.C. SPST manual-reset limit connected in series with ignition control A3. When S47 senses rollout, the ignition control immediately closes the gas valve. If unit is running and flame rollout is detected, the ignition control will be disabled until the control is manually reset. The switch is factory set to open at 300°F on a temperature rise and cannot be adjusted.

### 6 - Blocked Vent Shut-Off Switch (S62)

C.G.A. units are equipped with a blocked vent shut-off switch located on the outlet of the combustion air blower. The limit is a N.C. SPST manual-reset limit connected in series with ignition control A3. When S62 senses a blocked flue condition, the ignition control immediately closes the gas valve. If unit is running and a blocked flue is detected, the ignition control will be disabled until the control is manually reset. The switch is factory set to open at 300°F on a temperature rise and cannot be adjusted.

### 7 - Primary Limit Control (S10)

The primary limit switch (S10) on all units is located in the unit just above the unit control box. All units use a SPST self resetting limit. See figure 6. When excess heat is sensed in the heat exchanger, the limit switch will open and interrupt the current to the gas valve. If the limit is tripped, the blower control energizes the blower. The limit automatically resets when unit temperature drops below the reset point. See table 2.

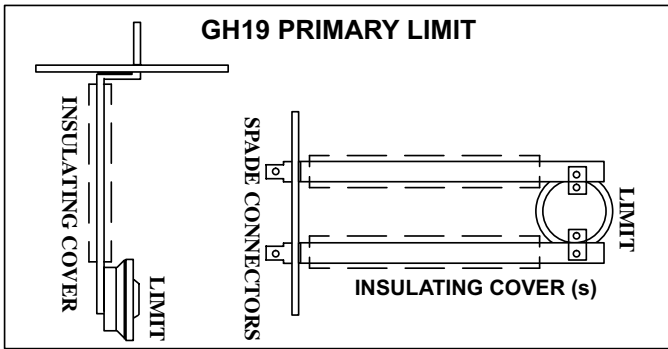

FIGURE 6

TABLE 2

PRIMARY LIMIT TEMPERATURES

UNIT MODEL NO.	TEMP. RISE	TEMP. FALL
GH19Q3-50	190°F ± 5°F	150°F ± 8°F
GH19Q3-75	170°F ± 5°F	130°F ± 8°F
GH19Q3/4-100	140°F ± 5°F	100°F ± 8°F
GH19Q4/5-125	140°F ± 5°F	100°F ± 8°F

## 8 - Gas Valve (Figure 7)

All GH19 units use a Honeywell gas valve. All gas valves are internally redundant to assure safety shut-off. If the gas valve must be replaced, the same type valve must be used.

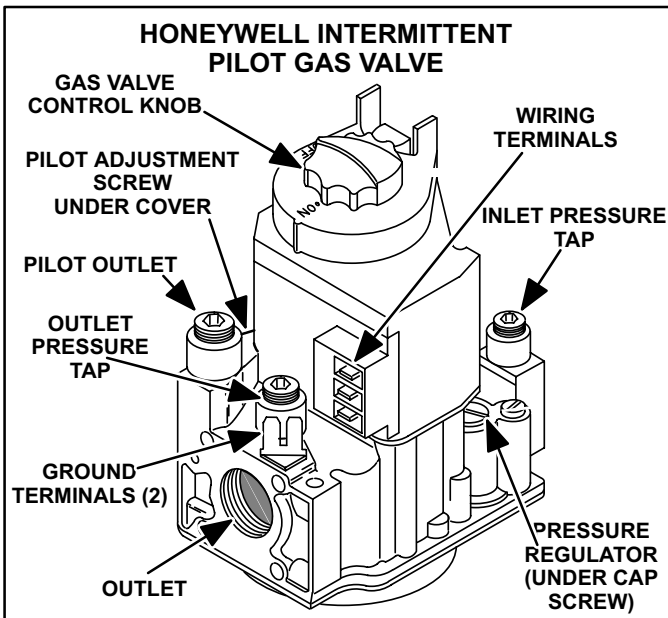

FIGURE 7

The gas knob is located on top of the control. 24VAC terminals are located on the side of the valve. All terminals on the gas valve are connected to wires from the electronic ignition control. The wire marked "PV" energizes the pilot valve when it receives 24VAC from the ignition control. The wire marked "M" energizes the main valve when it receives

24VAC power from the ignition control. The wire marked "P/M" provides 24VAC common to both the pilot and main valves. A fourth wire marked "GND" grounds the gas valve to the cabinet.

## 9 - Pilot Tube, Spark Electrode and Flame Sensor

The pilot tube from the gas valve and the flame sensor and ignition wires from the electronic ignition control attach to the pilot burner assembly.

Figure 8 shows the appearance of the flame envelope.

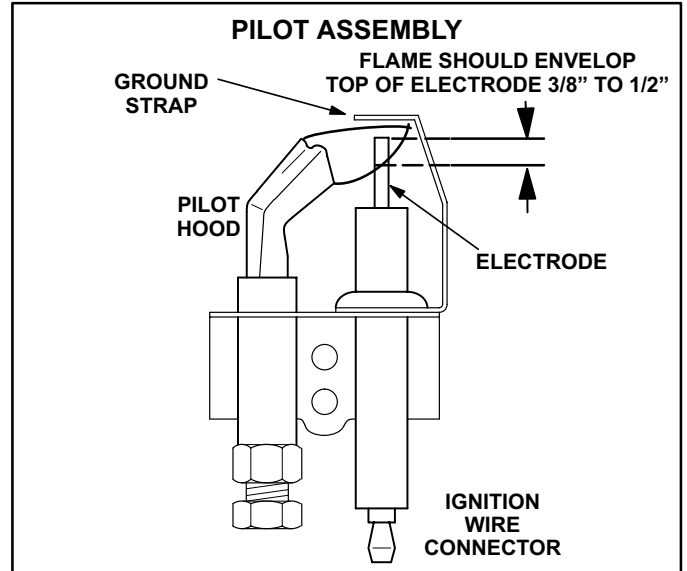

FIGURE 8

## II - PLACEMENT AND INSTALLATION

Make sure the unit is installed in accordance with installation instructions and all applicable codes.

## III - START-UP

### A - Preliminary and Seasonal Checks

- 1 - Inspect electrical wiring, both field and factory installed for loose connections. Tighten as required.
- 2 - Check voltage at disconnect switch. Voltage must be within range listed on the nameplate. If not, consult the power company and have voltage condition corrected before starting unit.

### B - Heating Start-Up

## ⚠ WARNING

**Shock and burn hazard.**  
GH19 units are equipped with an intermittent pilot ignition system. Do not attempt to light manually.

- 1 - Set thermostat to OFF position. Close manual knob on gas valve.

- 2 - Wait 5 minutes.
- 3 - Open manual knob on gas valve, replace burner access door and turn on unit electrical supply.
- 4 - Set fan switch to AUTO or ON and move system selection switch to HEAT. Adjust thermostat to a setting above room temperature.
- 5 - If unit does not light the first time, it will attempt one more ignition before locking out.
- 6 - If lockout occurs, repeat steps 1, 2, 3 and 4.

### C - Safety or Emergency Shutdown

Turn off power to unit. Close manual and/or main gas valves.

### D - Extended Period Shutdown

Turn off thermostat or set to "UNOCCUPIED" mode. Close all gas valves (both internal and external to unit) to guarantee no gas leak into combustion chamber. Turn off power to unit. All access panels, covers and vent caps must be in place and secured.

## IV - HEATING SYSTEM SERVICE CHECKS

### A - A.G.A. Applications and Requirements

All units are A.G.A. design certified without modifications. Refer to the GH19 Operation and Installation Instruction Manual Information.

### B - Gas Piping

Gas supply piping should not allow more than 0.5"W.C. drop in pressure between gas meter and unit. Supply gas pipe must not be smaller than unit gas connection.

Compounds used on gas piping threaded joints should be resistant to action of liquefied petroleum gases.

### C - Testing Gas Piping

#### **⚠ IMPORTANT**

**In case emergency shutdown is required, turn off the main shut-off valve and disconnect the main power to unit. These controls should be properly labeled by the installer.**

When pressure testing gas lines, the gas valve must be disconnected and isolated. Gas valves can be damaged if subjected to more than 0.5 psig (14" W.C.). See figure 9. If the pressure is equal to or less than 0.5 psig (14"W.C.), use the manual shut-off valve before pressure testing to isolate furnace from gas supply.

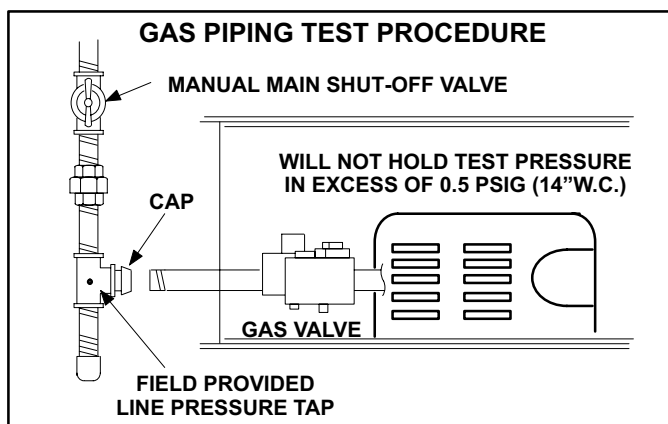

**FIGURE 9**

When checking piping connections for gas leaks, use preferred means. Kitchen detergents can cause harmful corrosion on various metals used in gas piping. Use of a specialty Gas Leak Detector is strongly recommended. It is available through Lennox under part number 31B2001. See Corp. 8411-L10, for further details.

Do not use matches, candles, flame or any other source of ignition to check for gas leaks.

### D - Testing Gas Supply Pressure

When testing supply gas pressure, connect test gauge to inlet pressure tap (field provided). See figure 9. Test supply gas pressure. Low pressure may result in erratic operation or underfire. High pressure can result in permanent damage to gas valve or overfire. For natural gas units, operating pressure at unit gas connection must be between 4.5" W.C. and 10.5" W.C. For L.P. gas units, operating pressure at unit gas connection must be between 10.5" W.C. and 13.5" W.C.

On multiple unit installations, each unit should be checked separately, with and without units operating. Supply pressure must fall within range listed in previous paragraph.

### E - Check Manifold Pressure

After line pressure has been checked and adjusted, check manifold pressure. Move pressure gauge to outlet pressure tap located on unit gas valve (GV1). See figure 7 for location of pressure tap on gas valve.

#### **⚠ IMPORTANT**

**For safety, connect a shut-off valve between the manometer and the gas tap to permit shut off of gas pressure to the manometer.**

The gas valve is factory set and should not require adjustment. All gas valves are factory regulated. See table 3 .

**TABLE 3**

<b>GAS VALVE REGULATION</b>	
<b>Unit (Fuel)</b>	<b>Operating Pressure (outlet) in. W.C.</b>
<b>Natural</b>	3.5 +0 -0.3 (adjustable range 3-5)
<b>L.P.</b>	9.5 ± 0.5 (adjustable range 8-12)

**Manifold Adjustment Procedure:**

- 1 - Connect a test gauge to outlet pressure tap on gas valve. Start unit and allow 5 minutes for unit to reach high fire steady state.
- 2 - While waiting for the unit to stabilize, notice the flame. Flame should be stable and should not lift from burner. Natural gas should burn blue. L.P. gas should burn mostly blue with some orange streaks.
- 3 - After allowing unit to stabilize for 5 minutes, record manifold pressure and compare to values given in table 3.

*NOTE- Disconnect heating demand as soon as an accurate reading has been obtained.*

**F - Proper Gas Flow**

To check for proper gas flow to combustion chamber, determine Btuh input from unit rating plate or table or the specifications tables on pages 1 and 2. Divide input rating by Btuh per cubic foot of available gas. Result is the number of cubic feet per hour required. Determine flow of gas through gas meter for two minutes. Multiply by 30 to get hourly flow of gas to burner.

*NOTE- To obtain accurate reading, shut off all other gas appliances connected to meter.*

**G - High Altitude Derate**

Check for local or state codes which might have priority over these instructions. Check the local gas supplier to find out if gas supply has already been derated. If the gas supply has already been derated, modifications to the unit are not necessary.

**The 4% rule:**

If the gas supply is not already derated, both L.P. and natural gas units require a 4% reduction in the input rate for every 1000 ft. above sea level. For example, an installation at 5000 ft above sea level would require a 20% derate. If local codes require that the orifices be changed, orifice blanks can be drilled using a 4% smaller drill for every 1000ft. above sea level.

*NOTE-This is the only permissible field derate for this appliance.*

**⚠ WARNING**

**Never hand drill orifice blanks. Hand drilling can lead to over-firing, improper combustion, flashback or flame rollout. Hand drilling can result in fire or personal injury.**

**⚠ IMPORTANT**

**For safety, shut unit off and remove manometer as soon as an accurate reading has been obtained. Take care to replace pressure tap plug.**

**H - Flame Signal**

Flame signal or microamp is an electrical current which passes from the ignition control through the sensor electrode during unit operation. Current passes from the sensor through the flame to ground to complete a safety circuit. A 50 microamp DC meter is needed to check flame signal on the primary ignition control.

**⚠ WARNING**

**Electrical shock hazard.. These instructions MUST be followed exactly. Disconnect power before making wiring connections. Flame current must be measured with power on. Use care to avoid contact with ignition spark circuit.**

**To Measure Flame Signal:**

- 1 - Adjust room thermostat below room temperature. Disconnect power to unit.
- 2 - Connect meter, switch and resistor in circuit as shown in figure 10. Set meter to 0.25 mA scale.

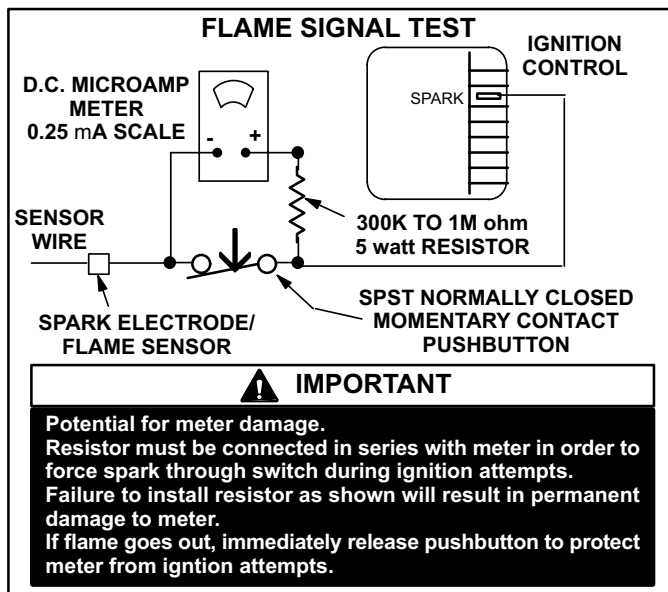

**FIGURE 10**

- 3 - Protect or insulate bare wire to prevent accidental grounding or personal contact during ignition attempts.
- 4 - Disconnect (MV) terminal at ignition control.
- 5 - Reconnect power and adjust thermostat above room temperature. Only pilot burner will light.





- After pilot lights, press pushbutton and read flame current on meter. If flame current is not steady, read lowest observed value. Flame current should measure at least 1.5 mA during operation.

Flame signal may rise above 1.5 to 5 microamps for the first few seconds after ignition and then level off.

### I - Adjusting Pilot Flame

Pilot flame may be adjusted as needed to improve flame signal or ignition characteristics. The top 3/8" to 1/2" of the flame electrode (figure 8) should be enveloped in flame.

#### To Adjust Pilot Flame:

- Remove pilot adjustment screw cover. See figure 7.
- Turn inner adjustment screw clockwise  to decrease or counterclockwise  to increase flame.
- Always replace cover screw after adjustment. Tighten firmly to prevent gas leakage.

### V - BLOWER OPERATION/ADJUSTMENT

*NOTE- The following is a generalized procedure and does not apply to all thermostat controls.*

- Blower operation is dependent on thermostat control system.
- Generally, blower operation is set at thermostat sub-base fan switch. With fan switch in ON position, blower operates continuously. With fan switch in AUTO position, blower cycles with demand or runs continuously while heating or cooling circuit cycles.
- In all cases, blower and entire unit will be off when the system switch is in OFF position.

### A - Temperature Rise

Temperature rise for GH19 units depends on unit output, blower speed and static pressure of the unit setup. Blower speed must be set for unit operation within range of "AIR TEMP. RISE ° F" listed on the unit rating plate.

#### To Measure Temperature Rise:

- Place plenum thermometers in the supply and return air plenums. Locate thermometers in the first horizontal run of the warm air plenum where it will not pick up radiant heat from the heat exchanger.
- Set thermostat to highest setting.
- After plenum thermometers have reached their highest and steadiest readings, subtract the two readings. The difference should be in the range listed on the unit rating plate. If the temperature is too low, decrease blower speed. If temperature is too high, first check the firing rate. Provided the firing rate is acceptable, increase blower speed to reduce temperature. To change blower speed taps see the Blower Speed Taps section in this manual.

### B - External Static Pressure

Units must be ducted and cannot be used as unit heater.

- Measure tap locations as shown in figure 11.
- Punch a 1/4" diameter hole in supply and return air plenums. Insert manometer hose flush with inside edge of hole or insulation. Seal around the hose with permagum. Connect the zero end of the manometer to the discharge (supply) side of the system. On ducted systems, connect the other end of manometer to the return duct as above. For systems with non-ducted returns, leave the other end of the manometer open to the atmosphere.

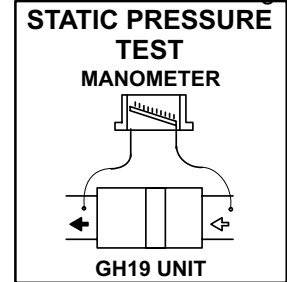

**FIGURE 11**

- With only the blower motor running and the evaporator coil dry, observe the manometer reading. Adjust blower motor speed to deliver the required amount of air.
- External static pressure drop must not be more than 0.5" W.C.
- Seal the hole when the check is complete.

### C - Blower Speed Taps

Blower speed tap selection is accomplished by changing the taps at the blower motor. Blower speed selections are listed in table 4.

#### To Change Blower Speed:

- Turn off electric power to furnace.
- Remove blower access panel.
- Select desired speeds for heating and cooling. (Red = heating, Black = cooling, White = common). See table 4.

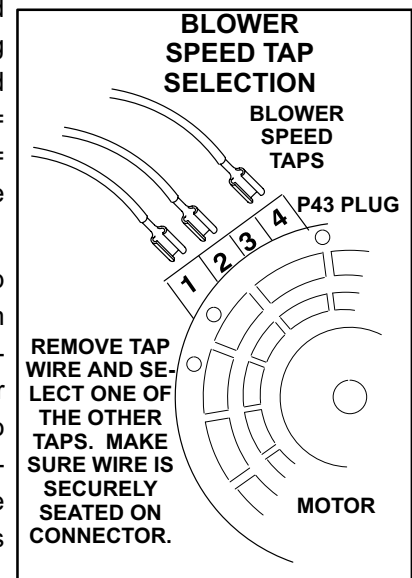

**FIGURE 12**

- Remove wire tap connector from motor. Select connector location for new speed (refer to unit wiring diagram). Insert wire terminal until it is securely in place. See figure 12.

**TABLE 4**

<b>BLOWER SPEED SELECTION</b>			
<b>UNIT</b>	<b>Factory Connected Speed Taps</b>		<b>Motor Speeds Available</b>
	<b>Cool</b>	<b>Heat</b>	
GH19Q3-50	2	4	3
GH19Q3-75	2	4	3
GH19Q3/4-100	2	4	3
GH19Q4/5-125	2	4	3

**D - Blower Timings**

Blower “off” timings (time that the blower operates after the heat demand has been satisfied) are determined by the position of screws on the blower control board. See figure 13. To adjust blower “off” timings, front-seat or back-seat the screws corresponding with timings shown in figure 13. Blower “off” time will affect comfort and efficiency and is adjustable to satisfy individual applications. Blower “on” time is factory set at 30 seconds and is not adjustable.

**⚠ WARNING**

**Shock hazard.**  
**Make sure to disconnect power before changing fan “OFF” timings.**  
**Can cause personal injury.**

**⚠ IMPORTANT**

**Potential for improper operation.**  
**If blower “OFF” timing is set too low, residual heat in heat exchanger may cause primary limit S10 to trip resulting in frequent cycling of blower. If this occurs, adjust blower to longer time setting.**

**BLOWER TIMING ADJUSTMENT SCREWS**

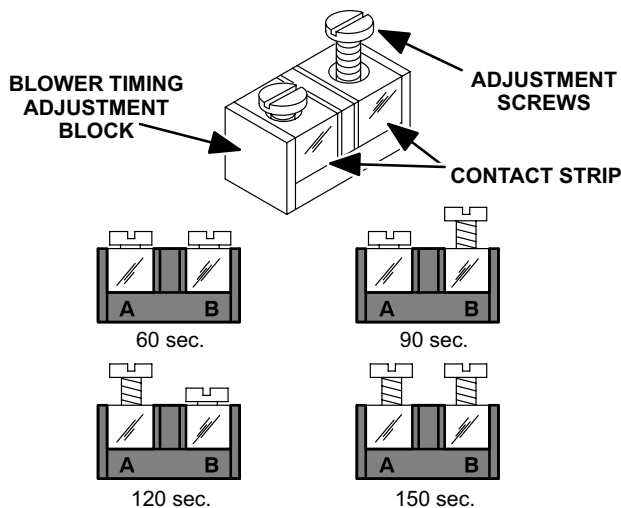

**FIGURE 13**

**VI - MAINTENANCE**

Some GH19 maintenance procedures require disconnecting wires from electrical components.

**⚠ DANGER**

**Fire and shock hazards.**

**Failure to heed this warning will lead to improper wiring or plumbing and can result in improper operation, component failure, fire or electrical shock.**

**The procedure in the following paragraph must be followed exactly if any electrical or gas plumbing disassembly is required for maintenance or service.**

Before performing any service or maintenance procedure which requires disconnecting the gas plumbing or any electrical wiring, make sure to carefully mark all connections before disconnecting the component. For example, figure 14 shows the gas valve wires being marked according to the terminals the wires are connected to. Figure 15 shows the gas valve being marked for direction of gas flow. Refer closely to the wiring diagram during reassembly. Double-check all connections when finished.

**MARKING WIRES BEFORE DISCONNECTING**

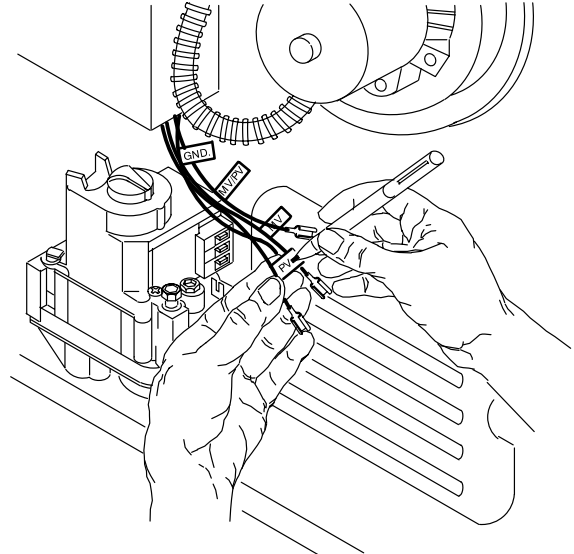

**⚠ DANGER**

**Shock, fire and explosion hazards.**  
**Before performing any service, maintenance or change-over procedure, carefully identify and mark all wires to be disconnected. If the gas valve is to be disconnected, be sure to mark direction of gas flow through the valve.**  
**Failure to follow this procedure exactly can lead to improper or erratic operation, electrical shock, fire or explosion resulting in personal injury or death.**

**FIGURE 14**

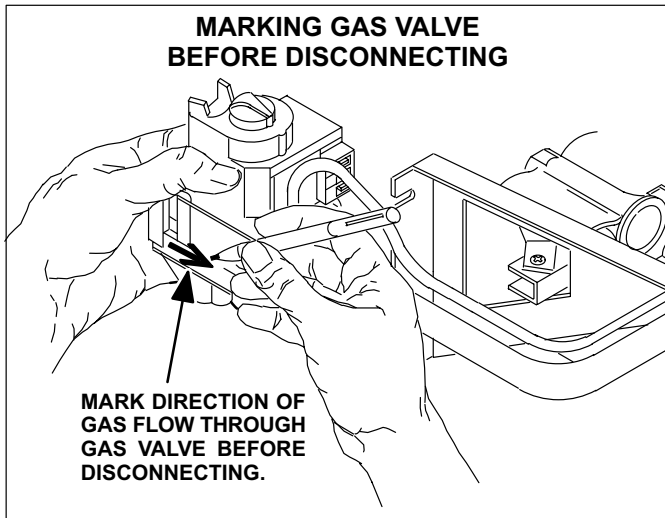

FIGURE 15

At the beginning of each heating season, the system should be checked as follows:

### A - Filters

GH19 units should be equipped with optional field installed filters.

#### To Inspect/Clean Filters:

- 1 - Turn off electric power to furnace.
- 2 - Remove the filter from the filter frame.
- 3 - Wash filters with warm water and mild detergent. When dry, filters should be sprayed with filter handicoater before replacing. Filter Handicoater is RP products coating no. 418 and is available as Lennox part no. P-8-5069.
- 4 - Re-install filters when dry.

### B - Supply Air Blower

- 1 - Check and clean blower wheel.
- 2 - Motors used on GH19 series units are permanently lubricated and need no further lubrication.

### C - Flue and Chimney

Flue must conform to all AGA/GAMA venting requirements for "Category I Central Furnaces." Flue pipe deteriorates from the inside out and must be disconnected in order to check thoroughly. Check flue pipe, chimney and all connections for tightness and to make sure there is no blockage or leaks.

### D - Cleaning Heat Exchanger and Burners

*NOTE-Use papers or protective covering in front of furnace while cleaning furnace.*

The heat exchanger, manifold, burner and gas valve assembly is shown in figure 16.

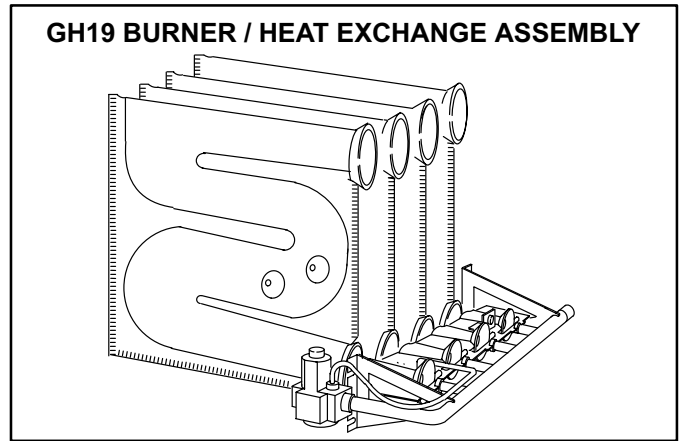

FIGURE 16

#### To clean heat exchanger:

- 1 - Turn off both electrical and gas power supplies to furnace. Refer to figures 1 and 2 during disassembly and reassembly procedures.
- 2 - Mark wires as shown in figure 14 and mark direction of gas flow as shown in figure 15.
- 3 - Remove manifold retention plate (figure 17).
- 4 - Slide burner assembly out of unit (figure 18).
- 5 - Remove control box from unit, leaving wires connected to control box components.
- 6 - Remove differential pressure switch and combustion air blower (figure 19).
- 7 - Remove combustion air blower mullion.
- 8 - Remove flue-return and flue-box from heat exchanger (figure 20).

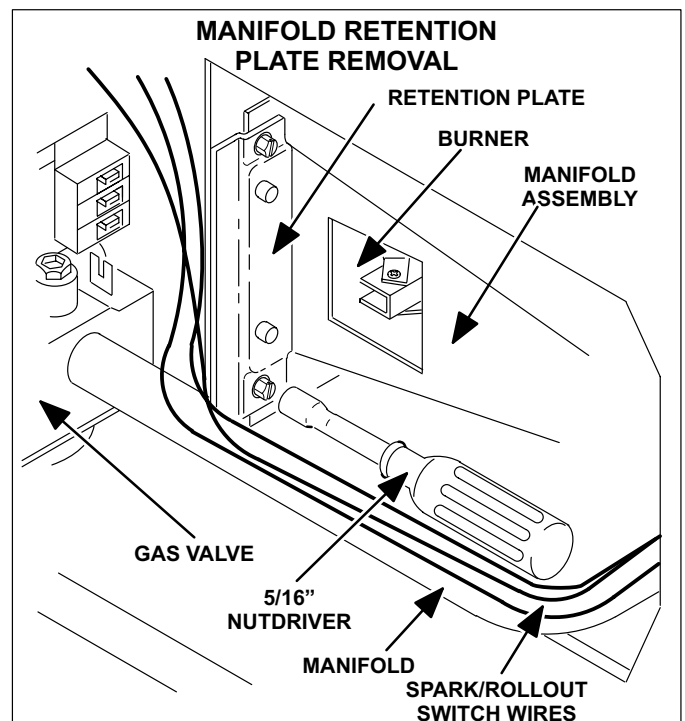
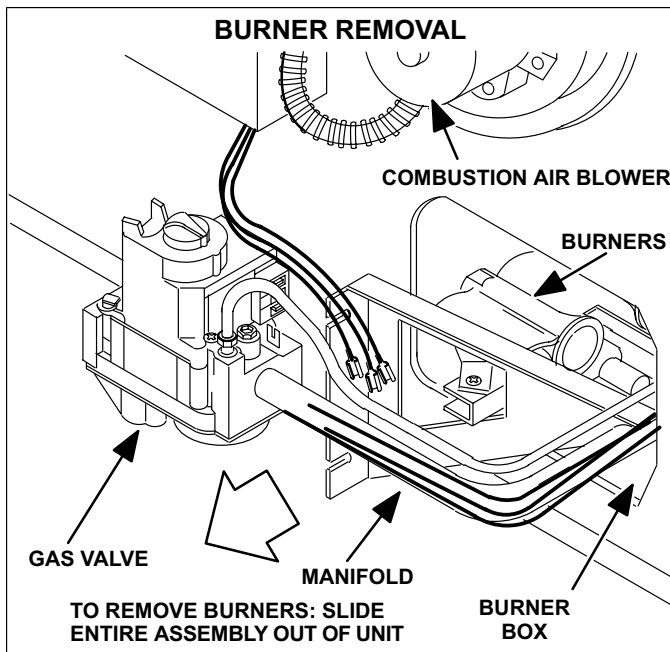

FIGURE 17

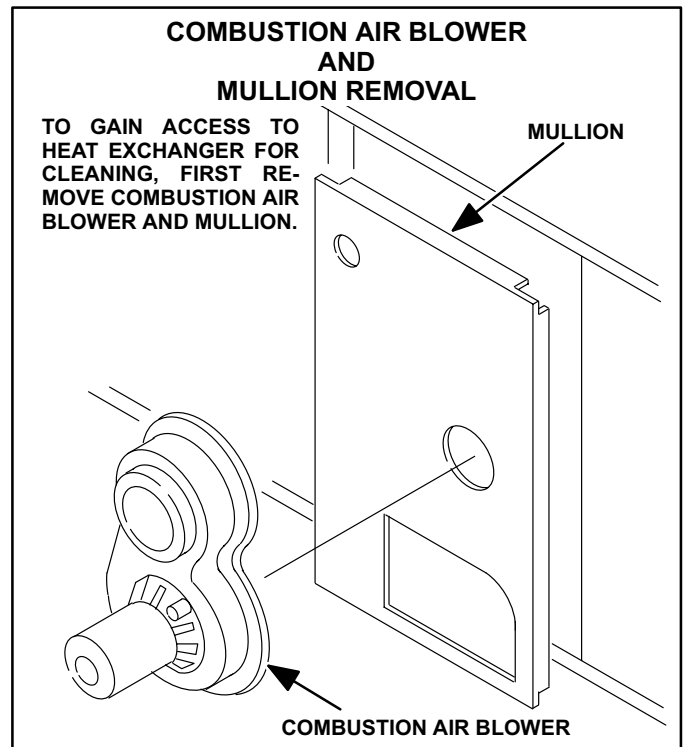

**FIGURE 18**

- 9 - Place the burner / manifold assembly on a flat work surface. Vacuum the burner ports (it may be necessary to first use a soft-bristle brush to remove dirt).
- 10 - Check pilot location and spark electrode / flame sensor gap.
- 11 - Vacuum each heat exchanger clamshell.
- 12 - Using a small rubber mallet, gently tap each tube to break loose soot and scale deposits within the tubes. Be careful not to damage the heat exchanger.
- 13 - Vacuum each heat exchanger clamshell.
- 14 - Using a straight attachment on the vacuum in the burner opening, vacuum the length of each heat exchanger tube. Vacuum the burner box.
- 15 - Re-install all components when finished. Carefully check all piping connections (factory and field) for gas leaks. Use a leak detecting solution or other preferred means. Carefully check all wiring against the factory wiring diagram. Make sure all electrical connections are tight and make sure wires are routed away from sharp edges and heat sources.
- 16 - Turn on gas and electrical supply.

**⚠ CAUTION**

Potential for gas leaks, fire or explosion. Some soaps used for leak detection are corrosive to certain metals. Carefully clean piping thoroughly after leak detection has been completed. Can cause damage to piping resulting in gas leaks, fire or explosion.



**FIGURE 19**

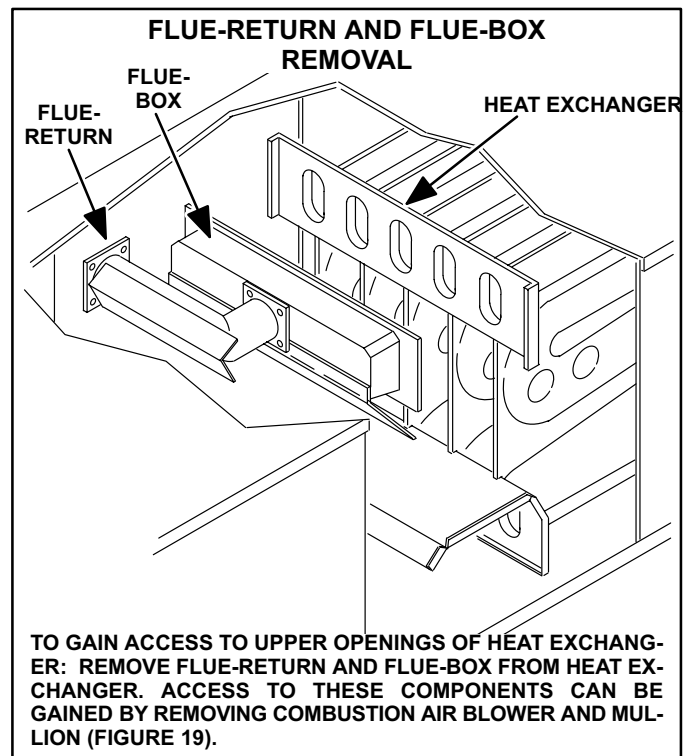

**FIGURE 20**

**E - Electrical**

- 1 - Check all wiring for loose connections.
- 2 - Check for correct voltage.
- 3 - Check amp-draw on blower motor.

KEY	DESCRIPTION
	COMPONENT
A3	CONTROL, BURNER, IGNITION
A15	CONTROL, BLOWER
B3	MOTOR, BLOWER
B6	MOTOR-COMB. AIR BLOWER
C3	CAPACITOR, COMB. AIR BLO.
C4	CAPACITOR, BLOWER MOTOR
F1	FUSE-TRANSFORMER
GVI	VALVE, GAS
J20	JACK, GAS
K3, -1	RELAY, BLOWER
K13, -1	RELAY, COMBUSTION AIR
K36, -1	RELAY, HEAT BLOWER
K43, -1	RELAY, ECONOMIZER HEAT
K107-1, 2, 3	RELAY, CONTINUOUS BLOWER
K109, -1	RELAY, ACCESSORY
P20	PLUG, GAS
P43	PLUG, BLOWER MOTOR
S1	THERMOSTAT, ROOM
S10	LIMIT, PRIMARY, GAS
S18	SWITCH-COMB. AIR PROVE
S47	SWITCH, FLAME, ROLL-OUT
S51	SWITCH, DOOR INTERLOCK
S62	SWITCH, BLOCKED VENT SHUT-OFF
S68, -1, 2	SWITCH, CONTINUOUS BLOWER
T1	TRANSFORMER-CONTROL

⚠ TO CHANGE MOTOR SPEED TAP AND FOR BLOWER SPEED SELECTION PROCEDURE, REFER TO INSTALLATION INSTRUCTION

⚠ FOR 50, 75 MBh UNITS NO WIRE ON TERMINAL (3).

⚠ FOR 100, 125 MBh UNITS NO WIRE ON TERMINAL (4)

IMPORTANT-TO PREVENT MOTOR BURNOUT, NEVER CONNECT MORE THAN ONE MOTOR LEAD TO ANY ONE CONNECTION.

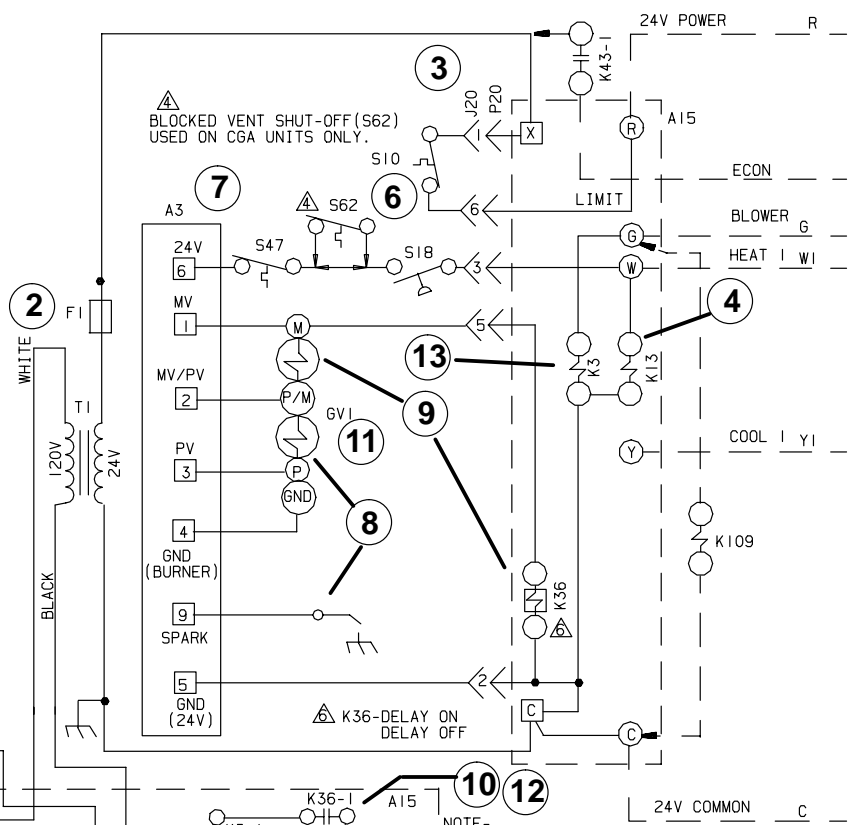

PLACE THERMOSTAT/CONTROL DIAGRAM HERE.

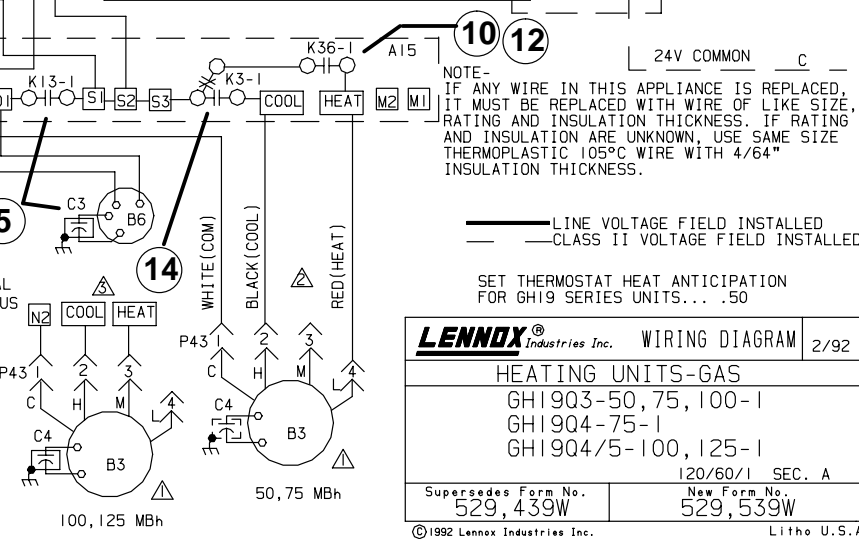
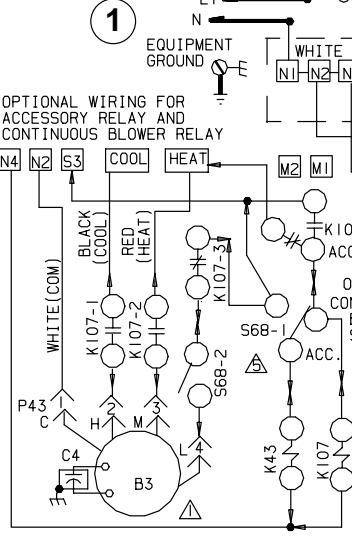

NOTE- IF ANY WIRE IN THIS APPLIANCE IS REPLACED, IT MUST BE REPLACED WITH WIRE OF LIKE SIZE, RATING AND INSULATION THICKNESS. IF RATING AND INSULATION ARE UNKNOWN, USE SAME SIZE THERMOPLASTIC 105°C WIRE WITH 4/64" INSULATION THICKNESS.

— LINE VOLTAGE FIELD INSTALLED  
 - - CLASS II VOLTAGE FIELD INSTALLED

SET THERMOSTAT HEAT ANTICIPATION FOR GH19 SERIES UNITS... .50

<b>LENNOX</b> Industries Inc. WIRING DIAGRAM		2/92
HEATING UNITS-GAS		
GH19Q3-50, 75, 100-1		
GH19Q4-75-1		
GH19Q4/5-100, 125-1		
Supersedes Form No. 529, 439W		120/60/1 SEC. A
New Form No. 529, 539W		
©1992 Lennox Industries Inc.		Litho U.S.A.

**SEQUENCE OF OPERATION**

- When disconnect is closed, 120V feeds to line voltage side of the blower control (A15). Door interlock switch (S51) must be closed for A15 to receive voltage.
- A15 supplies 120V to transformer (T1).
- T1 supplies 24VAC to terminal "X" on A15. In turn, terminal "R" of A15 supplies 24VAC to terminal "R" of the indoor thermostat.
- When there is a call for heat, W1 of the thermostat energizes W of the blower control with 24VAC. 24VAC applied to A15 terminal W energizes internal combustion air blower relay K13. Contacts K13-1 close immediately.
- When K13-1 closes, combustion air blower B6 is energized. Combustion air blower begins operating immediately.
- When combustion air blower B6 approaches full speed, combustion air prove switch S18 closes.
- When S18 closes, ignition control terminal 24V is energized.
- The spark electrode is immediately energized and the pilot valve is opened. If the pilot does not ignite, the control will lock out within 90 seconds.
- When flame current is sensed, the spark electrode is de-energized and the main operator of the gas valve and blower delay relay K36 (inside blower control A15) are energized. The ignition control monitors pilot flame current during burner operation. K36 delays 30 seconds before closing.
- When K36-1 closes, blower motor B3 is energized on heating speed.
- When heating demand is satisfied, the gas valve and ignition control are both immediately de-energized. Blower delay relay K36 (inside the blower control) begins a timing sequence before opening. Blower "OFF" timings are field adjustable on the face of the blower control. Refer to unit information manual.
- When K36-1 opens, blower B3 is de-energized.
- On a call for cooling or a call for blower, terminal G on blower control A15 is energized. Blower relay K3 (inside A15) is immediately energized.
- When K3-1 closes, blower B3 is immediately energized on cooling speed.

# GH19 SERIES UNITS

## BLOWER CONTROL A15 TROUBLESHOOTING FLOWCHART

