

GHR26 SERIES UNITS

GHR26 series units are high-efficiency horizontal or down flow gas furnaces manufactured with Lennox DuralokPlus™ aluminized and stainless steel clamshell-type heat exchangers. GHR26 units are available in heating input capacities of 50,000 to 120,000 Btuh (14.7 to 35.2 kW) and cooling applications from 2 through 5 tons (7.0 through 17.6 kW). Refer to Engineering Handbook for proper sizing.

Units are factory equipped for use with natural gas. A kit is available for conversion to LPG operation. GHR26-1 models use electronic (direct spark) ignition. GHR26-2 through -8 models are equipped with the Lennox Surelight silicon nitride ignition system. Each GHR26 unit meets the California Nitrogen Oxides (NO_x) Standards and California Seasonal Efficiency requirements. The gas valve is redundant to assure safety shut-off as required by A.G.A. and C.G.A.

The heat exchanger, burners and manifold assembly can be removed for inspection and service. The maintenance section gives a detailed description on how this is done.

Information contained in this manual is intended for use by qualified service technicians only. All specifications are subject to change. Procedures outlined in this manual are presented as a recommendation only and do not supersede or replace local or state codes.

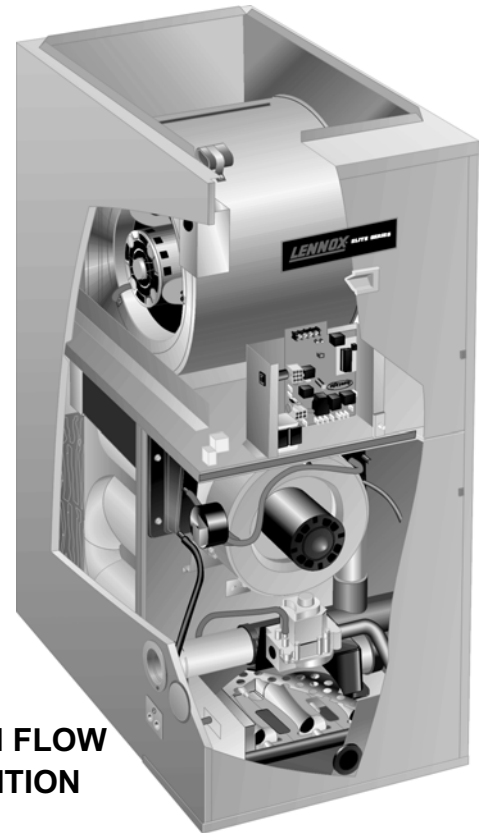

**DOWN FLOW
POSITION**

**HORIZONTAL
POSITION**

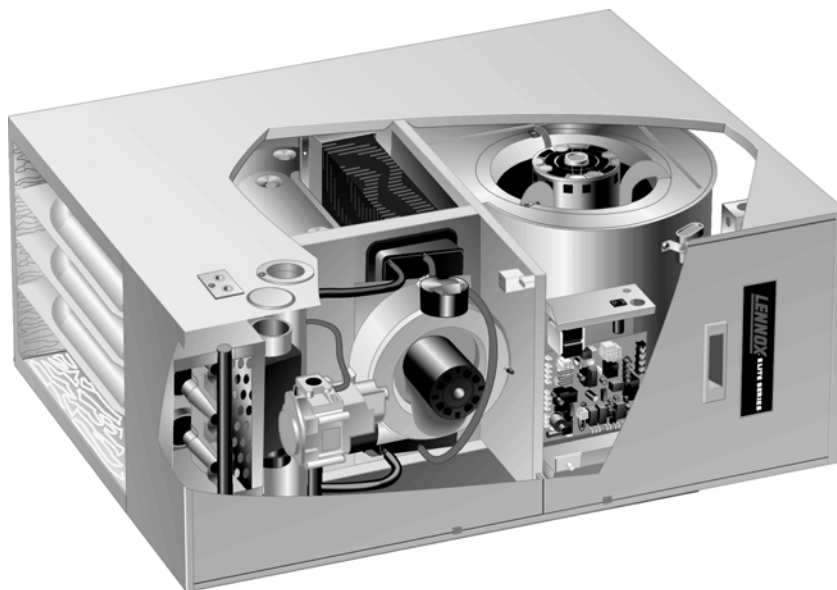

SPECIFICATIONS

Model No.		GHR26Q2/3-50	GHR26Q3-75	GHR26Q3/4-100	GHR26Q4/5-100	GHR26Q4/5-120	
Input — Btuh (kW)		50,000 (14.7)	75,000 (22.0)	100,000 (29.3)	100,000 (29.3)	120,000 (35.2)	
Output — Btuh (kW)		47,000 (13.8)	70,000 (20.5)	92,000 (27.0)	93,000 (27.2)	111,000 (32.5)	
●A.F.U.E.		92%	90%	90%	92%	90%	
California Seasonal Efficiency		85%	84%	84%	85%	84%	
†Exhaust pipe connection (PVC) diameter— in. (mm)		2 (51)	2 (51)	2 (51)	2 (51)	2 (51)	
†Intake pipe connection (PVC) diameter— in. (mm)		2 (51)	2 (51)	2 (51)	2 (51)	2 (51)	
Condensate drain connection (PVC)— in. (mm)		1/2 (12.7)	1/2 (12.7)	1/2 (12.7)	1/2 (12.7)	1/2 (12.7)	
Temperature rise range — °F (°C)		30-60 (17-33)	40-70 (22-39)	50-80 (28-44)	40-70 (22-39)	45-75 (25-42)	
High static certified by (A.G.A./C.G.A.) — in wg. (Pa)		.50 (125)	.50 (125)	.50 (125)	.50 (125)	.50 (125)	
Gas Piping Size I.P.S. Natural or *LPG/propane	in.	1/2	1/2	1/2	1/2	1/2	
	mm	12.7	12.7	12.7	12.7	12.7	
Blower wheel nominal diameter x width	in.	10 x 8	10 x 8	10 x 10	11-1/2 x 9	11-1/2 x 9	
	mm	254 x 203	254 x 203	254 x 254	292 x 229	292 x 229	
Blower motor output — hp (W)		1/3 (249)	1/2 (373)	1/2 (373)	3/4 (560)	3/4 (560)	
★Number and size of filters	in.	(1) 14 x 25 x 1		(1) 20 x 25 x 1			
	mm	(1) 356 x 635 x 25		(1) 508 x 635 x 25			
Nominal cooling that can be added	Tons	2 to 3	2 to 3.5	2 to 4	3.5 to 5	3.5 to 5	
	kW	7.0 to 10.6	7.0 to 12.3	7.0 to 14.1	12.3 to 17.6	12.3 to 17.6	
Shipping weight — lbs. (kg) 1 package		147 (67)	155 (70)	183 (83)	196 (89)	205 (93)	
Electrical characteristics		120 volts — 60 hertz — 1 phase (All units) less than 12 amps					
↘ Optional Accessories (Must Be Ordered Extra) ↙							
*LPG/Propane kit		30M53					
Down-Flow Additive Base Shipping Weight — lbs. (kg.)		30K52	30K52	30K53	30K53	30K53	
Twinning Kit	Non-continuous low speed	64H88 (all models)					
	Continuous low speed	35J93 (all models)					
†Vent/ Intake Kits	Roof Termination Kits	2 inch (51 mm)	15F75				
		3 inch (76 mm)	44J41				
	Concentric Roof Termination Kits		60G77 1 1/2 inch (38 mm)	33K97 2 inch (51 mm) 60L46 - 3 inch (76 mm)			
	Wall Termination Kits	2 inch (51 mm)	15F74 (ring kit) — 22G44 or 30G28 (close couple) — 30G79 (close couple with ext. riser)				
		3 inch (76 mm)	44J40 (close couple) — 81J20 (close couple with ext. riser)				
Condensate Drain Heat Cable		26K68 6 ft. (1.8 m) — 26K69 24 ft. (7.3 m) — 26K70 50 ft. (15.2 m)					
Heat Cable Tape		39G04 1/2 inch (13 mm) wide or 39G03 2 inch (51 mm) wide					

●Annual Fuel Utilization Efficiency based on U.S. DOE test procedures and FTC labeling regulations. Isolated combustion system rating for non-weatherized furnaces.

*LPG/Propane kit must be ordered extra for field changeover.

†Determine from venting tables proper intake and exhaust pipe size and termination kit required.

★Cleanable polyurethane frame type filter.

**BLOWER PERFORMANCE DATA
GHR26Q2/3-50 BLOWER PERFORMANCE**

External Static Pressure		Air Volume and Motor Watts at Specific Blower Taps											
		High			Medium-High			Medium-Low			Low		
in. w.g.	Pa	cfm	L/s	Watts	cfm	L/s	Watts	cfm	L/s	Watts	cfm	L/s	Watts
0	0	1480	700	640	1330	630	520	1070	505	435	900	425	355
.10	25	1430	675	615	1290	610	500	1050	495	420	880	415	346
.20	50	1380	650	595	1240	585	480	1040	490	400	870	410	330
.30	75	1320	625	570	1200	565	455	1010	475	380	850	400	320
.40	100	1260	595	545	1140	540	430	980	460	370	820	385	300
.50	125	1200	565	520	1080	510	410	930	440	320	790	375	280
.60	150	1100	520	500	1000	470	385	860	405	300	740	350	265
.70	175	1000	470	470	890	420	370	750	355	290	660	310	250
.80	200	800	380	440	700	330	340	590	280	280	550	260	240

NOTE — All air data is measured external to unit with air filter in place.

GHR26Q3-75 BLOWER PERFORMANCE

External Static Pressure		Air Volume and Motor Watts at Specific Blower Taps											
		High			Medium-High			Medium-Low			Low		
in. w.g.	Pa	cfm	L/s	Watts	cfm	L/s	Watts	cfm	L/s	Watts	cfm	L/s	Watts
0	0	1650	780	720	1540	725	585	1450	685	540	1230	580	450
.10	25	1590	750	660	1490	705	550	1400	660	505	1200	565	420
.20	50	1520	715	645	1430	675	520	1350	635	485	1170	550	405
.30	75	1440	680	630	1370	645	490	1300	615	450	1130	535	390
.40	100	1370	645	610	1300	615	470	1240	585	430	1090	515	370
.50	125	1300	615	590	1240	585	450	1170	550	410	1040	490	330
.60	150	1210	570	560	1170	550	430	1100	520	375	970	460	320
.70	175	1120	530	540	1080	510	410	1020	480	350	890	420	280
.80	200	1020	480	515	980	460	380	900	425	325	750	355	260
.90	225	880	415	500	820	385	350	750	355	300	600	285	240

NOTE — All air data is measured external to unit with air filter in place.

GHR26Q3/4-100 BLOWER PERFORMANCE

External Static Pressure		Air Volume and Motor Watts at Specific Blower Taps											
		High			Medium-High			Medium-Low			Low		
in. w.g.	Pa	cfm	L/s	Watts	cfm	L/s	Watts	cfm	L/s	Watts	cfm	L/s	Watts
0	0	2020	955	870	1780	840	700	1620	765	635	1320	625	500
.10	25	1950	920	830	1720	810	650	1580	745	580	1300	615	470
.20	50	1870	880	785	1680	795	610	1520	715	560	1260	595	440
.30	75	1780	840	760	1600	755	585	1460	690	540	1220	575	425
.40	100	1690	800	740	1520	715	570	1400	660	500	1180	555	410
.50	125	1590	750	695	1430	675	525	1310	620	460	1110	525	385
.60	150	1480	700	650	1330	630	485	1220	575	430	1040	490	350
.70	175	1350	635	615	1220	575	445	1120	530	390	950	450	320
.80	200	1210	570	580	1100	520	420	1000	470	370	850	400	310
.90	225	1050	495	560	960	455	390	880	415	350	720	340	300
1.00	250	900	425	540	800	380	370	700	330	330	600	285	290

NOTE — All air data is measured external to unit with air filter in place.

GHR26Q4/5-100 BLOWER PERFORMANCE

External Static Pressure		Air Volume and Motor Watts at Specific Blower Taps														
		High			Medium-High			Medium			Medium-Low			Low		
in. w.g.	Pa	cfm	L/s	Watts	cfm	L/s	Watts	cfm	L/s	Watts	cfm	L/s	Watts	cfm	L/s	Watts
0	0	2530	1195	1360	2300	1085	1210	2030	960	1050	1780	840	885	1540	725	745
.10	25	2460	1160	1290	2250	1060	1140	2010	950	1010	1760	830	850	1530	720	730
.20	50	2380	1125	1270	2200	1040	1100	1990	940	990	1740	820	830	1520	715	720
.30	75	2310	1090	1250	2150	1015	1080	1950	920	970	1720	810	805	1510	715	710
.40	100	2250	1060	1200	2090	985	1060	1910	900	950	1690	800	790	1500	710	690
.50	125	2180	1030	1150	2020	955	1020	1870	880	910	1660	785	780	1480	700	670
.60	150	2100	990	1100	1960	925	980	1810	855	870	1620	765	760	1430	675	650
.70	175	2010	950	1070	1880	885	940	1750	825	855	1570	740	730	1380	650	630
.80	200	1910	900	1040	1800	850	920	1680	795	840	1500	710	710	1320	625	615
.90	225	1800	850	1010	1700	800	890	1580	745	800	1420	670	690	1240	585	600
1.00	250	1700	800	980	1600	755	870	1500	710	780	1320	625	670	1120	530	590

NOTE — All air data is measured external to unit with air filter in place.

BLOWER PERFORMANCE DATA (continued)

GHR26Q4/5-120 BLOWER PERFORMANCE

External Static Pressure		Air Volume and Motor Watts at Specific Blower Taps														
		High			Medium-High			Medium			Medium-Low			Low		
in. w.g.	Pa	cfm	L/s	Watts	cfm	L/s	Watts	cfm	L/s	Watts	cfm	L/s	Watts	cfm	L/s	Watts
0	0	2400	1135	1250	2270	1070	1140	2060	970	1010	1800	850	860	1560	735	720
.10	25	2350	1110	1220	2220	1050	1100	2040	965	980	1780	840	830	1550	730	705
.20	50	2290	1080	1200	2170	1025	1080	2000	945	960	1750	825	815	1540	725	685
.30	75	2220	1050	1180	2120	1000	1060	1960	925	940	1720	810	800	1520	715	675
.40	100	2150	1015	1130	2050	965	1020	1900	895	920	1680	795	770	1500	710	660
.50	125	2080	980	1100	1980	935	980	1850	875	880	1640	775	750	1460	690	650
.60	150	2000	945	1050	1910	900	940	1780	840	840	1590	750	720	1420	670	630
.70	175	1900	895	1010	1830	865	920	1710	805	810	1530	720	690	1380	650	610
.80	200	1800	850	980	1740	820	900	1630	770	790	1460	690	675	1320	625	595
.90	225	1700	800	960	1630	770	860	1540	725	770	1380	650	660	1250	590	580
1.00	250	1600	755	940	1530	720	840	1430	675	750	1300	615	640	1150	545	560

NOTE — All air data is measured external to unit with air filter in place.

INTAKE AND EXHAUST PIPE VENTING TABLE

Vent Pipe Maximum Equivalent Length		Minimum Vent Pipe Diameter Required							
		50,000 Btuh (14.7 kW)		75,000 Btuh (22.0 kW)		100,000 Btuh (29.3 kW)		120,000 Btuh (35.2 kW)	
Feet	Meters	in.	mm	in.	mm	in.	mm	in.	mm
15	4.6	1-1/2	38	2	51	2	51	2	51
20	6.1	2	51	2	51	2	51	3	76
25	7.6	2	51	2	51	2	51	3	76
30	9.1	2	51	2	51	3	51	3	76
40	12.2	2	51	2	51	3	51	3	76
50	15.2	2	51	2	51	3	51	3	76
55	16.8	2	51	2	51	3	76	3	76
60	18.3	3	76	3	76	3	76	3	76
70	21.3	3	76	3	76	3	76	3	76
80	24.4	3	76	3	76	3	76	3	76
90	27.4	3	76	3	76	3	76	3	76
100	30.5	3	76	3	76	3	76	3	76
110	33.5	3	76	3	76	3	76	3	76
120	36.6	3	76	3	76	3	76	3	76
130	39.6	3	76	3	76	3	76	----	----

MINIMUM PIPE LENGTHS FOR FURNACES — **GHR26-50** — 5 feet (1.5 m) with two 90° elbows of 1-1/2 inch (38 mm) diameter pipe. (15 equivalent feet (4.6 m) total).
GHR26-75 — 5 feet (1.5 m) with two 90° elbows of 2 inch (51 mm) diameter pipe. (15 equivalent feet (4.6 m) total).
GHR26-100 — 5 feet (1.5 m) with two 90° elbows of 2 inch (51 mm) diameter pipe. (15 equivalent feet (4.6 m) total).
GHR26-120 — 5 feet (1.5 m) with two 90° elbows of 2 inch (51 mm) diameter pipe. (15 equivalent feet (4.6 m) total).

VENTING NOTES — One 90° elbow is equivalent to 5 feet (1.5 m) of straight vent pipe.
 Two 45° elbows are equal to one 90° elbow.
 One 45° elbow is equivalent to 2.5 feet (.75 m) of straight vent pipe.
 One foot (305 mm) length of 2 in. (51 mm) diameter pipe is equivalent to eight feet (2.4 m) of 3 in. (76 mm) diameter pipe.
 Intake and Exhaust pipes must be the same diameter.
 2 inch x 3 inch (51 mm x 76 mm) adaptor is furnished with -100 and -125 furnaces for exhaust pipe connection.
 Exhaust pipe must terminate with 1-1/2 inch (38 mm) diameter pipe for furnaces using 1-1/2 (38 mm) or 2 inch (51 mm) diameter pipe runs.
 Exhaust pipe must terminate with 2 inch (51 mm) diameter pipe for furnaces using 3 inch (76 mm) diameter pipe runs.

GHR26 COMPONENTS (Down-flow Application Shown)

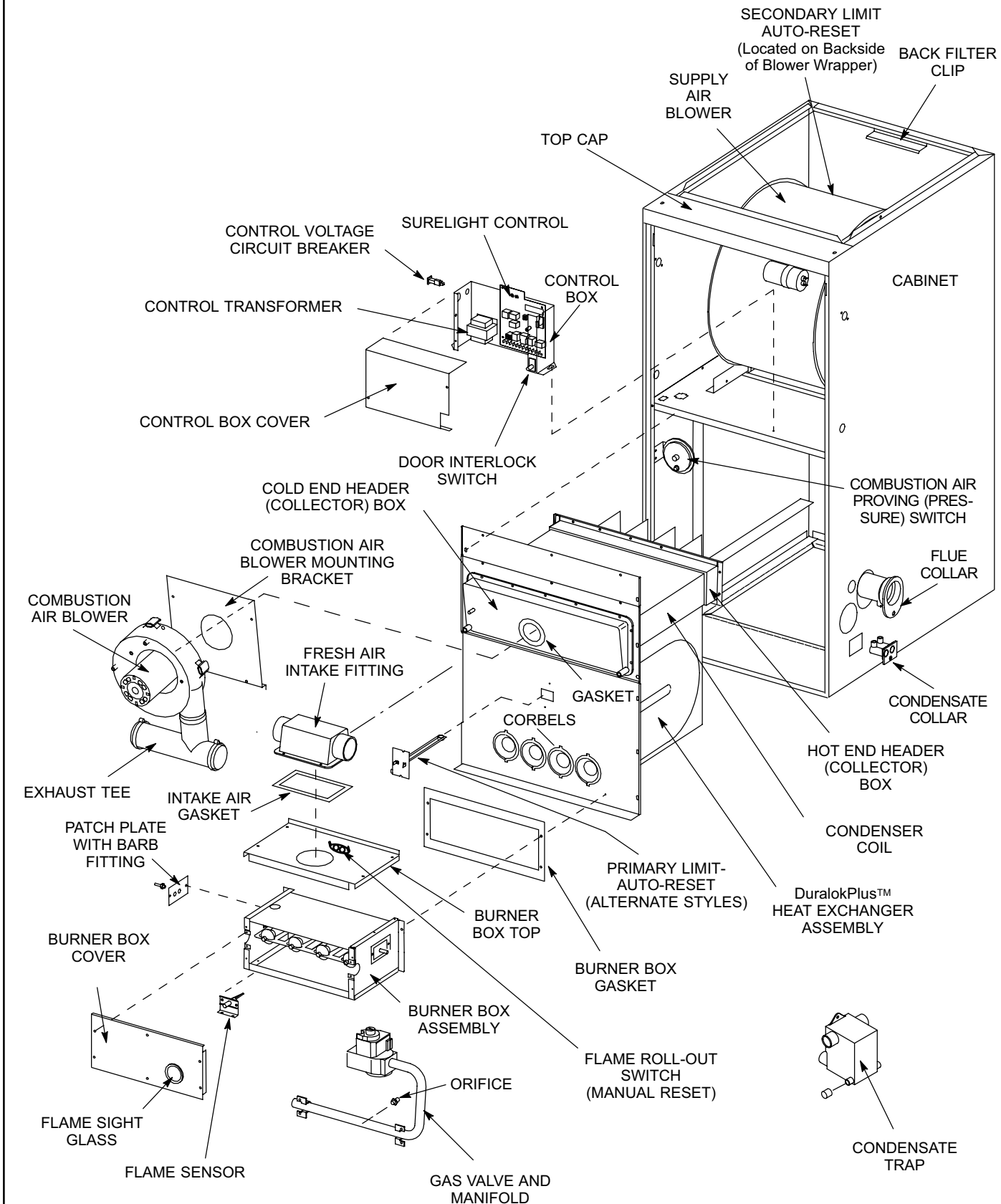

FIGURE 1

GHR26 GENERAL PARTS ORIENTATION

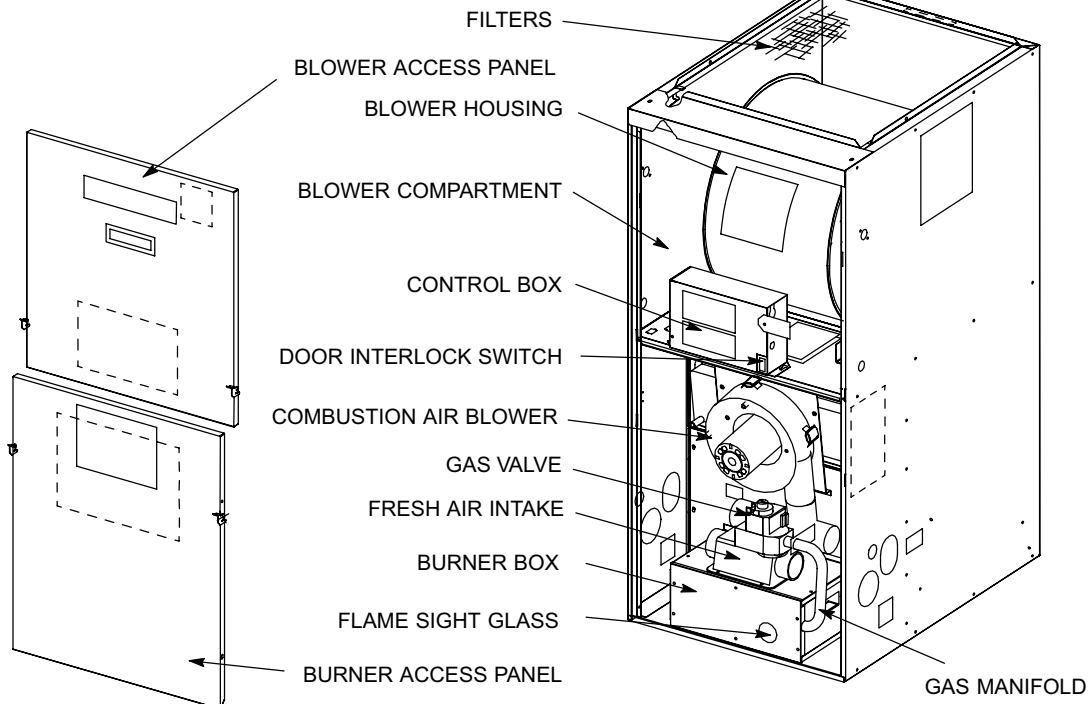

FIGURE 2

I-UNIT COMPONENTS

GHR26 unit components are shown in figure 1. General parts orientation is shown in figure 2. The combustion air blower, gas valve and burners can be accessed by removing the burner access panel. The blower and control box can be accessed by removing the blower access door.

A-Make-Up Box (Figure 3)

A field make-up box (see figure 3) is provided for line voltage wiring. Line voltage wiring to unit is done through the J96 jack from the field make-up box to plug P96 from the control box. The box may be installed inside or outside the unit (see figures 4 and 5) and may be installed on the unit left or right side.

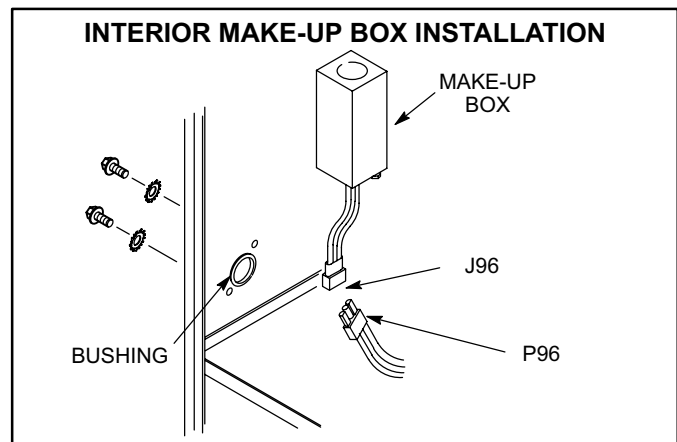

FIGURE 4

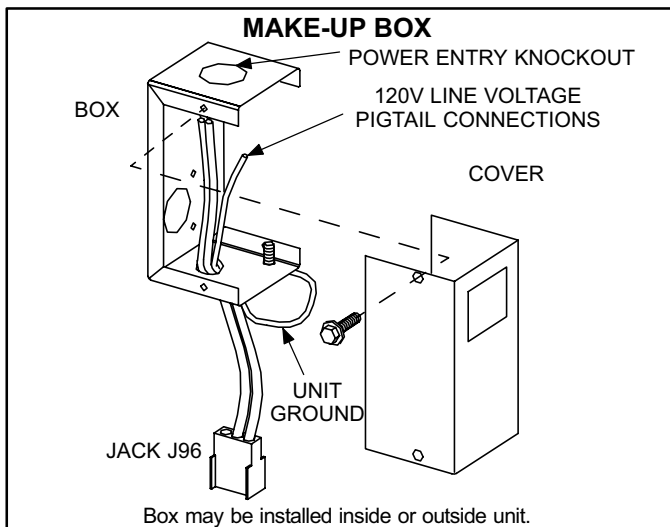

FIGURE 3

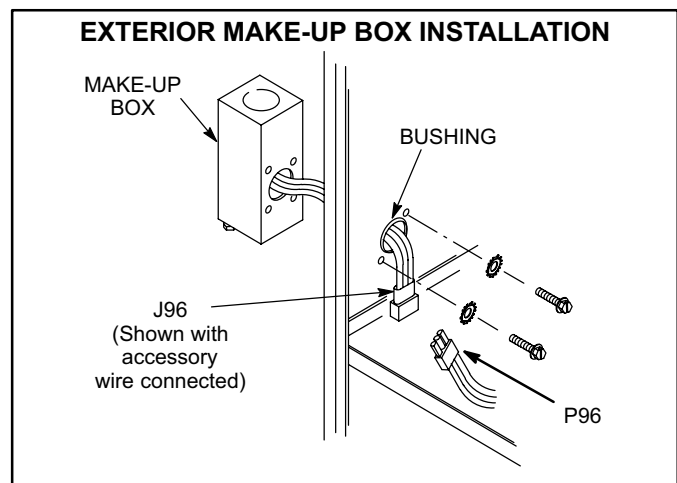

FIGURE 5

An accessory (brown) output wire is provided with the make-up box. The wire provides a 120V connection for optional accessories such as electronic air cleaner or humidifier. If used, the wire is field installed in J96 jack plug by inserting the pin of the brown wire into the open socket of the jack. See figure 6. 120V accessories rated up to 4 amps total may be connected to this wire. The neutral leg of the accessory is connected to the neutral white wire in the make-up box. The accessory terminal is energized whenever the indoor blower is in operation. Two additional accessory terminals are available on the EGC-1 board. See figure 10 for the locations.

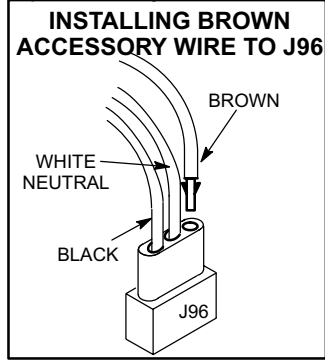

FIGURE 6

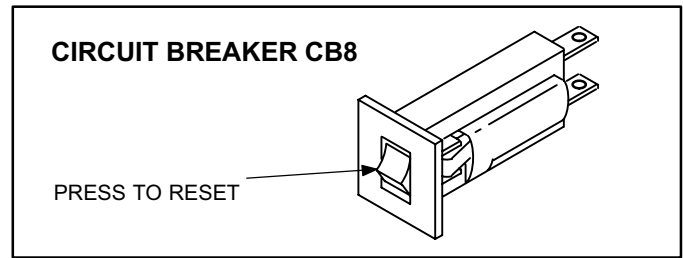

FIGURE 8

3-Door Interlock Switch (S51)

A door interlock switch rated 14A at 125VAC is located on the control box. The switch is wired in series with line voltage. When the blower door is removed the unit will shut down.

4- Integrated Control EGC-1 (A3) -1 models

GHR26-1 units are equipped with an integrated ignition/blower control (EGC-1) which controls ignition, safety circuits, blower operation, fan off timing, and allows for thermostat connection and troubleshooting. The EGC-1 is a printed circuit board which is divided into two sections, 120 and 24VAC. Line voltage comes into the board on the 120VAC side. See figure 10. Terminal designations are listed in tables 2 and 3.

Ignition Control

GHR26-1 units use direct spark ignition which is controlled by the EGC-1. The EGC-1 controls and monitors the entire sequence of operation. On a call for heat from the thermostat the control monitors the combustion air blower pressure switch. The control will not begin the heating cycle if the pressure switch is closed (by-passed). Once the pressure switch is determined to be opened, the combustion air blower is energized. When the differential in pressure across the pressure switch is great enough, the pressure switch closes and a 15 second pre-purge period begins. After the pre-purge period, the gas valve will open and ignition (spark) will be attempted for 10 seconds. After ignition, the control initiates a ten second flame stabilization period. The flame stabilization period allows the burners to heat up and the flame to stabilize. Once flame is established, the control will constantly monitor the burner flame using flame rectification. Flame failure response time is 0.8 seconds. If the initial attempt for ignition fails, the sequence is repeated up to five times. After the fifth trial, the control goes into "Watchguard"*. During watchguard mode, the entire unit will be de-energized for one hour. After one hour the control will repeat the ignition sequence. Watchguard may be manually reset by breaking and remaking thermostat demand.

**NOTE-If flame is established beyond the 10 second flame stabilization period then lost, the control resets for five more ignition trials. The control can be reset five times during one unsatisfied thermostat demand, providing a maximum of 25 trials for ignition.*

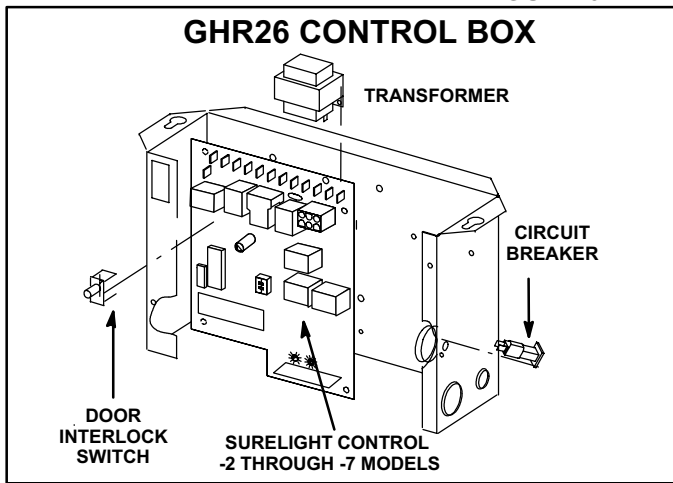

FIGURE 7

B-Control Box Components (Figure 7)

Unit transformer (T1), circuit breaker (CB8), and integrated control EGC-1 or SureLight (A3) are located in the control box. In addition, a door interlock switch (S51) is located in the control box. Jackplugs and a "snap-off" terminal strip allow the control box to be easily removed for blower service.

1- Control Transformer (T1)

A transformer located in the control box provides power to the low voltage 24 volt section of the unit. Transformers on all models are rated 40VA with a 120V primary and a 24V secondary.

2- Circuit Breaker (CB8)

A 24V circuit breaker is also located in the control box. The switch provides overcurrent protection to the transformer (T1). The breaker is rated 3A at 32V. If the current exceeds this limit the breaker will trip and all unit operation will shut down. The breaker can be manually reset by pressing the button on the face (figure 8).

Safety Circuits

During the entire heating demand the control monitors the safety circuits. If the primary or secondary heating limits open, the control de-energizes the main gas valve and combustion air blower while the indoor blower remains energized. When the limit automatically resets, the ignition sequence also resets. If either of the limits trip five consecutive times, the control will go into watchguard for one hour.

The control monitors main valve voltage. If voltage is sensed when no voltage should be present, the control de-energizes the combustion air blower which terminates voltage to the valve. The system goes into hard lock-out which is reset only by removing power to the unit.

If flame is sensed when no flame should be present, the control will energize the combustion and indoor blowers. The unit will remain locked in this sequence until the flame is no longer sensed or the main power is turned off to reset the control.

The roll-out circuit is also monitored by the EGC-1 control. If the switch opens, the control will de-energize the gas valve, combustion air blower, and indoor blower. The unit will remain de-energized until the switch is manually reset.

⚠ DANGER

Shock hazard. Avoid personal injury. Make sure to disconnect power before changing fan "off" timing.

Blower Operation / Fan Off Timings

Fan "off" timing (time that the blower operates after the heat demand has been satisfied) can be adjusted by moving the jumper on the EGC-1 blower control board. Figure 9 shows the various fan "off" timings and how jumper should be positioned. To adjust fan "off" timing, gently disconnect jumper and reposition across pins corresponding with new timing. Unit is shipped with a factory fan "off" setting of 60 seconds. Fan "on" time is factory set at 45 seconds following the opening of the main gas valve and is not adjustable.

Fan "off" time will affect comfort and efficiency and is adjustable to satisfy individual applications. The fan "off" timing is initiated after a heating demand but not after a cooling demand.

NOTE—If fan "off" time is set too low, residual heat in heat exchanger may cause primary limit S10 to trip, resulting in frequent cycling of blower. If this occurs, adjust blower to longer fan "off" time setting.

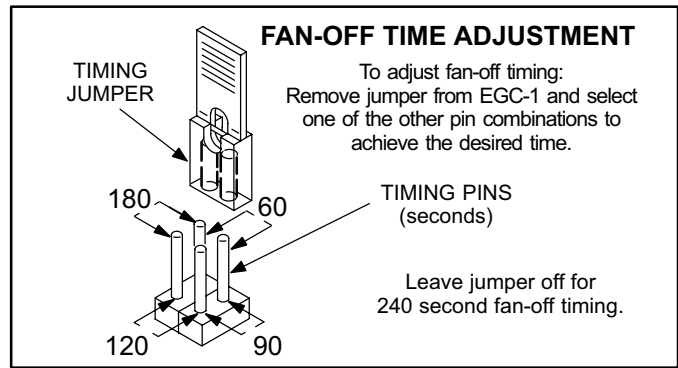

FIGURE 9

Thermostat Connection

Thermostat wires are connected to the terminal strip found on the EGC-1 control board. The terminal strip is clearly marked with the corresponding thermostat designation. On early model controls the terminal strip is simply removed by grasping the ends of the block and rotating down while pulling away (see figure 10).

Troubleshooting

The EGC-1 control board is equipped with two diagnostic green LEDs to indicate the mode of failure. The LED lights are marked DIAG #1 and DIAG #2. The codes are given in table 1. The last failure code is stored in memory and may be retrieved by depressing and holding the memory recall button. When this button is depressed, the LEDs will signal the last failure code in memory. Power must be restored to the control (depress blower interlock switch) within one minute of blower access panel removal in order to retain memory. To clear the memory of the stored failure code, remove main power and short the jumper next to the diagnostic button for five seconds.

TABLE 1

EGC-1 DIAGNOSTIC CODES		
DIAG #2	DIAG #1	Diagnostic Condition
Simultaneous Flash	Simultaneous Flash	Power "ON". Normal Operation. Increased flash rate indicates there is a heating demand.
On	Flash	Primary or Secondary Limit Switch Open. Auto-Reset Switch.
Flash	Off	Pressure Switch Watchguard, pressure switch opened during operation or condensate drain blocked.
Alternate Flash	Alternate Flash	Watchguard, burners failed to ignite.
Off	Flash	Flame sensed without valve energized.
Flash	On	Roll-out Switch Open. Manual-Reset Switch.
Continuous On	Continuous On	Circuit board self-check failure or ignition/blower control is wired incorrectly.

A slotted edge connector is also provided for the Lennox Diagnostic Module (part number 11K75). See figure 10. When connected to the EGC-1 control board, the module displays (in words) the diagnostic condition.

GHR26-1 MODEL INTEGRATED CONTROL (EGC-1)
 (Shown as installed in horizontal left hand application)
 (See tables 2 and 3 for terminal designations)

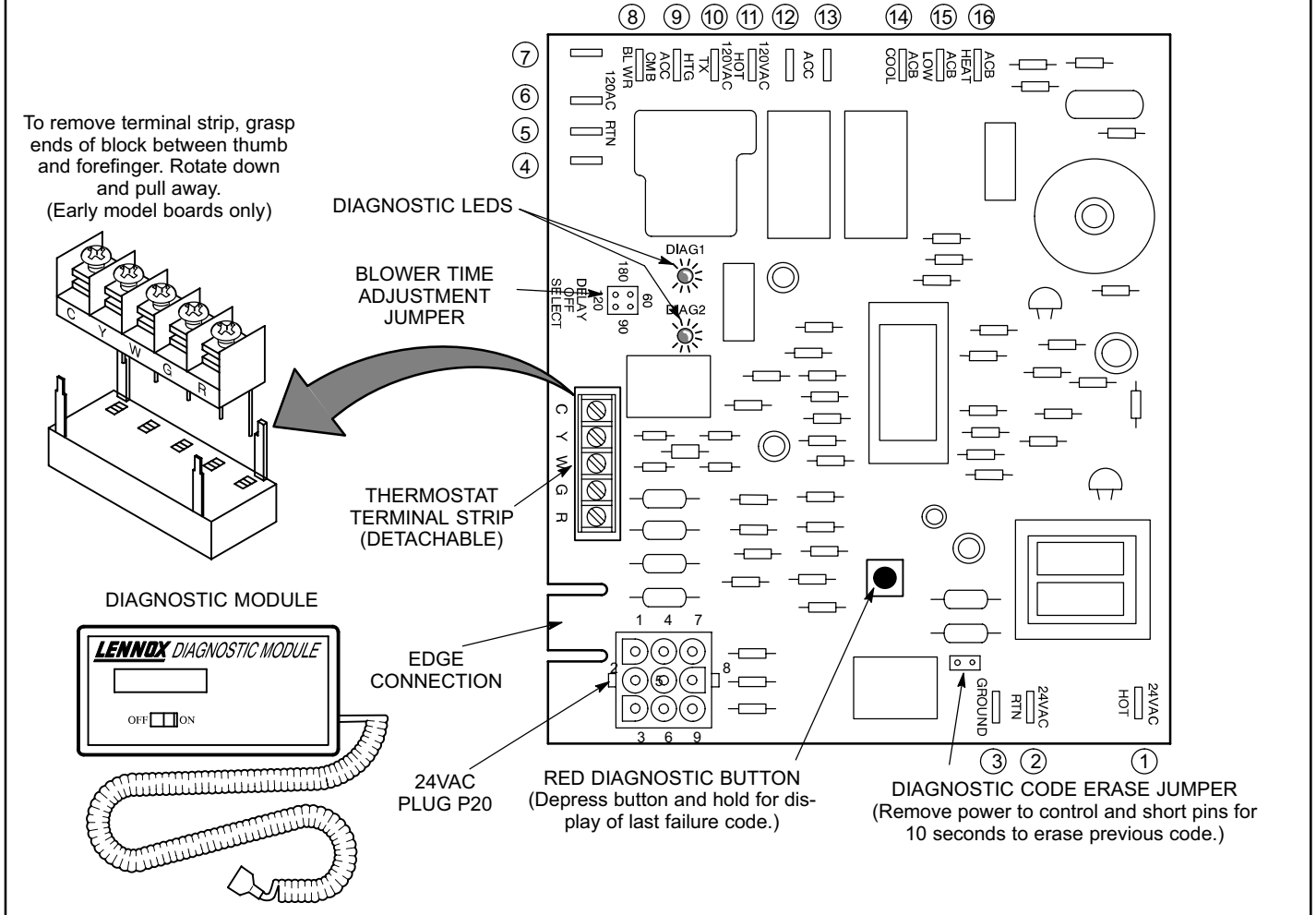

FIGURE 10

TABLE 2

BLOWER CONTROL A15 TERMINAL DESIGNATIONS		
Terminal Designation (See fig. 10)	Type	Function
R	Detachable Screw Strip	24VAC to Thermostat (Red)
G	Detachable Screw Strip	Manual Fan Input from Thermostat (Green)
W	Detachable Screw Strip	Heat Demand Input from Thermostat (White)
Y	Detachable Screw Strip	Cool Demand Input from Thermostat (Yellow)
C	Detachable Screw Strip	Common Ground to Thermostat
1	1/4" Spade	24VAC Hot from Transformer
2	1/4" Spade	24VAC Return to Transformer
3	1/4" Spade	24VAC Ground
4, 5, 6	1/4" Spade	120VAC Return - 120VAC Common
7	1/4" Spade	120VAC Return - 120VAC Common Input
8	1/4" Spade	Combustion Blower (Line Voltage)
9	1/4" Spade	Heat Only Accessory (Line Voltage)
10	1/4" Spade	120VAC Hot to Transformer
11	1/4" Spade	120VAC Hot Input
12, 13	1/4" Spade	Accessories (Line Voltage)
14	1/4" Spade	ACB Cool Speed (Line Voltage)
15	1/4" Spade	ACB Low Cont. Speed (Line Voltage)
16	1/4" Spade	ACB Heat Speed (Line Voltage)

TABLE 3

EGC-1 CONTROL JACK/PLUG 20 TERMINAL DESIGNATIONS	
Pin #	Function
1	Rollout Switch Out
2	Spare
3	Gas Valve Common
4	Pressure Switch Return
5	Hi Limit Return / Pressure Switch Out
6	Flame Sensor
7	Gas Valve Out
8	High Limit Out
9	Rollout Switch Return

⚠ DANGER

Shock hazard.

Disconnect power before servicing. Control is not field repairable. If control is inoperable, simply replace entire control.

Can cause injury or death. Unsafe operation will result if repair is attempted.

5- SureLight Ignition System A3 (-2 through -7 models)

All GHR26-2 through -7 units are equipped with the Lennox SureLight ignition system. The system consists of ignitor (figure 11) and ignition control board (figure 12). The board and ignitor work in combination to ensure furnace ignition and ignitor durability. The SureLight integrated board controls all major furnace operations. Table 4 and 5 show jack plug terminal designations. The board also features two LED lights for troubleshooting and two accessory terminals rated at (4) four amps. See table 6 for troubleshooting diagnostic codes. Units equipped with the SureLight board can be used with either electronic or electro-mechanical thermostats without modification. The SureLight ignitor is made of durable silicon nitride. Ignitor longevity is also enhanced by voltage ramping by the control board. The board finds the lowest ignitor temperature which will successfully light the burner, thus increasing the life of the ignitor.

NOTE - Do not remove blower access panel to read Surelight LED lights. A sight glass is provided on the access panel for viewing.

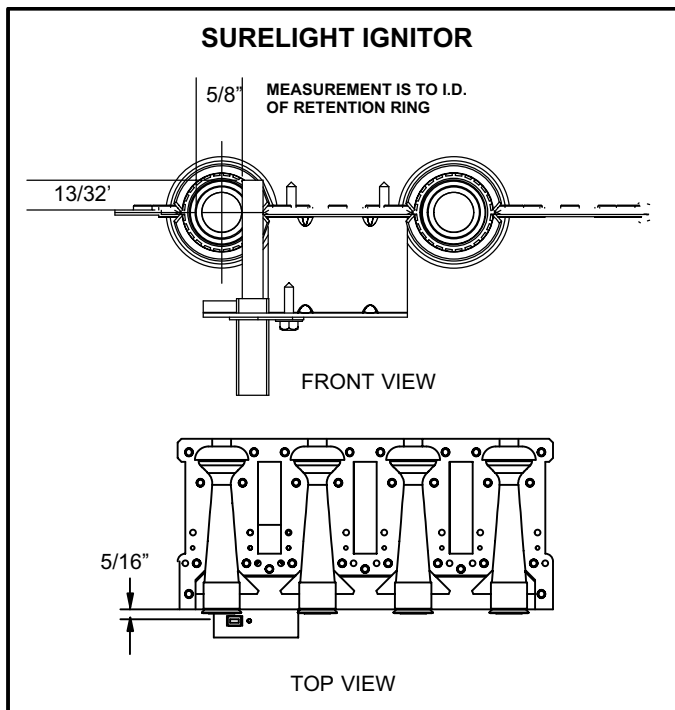

FIGURE 11

TABLE 4

SureLight BOARD J156 (J2) TERMINAL DESIGNATIONS	
PIN #	FUNCTION
1	Ignitor
2	Not Used
3	Ignitor Neutral
4	Combustion Air Blower Line Voltage
5	Not Used
6	Combustion Air Blower Neutral

TABLE 5

SureLight BOARD J58 (J1) TERMINAL DESIGNATIONS	
PIN #	FUNCTION
1	Primary Limit In
2	Gas Valve Common
3	Roll Out Switch Out
4	Gas Valve 24V
5	Pressure Switch In
6	Pressure Switch and Primary Limit Out
7	Not Used
8	Roll Out Switch In
9	Ground

ELECTROSTATIC DISCHARGE (ESD)

Precautions and Procedures

⚠ CAUTION

Electrostatic discharge can affect electronic components. Take precautions during furnace installation and service to protect the furnace's electronic controls. Precautions will help to avoid control exposure to electrostatic discharge by putting the furnace, the control and the technician at the same electrostatic potential. Neutralize electrostatic charge by touching hand and all tools on an unpainted unit surface, such as the gas valve or blower deck, before performing any service procedure.

**SURELIGHT INTEGRATED CONTROL BOARD
GHR26-2 Through -7 Models**

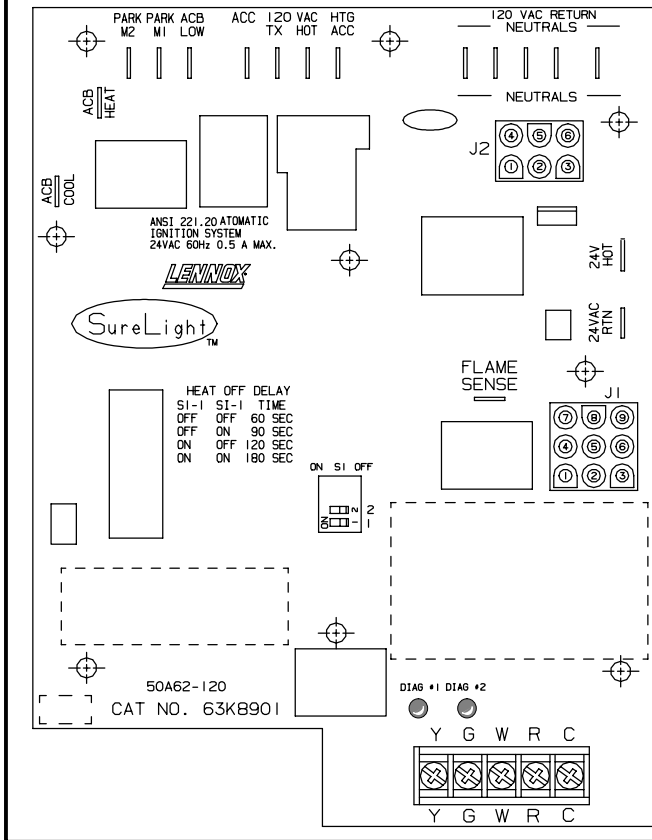

TERMINAL DESIGNATIONS	
ACB COOL	Blower - Cooling Speed (Line Volt)
ACB HEAT	Blower - Heating Speed (Line Volt)
PARK	Alternate Blower Speeds (Dead)
ACB LOW	Continuous Low Speed Blower
ACC	Accessory Terminal (Line Volt)
TX	120VAC Hot to Transformer
HOT	120VAC Hot Input
HTG ACC	Heat Only Accessory (Line Volt)
NEUTRALS	120VAC Neutrals
24VAC HOT	24VAC Hot from Transformer
24VAC RTN	24VAC Return from Transformer
FLAME SENSE	Flame Sense Terminal

FIGURE 12

TABLE 6

DIAGNOSTIC CODES

MAKE SURE TO ID LED'S CORRECTLY: REFER TO INSTALLATION INSTRUCTIONS FOR CONTROL BOARD LAYOUT.

LED #1	LED #2	DESCRIPTION
SIMULTANEOUS SLOW FLASH	SIMULTANEOUS SLOW FLASH	Power - Normal operation Also signaled during cooling and continues fan.
SIMULTANEOUS FAST FLASH	SIMULTANEOUS FAST FLASH	Normal operation - signaled when heating demand initiated at thermostat.
SLOW FLASH	ON	Primary or Secondary limit open. Units with board 63K8901 or 24L85: Limit must close within 5 trials for ignition or board goes into one hour limit Watchguard. Units with board 56L83 or 97L48: Limit must close within 3 minutes or board goes into one hour limit Watchguard.
OFF	SLOW FLASH	Pressure switch open or has opened 5 times during a single call for heat; OR: Blocked inlet/exhaust vent; OR: Condensate line blocked; OR: Pressure switch closed prior to activation of combustion air blower.
ALTERNATING SLOW FLASH	ALTERNATING SLOW FLASH	Watchguard - burners fail to ignite.
SLOW FLASH	OFF	Flame sensed without gas valve energized.
ON	SLOW FLASH	Rollout switch open. OR: 9 pin connector improperly attached.
ON ON OFF	ON OFF ON	Circuit board failure or control wired incorrectly.
FAST FLASH	SLOW FLASH	Main power polarity reversed. Switch line and neutral.
SLOW FLASH	FAST FLASH	Low flame signal. Measures below .7 microAmps. Replace flame sense rod.
ALTERNATING FAST FLASH	ALTERNATING FAST FLASH	Improper main ground or line voltage below 75 volts; OR: Broken ignitor; OR: Open ignitor circuit.

NOTE - Slow flash equals 1 Hz (one flash per second). Fast flash equals 3 Hz (three flashes per second). Drop out flame sense current < 0.15 microAmps

a-Electronic Ignition

(See Ignition Sequence Bars Next Page)

On a call for heat the SureLight control monitors the combustion air blower pressure switch. The control will not begin the heating cycle if the pressure switch is closed (bypassed). Once the pressure switch is determined to be open, the combustion air blower is energized. When the differential in the pressure switch is great enough, the pressure switch closes and a 15-second pre-purge begins. If the pressure switch is not proven within 2-1/2 minutes, the control goes into Watchguard-Pressure Switch mode for a 5-minute re-set period.

After the 15-second pre-purge period, the SureLight ignitor warms up for 20 seconds after which the gas valve opens for a 4-second trial for ignition. GHR26 units with board 63K89, 24L85 or 56L83: the ignitor stays energized for the first second of the 4-second trial. Units with board 97L48: ignitor stays energized during trial or until flame is sensed. If ignition is not proved during the 4-second period, the control will try four more times with an inter-purge and warm-up time between trials of 35 seconds. After a total of five trials for ignition (including the initial trial), the control goes into Watchguard-Flame Failure mode. After a 60-minute reset period, the control will begin the ignition sequence again.

The SureLight control board has an added feature that prolongs the life of the ignitor. After a successful ignition, the SureLight control utilizes less power to energize the ignitor on successive calls for heat. The control continues to ramp down the voltage to the ignitor until it finds the lowest amount of power that will provide a successful ignition. This amount of power is used for 255 cycles. On the 256th call for heat, the control will again ramp down until the lowest power is determined and the cycle begins again.

b-Fan Time Control

The fan on time of 45 seconds is not adjustable. Fan off time (time that the blower operates after the heat demand has been satisfied) can be adjusted by flipping the dip switches located on the SureLight integrated control. The unit is shipped with a factory fan off setting of 90 seconds. Fan off time will affect comfort and is adjustable to satisfy individual applications. See figure 13.

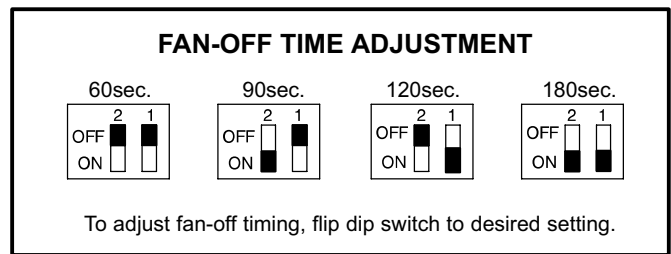

FIGURE 13

c-Flame Sensor

A flame sensor is located on the left side of the burner support. See figure 14. The sensor is mounted on a bracket in the burner support and the tip protrudes into the flame envelope of the left-most burner. The sensor is fastened to burner supports and can be removed for service without removing any part of the burners. During operation, flame is sensed by current passed through the flame and sensing electrode. The SureLight control allows the gas valve to remain open as long as flame signal is sensed.

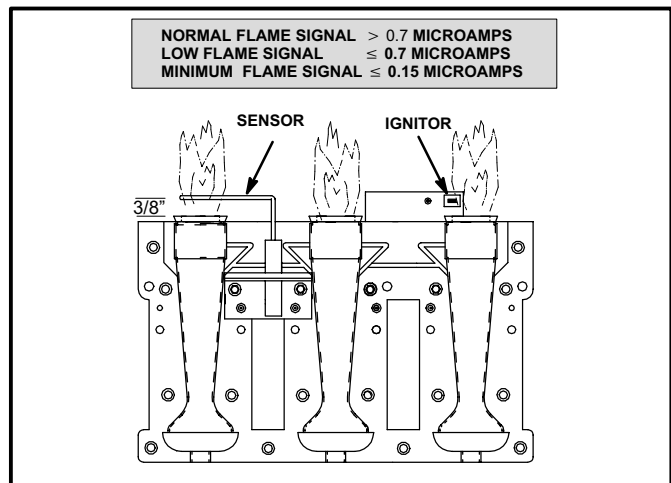

FIGURE 14

NOTE - The GHR26 furnace contains electronic components that are polarity sensitive. Make sure that the furnace is wired correctly and is properly grounded.

GHR26 HEAT EXCHANGER ASSEMBLY

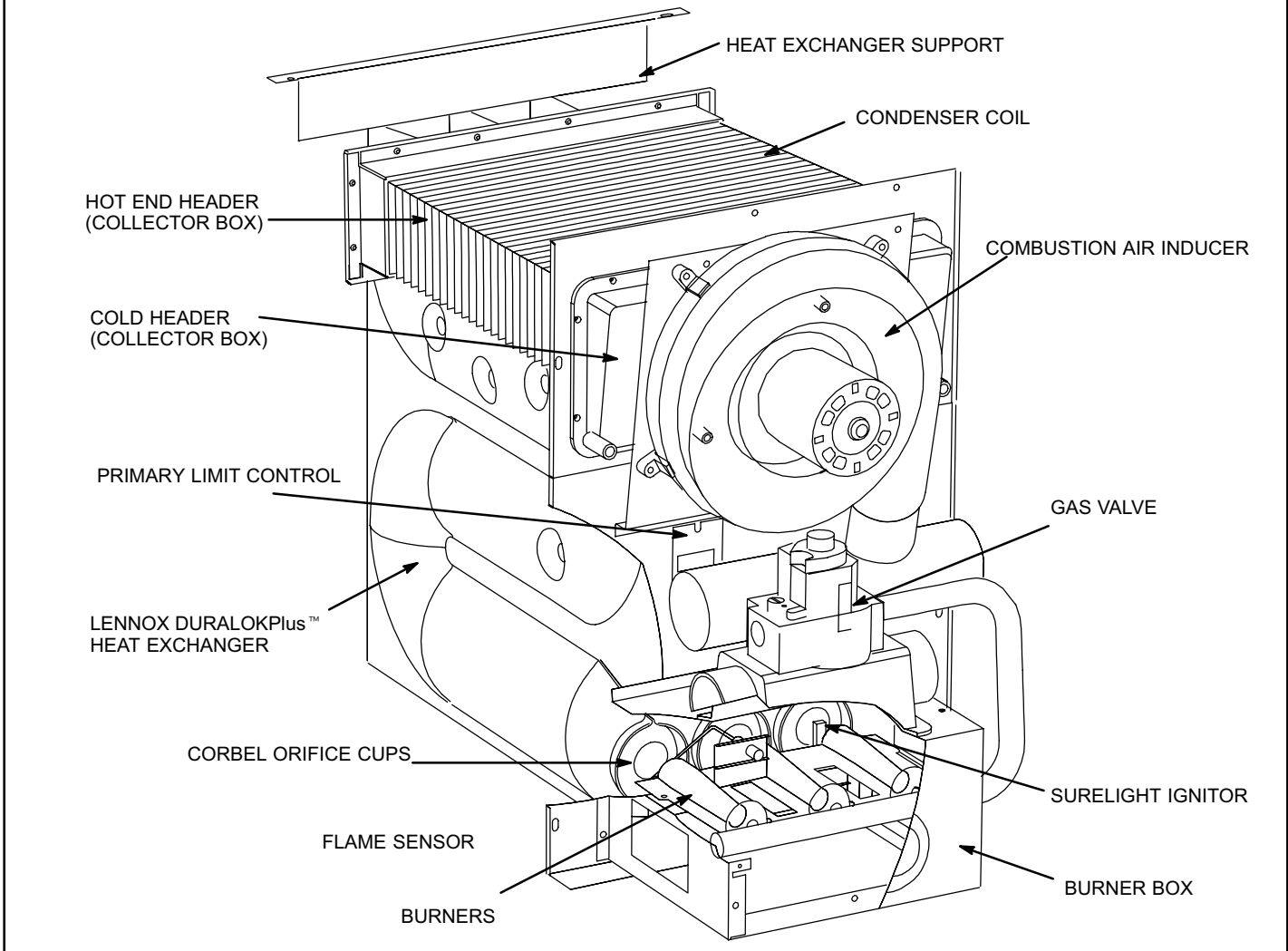
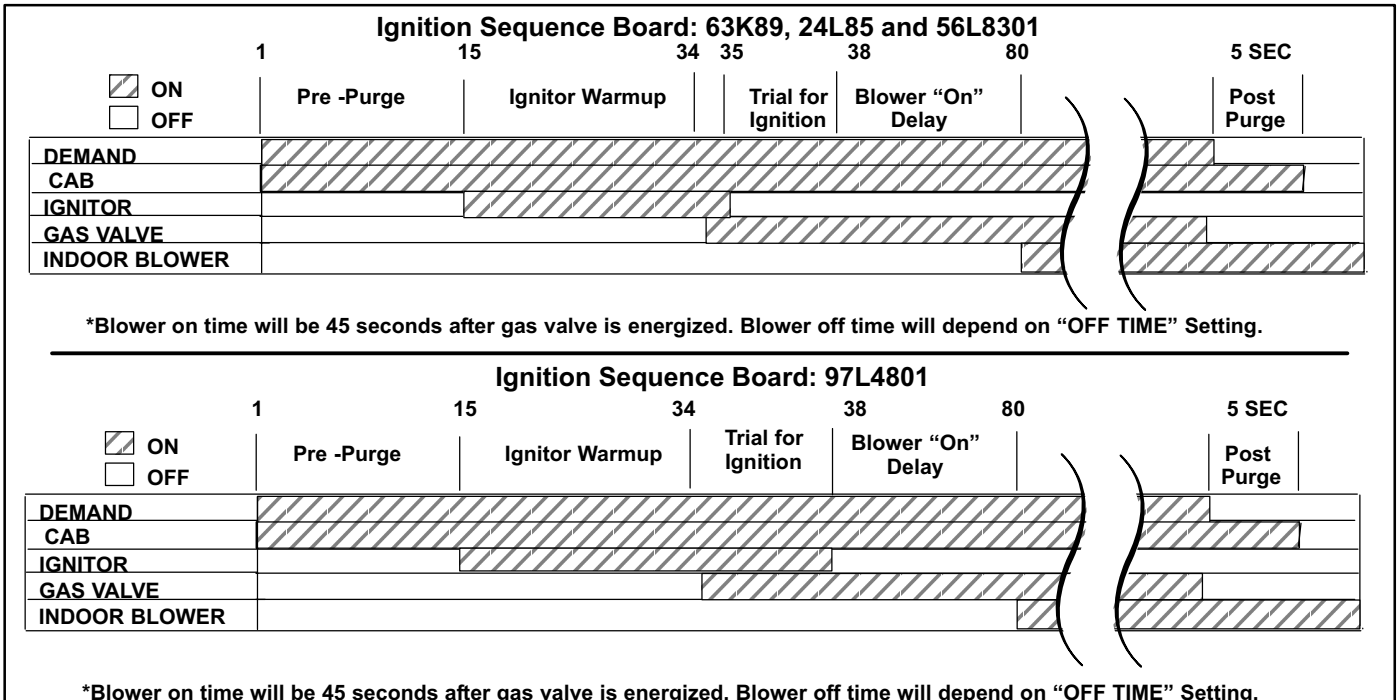

FIGURE 15



C-Heating Components (Figure 15)

Combustion air blower (B6), primary limit control (S10), spark electrode, flame sensor, burners, flame rollout switch (S47), gas valve (GV1), combustion air blower switch (S18), and clamshell heat exchangers are located in the heating compartment. The heating compartment can be accessed by removing the burner access panel.

1-Combustion Air Blower (B6)

All GHR26 units use a combustion air blower to move air through the burners and heat exchanger during heating operation. The blower will use a PSC or shaded pole 120VAC motor. The motor operates during all heating operation and is controlled by burner ignition control A3. Blower operates continuously while there is a call for heat. The burner ignition control will not proceed with the ignition sequence until combustion air blower operation is sensed by the proving switch. Combustion air blowers on GHR26-6 and -7 model units have a gray motor with a black housing and will be shipped as replacement for earlier dash number units.

The combustion air proving switch connected to the cold end header box proves combustion air blower operation. The switch monitors pressure drop across an orifice in the cold header box. If the pressure drop is too low, the pressure switch opens and the ignition control (A3) immediately closes the gas valve to prevent burner operation.

2-Combustion Air Blower Capacitor (C3) PSC Motors only

GHR26 units with a PSC combustion air blower motor, will have a thermally protected 3 MFD 300VAC capacitor. The capacitor is mounted on the combustion air blower housing.

3-Primary Limit Control (S10)

Figure 16 shows the primary limit (S10) used on GHR26 units. S10 is located in the middle of the heating vestibule panel. When excess heat is sensed in the heat exchanger, the limit will open. If the limit is tripped, the furnace control energizes the supply air blower and closes the gas valve. The limit automatically resets when unit temperature returns to normal. The switch is factory set and cannot be adjusted. The switch has a different setpoint for each unit model number. The setpoint is printed on the face plate of the limit.

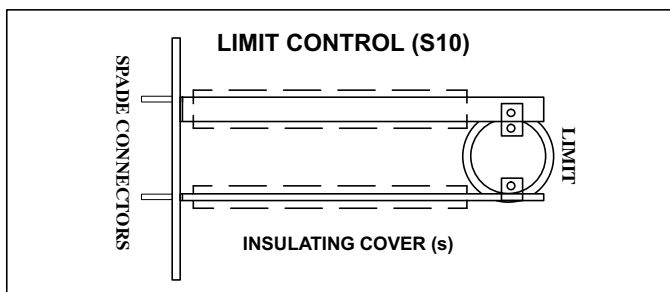

FIGURE 16

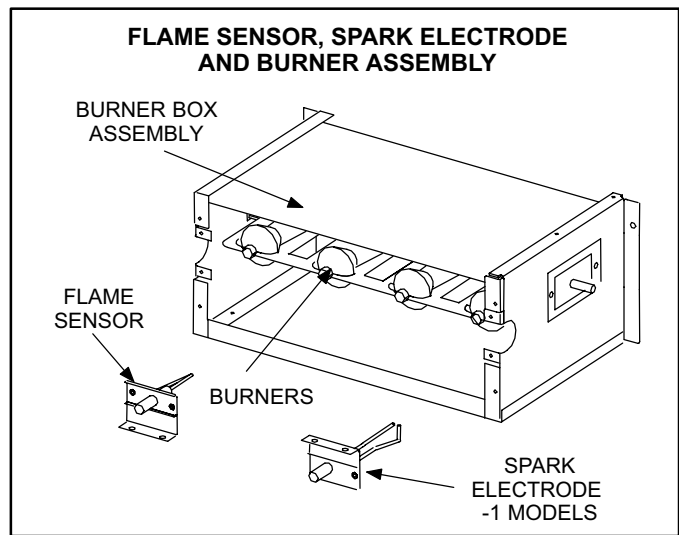

FIGURE 17

4-Burners

Figure 17 shows the arrangement of the spark electrode (-1 models), flame sensor, and burners in the GHR26 series units. Table 7 shows how many burners are used per unit.

TABLE 7

GHR26 UNIT SIZE	NUMBER OF HEAT EXCHANGER CLAMSHELLS / BURNERS
GHR26-50	2
GHR26-75	3
GHR26Q3/4-100	4
GHR26Q4/5-100	4
GHR26-120	5

All units use inshot burners. Burners are factory set and do not require adjustment. A sight glass is furnished in the burner box assembly for flame viewing. Always operate the unit with the burner box cover in place. Burners can be removed as an assembly for service. Burner maintenance and service is detailed in the SERVICE CHECKS sections of this manual. Each burner uses an orifice which is precisely matched to the burner input. The orifice is threaded into the burner manifold. The burner is supported by the orifice and will easily slide off for service. Each orifice and burner are sized specifically to the unit. Refer to Lennox Repair Parts Listing for correct sizing information. A flame retention ring in the end of each burner maintains correct flame length and shape and keeps the flame from lifting off the burner head. In addition, the burner entrance to each clamshell (Figure 15) is fitted with a corbel cup (orifice) used to direct the flow of combustion products.

NOTE-Do not use thread-sealing compound on the orifices. Thread-sealing compound may plug the orifices.

5-Spark Electrodes (-1 models)

An electrode assembly is used for ignition spark. The electrode is mounted through holes on the right-most end of the burner support. The electrode tip protrudes into the flame envelope of the adjacent burner. The electrode assembly is fastened to burner supports and can be removed for service without removing any part of the burners.

During ignition, spark travels across the electrode / ground gap (figure 18) and ignites the right burner. Flame travels from burner to burner until all burners are lit.

The spark electrode is connected to the ignition control by an 7 mm silicone-insulated high voltage wire. The wire uses 1/4" (6.35mm) female quick-connect on the electrode end and 1/4" (6.35mm) quick-connect on the ignition control end.

NOTE-IN ORDER TO MAXIMIZE SPARK ENERGY TO ELECTRODE, HIGH VOLTAGE WIRE SHOULD TOUCH UNIT CABINET AS LITTLE AS POSSIBLE.

6-Flame Sensor (-1 models)

A flame sensor is located on the left side of the burner support. The sensor is mounted through a hole in the burner support and the tip protrudes into the flame envelope of the left-most burner.

During operation, flame is sensed by current passed through the flame and sensing electrode. The ignition control allows the gas valve to stay open as long as a flame signal (current passed through the flame) is sensed.

7-Clamshell Heat Exchanger

GHR26 units use an aluminized steel primary and stainless steel secondary heat exchanger assembly. Table 7 shows how many heat exchanger clamshells are used per unit. Heat is transferred to the air stream from all surfaces of the heat exchanger. The shape of the heat exchanger ensures maximum efficiency.

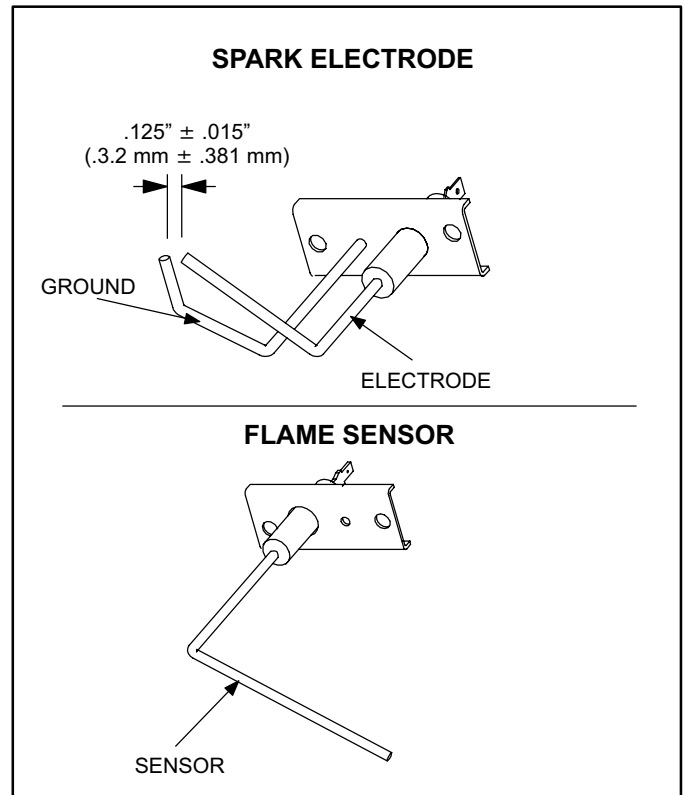

FIGURE 18

The combustion air blower pulls fresh air through the air intake box. This air is mixed with gas in the burner venturi and at the corbel orifices. The gas / air mixture is then burned at the entrance of each clamshell. Combustion gases are then pulled through the primary and secondary heat exchangers and exhausted out the exhaust vent pipe.

8-Flame Rollout Switch (S47)

Flame rollout switch S47 is a SPST N.C. high temperature limit located behind the burner air intake fitting on the burner box assembly (see figure 19). S47 is wired to the burner ignition control A3. When S47 senses flame rollout (indicating a blockage in the combustion air passages), the flame rollout switch trips, and the ignition control immediately closes the gas valve.

Switch S47 in all GHR26 units is factory preset to open at $320^{\circ}\text{F} \pm 12^{\circ}\text{F}$ ($160^{\circ}\text{C} \pm 6.7^{\circ}\text{C}$) on a temperature rise. All flame rollout switches are manually reset.

FLAME ROLLOUT SWITCH (S47)

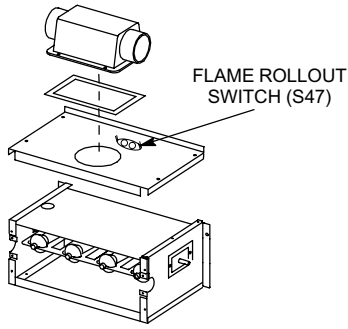

FIGURE 19

9-Gas Valve (GV1)

The GHR26 uses a gas valve manufactured by Honeywell or White Rodgers. The valves are internally redundant to assure safety shut-off. If the gas valve must be replaced, the same type valve must be used.

24VAC terminals and gas control knob are located on top of the valve. All terminals on the gas valve are connected to wires from the ignition control. 24V applied to the "MV" terminals on the Honeywell or (M1) terminals on the White Rodgers opens the main valve.

Inlet and outlet pressure taps are located on the valve. A regulator adjustment screw (figure 20 and 21) is located on the valve.

An LPG changeover kit is available. The kit includes burner orifices and a regulator conversion kit.

100% Sealed Combustion

The burner box is completely sealed and operates under a negative pressure. A pressure hose is connected from the burner box to the gas valve regulator. The gas valve senses the pressure in the burner box and changes gas valve outlet (manifold) pressure based on changes in burner box pressure. The intent is to compensate for different vent configurations which can greatly affect the rate of the unit.

GHR26 GAS VALVES

HONEYWELL VR8205 DIRECT SPARK GAS VALVE

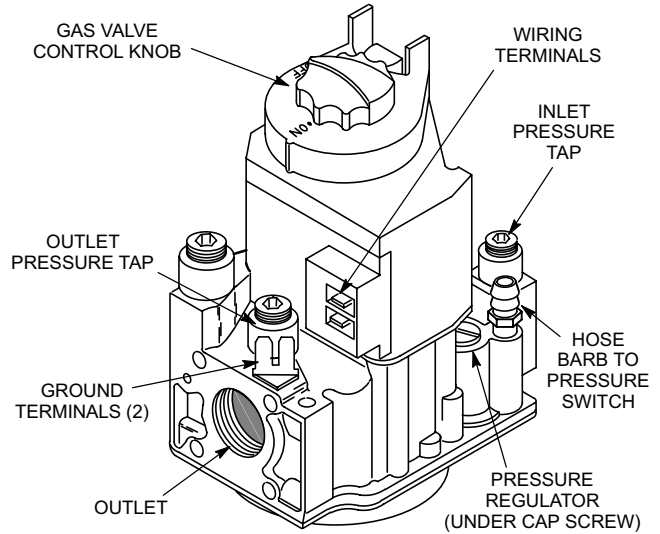

WHITE RODGERS 36E GAS VALVE REGULATOR ADJUSTMENT SCREW LOCATION

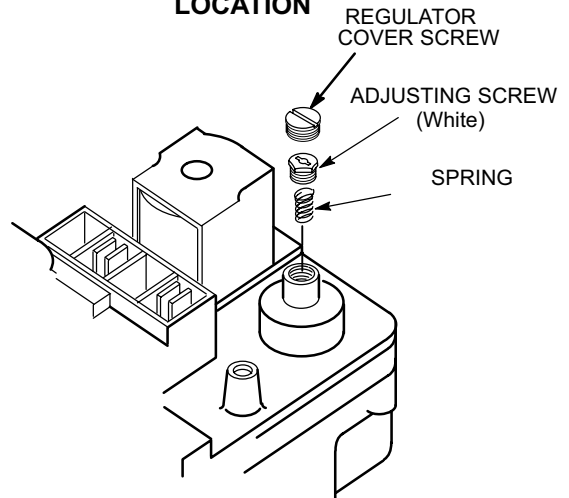

TYPICAL ACCESS TO REGULATOR FOR ADJUSTMENT AND L.P. CHANGEOVER

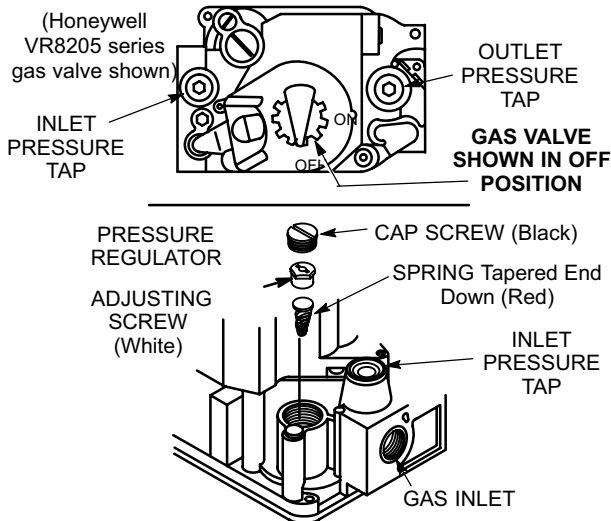

FIGURE 20

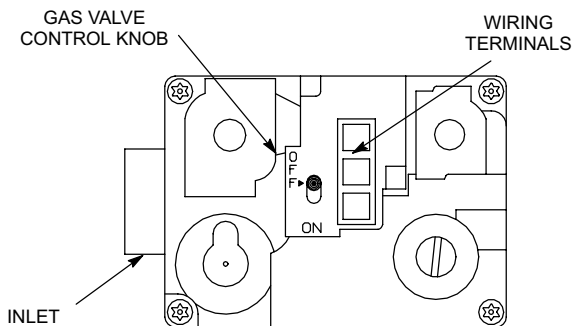

FIGURE 21

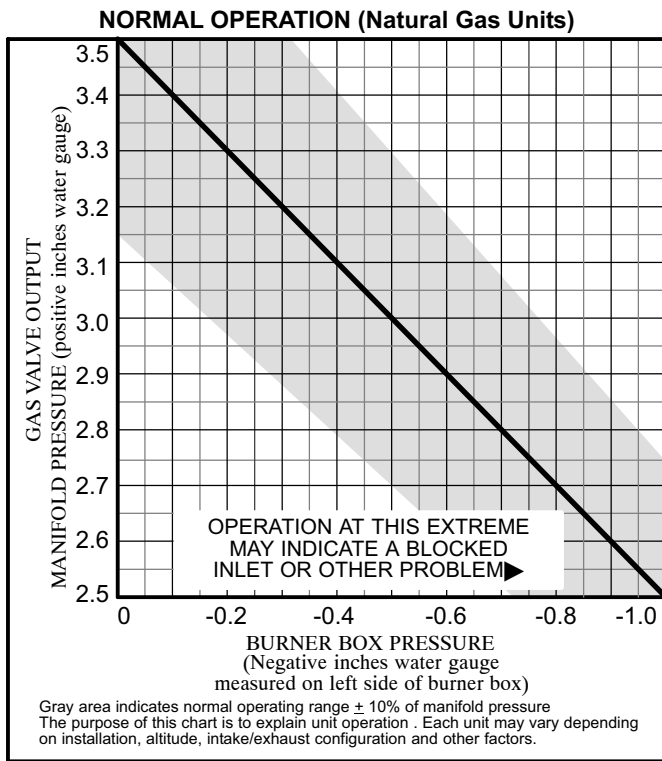

FIGURE 22

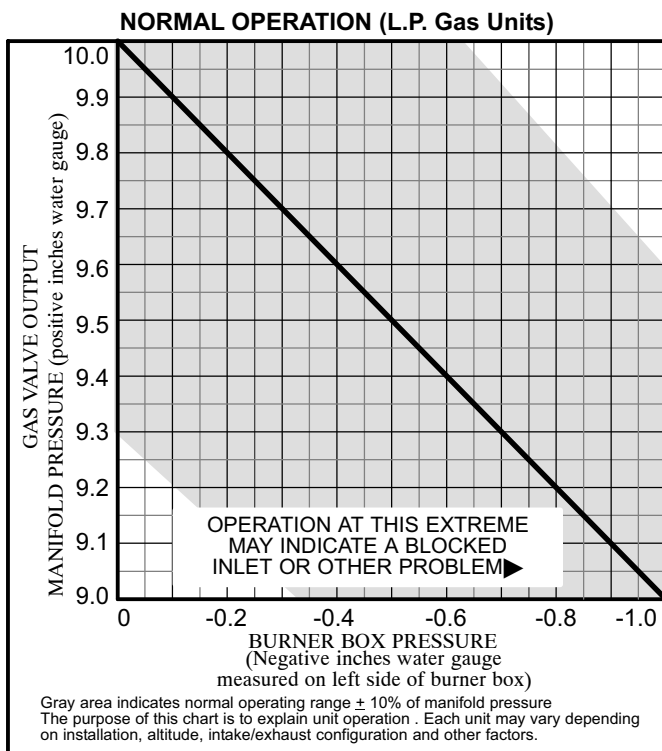

FIGURE 23

Figures 22 and 23 show how gas valve manifold pressure changes as burner box pressure changes. The GHR26 is a self adjusting unit to maintain a constant output. See section IV Heating System Service Checks, for a procedure showing how to check manifold pressure.

10-Combustion Air Prove Switch (S18)

GHR26 series units are equipped with a differential pressure switch located on either side of the heating compartment cabinet (factory installed on left side). The switch monitors the differential pressure between the downstream and upstream flue gas pressures. When the unit is installed for horizontal right-hand discharge, the air proving pressure switch must be moved to the opposite side of the unit. Any one of four different switches may be on the unit. One is manufactured by MPL. The other three switches are manufactured by TRIDELTA / HONEYWELL. Each switch operates the same and can be replaced with one another. See figure 24 for combustion air prove switch replacement. **Hoses must be connected to correct taps for switch to operate safely and properly.** GHR26-6 and -7 model units have color coded tubing to designate positive and negative sides of the pressure switch. Red square tubing should always be connected to the positive side of the pressure switch. Gray or black round tubing should always be connected to the negative side of the pressure switch. See figure 24.

The switch is a SPST N.O. pressure switch electrically connected to the integrated control. The purpose of the switch is to prevent burner operation if the combustion air blower is not moving enough air for proper combustion.

On start-up, the switch senses that the combustion air blower is operating. It closes a circuit to the ignition control when the difference in pressure across the pressure switch exceeds 0.90" W.C. (223.78Pa). If the switch does not successfully sense the required differential, the switch cannot close and the furnace cannot operate. The switch is factory set and is not adjustable. If the flue or air inlet become obstructed during operation, the switch senses a loss of pressure differential and opens the circuit to the ignition control. If the condensate line is blocked, water will back up into the header box and reduce the pressure differential across the switch. The pressure switch will open if the differential drops below 0.75" W.C. ± 05 " W.C. (186.48 Pa \pm 12.4 Pa).

To troubleshoot the pressure switch, temporarily jumper the switch. The unit will not fire with pressure switch jumpered. Therefore, the pressure switch must be bypassed after the combustion air blower is activated. This will determine if the pressure switch and furnace are operating properly. However, this may not indicate if the sealed combustion system is operating properly. If the unit cannot attain 0.75" W.C. (186.48 Pa) differential, the unit will not operate.

NOTE-Unit will not operate with pressure switch bypassed upon start-up. To troubleshoot pressure switch, jumper pressure switch following activation of combustion air blower.

Checks of pressure differential can aid in troubleshooting. When measuring the pressure differential, readings should be taken at the pressure switch. Lack of differential usually indicates problems in the intake or exhaust piping, but may indicate problems in the heat exchanger, condensing coil, header boxes, combustion blower or other components.

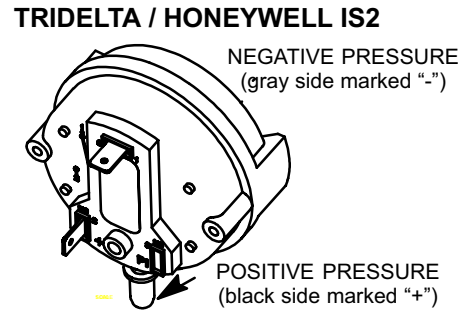
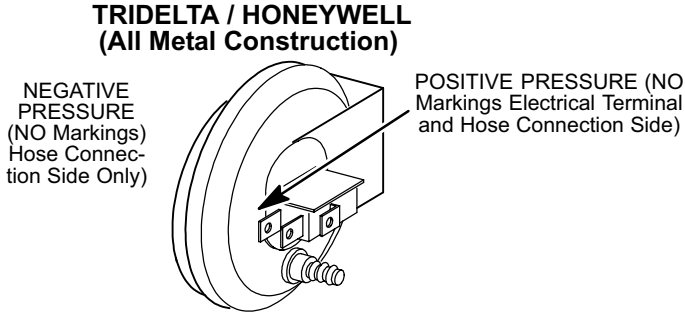
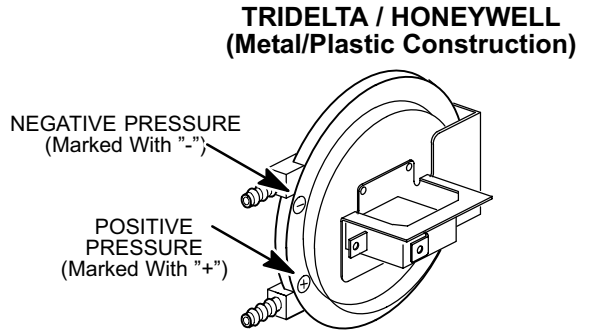
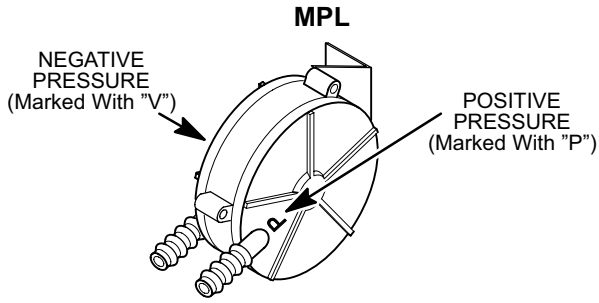

HORIZONTAL LEFT HAND AIR DISCHARGE

Connect hose (red square) to POSITIVE side on pressure switch and open tap on FRONT of collector box.

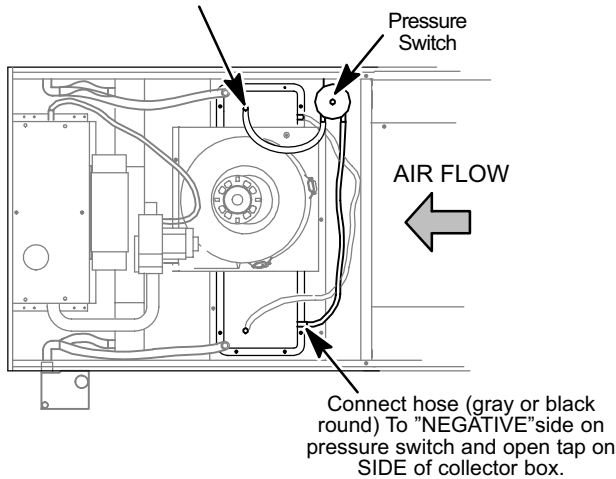

DOWN FLOW AIR DISCHARGE

Connect hose (gray or black round) To NEGATIVE side on pressure switch and open tap on FRONT of collector box.

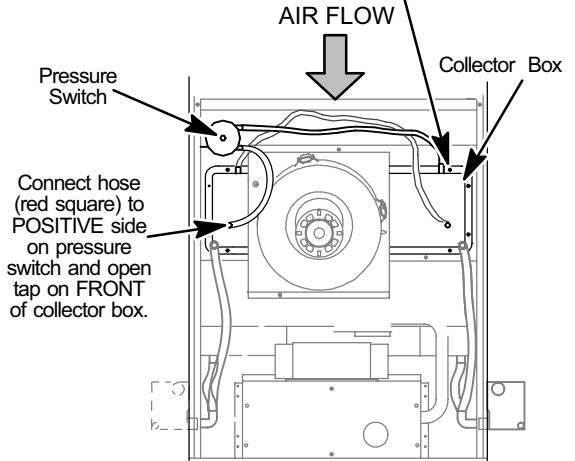

HORIZONTAL RIGHT HAND DISCHARGE

Connect the red square hose to the POSITIVE side on pressure switch and the open tap on the FRONT of the collector box.

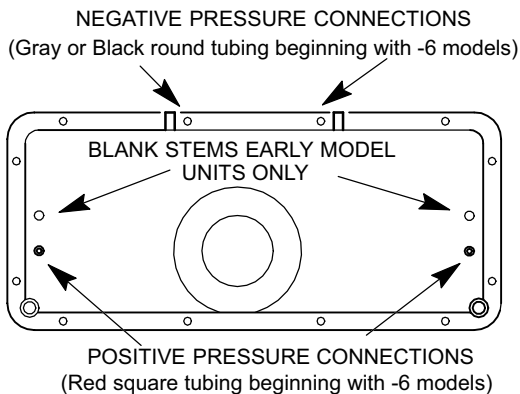
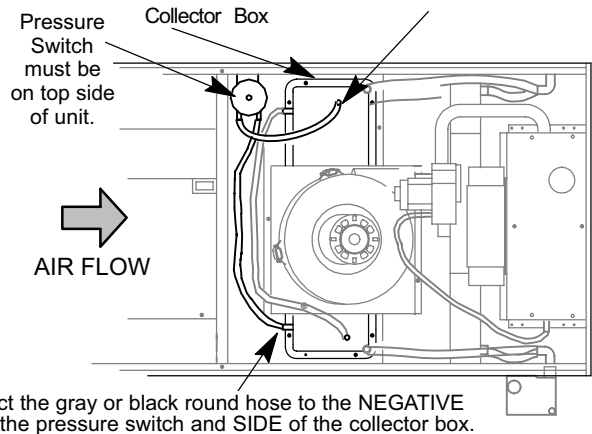

FIGURE 24

Measuring pressure differential

The differential pressure is the difference in pressure measured on either side of the pressure switch:

- 1 - Remove thermostat demand and allow unit to cycle off.
- 2 - Disconnect hose from front of pressure switch and install tee as shown in figure 25. Repeat sequence for hose connected to back of switch.

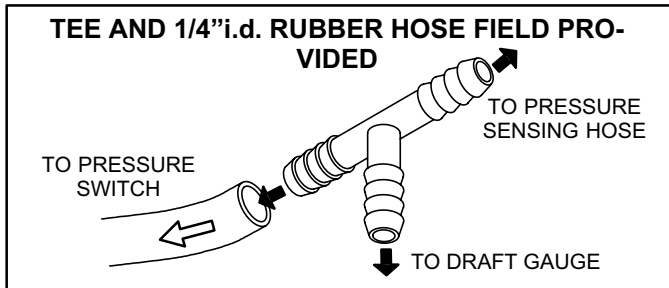

FIGURE 25

- 3 - Install manometer (draft gauge) to open ends of tee's. The hose from the back side of the switch goes to the zero side of the gauge.
- 4 - Operate unit and observe draft gauge reading. *Readings will change as heat exchanger warms.*
 - a. Take one reading immediately after startup.
 - b. Take a second reading after unit has reached steady state (approximately 5 minutes).

Pressure differential should be greater than .75" W.C. (186.48 Pa).

- 5 - Remove thermostat demand and allow to cycle off.
- 6 - Remove draft gauge and Tee's. Reinstall combustion air sensing hoses to the pressure switch.

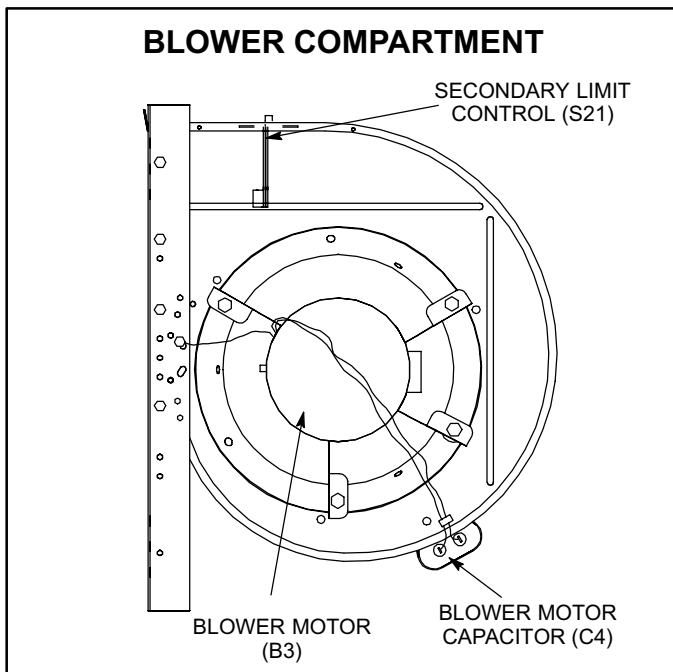

FIGURE 26

D-Blower Compartment (Figure 26)

Blower motor (B3), capacitor (C4), and secondary limit control (S21) are located in the blower compartment. The blower compartment can be accessed by removing the blower access panel.

1-Blower Motor (B3) and Capacitor (C4)

All GHR26 units use single phase direct drive blower motors. All motors are 120V permanent split capacitor motors to ensure maximum efficiency. See table 8 for horsepower and capacitor ratings.

TABLE 8

GHR26 BLOWER RATINGS 120V 1PH		
BLOWER MOTOR	HP	CAP
GHR26Q2/3-50	1/3	5MFD 370V
GHR26Q3-75 & Q3/4-100	1/2	7.5MFD 370V
GHR26Q4/5-100 & -120	3/4	40MFD 370V

2-Secondary Limit Control (S21)

The secondary limit (S21) on GHR26 units is mounted on the back side of the blower housing. When excess heat is sensed in the blower compartment, the limit will open. If the limit is tripped, the furnace control energizes the supply air blower and closes the gas valve. The limit automatically resets when unit temperature returns to normal. The switch opens at $160^{\circ}\text{F} \pm 5^{\circ}\text{F}$ ($71.1^{\circ}\text{C} \pm 2.8^{\circ}\text{C}$) on a temperature rise and resets at $130^{\circ}\text{F} \pm 8^{\circ}\text{F}$ ($54.4^{\circ}\text{C} \pm 4.4^{\circ}\text{C}$) on a temperature fall. The switch is factory set and cannot be adjusted. The setpoint is printed on the face plate of the limit.

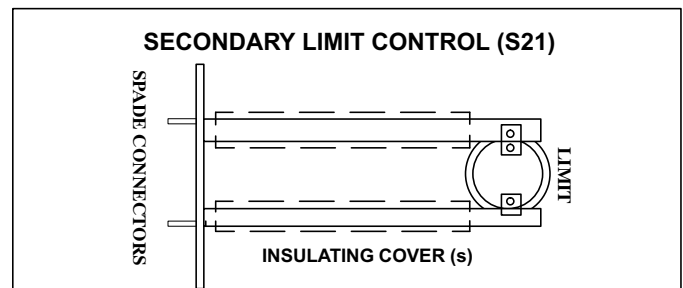

FIGURE 27

II-PLACEMENT AND INSTALLATION

Make sure unit is installed in accordance with installation instructions and applicable codes.

A-PVC Joint Cementing Procedure

⚠ WARNING

DANGER OF EXPLOSION! Fumes from PVC glue may ignite during system check. Remove spark plug wire from ignition control before 120V power is applied. Reconnect wire after two minutes.

- 1 - Measure and cut vent pipe to desired length.
- 2 - Debur and chamfer end of pipe, removing any ridges or rough edges. If end is not chamfered, edge of pipe may remove cement from fitting socket and result in a leaking joint.

- 3 - Clean and dry surfaces to be joined.
- 4 - Test fit joint and mark depth of fitting on outside of pipe.
- 5 - Uniformly apply liberal coat of PVC primer for PVC or ABS cleaner for ABS to inside socket surface of fitting and male end of pipe to depth of fitting socket.
- 6 - Promptly apply solvent cement to end of pipe and inside socket surface of fitting. Cement should be applied lightly but uniformly to inside of socket. Take care to keep excess cement out of socket. Apply second coat to end of pipe.

NOTE-Time is critical at this stage. Do not allow primer to dry before applying cement.

- 7 - Immediately after applying last coat of cement to pipe, and while both inside socket surface and end of pipe are wet with cement, forcefully insert end of pipe into socket until it bottoms out. Turn pipe 1/4 turn during assembly (but not after pipe is fully inserted) to distribute cement evenly. Once joint is made, PVC may swell. Hold joint together until bonded (approximately 20 seconds).

NOTE-Assembly should be completed within 20 seconds after last application of cement. Hammer blows should not be used when inserting pipe.

- 8 - After assembly, wipe excess cement from pipe at end of fitting socket. A properly made joint will show a bead around its entire perimeter. Any gaps may indicate a defective assembly due to insufficient solvent.
- 9 - Handle joints carefully until completely set.

B-Venting Considerations

All GHR26 furnaces must be vented independently as shown in figure 29 and must not be connected to a common venting system. If a GHR26 furnace replaces a less efficient furnace which was vented with other gas appliances into a common vent, the size of the common vent pipe must be appropriate for gas appliances which remain connected. Without the heat of the original furnace flue products, the vent pipe is probably oversized for the single water heater or other appliance(s). The common vent should be checked for proper draw for all appliance(s) which remain connected.

Checks of Common Venting System for Other Gas Appliances (Water Heater, etc...)

- 1 - Unused openings in the common venting system must be sealed.

- 2 - The venting system should be visually checked for proper size and horizontal pitch. You should also check and determine that there is no blockage or restriction, leakage, corrosion and other deficiencies which could cause an unsafe condition.

- 3 - Close all building doors and windows and all doors between the space in which the appliances remaining connected to the common venting system are located and other spaces of the building. Turn on clothes dryers and any appliances not connected to the common venting system. Turn on any exhaust fans, such as range hoods and bathroom exhausts, so they will operate at maximum speed. Do not operate a summer exhaust fan. Close fireplace dampers.

- 4 - Follow the lighting instructions. Place the appliance being inspected in operation. Adjust thermostat so appliance will operate continuously.

- 5 - Test for spillage at the draft hood relief opening after 5 minutes of main burner operation. Use match or candle flame, or smoke from a cigarette or cigar.

- 6 - After it has been determined that each appliance remaining connected to the common venting system properly vents when tested as outlined above, return doors, windows, exhaust fans, fireplace dampers and any other gas-burning appliance to their previous condition of use.

- 7 - If improper venting is observed during any of the tests, the common venting system must be corrected. The common venting system should be resized to approach the minimum size as determined by using the appropriate tables in appendix G in the current standards of the National Fuel Gas Code in the U.S.A. or category 1 in the Natural Gas and Propane Installation Code in Canada.

GHR26 Intake and Exhaust Piping Considerations

If the GHR26 venting system must be altered or repaired, use the following as a guide. Intake and exhaust pipes may be routed either horizontally through an outside wall or vertically through the roof. In attic or closet installations, vertical termination through the roof is preferred. Figures 29 through 32 show typical terminations.

- 1 - Use only recommended piping materials for both intake and exhaust piping.
- 2 - Secure permanent joints gas tight using approved cement.

- 3 - Piping diameters should be determined according to length of pipe run. See minimum flue pipe size table located on page 4. Locate intake piping upwind (prevailing wind) from exhaust piping. To avoid recirculation of exhaust gas on roof terminations, end of exhaust pipe must be higher than intake pipe.

Exhaust and intake exits must be in same pressure zone. Do not exit one through the roof and one through the side. Also, do not exit the intake on one side and the exhaust on another side of the house or structure.

- 4 - Intake and exhaust pipes should be placed as close together as possible at termination end (refer to illustrations). Maximum separation is 3" (76mm) on roof terminations and 6" (152mm) on side wall terminations.

NOTE-If winter design temperature is below 32° F (0° C), exhaust piping must be insulated with 1/2" (13mm) Armaflex or equivalent when run through unheated space. Do not leave any surface area of exhaust pipe open to outside air; exterior exhaust pipe must be insulated with 1/2" (13mm) Armaflex or equivalent. In extreme cold climate areas, 3/4" (19mm) Armaflex or equivalent is recommended. Insulation on outside runs of exhaust pipe must be painted or wrapped to protect insulation from deterioration.

- 5 - Exhaust piping must terminate straight out or up as shown. On roof terminations, the intake piping should terminate straight down using two 90° elbows (See figure 29). In rooftop applications, a 2" X 1-1/2" (51mm X 38mm) reducer for 2" (51mm) venting, 3" x 2" (76mm X 51mm) reducer for 3" (76mm) venting must be used on exhaust piping at the point where it exits the structure to improve the velocity of exhaust and force flue products away from intake piping.

NOTE-Care must be taken to avoid recirculation of exhaust back into intake pipe.

- 6 - On side wall exits, exhaust piping should extend a maximum of 12" (395mm) beyond the outside wall. Intake piping should be as short as possible. See figure 31.
- 7 - Minimum separation distance between the end of the exhaust pipe and the end of the intake pipe is 8" (203mm).

- 8 - If intake and exhaust piping must be run up a side wall to position above snow accumulation or other obstructions, refer to figure 32 for proper piping method. Piping must be supported every 3 ft. (.91m) as shown in figure 28 and must be insulated. When exhaust and intake piping must run up an outside wall, the exhaust piping is reduced accordingly after the final elbow.

- 9 - Position termination ends so they are free from any obstructions and above snow accumulation level (where applicable). Termination ends must be a minimum of 12" (305mm) above grade level. Do not point into window wells, stairwells, alcoves, courtyard areas or other recessed areas. Do not position termination ends directly below roof eaves.

- 10- Suspend piping using hangers at a minimum of every 5 feet (1.52m) for schedule 40 PVC and every 3 feet (.91m) for ABS-DWV, PVC-DWV, SDR-21 PVC, and SDR-26 PVC piping. A suitable hanger can be fabricated by using metal or plastic strapping or a large wire tie. See figure 28.

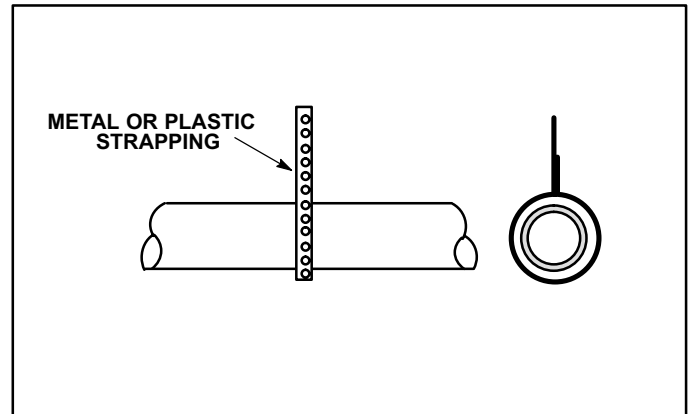

FIGURE 28

- 11- In areas where piping penetrates joists or interior walls, hole must be large enough to allow clearance on all sides of pipe through center of hole using support straps.

- 12- Isolate piping at the point where it exits the outside wall or roof.

- 13- Unit should not be installed in areas normally subject to freezing temperatures.

- 14- When furnace is installed in a residence where unit is shut down for an extended period of time, such as a vacation home, make provisions for draining exhaust tee, cold end header collector box, condensate collection trap and lines.

Intake Piping Requirements

Piping must be routed to outside of structure.

⚠ IMPORTANT

Combustion air intake inlet and exhaust outlet should not be located within 6 ft. (1.8m) of dryer vent or combustion air inlet or outlet of another appliance. Piping should not exit less than 3 ft. (.91m) from opening into another building.

ROOF TERMINATION

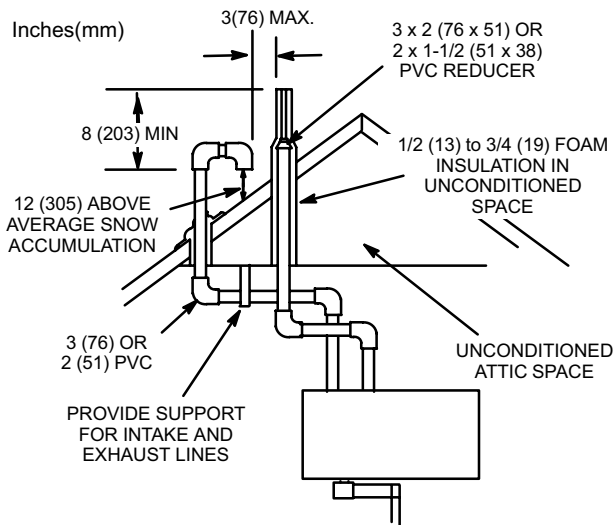

ROOF TERMINATION KIT
 (15F75) LB-49107CC for 2 (51) Venting
 (44J41) LB-65678A for 3 (76) Venting

FIGURE 29

CONCENTRIC ROOF/WALL TERMINATION KIT

(60G77) LB-49107CE -50 & -75 only
 (33K97) LB-87942 -100 & -120 only

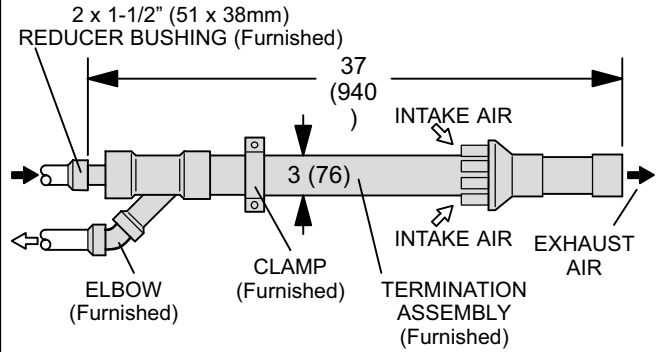

CONCENTRIC WALL TERMINATION APPLICATIONS

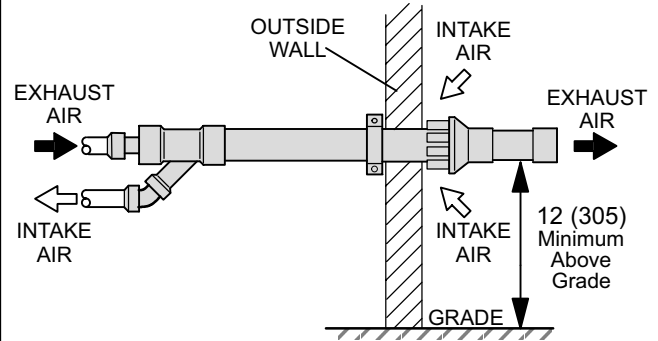

CONCENTRIC ROOF TERMINATION APPLICATIONS

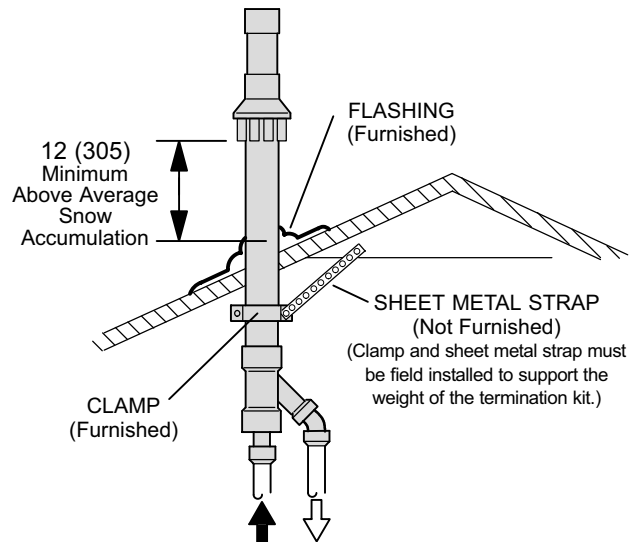

FIGURE 30

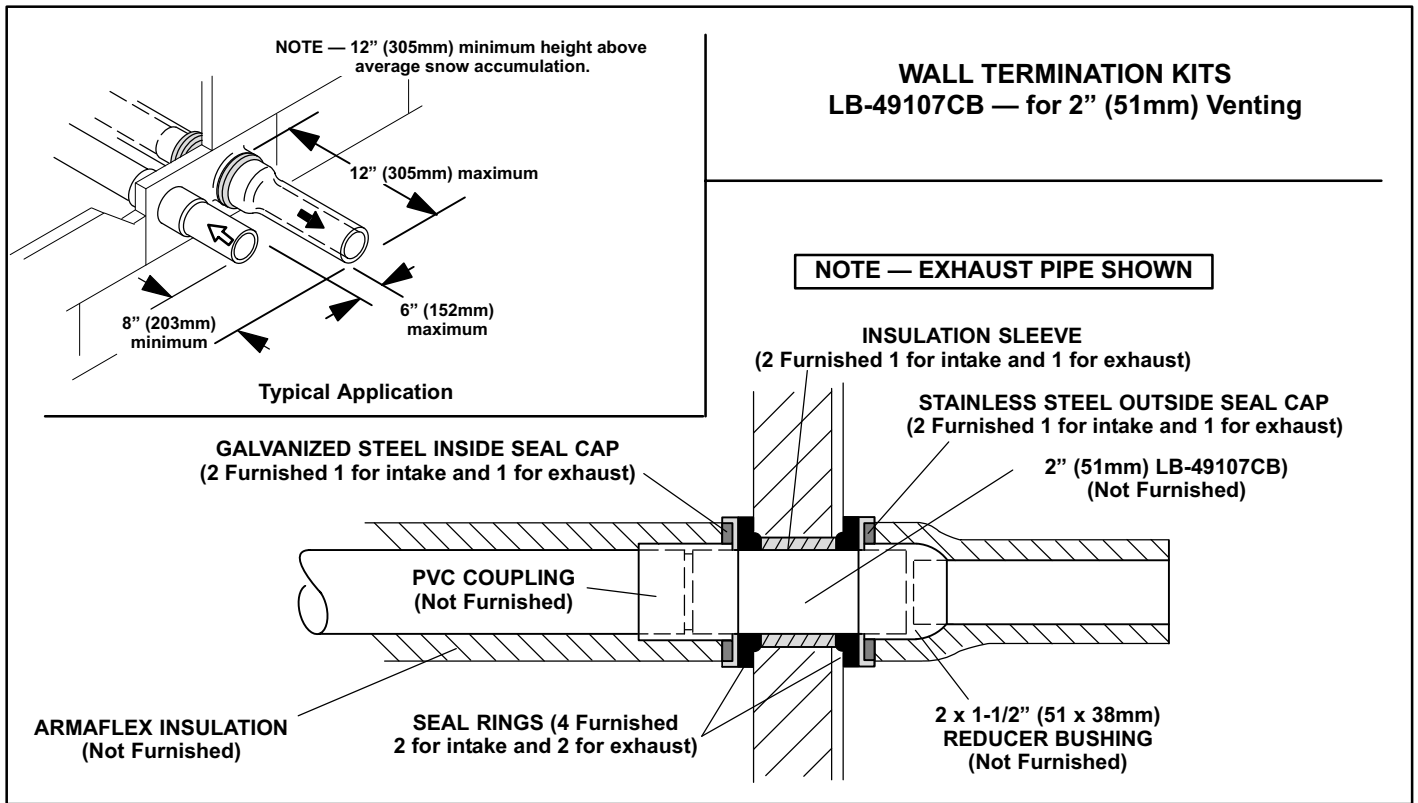

FIGURE 31

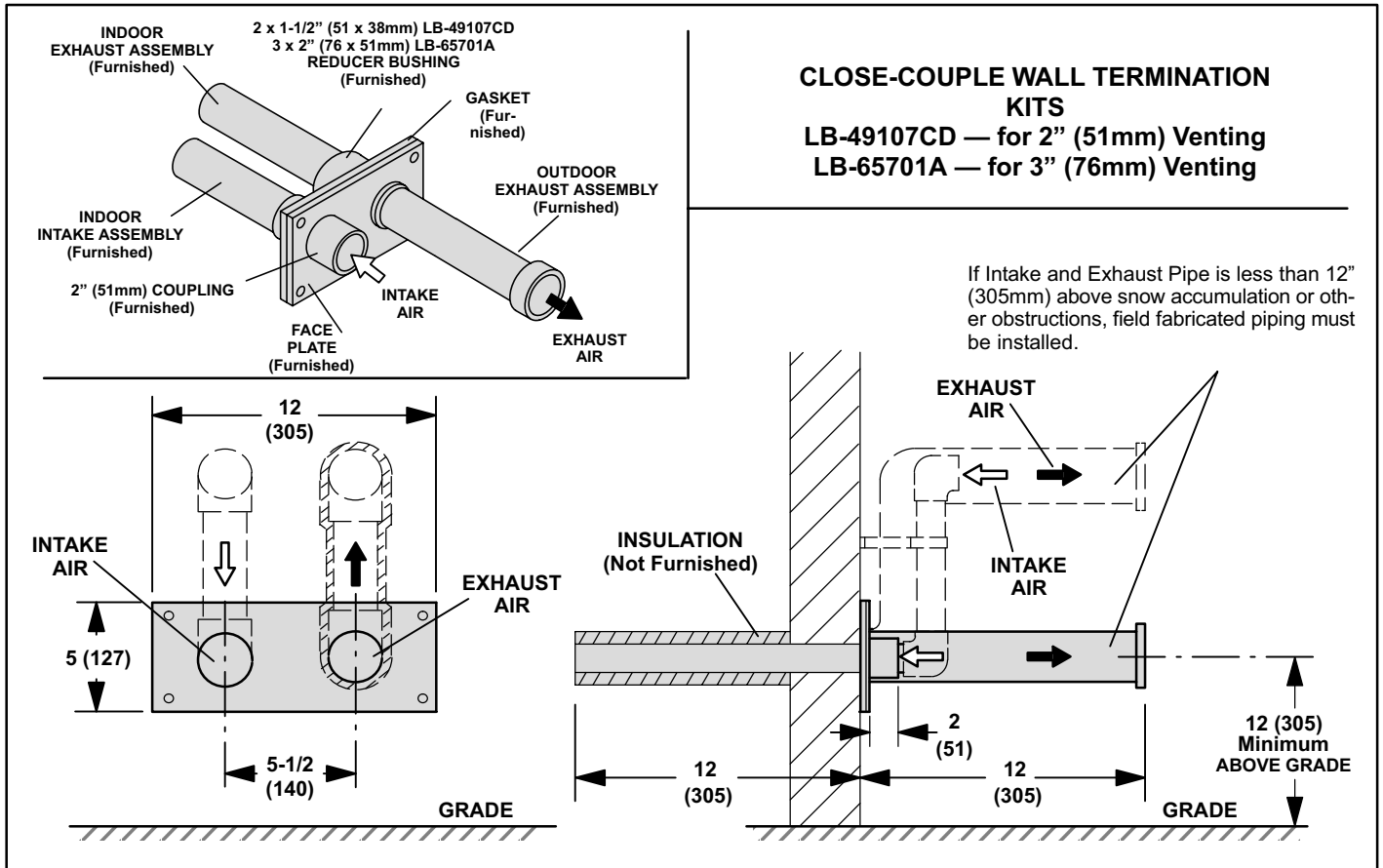

FIGURE 32

Exhaust Piping Requirements

This unit is designed for left or right air exhaust piping for the down-flow configuration. In horizontal applications, flue piping must exit the top side of the unit.

All horizontal runs of exhaust pipe must slope toward unit. A minimum of 1/4" (6mm) drop for every 12" (305mm) of horizontal run is mandatory for drainage. Horizontal runs of exhaust piping must be supported every 5 ft. (1.5m) [3 ft. (0.9m) for ABS and SDR] using hangers.

NOTE-Exhaust piping must be installed on the same side as the condensate trap.

NOTE-Exhaust piping should be checked carefully to make sure there are no sags or low spots.

⚠ CAUTION

Do not discharge exhaust into an existing stack or stack that also serves another gas appliance. If vertical discharge through an existing unused stack is required, insert PVC pipe inside the stack until the end is above the top or outlet end of the metal stack.

⚠ CAUTION

The exhaust vent pipe operates under positive pressure and must be completely sealed to prevent leakage of combustion products into the living space.

Condensate Piping Requirements

The GHR26 unit is designed for either left or right condensate plumbing in the down-flow configuration. In the horizontal position, trap should extend below unit; provide for a 3-3/4" (92mm) service clearance. Condensate drain line should be routed only within the conditioned space to avoid freezing of condensate and blockage of drain line. An electric heat cable should be used where condensate piping is exposed to unconditioned areas. If condensate piping needs to be relocated to another position or removed for service, use the following procedure to reinstall.

⚠ CAUTION

Do not use copper tubing or existing copper condensate lines for drain line.

- 1 - Determine the side the condensate trap is to be installed. Remove temporary plugs from condensate collar on which the condensate trap is to be installed.

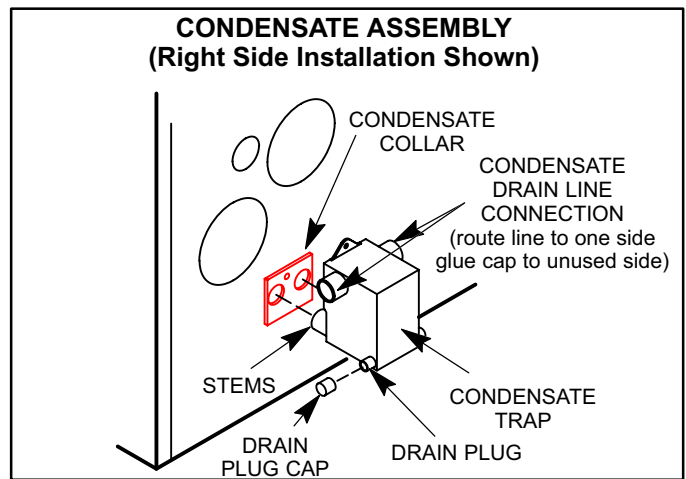

FIGURE 33

NOTE-Condensate trap must be installed on the same side as exhaust piping in downflow applications and on bottom of unit in horizontal applications.

- 2 - Apply glue to condensate trap stems and insert trap into holes provided in condensate collar. Make sure condensate trap is completely sealed to avoid any leaks. Use the provided 1/2" screw to secure the top of the condensate trap to the side of the unit. See figure 33.
- 3 - For downflow applications only, remove plugs from the unused condensate collar on the opposite side of the unit. Apply glue to the plugs and place them back into the condensate collar.
- 4 - Glue the drain line (field provided) to the trap. Route drain line to an open drain. Glue 1" (25mm) cap (provided on trap) on unused condensate drain line connection.
- 5 - Install a tee and vent pipe in the drain line near the trap. Top of vent pipe should be 7" (178mm) above drain level on trap.
- 6 - Condensate line must be sloped downward away from trap (a minimum of 1/4" [6mm] drop for each 12" [305mm] of horizontal line) to drain. If drain level is above condensate trap, condensate pump must be used in condensate line.

III-START-UP

A-Preliminary and Seasonal Checks

- 1 - Inspect electrical wiring, both field and factory installed for loose connections. Tighten as required.
- 2 - Check voltage at disconnect switch. Voltage must be within range listed on the nameplate. If not, consult the power company and have voltage condition corrected before starting unit.
- 3 - Inspect condition of condensate traps and drain assembly. Disassemble and clean seasonally.

B-Heating Start-Up

FOR YOUR SAFETY READ BEFORE LIGHTING

⚠ WARNING

Do not use this furnace if any part has been under-water. Inspect the furnace and replace any part of the control system and any gas control which has been under water.

⚠ WARNING

If overheating occurs or if gas supply fails to shut off, shut off the manual gas valve to the appliance before shutting off electrical supply.

⚠ CAUTION

Before attempting to perform any service or maintenance, turn the electrical power to unit OFF at disconnect switch.

BEFORE LIGHTING smell all around the appliance area for gas. Be sure to smell next to the floor because some gas is heavier than air and will settle on the floor.

Use only your hand to push in or turn the gas control knob. Never use tools. If the knob will not push in or turn by hand, do not force. Force or attempted repair may result in a fire or explosion.

GHR26 units are equipped with a hot surface or a direct spark ignition system. Do not attempt to manually light burners on these furnaces. Each time thermostat calls for heat, the burners will be automatically lit.

How To Operate Gas Valve (Figure 34)

⚠ WARNING

If you do not follow these instructions exactly, a fire or explosion may result causing property damage, personal injury or loss of life.

- 1 - **STOP!** Read the safety information at the beginning of this section.
- 2 - Set thermostat to lowest setting.
- 3 - Turn off all electrical power to furnace.
- 4 - This appliance is equipped with an ignition device which automatically lights the burner. Do **not** try to light the burner by hand.
- 5 - Remove unit access panel.
- 6 - On Honeywell VR8205 gas valves, turn knob on gas valve clockwise  to **OFF**. For White Rodgers 36E gas valves, move switch to **OFF**. Do not force. See figure 34.

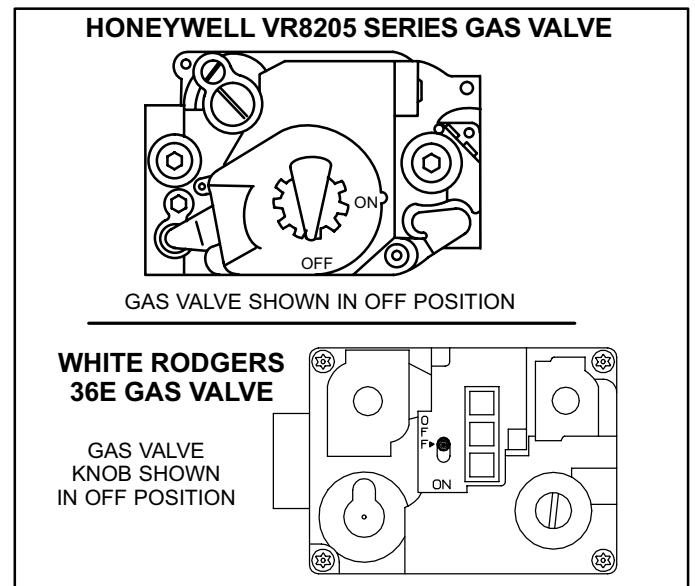



FIGURE 34

- 7 - Wait five (5) minutes to clear out any gas. If you then smell gas, **STOP!** Immediately call your gas supplier from a neighbor's phone. Follow the gas supplier's instructions. If you do not smell gas go to next step.
- 8 - For Honeywell VR8205 gas valves, turn knob on valve counterclockwise  to **ON**. For White Rodgers 36E gas valves, move switch to **ON**.
- 9 - Replace unit access panel.
- 10- Turn on all electrical power to unit.
- 11- Set thermostat to desired setting.

NOTE-On initial start-ups and when condensate trap is dry, unit may turn itself off and on to allow condensate trap to fill. This is normal operation.

- 12- If the furnace will not operate, follow the instructions "To Turn Off Gas To Unit" and call your service technician or gas supplier.

To Turn Off Gas To Unit

- 1 - Set thermostat to lowest setting.
- 2 - Turn off all electrical power to unit if service is to be performed.
- 3 - Remove heat section access panel.
- 4 - On Honeywell VR8205 gas valves, turn knob on gas valve clockwise  to **OFF**. For White Rodgers 36E gas valves, move switch to **OFF**. Do not force.
- 5 - Replace unit access panel.

C-Safety or Emergency Shutdown

Turn off unit power. Close manual and main gas valves.

D-Extended Period Shutdown

Turn off thermostat or set to "UNOCCUPIED" mode. Close all gas valves (both internal and external to unit) to guarantee no gas leak into combustion chamber. Turn off power to unit. All access panels, covers and vent caps must be in place and secured.

Refer to "Maintenance" section of this manual for instructions on how to prepare condensate assembly for extended period shutdown.

IV-HEATING SYSTEM SERVICE CHECKS

A-A.GA./C.GA. Certification

All units are A.G.A. and C.G.A. design certified without modifications. Refer to the GHR26 Operation and Installation Instruction Manual Information.

B-Gas Piping

Gas supply piping should not allow more than 0.5"W.C. drop in pressure between gas meter and unit. Supply gas pipe must not be smaller than unit gas connection.

Compounds used on gas piping threaded joints should be resistant to action of liquefied petroleum gases.

C-Testing Gas Piping

When pressure testing gas lines, the gas valve must be disconnected and isolated. Gas valves can be damaged if subjected to more than 0.5psig (14" W.C.). See figure 35. If the pressure is equal to or less than 0.5psig (14"W.C.), use the manual shut-off valve before pressure testing to isolate furnace from gas supply.

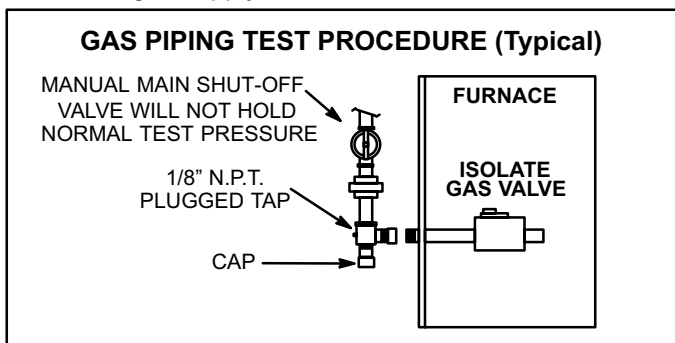

FIGURE 35

⚠ IMPORTANT

In case emergency shutdown is required, turn off the main shut-off valve and disconnect the main power to unit. These controls should be properly labeled by the installer.

When checking piping connections for gas leaks, use preferred means. Kitchen detergents can cause harmful corrosion on various metals used in gas piping. Use of a specialty Gas Leak Detector is strongly recommended. It is available through Lennox under part number 31B2001. Do not use matches, candles, flame or any other source of ignition to check for gas leaks.

D-Testing Gas Supply Pressure

When testing supply gas pressure, connect test gauge to inlet pressure tap (field provided). See figure 35. Check gas line pressure with unit firing at maximum rate. Low pressure may result in erratic operation or underfire. High pressure can result in permanent damage to gas valve or overfire. For natural gas units, operating pressure at unit gas connection must be a minimum of 4.5" W.C. (1.12kPa). For L.P. gas units, operating pressure at unit gas connection must be a minimum of 11.0" W.C. (2.74kPa). For both natural and L.P. gas units, operating pressure must not exceed 13" W.C. (3.23 kPa).

On multiple unit installations, each unit should be checked separately, with and without the other units operating. Supply pressure minimum and maximum must be the same as listed in previous paragraph.

E-Check Manifold Pressure

Manifold *Operating* Pressure is the manifold pressure measured during normal operation (sensing burner box pressure). Manifold *Absolute* Pressure is manifold pressure measured when the gas valve regulator is operating at factory preset level (sensing atmospheric pressure). After line pressure has been checked and adjusted, check manifold absolute pressure. Move pressure gauge to outlet pressure tap located on unit gas valve (GV1). Checks of manifold absolute pressure are made as verification of proper regulator adjustment.

Manifold operating pressure for the GHR26 can be measured at any time the gas valve is open and is supplying gas to the unit. Normal manifold operating pressure for natural gas units is 2.5 to 3.5" W.C. (621 to 870 Pa). See figure 22. For LP/propane gas the correct manifold operating pressure is 9.0 to 10.0" W.C. (2.24 to 2.49 Pa). See figure 23.

⚠ IMPORTANT

For safety, connect a shut-off valve between the manometer and the gas tap to permit shut off of gas pressure to the manometer.

TABLE 9
GAS VALVE REGULATION*

Unit (Fuel)	Absolute Pressure (outlet) in. W.C.
Natural	3.5
L.P	10.0

The gas valve is factory set and should not require adjustment. See table 9. Also, gas valve regulation varies with burner box pressure (figures 22 and 23).

*Manifold Absolute Pressure Measurement and Adjustment

- 1 - Connect test gauge to outlet tap on gas valve.
- 2 - Disconnect pressure sensing hose from gas valve and plug hose by covering opening with tape or equivalent. Leave hose barb on valve open to atmosphere.
- 3 - Start unit and allow 5 minutes for unit to reach steady state.
- 4 - While waiting for the unit to stabilize, notice the flame. Flame should be stable and should not lift from burner. Natural gas should burn blue. L.P. gas should burn mostly blue with some orange streaks.
- 5 - After allowing unit to stabilize for 5 minutes, record manifold pressure and compare to values given in table 9. If values are different, adjust to table 9.

NOTE-Shut unit off and remove manometer as soon as an accurate reading has been obtained. Take care to replace pressure tap plug.

NOTE-During this test procedure, the unit will be overfiring:

- Operate unit only long enough to obtain accurate reading to prevent overheating heat exchanger.
 - Attempts to clock gas valve during this procedure will be inaccurate. Measure gas flow rate only during normal unit operation.
- 6 - When test is complete remove obstruction from hose and return hose to gas valve barb.

F- Proper Gas Flow

Furnace should operate at least 5 minutes before checking gas flow. Determine time in seconds for **two** revolutions of gas through the meter. (Two revolutions assures a more accurate time.) Divide by two and compare to time in table 10 below. Adjust manifold pressure on gas valve to match time needed.

NOTE- To obtain accurate reading, shut off all other gas appliances connected to meter.

TABLE 10

GAS METER CLOCKING CHART				
GHR26 Unit	Seconds for One Revolution			
	Natural		LP	
	1 cu ft Dial	2 cu ft Dial	1 cu ft Dial	2 cu ft DIAL
-50	72	144	180	360
-75	48	96	120	240
-100	36	72	90	180
-120	30	60	75	150
Natural-1000 btu/cu ft		LP-2500 btu/cu ft		

NOTE- To obtain accurate reading, shut off all other gas appliances connected to meter.

G-High Altitude Derate

Units are self-compensating for altitude and do not require kits or adjustment when installed below 7500 feet (2286m) elevation. See table 9 for correct manifold pressures. If unit is installed at an altitude higher than 7500 feet (2286m), refer to local codes.

H-Flame Signal

A 20 microamp DC meter is needed to check the flame signal on the ignition control.

Flame (microamp) signal is an electrical current which passes from the furnace control through the sensor during unit operation. Current passes from the sensor through the flame to ground to complete a safety circuit.

To Measure Flame Signal - Ignition Control:

A transducer (Part #78H5401 available from Lennox Repair Parts) is required to measure flame signal. See figure 36. The transducer converts microamps to volts on a 1:1 conversion. The EGC-1 control flame signal should be 1.0 - 3.5 nominal microamps, therefore a reading of 1.0 - 3.5 nominal volts should be read on the meter. A digital readout meter must be used. The Sunlight control should read 0.7 or more microamps. See sensor section in this manual for more information. The transducer plugs into most meters. See figure 37 for proper use of transducer.

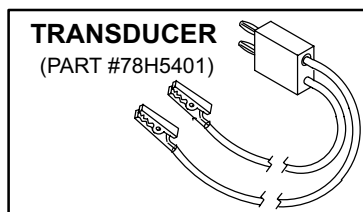

FIGURE 36

- 1 - Set the volt meter to the DC voltage scale. Insert transducer into the VDC and common inputs. Observe correct polarities. Failure to do so results in negative (-) values.
 - 2 - Turn off supply voltage to control.
 - 3 - Take burner box cover off.
 - 4 - Disconnect ignition control flame sensor wire from the flame sensor.
 - 5 - Pull flame sensor wire out of the burner box and replace with the (-) lead of the transducer.
- NOTE-The grommet will come out with the flame sensor wire. Take care not to lose the grommet.*
- 6 - Connect (-) lead of the transducer to flame sensor.
 - 7 - Connect (+) lead of transducer to the ignition control sensor wire.
 - 8 - Put burner box cover back on.
 - 9 - Turn supply voltage on and close thermostat contacts to cycle system.
 - 10- When main burners are in operation for two minutes, take reading. Remember 1 DC volt = 1 DC microamp.
 - 11- When the test is finished, remove burner box cover.
 - 12- Remove both the (-) and (+) leads of the transducer. Replace the flame sensor wire through the hole, making sure the grommet is in place, and reconnect to the flame sensor.
 - 13- Put burner box cover back on.

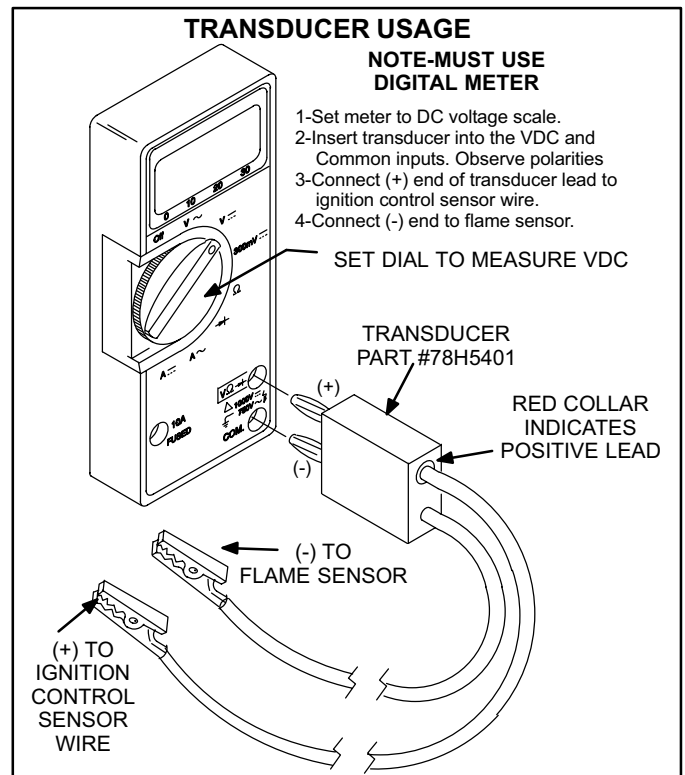

FIGURE 37

⚠ WARNING

Fire and explosion hazard.
These instructions MUST be followed exactly.
Can cause a fire or explosion resulting in property damage, personal injury or loss of life.

V-TYPICAL OPERATING CHARACTERISTICS

A-Blower Operation and Adjustment

NOTE- The following is a generalized procedure and does not apply to all thermostat controls.

- 1 - Blower operation is dependent on thermostat control system.
- 2 - Generally, blower operation is set at thermostat subbase fan switch. With fan switch in ON position, blower operates continuously. With fan switch in AUTO position, blower cycles with demand.
- 3 - In all cases, blower and entire unit will be off when the system switch is in OFF position.

B-Temperature Rise

Temperature rise for GHR26 units depends on unit input, blower speed, blower horsepower and static pressure as marked on the unit rating plate. The blower speed must be set for unit operation within the range of "AIR TEMP. RISE °F" listed on the unit rating plate.

To Measure Temperature Rise:

- 1 - Place plenum thermometers in the supply and return air plenums. Locate supply air thermometer in the first horizontal run of the plenum where it will not pick up radiant heat from the heat exchanger.

- 2 - Set thermostat to highest setting.
- 3 - After plenum thermometers have reached their highest and steadiest readings, subtract the two readings. The difference should be in the range listed on the unit rating plate. If the temperature is too low, decrease blower speed. If temperature is too high, first check the firing rate. Provided the firing rate is acceptable, increase blower speed to reduce temperature. To change blower speed taps see the Blower Speed Taps section in this manual.

C-External Static Pressure

- 1 - Measure tap locations as shown in figure 38.

- 2 - Punch a 1/4" diameter hole in supply and return air plenums. Insert manometer hose flush with inside edge of hole or insulation. Seal around the hose with perma-gum. Connect the zero end of the manometer to the discharge (supply) side of the system.

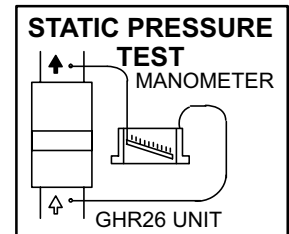

FIGURE 38

- On ducted systems, connect the other end of manometer to the return duct as above. For systems with non-ducted returns, leave the other end of the manometer open to the atmosphere.
- 3 - With only the blower motor running and the evaporator coil dry, observe the manometer reading. Adjust blower motor speed to deliver the air desired according to the job requirements.
- 4 - Pressure drop must not exceed 0.5" W.C.
- 5 - Seal around the hole when the check is complete.

D-Blower Speed Taps Leadless Motors

-1, -2 and -3 Models

Blower speed tap selection is accomplished by changing the taps at the blower motor harness connector. Disconnect harness connector from motor to expose speed selectors. Blower speed selections are listed in table 11.

To Change Blower Speed

- 1 - Turn off electric power to furnace.
- 2 - Remove blower access door.
- 3 - Disconnect blower motor harness from motor.
- 4 - Select desired speeds for heating and cooling. See table 11.
- 5 - Depress harness connector tab to release wire terminal. Select connector location for new speed (refer to unit wiring diagram). Insert wire terminal until it is securely in place. See figure 39.
- 6 - Replace harness connector to motor.

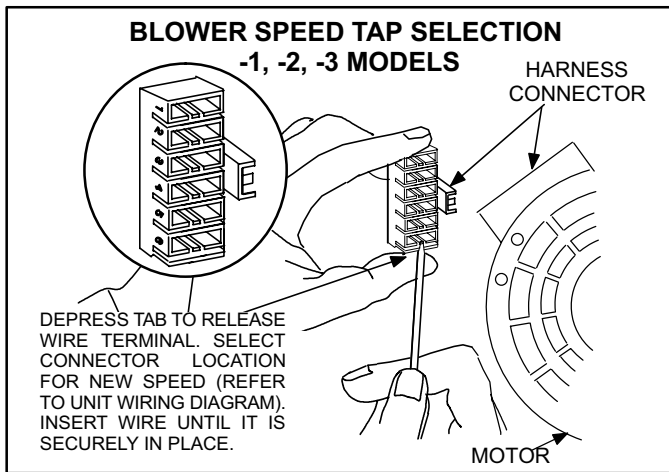

FIGURE 39

E-Blower Speed Taps Leaded Motors

-4 and -7 Models

Blower speed tap changes are made on the SureLight control board. See figure 12. Unused taps must be secured on dummy terminals "PARK M1" and or "PARK M2" on the SureLight board. The heating tap is connected to the "ACB HEAT" terminal and the cooling tap is connected to the "ACB COOL" terminal. The continuous blower tap is connected to the "ACB LOW" terminal.

To change existing heat tap, turn off power then switch out speed tap on "ACB HEAT" with tap connected to "PARK M1" or "PARK M2". See table 12 for blower motor tap colors for each speed.

TABLE 11

UNIT	BLOWER SPEED CHART			MOTOR SPEEDS AVAILABLE	
	FACTORY CONNECTED SPEED TAP				
	COOL	HEAT	CONT		
02-45/60	2	4	5	4	
03-60/75	2	4	5	4	
04-75, 3/4-100	2	4	5	5	
04/5-100/120	2	5	6	5	
02-75	2	3	5	4	
04/5-140, 3/4-120	2	3	6	5	
BLOWER SPEED SELECTION HI ← → LO					
SPEED TAP	2	3	4	5	4
	2	3	4	5	6

TABLE 12

UNIT	BLOWER SPEED CHART					MOTOR SPEEDS AVAILABLE
	FACTORY CONNECTED SPEED TAPS					
	COOL	HEAT	ACB LOW	M1	M2	
02/3-50		YELLOW	RED	----	BROWN	4
03-75		YELLOW	RED	----	BROWN	4
03/4-100		YELLOW	RED	----	BROWN	4
04/5-100	BLACK	YELLOW	RED	BROWN	BLUE	5
04/5-120		BLUE	RED	BROWN	YELLOW	5
HI ← BLOWER SPEED SELECTION → LO						
SPEED TAPS	BLACK	BROWN	YELLOW	RED		4
	BLACK	BROWN	BLUE	YELLOW	RED	5

GHR26 BLOWER REMOVAL

To Remove Blower:

- 1- Turn off line voltage power. Unplug the following jack/plugs: J96/P96 power interface, J135/P135 secondary limit, J58/P58 control, J98/P98 CAB, and J43/P43 blower motor.
- 2- Remove screws (2) and remove control box cover. Disconnect thermostat wiring connections by removing low voltage terminal strip. Disconnect spark wire and grommet.
- 3- Loosen screws (2) and remove control box from unit. Holes are slotted so screws do not need to be removed.
- 4- Remove bolts (2) and remove blower from unit.

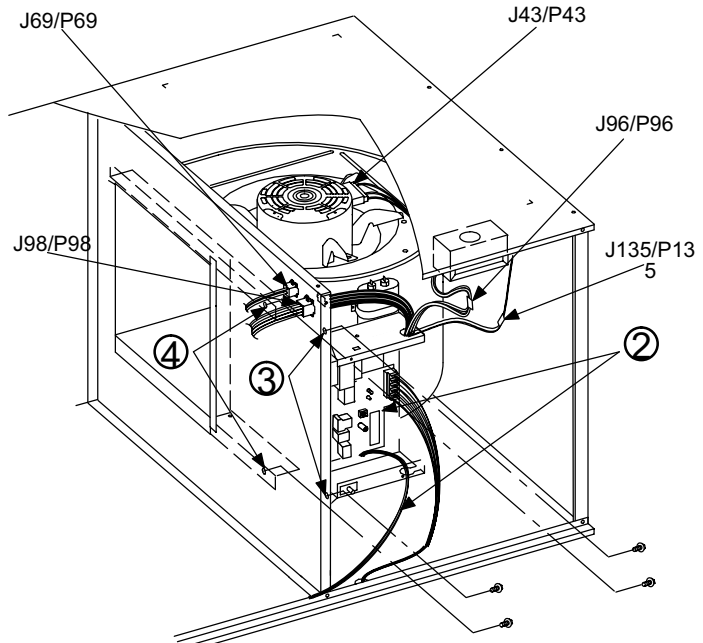

FIGURE 40

VI-MAINTENANCE

Retainers for factory supplied return air filter are shown in figure 41.

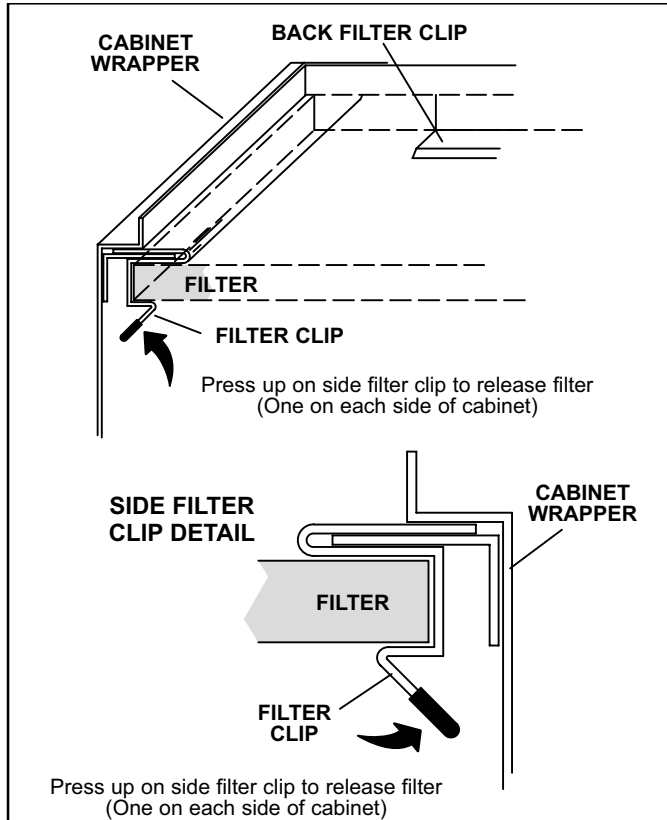

FIGURE 41

A-Filters

At the beginning of each heating season, the system should be checked as follows:

- 1 - Filters should be inspected monthly and must be cleaned or replaced when dirty to ensure proper furnace operation.
- 2 - Reusable foam filters used with the GHR26 can be washed with water and mild detergent. When dry, they should be sprayed with filter handicoater prior to reinstallation. Filter handicoater is RP Products coating no. 418 and is available as Lennox part no. P-8-5069.
- 3 - If replacement is necessary, order Lennox part no. 31J81 for 14 X 25 inch (356 X 635mm) filter for GHR26-50 and -75 units and P-8-7831 for 20 X 25 inch (508 X 635mm) filter for GHR26-100 and -120 units.

B-Cleaning Heat Exchanger and Burners

NOTE-Use papers or protective covering in front of furnace while cleaning furnace.

Cleaning the heat exchanger is not recommended; but, if it becomes necessary, follow the procedures outlined below and refer to figure 1 for parts arrangement. Pay close attention to wire routing and plumbing connections.

If at all possible, the unit should be removed and placed on its back. Tools needed are: slotted screwdriver, extra long 1/4" nut driver, extra long 5/16" nut driver, and duck-bill pliers.

Heat Exchanger

- 1 - Turn off electrical and gas power supplies to furnace.
- 2 - Remove upper and lower furnace access panels.
- 3 - Remove 3/8" rubber cap from condensate drain plug and drain. Replace cap after draining.
- 4 - Disconnect and remove intake pipe from air intake fitting.
- 5 - Mark all gas valve wires and disconnect them from valve.
- 6 - Remove gas supply line connected to gas valve. Disconnect gas valve sensing hose from side of burner box. Remove burner box cover by removing six (four on some units) securing screws. Remove gas valve/manifold assembly.
- 7 - Detach burner box from vestibule panel by removing four securing screws. Take care to avoid damaging the glass fiber gasket.
- 8 - Mark and disconnect spark and sensor electric wires from the ignitor and flame sensor.
- 9 - Disconnect wires from flame roll-out switch. Remove wires from patch plates. Remove side plates on burner box holding sensor and spark electrode. Set burner burner box assembly aside.

NOTE- If burner cleaning is needed, do so at this time. Refer to burner cleaning procedure.

- 10- Remove flexible exhaust tee by loosening three clamps.
- 11- Disconnect drain line attached to condensate trap. Remove screws that secure both condensate collars to either side of the unit and remove collars. It may be necessary to cut the pipe to allow for removal of the condensate trap. Remove drain tubes from cold end header collector box.
- 12- Disconnect condensate drain tubing from exhaust pipe. Remove screws that secure both flue collars into place. Remove flue collars. It may be necessary to cut the exiting exhaust pipe to allow for removal of the fittings.
- 13- Disconnect 2-pin plug from combustion air blower. Remove combustion air blower from bracket by removing four securing screws. Remove ground wire from bundle.
- 14- Remove combustion air blower bracket by removing two screws from collector box and two screws from vestibule panel.
- 15- Disconnect combustion air pressure and condensate sensing hoses from cold end header collector box. Remove pressure hose from two blank stems on cold end header collector box.

- 16- Mark and remove wires from pressure switch. Remove pressure switch/bracket assembly. Keep hoses attached to pressure switch. Remove pressure switch installation screws from both sides of the unit.
- 17- Disconnect 9-pin and 3-pin plugs at blower deck. Remove both plugs from the heat exchanger side of the blower deck.
- 18- Remove the primary limit from vestibule panel.
- 19- Remove two (2) screws from the front cabinet flange at the blower deck. Remove front screws from cabinet at blower deck on left and right sides. Cabinet sides must be slightly spread apart to clear heat exchanger passage.

NOTE-To protect insulation in horizontal applications, slide a piece of sheet metal between the coil section of the heat exchanger and the cabinet when removing and replacing heat exchanger. Remove indoor blower for horizontal installations. Remove sheet metal when complete.
- 20- Remove screws along vestibule sides and bottom which secure vestibule panel and heat exchanger assembly to cabinet.
- 21- With a pair of duck bills, carefully bend bottom flange straight. Use caution not to damage the cabinet. Remove heat exchanger.
- 22- Back wash heat exchanger with soapy water solution or steam. **If steam is used it must be below 275°F (135°C).**
- 23- Thoroughly rinse and drain the heat exchanger. Soap solution can be corrosive so take care that entire assembly is completely rinsed.
- 24- Re-install heat exchanger into cabinet (blower deck end first) making sure that the clamshells of the heat exchanger assembly are resting on the supports at the rear of the cabinet. This can be viewed by removing the indoor blower and examining through the blower opening.
- 25- Re-secure the supporting screws along the vestibule sides and bottom to the cabinet. Carefully bend bottom flange back to a 90 degree angle with a pair of duck bills. Once again, use caution not to damage the cabinet.
- 26- Re-install cabinet screws on sides and front flange at blower deck.
- 27- Re-install primary limit to vestibule panel.
- 28- Re-install 9-pin plug to blower deck and connect it to the 9-pin plug from below the blower deck. Re-install 3-pin plug to blower deck and connect it to the 3-pin plug from below the blower deck.
- 29- Re-install pressure switch/bracket assembly and replace pressure switch screws on both sides of unit from installed pressure switch. Reconnect wires to pressure switch.
- 30- Connect combustion air pressure and condensate sensing hoses from pressure switch to cold end header collector box. See figure 24 to confirm hose location.
- 31- Re-install the combustion air bracket.
- 32- Re-install the combustion air blower to bracket. Reconnect the 2-pin plug to the wire harness.
- 33- Replace flue collars with securing screws to either side of the unit. Reconnect exhaust piping and exhaust drain tubing.
- 34- Replace condensate collars with securing screws to either side of the unit. Reconnect drain line to condensate trap. Reconnect drain tubing from cold end header collector box. Reconnect condensate drain tubing from exhaust pipe.
- 35- Replace flexible exhaust tee to combustion air blower and exhaust pipes and secure with three clamps.
- 36- Align burner box gasket to securing holes closest to the end of the unit. Use a small piece of tape to secure gasket to vest panel. Make sure glass fiber gasket has not been damaged so it will provide a continuous seal between the burner box and the vestibule panel.
- 37- Move burner box assembly to vestibule area.
- 38- Reconnect flame roll-out switch wires. Re-install patch plates to side of burner box. Connect wires to patch plates.
- 39- Reconnect sensor and spark electrode or SureLight ignitor wires through provided openings in the burner plate.
- 40- Replace four screws to secure reassembled burner box assembly to vestibule panel. **Make sure burners line up in center of burner ports.**
- 41- Re-install gas valve manifold assembly. Replace burner box cover. Re-install gas supply line to gas valve. Attach gas valve pressure sensing hose to burner box.
- 42- Reconnect gas valve wires to gas valve.
- 43- Re-install intake vent pipe to rubber connector on intake fitting with hose clamp.
- 44- Replace both upper and lower access panels.
- 45- Refer to instruction on verifying gas and electrical connections when re-establishing supply.
- 46- Following lighting instructions, light and run unit for 5 minutes to ensure heat exchanger is clean, dry and operating safely.

Cleaning the Burner Assembly

- 1 - Turn off electrical and gas power supplies to furnace.
- 2 - Remove upper and lower furnace access panels.
- 3 - Disconnect and remove intake pipe from air intake fitting.
- 4 - Mark all gas valve wires and disconnect them from valve.
- 5 - Remove gas supply line connected to gas valve. Disconnect gas valve sensing hose from valve. Remove burner box cover (4 to 6 screws). Remove gas valve/manifold assembly.
- 6 - Loosen hose clamp holding the air intake pipe to the no-hub connector on the top of the burner box. Remove pipe from no-hub connector and set aside.
- 7 - Mark and disconnect spark or SureLight ignitor and sensor electrical wires from the ignitor and flame sensor.
- 8 - Detach burner box from vestibule panel by removing four securing screws. Take care to avoid damaging the glass fiber gasket.
- 9 - On GHR26-50 and -75 units, remove air intake fitting from burner box top.
- 10 - Remove burner box top from burner box assembly.
- 11 - Using 1/4" nut driver, remove two screws holding burners in place. Slide burner assembly out of burner box.
- 12 - Clean burner by running a vacuum with a soft brush attachment over face of burners. Visually inspect inside of burners and crossovers for any blockage caused by foreign matter. Remove any blockage.
- 13 - Re-install burner assembly so that protruding side (not cavity side) of metal buttons are toward the burner box top (intake side).
- 14 - Replace top and air intake piece to burner box.
- 15 - Reconnect sensor and spark electrode or SureLight ignitor wires.
- 16 - Align burner box gasket to securing holes closest to the end of the unit. Use a small piece of tape to secure gasket to vest panel. Make sure glass fiber gasket has not been damaged so it will provide a continuous seal between the burner box and the vestibule panel.
- 17 - Replace four screws to secure reassembled burner box assembly to vestibule panel. **Make sure burners line up in center of burner ports.**
- 18 - Re-install gas valve/manifold assembly. Re-install burner box cover. Reconnect gas valve sensing hose to side of burner box. Re-install gas supply line to gas valve.

- 19- Reconnect gas valve wires to gas valve.
- 20- Replace both upper and lower access panels.
- 21- Refer to instruction on verifying gas and electrical connections when re-establishing supply.
- 22- Following lighting instructions, light and run unit for 5 minutes to ensure heat exchanger is clean, dry and operating safely.

C-Supply Air Blower

- 1 - Check and clean blower wheel.
- 2 - Motors are prelubricated for extended life; no further lubrication is required.

D-Flue and Chimney

Flue must conform to all AGA/GAMA venting requirements. Flue pipe deteriorates from the inside out and must be disconnected in order to check thoroughly. Check flue pipe, chimney and all connections for tightness and to make sure there is no blockage or leaks.

E-Electrical

- 1 - Check all wiring for loose connections.
- 2 - Check circuit breaker located in unit control box.
- 3 - Check for correct voltage at unit (unit operating).
- 4 - Check amp-draw on blower motor.
Motor Nameplate _____ Actual _____
- 5 - Check to see that heat (if applicable) is operating.

F-Intake and Exhaust Lines

Check intake and exhaust lines and all connections for tightness and make sure there is no blockage. Also check condensate line for free flow during operation.

G-Insulation

Outdoor piping insulation should be inspected yearly for deterioration. If necessary, replace with same materials.

H-Winterizing and Condensate Trap Care

If the unit is to be shut down for an extended period of time and will be exposed to sub-freezing temperatures, the unit should be winterized by draining water from the condensate trap.

To drain condensate trap remove the 3/8" cap located on the bottom corner of the condensate trap (see figure 33). Periodically drain condensate trap to insure proper drainage and check for blockage.

VII-WIRING DIAGRAM AND SEQUENCE OF OPERATION

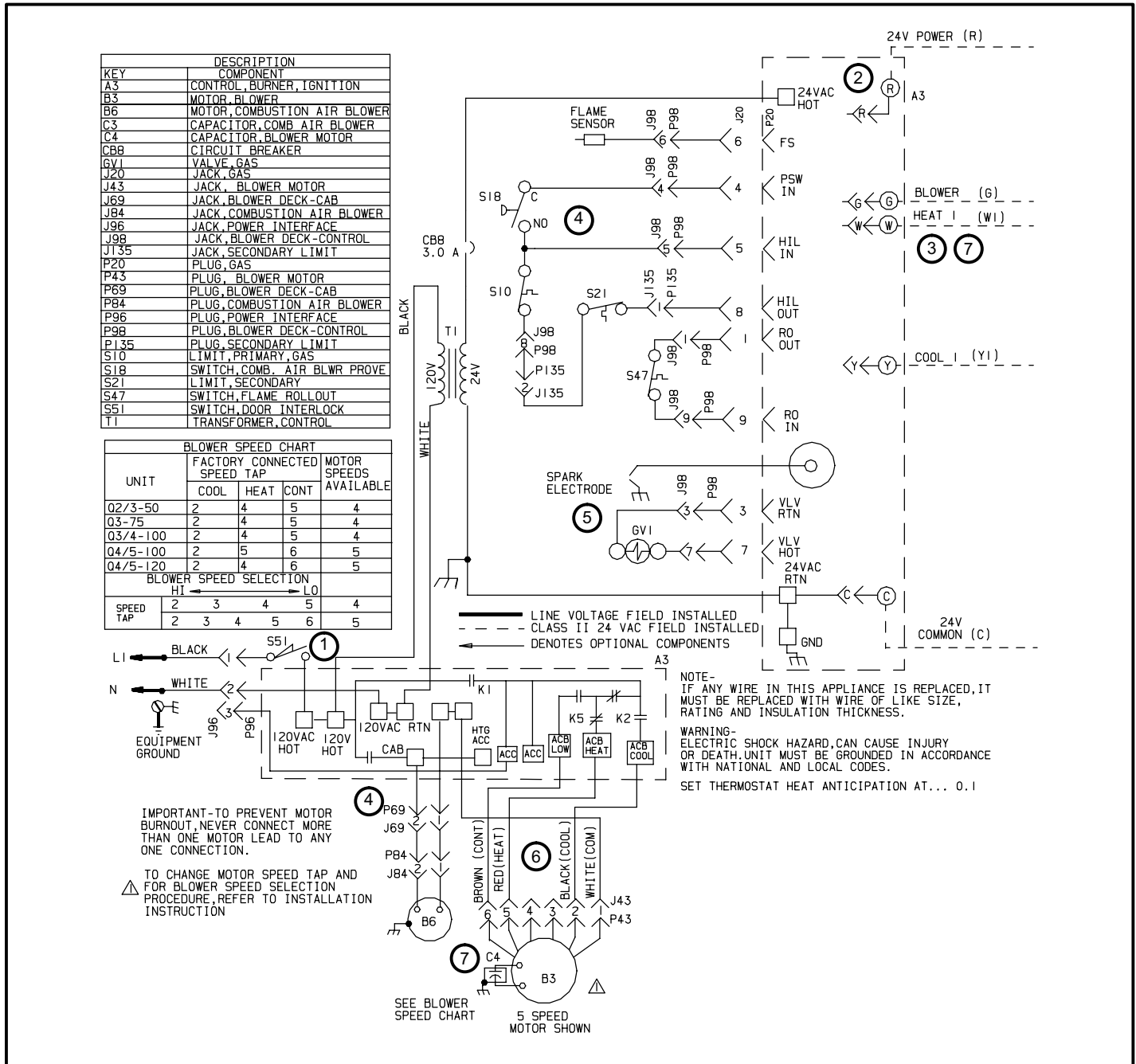

GHR26-1 MODELS DIRECT SPARK OPERATION SEQUENCE

(FOR A MORE DETAILED DESCRIPTION SEE THE FLOW CHARTS ON THE FOLLOWING TWO PAGES):

- 1 - When disconnect is closed, 120V is routed through door interlock switch (S51) to feed the line voltage side of the ignition control (A3) and transformer T1 primary. Door interlock switch must be closed for A3 and T1 to receive voltage.
- 2 - T1 supplies 24VAC to terminal "24VAC" on A3. In turn, terminal "R" of A3 supplies 24VAC to terminal "RC" of the indoor thermostat (not shown).
- 3 - When there is a call for heat, W1 of the thermostat energizes W of the ignition control with 24VAC.
- 4 - CAB of the ignition control energizes the combustion air blower (B6). When the combustion air blower nears full speed, combustion air prove switch (S18) closes.
- 5 - When S18 closes, assuming primary limit (S10) and secondary limit (S21) are closed, the ignition control starts ignition spark and opens main gas valve.
- 6 - After 45 seconds, ignition control (A3) energizes the indoor blower (B3).
- 7 - When heat demand is satisfied, W1 of the thermostat de-energizes W of the ignition control and the gas valve is immediately de-energized. The combustion air blower immediately stops. The indoor blower runs for a designated fan "off" period (60-240 seconds) as set by jumper on ignition control.

COOLING SEQUENCE OF OPERATION

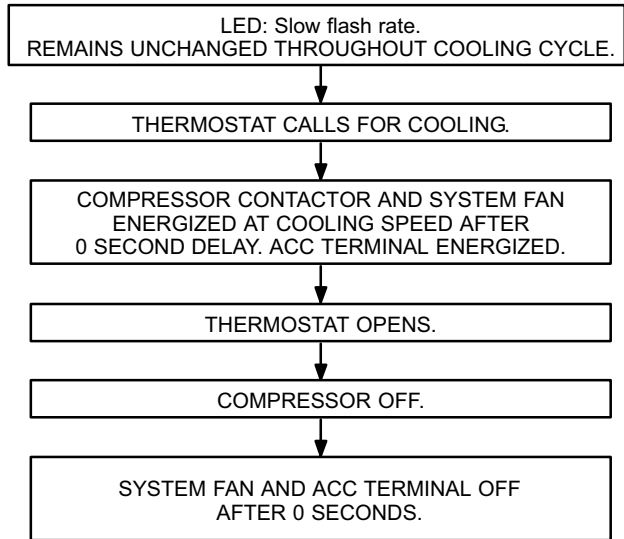

MANUAL FAN SEQUENCE OF OPERATION

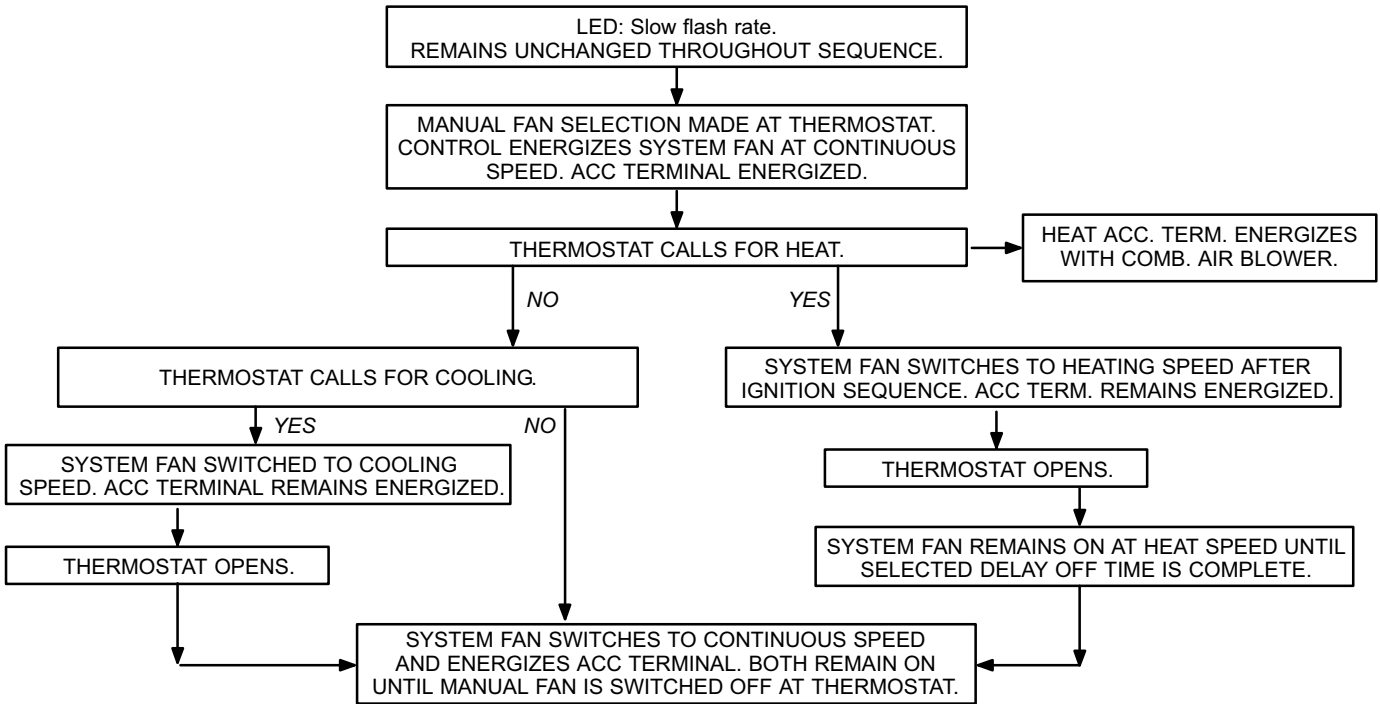

HEATING SEQUENCE OF OPERATION

NORMAL HEATING MODE

ABNORMAL HEATING MODE

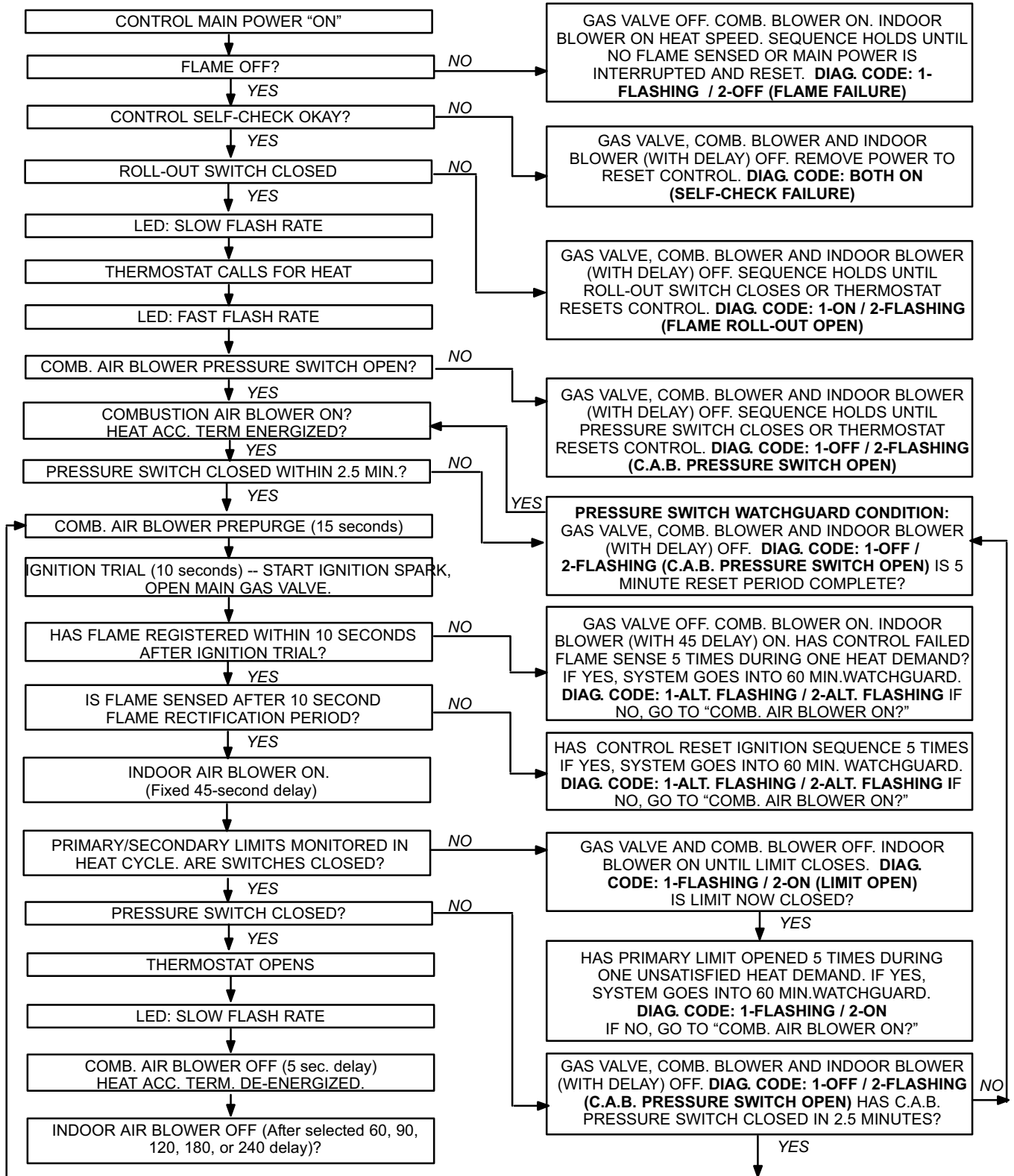

TYPICAL GHR26 DIAGRAM (-6, -7 & -8 SHOWN)

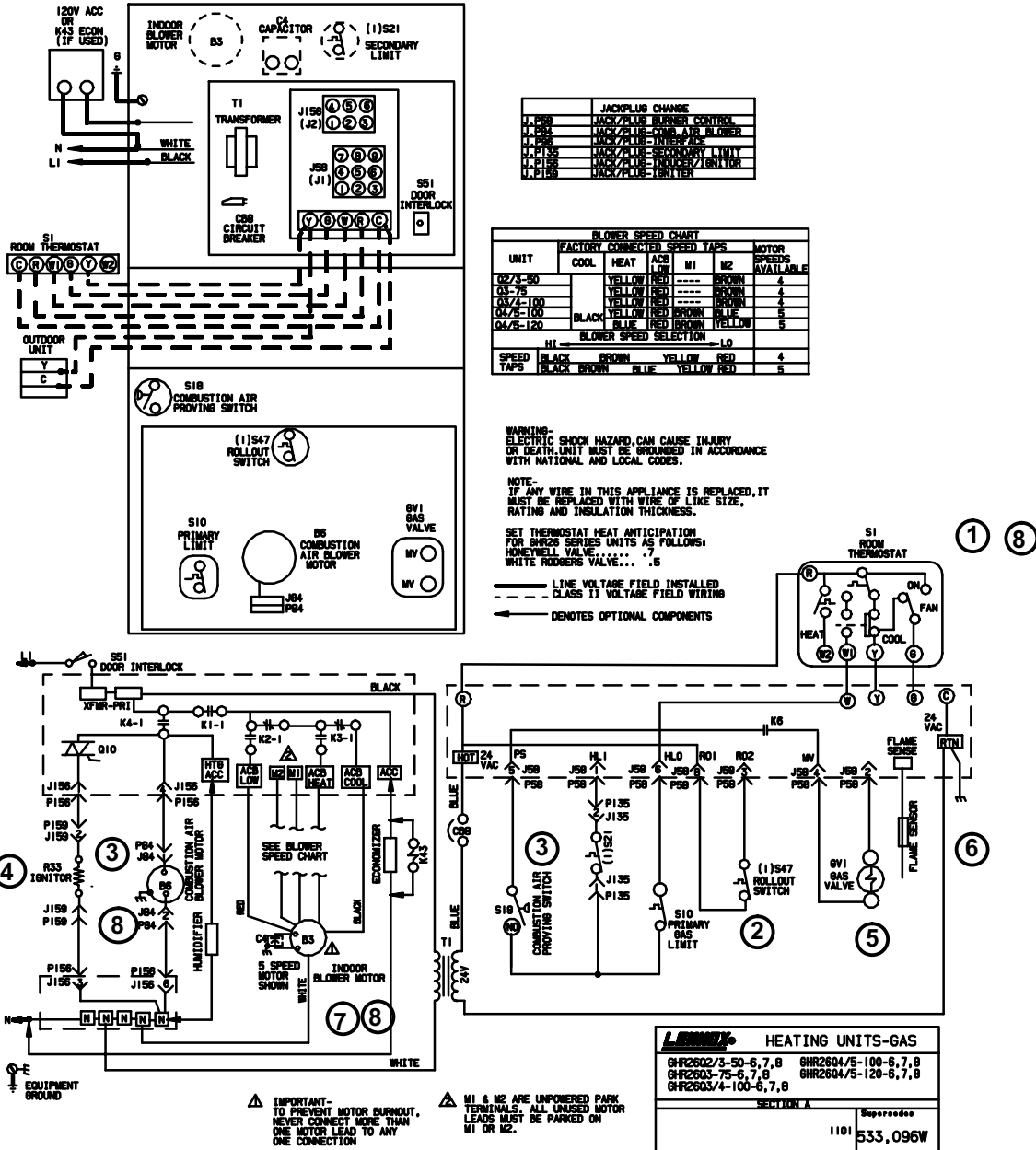

GHR26-2 THROUGH -8 MODELS WITH SURELIGHT CONTROL OPERATION SEQUENCE

- 1 - When there is a call for heat, W1 of the thermostat energizes W of the furnace control with 24VAC.
- 2 - S10 primary limit switch and S47 rollout switch are closed. Call for heat can continue.
- 3 - Surelight control energizes combustion air blower B6. Combustion air blower runs until S18 combustion air prove switch closes (switch must close within 2-1/2 minutes or control goes into 5 minute Watchguard Pressure Switch delay). Once S18 closes, a 15-second pre-purge follows.
- 4 - Surelight control energizes ignitor. A 20-second warm-up period begins.
- 5 - Gas valve opens for a 4-second trial for ignition.
- 6 - Flame is sensed, gas valve remains open for the heat call.
- 7 - After 45-second delay, Surelight control energizes indoor blower B3.
- 8 - When heat demand is satisfied, W1 of the indoor thermostat de-energizes W of the Surelight control which de-energizes the gas valve. Combustion air blower B6 continues a 5-second post-purge period, and indoor blower B3 completes a selected OFF time delay.

HEATING SEQUENCE OF OPERATION SURELIGHT CONTROL

NORMAL HEATING MODE

ABNORMAL HEATING MODE

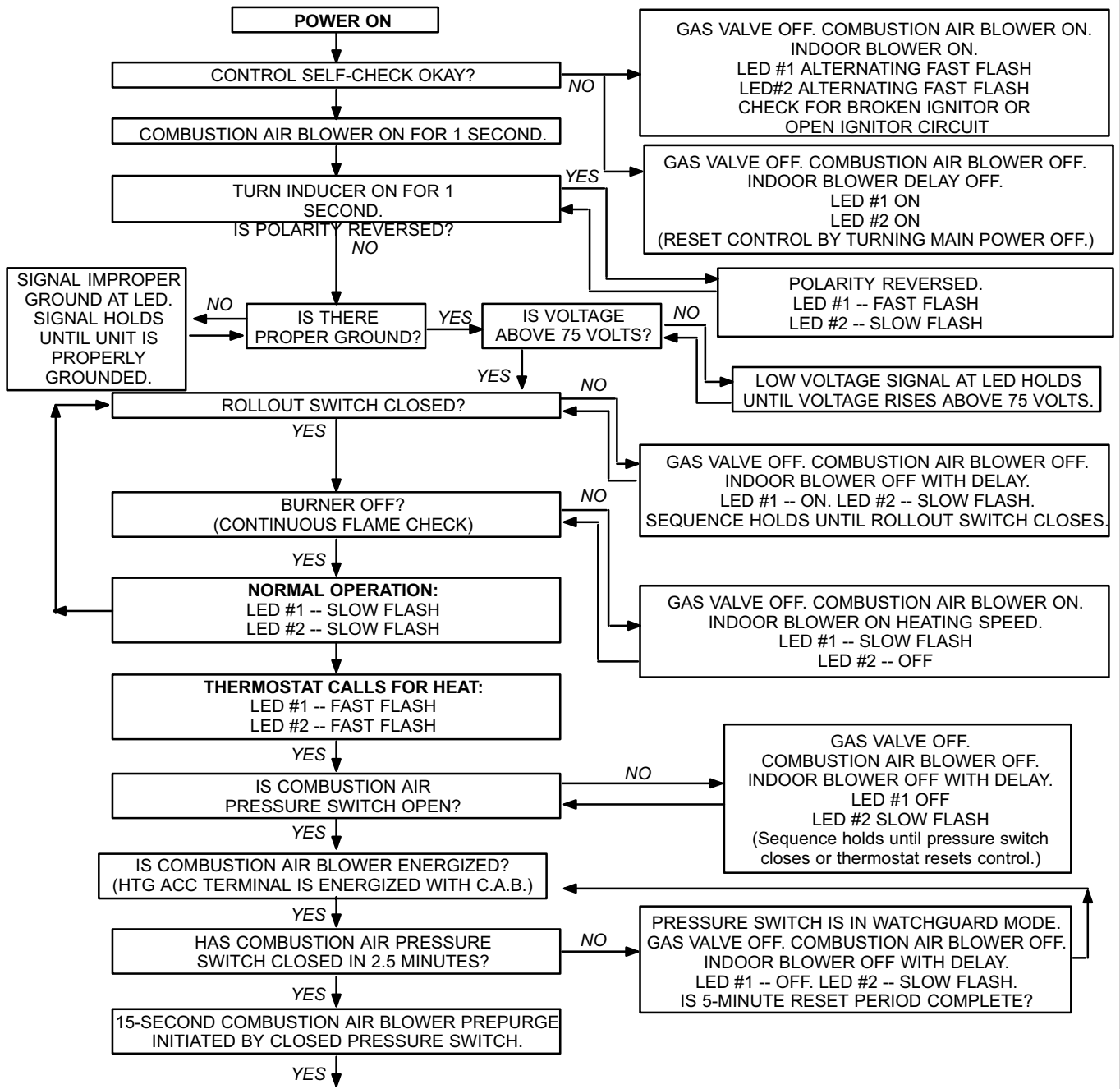

CONTINUED NEXT PAGE

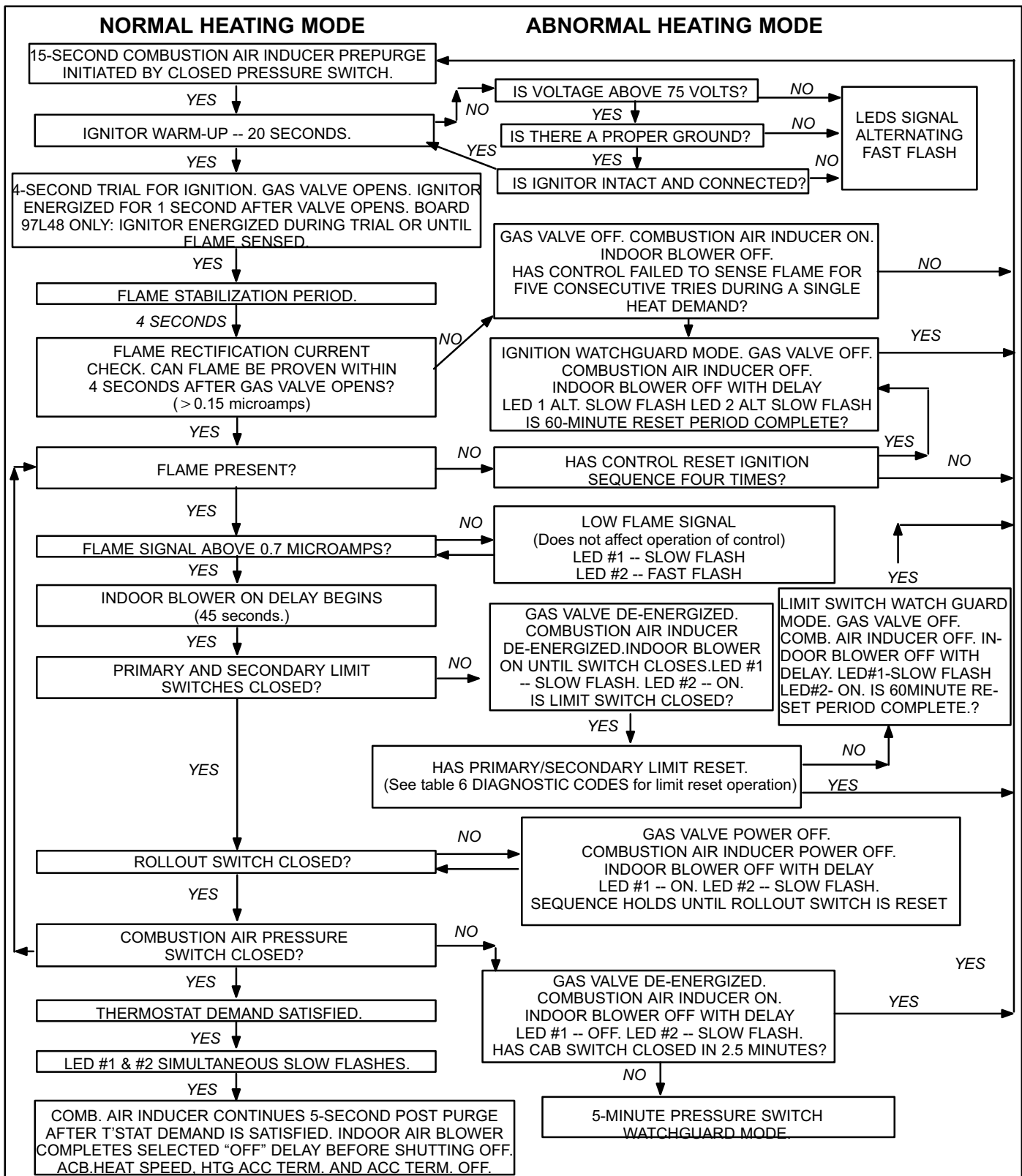

COOLING SEQUENCE OF OPERATION SURELIGHT CONTROL

NORMAL COOLING MODE

ABNORMAL COOLING MODE

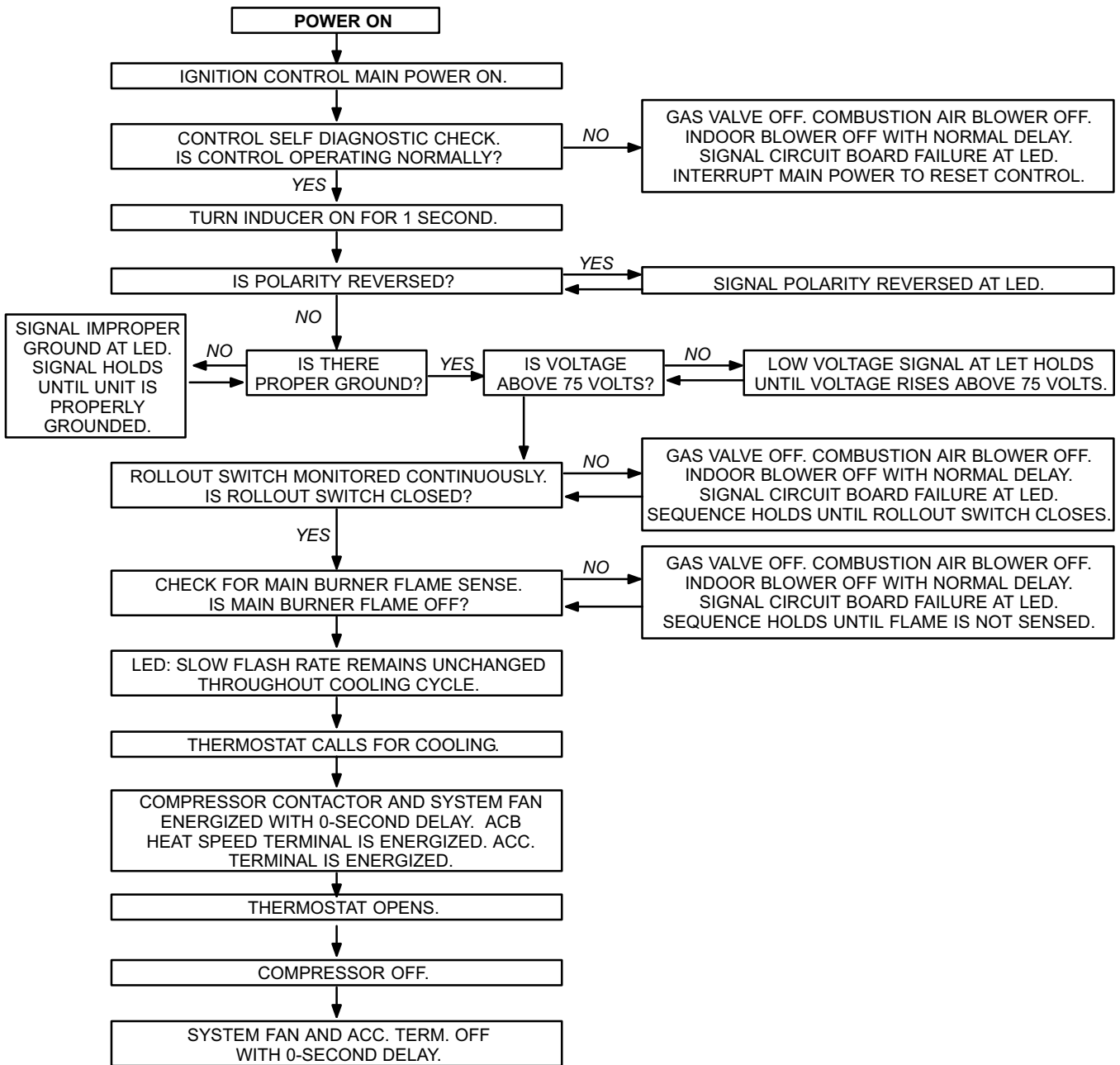

CONTINUOUS LOW SPEED FAN SEQUENCE OF OPERATION SURELIGHT CONTROL

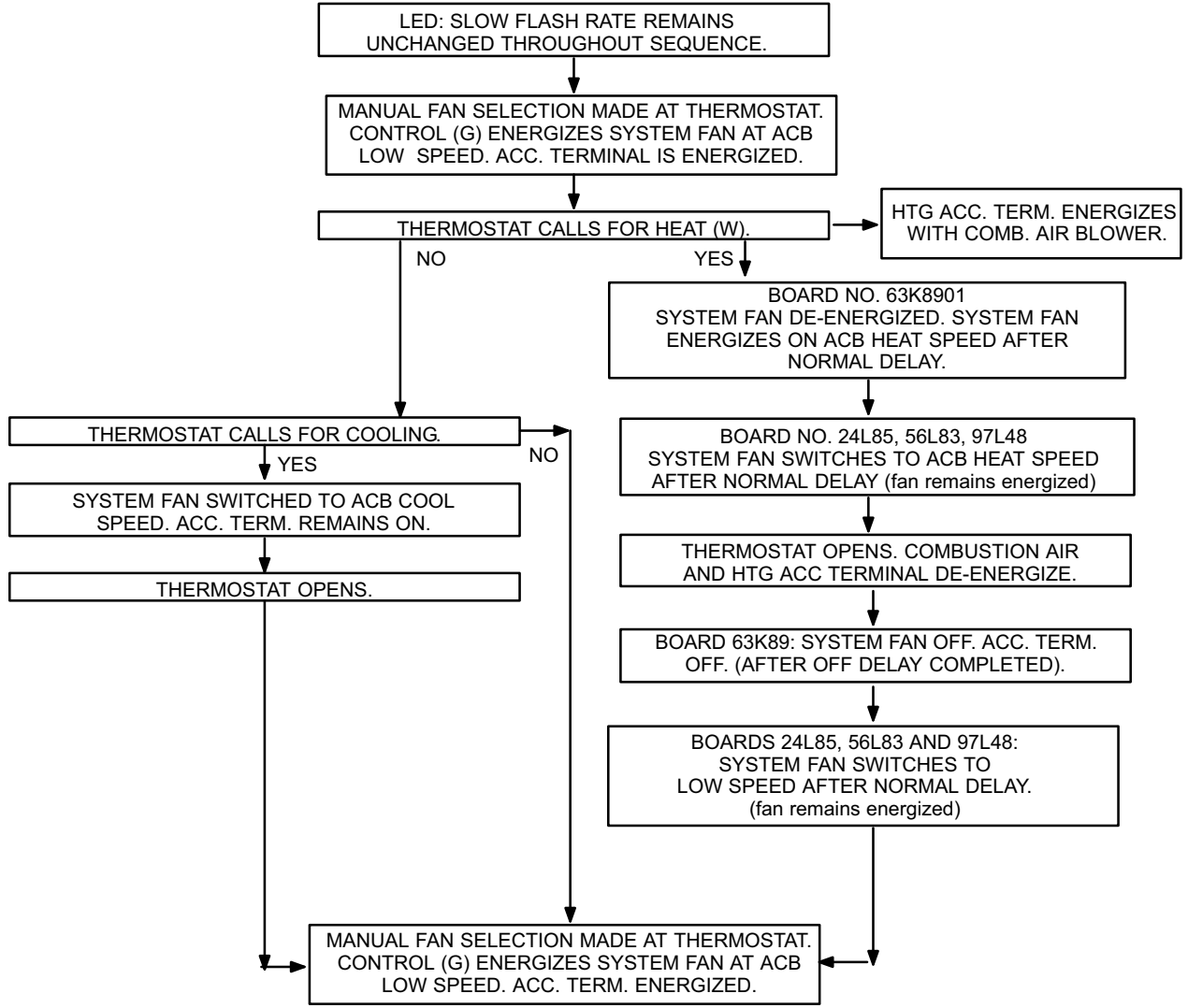

VIII- Trouble Shooting Guide

SureLight Control

UPON INITIAL POWER UP, REMOVE ALL THERMOSTAT DEMANDS TO THE UNIT

PROBLEM: 1 UNIT FAILS TO OPERATE IN THE COOLING, HEATING, OR CONTINUOUS FAN MODE		
Condition	Possible Cause	Corrective Action / Comments
<p>1.1</p> <p>- Both diagnostic lights fail to light up.</p> <p>LED#1-Off LED#2-Off</p>	<p>1.1.1</p> <p>Main voltage 120V not supplied to unit.</p>	<p>ACTION 1 - Check 120V main voltage. Determine cause of main power failure.</p>
	<p>1.1.2</p> <p>Miswiring of furnace or improper connections.</p>	<p>ACTION 1 - Check for correct wiring of 120V to power make up box and transformer. ACTION 2 - Check 24V wiring to control board.</p>
	<p>1.1.3</p> <p>Circuit breaker tripped or fails to close.</p>	<p>ACTION 1 - Replace circuit breaker if it is reset but does not have continuity. ACTION 2 - If circuit breaker still trips, check for short.</p>
	<p>1.1.4</p> <p>Door interlock switch failure.</p>	<p>ACTION 1 - Check that door switch is activated when door is closed. ACTION 2 - Check wire connections to switch, replace loose connectors. ACTION 3 - Check continuity of switch in closed position. Replace if malfunctioning</p>
	<p>1.1.5</p> <p>Transformer Failure.</p>	<p>ACTION 1 - Check that transformer output is 24V. Replace if malfunctioning</p>
	<p>1.1.6</p> <p>Failed control board.</p>	<p>ACTION 1 - If all the above items have been checked, replace board.</p>
<p>1.2</p> <p>- Diagnostic lights flash the roll-out code.</p> <p>LED#1-On, LED#2-Slow Flash</p>	<p>1.2.1</p> <p>Roll-out switch open.</p>	<p>ACTION 1 - Manually reset the roll-out switch by pushing the top button. ACTION 2 - Determine the cause of the roll-out switch activation before leaving furnace.</p>
	<p>1.2.2</p> <p>Roll-out switch failure.</p>	<p>ACTION 1 - Check continuity across roll-out switch. Replace roll-out switch if switch is reset but does not have continuity.</p>
	<p>1.2.3</p> <p>Miswiring or improper connections at roll-out switch.</p>	<p>ACTION 1 - Check wiring connections to switch.</p>
	<p>1.2.4</p> <p>Nine pin connector failure</p>	<p>ACTION 1 - Check 9-pin connector for proper connection to control board. ACTION 2 - Check continuity of the multi plug pin.</p>
<p>1.3</p> <p>- On initial power-up the comb. air blower does not energize. - Diagnostic lights flash the reverse polarity code.</p> <p>LED#1-Fast Flash, LED#2-Slow Flash.</p>	<p>1.3.1</p> <p>120V main power polarity reversed.</p>	<p>ACTION 1 - Check the 120V has line and neutral correctly input into control. ACTION 2 - Reverse the line and neutral at the 120V field connection.</p>
<p>1.4</p> <p>- On initial power up the combustion air blower does not energize. - Diagnostic lights flash normal power on operation.</p> <p>LED#1-Slow Flash LED#2-Slow Flash</p>	<p>1.4.1</p> <p>Open combustion air blower motor circuit.</p>	<p>ACTION 1 - Check for 120V to combustion air blower. If no power, check wire and connections.</p>
	<p>1.4.2</p> <p>Failed combustion air blower motor.</p>	<p>ACTION 1 - If power is present at blower, replace blower.</p>

PROBLEM 1: UNIT FAILS TO OPERATE IN THE COOLING, HEATING, OR CONTINUOUS FAN MODE

Condition	Possible Cause	Corrective Action / Comments
<p>1.5</p> <ul style="list-style-type: none"> - On initial power-up the combustion air blower remains energized. - Diagnostic lights flash the improper main ground. <p>LED#1-Alternating Fast Flash LED#2-Alternating Fast Flash</p>	<p>1.5.1</p> <p>Improper ground to the unit.</p>	<p>ACTION 1 - Check that the unit is properly ground. ACTION 2 - Install a proper main ground to the unit</p>
	<p>1.5.2</p> <p>6-Pin connector is improperly attached to the circuit board.</p>	<p>ACTION 1 - Check 6-pin connector for proper installation. Correctly insert connector into control.</p>
	<p>1.5.3</p> <p>Line voltage is below 75V.</p>	<p>ACTION 1 - Check that the line voltage is above 75V. Determine cause of voltage drop and supply correct voltage to the control.</p>

PROBLEM 2: UNIT FAILS TO OPERATE IN THE COOLING OR HEATING MODE, BUT COMBUSTION AIR BLOWER OPERATES CONTINUOUS. UNITS WITH CONTROL BOARDS DATE CODED AFTER NOV. 1 1997, WILL OPERATE IN COOLING BUT NOT IN THE HEATING MODE, WITH COMBUSTION AIR BLOWER CYCLING 5 SECONDS ON 55 SECONDS OFF.

Condition	Possible Cause	Corrective Action / Comments
<p>2.1</p> <ul style="list-style-type: none"> - On initial power-up the combustion air blower remains energized. - Diagnostic lights flash the improper main ground. - Units with control boards date coded after Nov.1 1997, will cycle 5 seconds on 55 seconds off. <p>LED#1-Alternating Fast Flash LED#2-Alternating Fast Flash</p>	<p>2.1.1</p> <p>Open ignitor circuit.</p>	<p>ACTION 1 - Check for correct wiring and loose connections in the ignitor circuit. Check multi-plug connections for correct installation.</p>
	<p>2.1.2</p> <p>Broken or failed ignitor.</p>	<p>ACTION 1 - Unplug ignitor and read resistance across ignitor. If resistance does not read between 10.9 and 19.7 ohms, replace the ignitor.</p>

PROBLEM 3: UNIT FAILS TO FIRE IN THE HEATING MODE, COMBUSTION AIR BLOWER DOES NOT ENERGIZE

Condition	Possible Cause	Corrective Action / Comments
<p>3.1</p> <ul style="list-style-type: none"> - Unit operates with a cooling or continuous fan demand. - Combustion air blower will not start with a Heating demand. - Diagnostic lights flash the limit failure mode. <p>LED#1-Slow Flash, LED#2-On</p>	<p>3.1.1</p> <p>Primary or secondary (if equipped) limit open.</p>	<p>ACTION 1 - Check continuity across switch(es). Switches reset automatically upon cool down. ACTION 2 - Check for restrictions on blower inlet air (including filter) and outlet air. Determine cause for limit activation before placing unit back in operation.</p>
	<p>3.1.2</p> <p>Miswiring of furnace or improper connections at limit switch(es).</p>	<p>ACTION 1 - Check for correct wiring and loose connections. Correct wiring and/or replace any loose connections.</p>
<p>3.2</p> <ul style="list-style-type: none"> - Unit operates with a cooling and continuous fan demand. - Combustion air blower will not start with a Heating demand. - Diagnostic lights flash the pressure switch failure code. <p>LED#1-Off, LED#2-Slow Flash</p>	<p>3.2.1</p> <p>Miswiring of furnace or improper connections to combustion air blower.</p>	<p>ACTION 1 - Check for correct wiring and loose connections. Correct wiring and/or replace any loose connections.</p>
	<p>3.2.2</p> <p>Pressure switch stuck closed.</p>	<p>ACTION 1 - Check that the pressure switch is open without the combustion air blower operating. Replace if malfunctioning</p>

PROBLEM 3: UNIT FAILS TO FIRE IN THE HEATING MODE, COMBUSTION AIR BLOWER DOES NOT ENERGIZE (CONT.).

Condition	Possible Cause	Corrective Action/Comments
<p>3.3</p> <ul style="list-style-type: none"> - Unit operates with a cooling and continuous fan demand. - Combustion air blower will not start with a Heating demand. - Diagnostic lights flash the pressure switch failure code 2.5 minutes after heating demand. <p>LED#1-Off, LED#2-Slow Flash</p>	<p>3.3.1</p> <p>Miswiring of furnace or improper connections to combustion air blower.</p>	<p>ACTION 1 - Check for correct wiring and loose connections. Correct wiring and/or replace any loose connections.</p>
	<p>3.3.2</p> <p>Combustion air blower failure.</p>	<p>ACTION 1 - If there is 120V to combustion air blower and it does not operate, replace combustion air blower.</p>

PROBLEM 4: UNIT FAILS TO FIRE IN THE HEATING MODE, COMBUSTION AIR BLOWER ENERGIZES, IGNITOR IS NOT ENERGIZED.

Condition	Possible Cause	Corrective Action/Comments
<p>4.1</p> <ul style="list-style-type: none"> - Unit operates with a cooling and continuous fan demand. - Combustion air blower energizes with a heating demand. - Diagnostic lights flash the pressure switch failure code 2.5 minutes after heating demand. <p>LED#1-Off LED#2-Slow Flash</p>	<p>4.1.1</p> <p>Pressure switch does not close due to incorrect routing of the pressure switch lines.</p>	<p>ACTION 1 - Check that the pressure switch lines are correctly routed. Correctly route pressure switch lines.</p>
	<p>4.1.2</p> <p>Pressure switch does not close due to obstructions in the pressure lines.</p>	<p>ACTION 1 - Remove any obstructions from the the pressure lines and/or taps.</p>
	<p>4.1.3</p> <p>Pressure switch lines damaged</p>	<p>ACTION 1 - Check pressure switch lines for leaks. Replace any broken lines.</p>
	<p>4.1.4</p> <p>Condensate in pressure switch line.</p>	<p>ACTION 1 - Check pressure switch lines for condensate. Remove condensate from lines. Check that the condensate lines are located correctly.</p>
	<p>4.1.5</p> <p>Pressure switch does not close due to a low differential pressure across the pressure switch.</p>	<p>ACTION 1 - Check the differential pressure across the pressure switch. This pressure should exceed the set point listed on the switch. ACTION 2 - Check for restricted inlet and exhaust vent. Remove all blockage. ACTION 3 - Check for proper vent sizing and run length. See installation instructions.</p>
	<p>4.1.6</p> <p>Wrong pressure switch installed in the unit, or pressure switch is out of calibration.</p>	<p>ACTION 1 - Check that the proper pressure switch is installed in the unit. Replace pressure switch if necessary.</p>
	<p>4.1.7</p> <p>Miswiring of furnace or improper connections at pressure switch.</p>	<p>ACTION 1 - Check for correct wiring and loose connections. Correct wiring and/or replace any loose connections.</p>
	<p>4.1.8</p> <p>Pressure switch failure.</p>	<p>ACTION 1 - If all the above modes of failure have been checked, the pressure switch may have failed. Replace pressure switch and determine if unit will operate.</p>
	<p>4.1.9</p> <p>Condensate line from header box to trap is bowed up or down causing a vapor lock and blocked condensate condition.</p>	<p>ACTION 1 - Reduce length of condensate line tube and straighten condensate line between header box and trap. Units built between 8/95 and 10/95 have slightly longer condensate lines and may exhibit this problem more frequently.</p>

PROBLEM 5: UNIT FAILS TO FIRE IN THE HEATING MODE, COMBUSTION AIR BLOWER ENERGIZES, IGNITOR IS ENERGIZED. (CONT.)

Condition	Possible Cause	Corrective Action/Comments
<p align="center">5.1</p> <ul style="list-style-type: none"> - Unit operates with a cooling and continuous fan demand. - Combustion air blower energizes with Heating demand. - Ignitor is energized but unit fails to light. <p>LED#1-Alternating Slow Flash LED#2-Alternating Slow Flash</p>	5.1.1 Check that gas is being supplied to the unit.	ACTION 1 - Check line pressure at the gas valve. Pressure should not exceed 13" WC for both natural and propane. Line pressure should read a minimum 4.5" WC for natural and 8.0"WC for propane.
	5.1.2 Miswiring of gas valve or loose connections at multi-pin control amp plugs or valve.	ACTION 1 - Check for correct wiring and loose connections. Correct wiring and/or replace any loose connections.
	5.1.3 Malfunctioning gas valve or ignition control.	ACTION 1 - Check that 24V is supplied to the gas valve approximately 35 seconds after heat demand is initiated. ACTION 2 - Replace the valve if 24V is supplied but valve does not open (check for excessive gas line pressure before replacing gas valve). ACTION 3 - Replace the control board if 24V is not supplied to valve.

PROBLEM 6: BURNERS LIGHT WITH A HEATING DEMAND BUT UNIT SHUTS DOWN PREMATURELY

Condition	Possible Cause	Corrective Action/Comments
<p align="center">6.1</p> <ul style="list-style-type: none"> - Burners fire with a heating demand. - Burners light but unit shuts off prior to satisfying T-stat demand. - Diagnostic lights flash the pressure switch code. <p>LED#1-Off LED#2-Slow Flash</p>	6.1.1 Wrong concentric vent kit used for terminating the unit.	ACTION 1 - Check vent termination kit installed. 1-1/2" dia. concentric vent (kit60G77) for 50 and 75 inputs and 2" dia. concentric vent (kit 33K97) for 100 &125 inputs.
	6.1.2 Condensate drain line is not draining properly.	ACTION 1 - Check condensate line for proper vent slope, and any blockage. Condensate should flow freely during operation of furnace. Repair or replace any improperly installed condensate lines.
	6.1.3 Low pressure differential at the pressure switch.	ACTION 1 - Check for restricted vent inlet or exhaust. Remove all blockage. ACTION 2: Check for proper vent sizing. See installation instructions.
<p align="center">6.2</p> <ul style="list-style-type: none"> - Combustion air blower energizes with a heating demand. - Burners light but fail to stay lit. - After 5 tries the control diagnostics flash the watchdog burners failed to ignite code. <p>LED#1-Alternating Slow Flash LED#2-Alternating Slow Flash</p>	6.2.1 Sensor or sense wire is improperly installed.	ACTION 1 - Check that sensor is properly located (page 10) and that the sense wire is properly attached to both the sensor and the control.
	6.2.2 Sensor or sense wire is broken.	ACTION 1 - Check for a broken sensor. ACTION 2 - Test continuity across the sense wire. If wire or sensor are damaged replace the component.
	6.2.3 Sensor or sensor wire is grounded to the unit.	ACTION 1 - Check for resistance between the sensor rod and the unit ground. ACTION 2 - Check for resistance between the sensor wire and the unit ground. ACTION 3 - Correct any shorts found in circuit.
	6.2.4 Control does not sense flame.	ACTION 1 - Check the microamp signal from the burner flame. If the microamp signal is below 0.70 microamps, check the sense rod for proper location or contamination. ACTION 2 - Replace, clean, or relocate flame sense rod. If rod is to be cleaned, use steel wool or replace sensor. DO NOT CLEAN ROD WITH SAND PAPER. SAND PAPER WILL CONTRIBUTE TO THE CONTAMINATION PROBLEM. NOTE: Do not attempt to bend sense rod.

**PROBLEM 6: BURNERS LIGHT WITH HEATING DEMAND BUT UNIT SHUTS DOWN
PREMATURELY (CONT.)**

Condition	Possible Cause	Corrective Action/Comments
<p align="center">6.3</p> <ul style="list-style-type: none"> - Combustion air blower energizes with a heating demand. - Burners light. - Roll-out switch trips during the heating demand. - Diagnostic lights flash roll-out failure. <p>LED#1-On LED#2-Slow Flash</p>	<p align="center">6.3.1</p> <p align="center">Unit is firing above 100% of the nameplate input.</p>	<p>ACTION 1 - Check that the manifold pressure matches value listed on nameplate. See installation instructions for proper procedure.</p> <p>ACTION 2 - Verify that the installed orifice size match the size listed on the nameplate or installation instructions.</p> <p>ACTION 3 - Check gas valve sensing hose to insure no leaks are present.</p> <p>ACTION 4 - Check the input rate to verify rate matches value listed on nameplate.</p>
	<p align="center">6.3.2</p> <p align="center">Gas orifices leak at the manifold connection.</p>	<p>ACTION 1 - Tighten orifice until leak is sealed.</p> <p>NOTE: Be careful not to strip orifice threads. ACTION 2 - Check for gas leakage at the threaded orifice connection. Use approved method for leak detection (see unit instructions).</p>
	<p align="center">6.3.3</p> <p align="center">Air leakage at the connections between the primary heat exchanger, secondary heat exchanger, and combustion air blower.</p>	<p>ACTION 1 - Check for air leakage at all joints in the heat exchanger assembly. Condition will cause high CO₂ with high CO.</p> <p>ACTION 2 - Seal leakage if possible (high temperature silicon is recommended), replace heat exchanger if necessary, tag and return heat exchanger to proper Lennox personnel.</p>
	<p align="center">6.3.4</p> <p align="center">Insufficient flow through the heat exchanger caused by a sooted or restricted heat exchanger.</p>	<p>ACTION 1 - Check for sooting deposits or other restrictions in the heat exchanger assembly. Clean assembly as outlined in instruction manual.</p> <p>ACTION 2 - For GHR26 gas furnaces, check for proper combustion and flow. CO₂ should measure between 6.0% and 8.0% for NG and between 7.0% and 9.0% for LP. CO should measure below .04% (400PPM) in an air-free sample of flue gases for either NG or LP.</p>
	<p align="center">6.3.5</p> <p align="center">Burners are not properly located in the burner box.</p>	<p>ACTION 1 - Check that the burners are firing into the center of the heat exchanger openings. Correct the location of the burners if necessary.</p>
<p align="center">6.4</p> <ul style="list-style-type: none"> - Combustion air blower energizes with a heating demand. - Burners light roughly and the unit fails to stay lit. - Diagnostic lights flash watchguard flame failure. <p>LED#1-Alternating Slow Flash LED#2-Alternating Slow Flash</p>	<p align="center">6.4.1</p> <p align="center">Recirculation of flue gases. This condition causes rough ignitions and operation. Problem is characterized by nuisance flame failures.</p>	<p>ACTION 1 - Check for proper flow of exhaust gases away from intake vent. Remove any obstacles in front of the intake and exhaust vent which would cause recirculation.</p> <p>ACTION 2 - Check for correct intake and exhaust vent installation. See instructions</p>
	<p align="center">6.4.2</p> <p align="center">Improper burner cross-overs</p>	<p>ACTION 1 - Remove burner and inspect the cross-overs for burrs, or any restriction or if cross-over is warped. Remove restriction or replace burners.</p>

PROBLEM 6: BURNERS LIGHT WITH HEATING DEMAND BUT UNIT SHUTS DOWN PREMATURELY (CONT.)

<p align="center">6.5</p> <ul style="list-style-type: none"> - Combustion air blower energizes with a heating demand. - Burners light. - Diagnostic lights flash watch guard flame failure. - NOTE” Unit might go into 60 minute Watchguard mode depending on intermittent nature of sensor signal. <p>LED#1-Alternating Slow Flash LED#2-Alternating Slow Flash</p>	<p align="center">6.5.1</p> <p>Loose sensor wire connection causes intermittent loss of flame signal.</p>	<p>ACTION 1 - Check that the sensor is properly located.</p> <p>ACTION 2 - Check that the sense wire is properly attached to both the sensor and the control. Pay extra attention to the pin connectors.</p>
---	--	--

PROBLEM 7: CONTROL SIGNALS LOW FLAME SENSE DURING HEATING MODE

Condition	Possible Cause	Corrective Action/Comments
<p align="center">7.0</p> <ul style="list-style-type: none"> - Unit operates correctly but the diagnostic lights flash low flame sense code. <p>LED#1-Slow Flash LED#2-Fast Flash</p>	<p align="center">7.1.1</p> <p>Sense rod is improperly located on the burner.</p>	<p>ACTION 1 - Check the sense rod for proper location on the burner. Properly locate the sense rod or replace if rod cannot be located correctly.</p>
	<p align="center">7.1.2</p> <p>Sense rod is contaminated.</p>	<p>ACTION 1 - Check sense rod for contamination or coated surface. Clean the sense rod with steel wool or replace sensor. DO NOT USE SAND PAPER TO CLEAN ROD. SAND PAPER WILL CONTRIBUTE TO THE CONTAMINATION PROBLEM.</p>

PROBLEM 8: INDOOR BLOWER FAILS TO OPERATE IN COOLING, HEATING, OR CONTINUOUS FAN MODE

Condition	Possible Cause	Corrective Action/Comments
<p align="center">8.0</p> <ul style="list-style-type: none"> - Indoor blower fails to operate in continuous fan, cooling, or heating mode. 	<p align="center">8.1.1</p> <p>Miswiring of furnace or improper connections at control or indoor blower motor.</p>	<p>ACTION 1 - Correct wiring and/or replace any loose connections. Check for correct wiring and loose connections.</p>
	<p align="center">8.1.2</p> <p>120V is not being supplied to the indoor air blower or blower motor failure.</p>	<p>ACTION 1 - Check for 120V at the various calls for indoor blower by energizing "Y", "G", and "W" individually on the low voltage terminal strip. Note that when "W" is energized, the blower is delayed 45 seconds. If there is 120V to each motor tap but the blower does not operate, replace the motor.</p>
	<p align="center">8.1.3</p> <p>Defective control board</p>	<p>ACTION 1 - If there is not 120V when "Y", "G", or "W" is energized, replace the control.</p>

PROBLEM 9: RF STATIC DURING TIME FOR IGNITION

Condition	Possible Cause	Corrective Action/Comments
<p align="center">9.0</p> <p>-AM radio interference</p>	<p align="center">9.1.2</p> <p>Ignitor operation</p>	<p>ACTION 1 - Call Technical Support, Dallas</p>

NOTES