

SERVICE UNIT INFORMATION GS11/GS11E

Litho U.S.A.

GS11 AND GS11E SERIES UNITS

I - INTRODUCTION

The GS11 and GS11E are horizontal furnaces. The GS11 uses a standing pilot with a thermocouple to verify flame. In the event of pilot outage, the gas valve locks itself out in response to the thermocouple.

GS11E uses electronic ignition systems to light pilot on each operating cycle (intermittent pilot). A protection circuit verifies pilot flame to allow main burner ignition. Main burner and pilot are extinguished during the off cycle. If the pilot does not light, the main gas valve will not open.

The units are manufactured for natural gas applications, but an L.P. gas field changeover kit is available. Figure 1 shows a cased view of a GS11E.

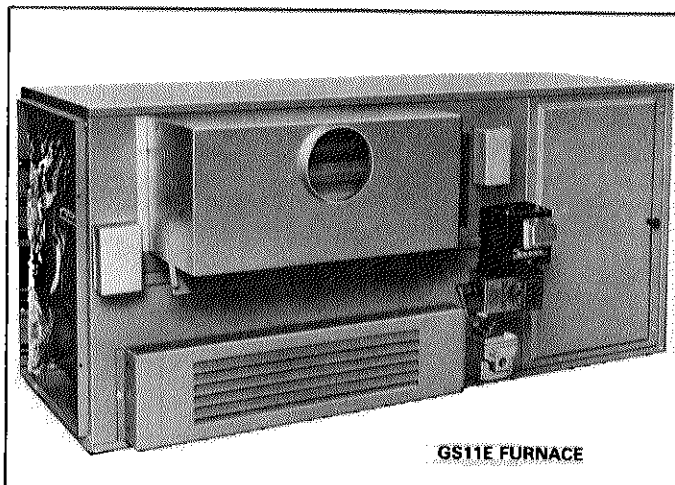

FIGURE 1

II - UNIT INFORMATION

A - Specifications

Model Number	GS11Q3E-60 & GS11Q3-60	GS11D2E-80 & GS11D2-80	GS11Q3E-80 & GS11Q3-80	GS11D2E-100 & GS11D2-100	GS11Q4E-100 & GS11Q4-100
Btuh input	60,000	80,000	80,000	100,000	100,000
Btuh output at bonnet	48,000	64,000	64,000	80,000	80,000
Vent size (in.)	4	5	5	5	5
A.G.A. certified high statics (in. wg.)	.50	.50	.50	.50	.50
Gas piping size (in.) (Nat. & Prop.)	1/2	1/2	1/2	1/2	1/2
Blower wheel nom. diam. x width (in.)	10 x 6	10 x 6	10 x 6	9 x 8	10 x 8
Blower motor horsepower	1/3	1/4	1/3	1/4	1/3
Tons of additive cooling	1-1/2, 2 or 2-1/2	1-1/2 or 2	2-1/2 or 3	2 or 2-1/2	3, 3-1/2 or 4
Shipping weight (lbs.) 1 Package	186	208	212	232	236
Electrical characteristics	120 volts — 60 hertz — 1 phase (all units)				
Optional Filter Adapter	Model No. FC3-60 Net weight (lbs.) 8	Model No. FC3-80 Net weight (lbs.) 10	Model No. FC3-80 Net weight (lbs.) 10	Model No. FC3-100 Net weight (lbs.) 12	Model No. FC3-100 Net weight (lbs.) 12
Optional Filter, no. & size (in.)	(1) 15 x 20 x 1	(1) 16 x 20 x 1	(1) 16 x 20 x 1	(1) 20 x 20 x 1	(1) 20 x 20 x 1

Model Number	GS11Q5E-120 & GS11Q5-120	GS11Q3E-140 & GS11Q3-140	GS11Q5E-140 & GS11Q5-140
Btuh input	120,000	140,000	140,000
Btuh output at bonnet	96,000	112,000	112,000
Vent size (in.)	5	6	6
A.G.A. certified high statics (in. wg.)	.50	.50	.50
Gas piping size (in.) (Nat. & Prop.)	1/2	1/2	1/2
Blower wheel nom. diam. x width (in.)	10 x 10	10 x 10	12 x 9
Blower motor horsepower	1/2	1/3	3/4
Tons of additive cooling	3, 3-1/2, 4 or 5	2-1/2 or 3	3-1/2, 4 or 5
Shipping weight (lbs.) (1 package)	263	289	308
Electrical characteristics	120 volts — 60 hertz — 1 phase (all units)		
Optional Filter Adapter	Model No. FC3-120 Net weight (lbs.) 13	Model No. FC3-140 Net weight (lbs.) 15	Model No. FC3-140 Net weight (lbs.) 15
Optional Filter(s), no. & size (in.)	(2) 15 x 20 x 1	(2) 15 x 20 x 1	(2) 15 x 20 x 1

B - Field Wiring (Figure 2)

Line voltage connections are made at unit junction box. Low voltage connections are made at terminal block at junction box. Accessories must never be wired through fan control since it is possible to generate approximately 180 volts. The motor acts as an auto transformer to generate the higher voltage. Accessories must be wired through an isolated cir-

cuit and may be interconnected to blower operation with a current sensing relay or sail switch.

C - Installation Considerations

Installation must conform with local codes or in absence of local codes, with the National Fuel Gas Code (ANSI-Z223.1-1974). Air supply for combustion and ventilation must conform to methods outlined in ANSI-Z223.1-1974.

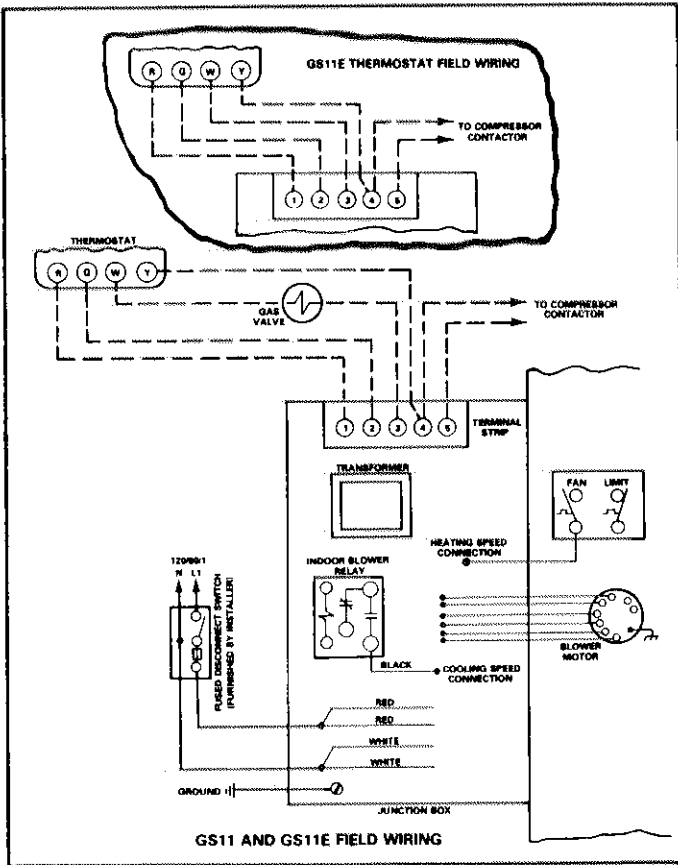

FIGURE 2

III - UNIT COMPONENTS

Figure 3 shows an exploded view of the unit.

1 - Combination Fan/Limit Control

On GS11 units the limit control is wired through the 120 volt circuit to de-energize the transformer at excessive unit temperatures. On GS11E the limit is wired through the "W" leg of thermostat to de-energize the control circuit at excessive temperatures. Do not alter limit setting. Fan control is adjustable.

2 - Upper Limit Control

On GS11E units this control is wired in series to the other limit. On GS11 units it is wired in series to the gas valve.

3 - Electronic Ignition Components (GS11E)

GS11E units use the Penn-Johnson ignition control system. Refer to appropriate section within this manual for additional information.

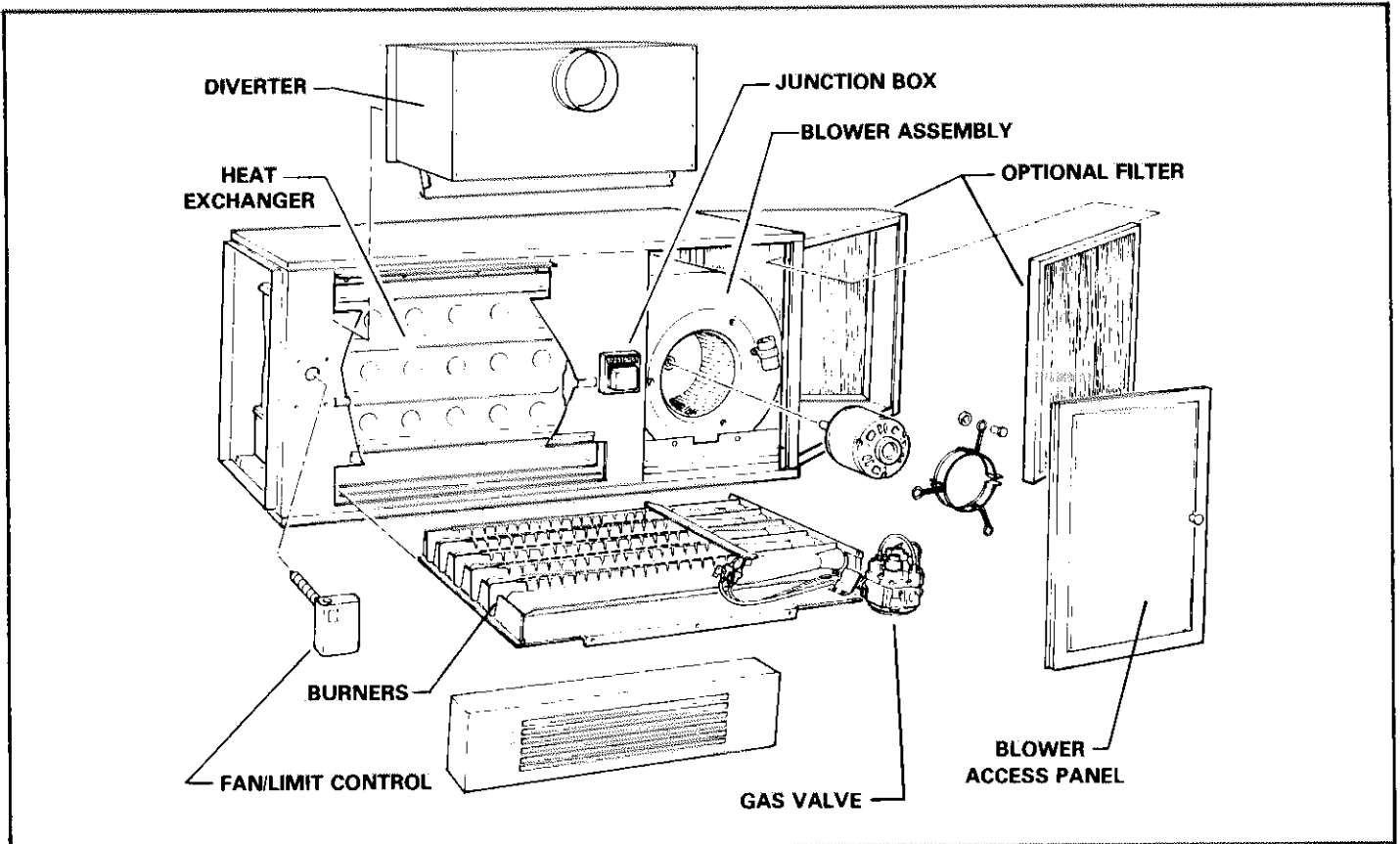

FIGURE 3

4 - Air Shutters

An air shutter assembly is provided on all furnaces. Shutters are factory set in mid position for natural gas. The shutters are linked to each adjacent burner. See Figure 4. Adjustments are made simultaneously on all the burners.

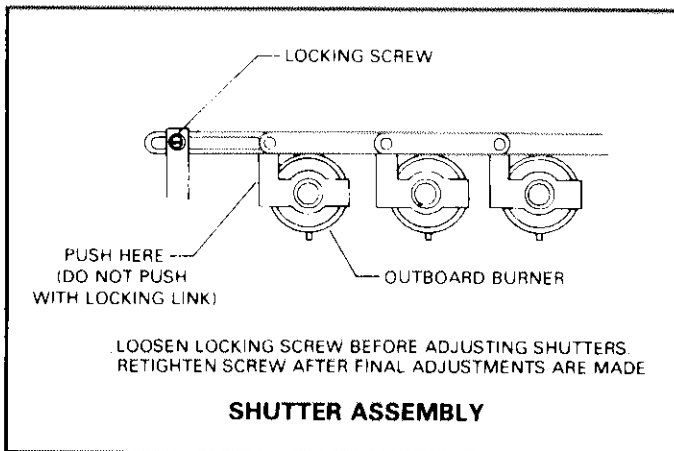

FIGURE 4

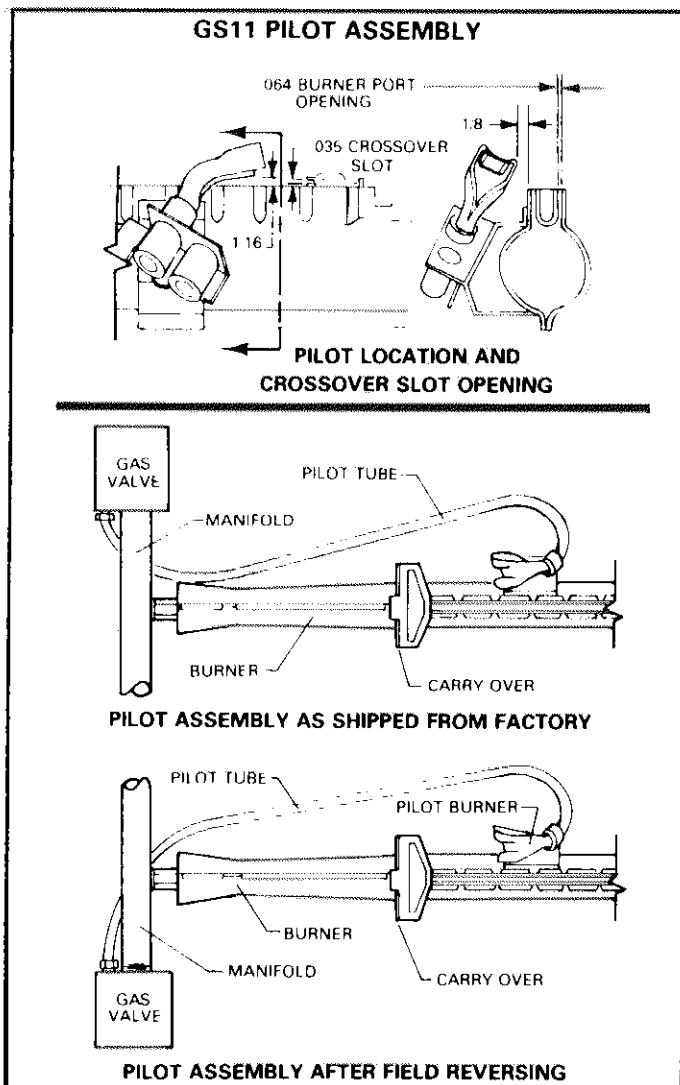

FIGURE 5

IV - PILOT ADJUSTMENT

During installation the gas valve and pilot burner components can be reversed if desired. Figure 5 gives GS11 pilot position, crossover dimensions and illustrates the pilot assembly.

Figure 6 illustrates pilot assembly dimensions as shipped from factory and after field reversing for GS11E units.

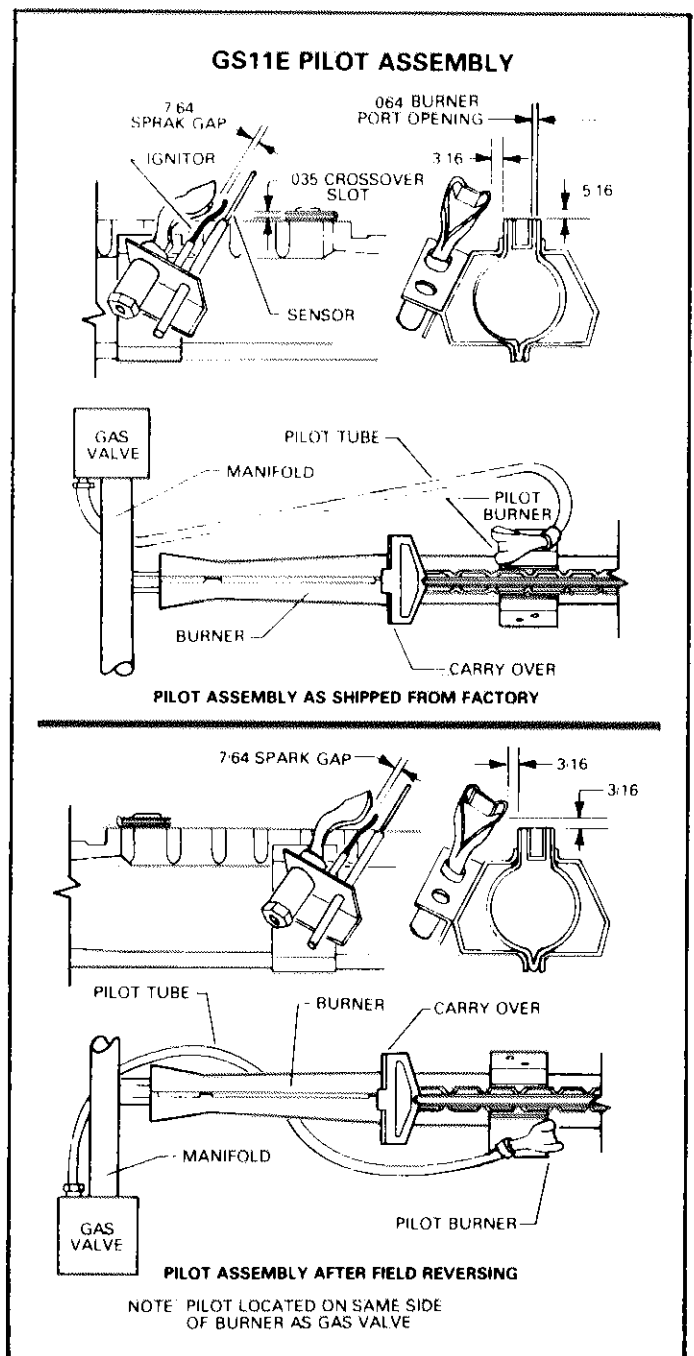

FIGURE 6

V - TEMPERATURE RISE

The blower speed must be set to meet the proper air temperature rise listed on unit rating plate. To measure this temperature rise, place plenum thermometers in warm air and return air plenums. Set thermostat to highest setting. After plenum thermometers have reached their highest and steadiest readings, subtract the two. The difference should

TABLE 1

BLOWER SPEED SELECTION

IMPORTANT TO PREVENT MOTOR BURNOUT NEVER CONNECT MORE THAN ONE MOTOR LEAD TO ANY ONE CONNECTION TAPE UNUSED MOTOR LEADS SEPARATELY

SPEED	BLOWER MOTOR LEAD		
	Q4	Q3	Q5
LOW	RED	RED	RED
MEDIUM LOW	YELLOW	YELLOW
MEDIUM	YELLOW	BLUE
MEDIUM HI	BROWN	BROWN
HIGH	BLACK	BLACK	BLACK

be in the range listed on unit rating plate. If this temperature is low decrease blower speed; if temperature is high increase blower speed. Table 1 shows the speed selection charts for the various units.

VI - SCHEMATIC WIRING DIAGRAM OPERATING SEQUENCE

Figure 7 illustrates a typical GS11. See Penn-Johnson section for a GS11E.

TYPICAL GS11 SEQUENCE OF OPERATION

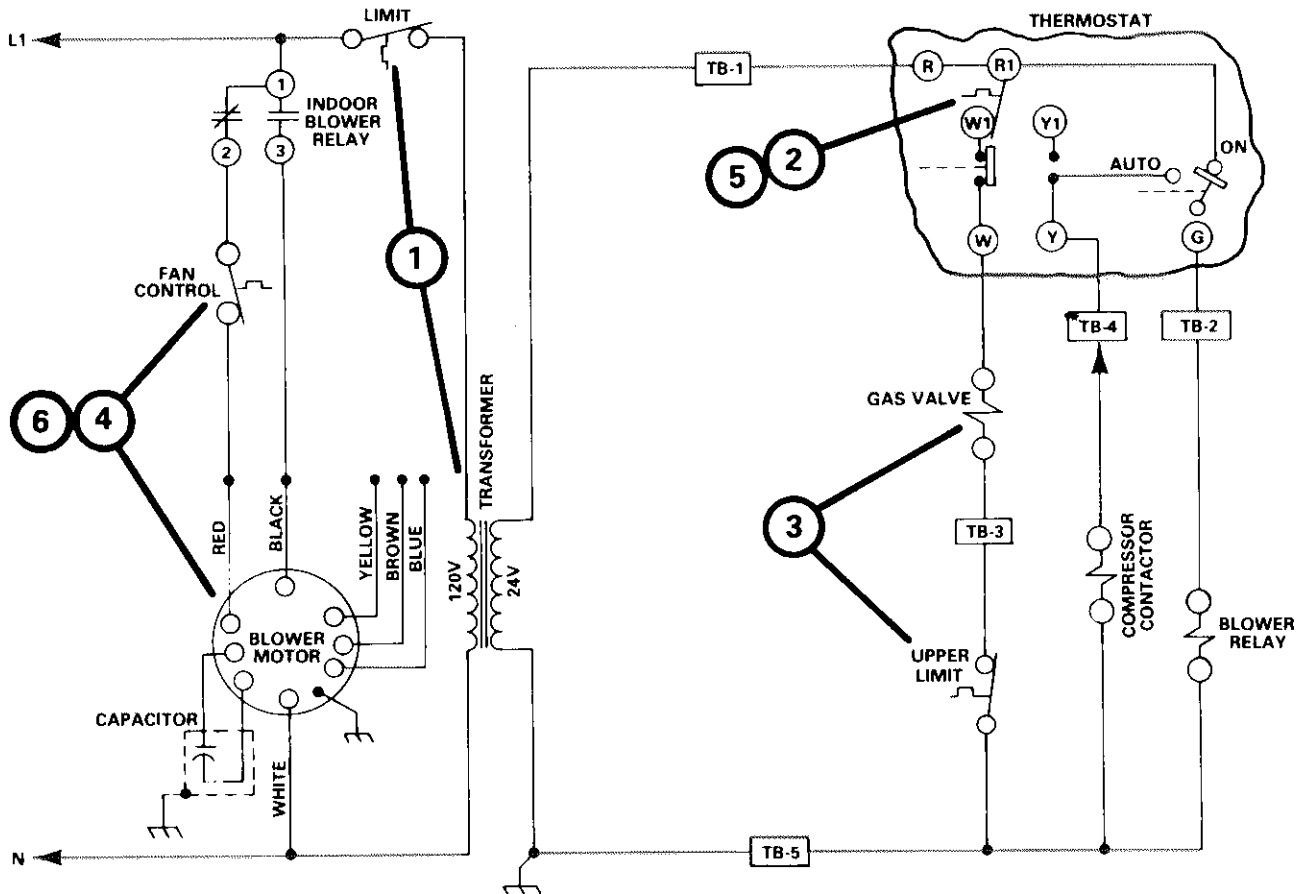

- 1 - Line potential feeds through limit to power transformer and provide the 24 volt control circuit.
- 2 - On a heating demand the thermostat heating bulb makes.
- 3 - This energizes the gas valve providing the upper limit is closed and the gas valve is not locked out because of loss of pilot. Main burners are ignited.

- 4 - The fan control makes after temperature rises above cut-in setpoint. The blower motor is energized at heating speed.
- 5 - As heating demand is satisfied, the thermostat heating bulb breaks. This de-energizes the gas valve.
- 6 - The blower motor continues running until furnace temperature drops below fan control setpoint.

FIGURE 7