

XP14 (HFC-410A) SERIES UNITS



TABLE OF CONTENTS

Model Number Identification	2
Typical Serial Number Identification	2
Specifications	2
Electrical Data	4
Unit Dimensions	5
Unit Parts Arrangement	6
Operating Gauge Set and Service Valves	7
Recovering Refrigerant from System	9
Unit Placement	10
Removing and Installing Panels	12
New or Replacement Line Set	14
Brazing Connections	16
Flushing Line Set and Indoor Coil	19
Installing Indoor Metering Device	20
Leak Test Line Set and Indoor Coil	21
Evacuating Line Set and Indoor Coil	22
Electrical	23
Servicing Units Void of Charge	24
Unit Start-Up	24
System Refrigerant	24
System Operation	29
Defrost System	31
Maintenance	34
Start-up and Performance Checklist	36
Unit Wiring Diagram and Sequence of Operations	35

The XP14 is a high efficiency residential split-system heat pump unit, which features a scroll compressor and HFC-410A refrigerant. XP14 units are available in sizes ranging from 1-1/2 through 5 tons. The series is designed for use with an indoor unit with an check expansion valve approved for HFC-410A.

⚠ WARNING

Improper installation, adjustment, alteration, service or maintenance can cause personal injury, loss of life, or damage to property.

Installation and service must be performed by a licensed professional installer (or equivalent) or a service agency.

⚠ CAUTION

Physical contact with metal edges and corners while applying excessive force or rapid motion can result in personal injury. Be aware of, and use caution when working near these areas during installation or while servicing this equipment.

⚠ IMPORTANT

The Clean Air Act of 1990 bans the intentional venting of refrigerant (CFCs, HCFCs and HFCs) as of July 1, 1992. Approved methods of recovery, recycling or reclaiming must be followed. Fines and/or incarceration may be levied for noncompliance.

⚠ IMPORTANT

This unit must be matched with an indoor coil as specified in *Lennox XP14 Engineering Handbook*. Coils previously charged with HCFC-22 must be flushed.

Model Number Identification

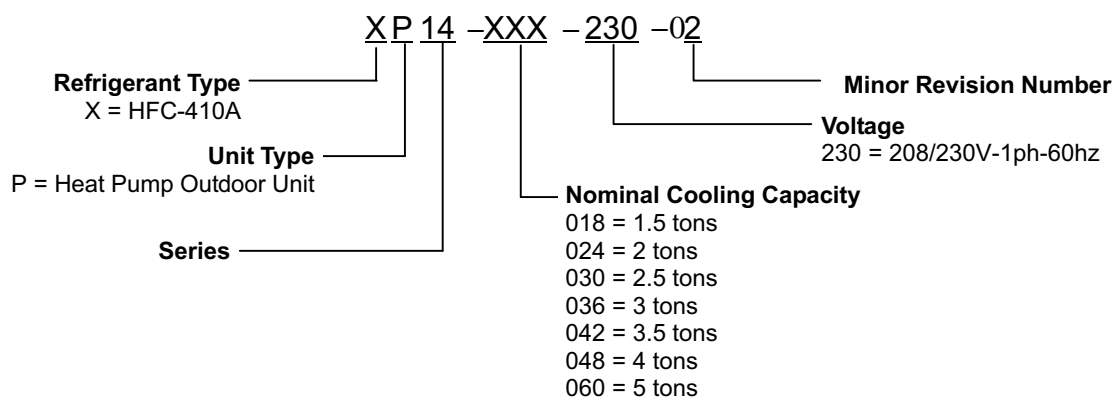

Typical Serial Number Identification

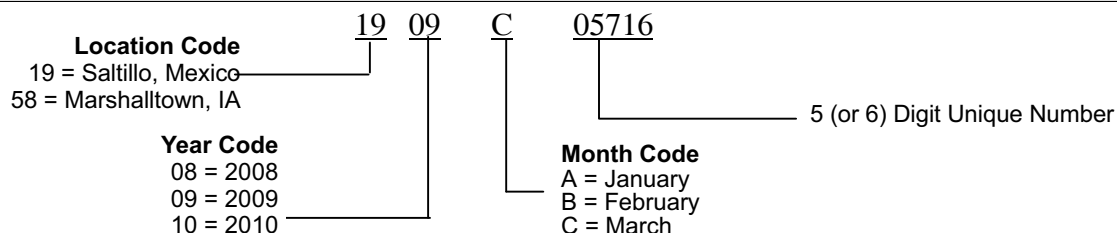

Specifications

Model Number	Unit		Outdoor Fan	
	Sound Rating Number (dB) ¹	Factory Refrigerant Charge ²	Number of Blades	Diameter - inches.
XP14-018-230-01	71	8 lbs. 4 oz.	3	18
XP14-018-230-02	71	8 lbs. 4 oz.	3	18
XP14-018-230-03	71	8 lbs. 4 oz.	3	18

Model Number	Unit		Outdoor Fan	
	Sound Rating Number (dB) ¹	Factory Refrigerant Charge ²	Number of Blades	Diameter - inches.
XP14-024-230-01	71	8 lbs. 0 oz.	3	18
XP14-024-230-02	71	8 lbs. 0 oz.	3	18
XP14-024-230-03	71	8 lbs. 0 oz.	3	18

Model Number	Unit		Outdoor Fan	
	Sound Rating Number (dB) ¹	Factory Refrigerant Charge ²	Number of Blades	Diameter - inches.
XP14-030-230-01	71	7 lbs. 2 oz.	3	18
XP14-030-230-02	71	7 lbs. 2 oz.	3	18
XP14-030-230-03	71	7 lbs. 2 oz.	3	18

Model Number	Unit		Outdoor Fan	
	Sound Rating Number (dB) ¹	Factory Refrigerant Charge ²	Number of Blades	Diameter - inches.
XP14-036-230-01	71	9 lbs. 12 oz.	4	26
XP14-036-230-02	71	9 lbs. 12 oz.	4	26

Model Number	Unit		Outdoor Fan	
	Sound Rating Number (dB) ¹	Factory Refrigerant Charge ²	Number of Blades	Diameter - inches.
XP14-042-230-01	71	12 lbs. 7 oz.	4	26
XP14-042-230-02	71	12 lbs. 7 oz.	4	26

Model Number	Unit		Outdoor Fan	
	Sound Rating Number (dB) ¹	Factory Refrigerant Charge ²	Number of Blades	Diameter - inches.
XP14-048-230-01	73	12 lbs. 10 oz.	4	26
XP14-048-230-02	73	12 lbs. 10 oz.	4	26

Model Number	Unit		Outdoor Fan	
	Sound Rating Number (dB) ¹	Factory Refrigerant Charge ²	Number of Blades	Diameter - inches.
XP14-060-230-01	73	16 lbs. 0 oz.	4	26
XP14-060-230-02	73	16 lbs. 0 oz.	4	26

¹ Tested according to AHRI Standard 270-2008 test conditions.

² Refrigerant charge sufficient for 15 feet length of refrigerant lines.

Electrical Data

208/230V-60 Hz-1 Ph

Model Number	Unit		Compressor		Condenser Fan			
	Maximum Over-current Protection (amps) ¹	Minimum Circuitry Ampacity ²	Rated Load Amps (RLA)	Locked Rotor Amps (LRA)	Motor HP	Nominal RPM	Full Load Amps (FLA)	Locked Rotor Amps (LRA)
XP14-018-230-01	20	11.9	8.97	48.0	1/10	1075	0.7	1.4
XP14-018-230-02	20	11.9	8.97	48.0	1/10	1075	0.7	1.4
XP14-018-230-03	20	11.9	8.97	48.0	1/10	1075	0.7	1.4

208/230V-60 Hz-1 Ph

Model Number	Unit		Compressor		Condenser Fan			
	Maximum Over-current Protection (amps) ¹	Minimum Circuitry Ampacity ²	Rated Load Amps (RLA)	Locked Rotor Amps (LRA)	Motor HP	Nominal RPM	Full Load Amps (FLA)	Locked Rotor Amps (LRA)
XP14-024-230-01	30	17.5	13.46	58.0	1/10	1075	0.7	1.4
XP14-024-230-02	30	17.5	13.46	58.0	1/10	1075	0.7	1.4
XP14-024-230-03	30	17.5	13.46	58.0	1/10	1075	0.7	1.4

208/230V-60 Hz-1 Ph

Model Number	Unit		Compressor		Condenser Fan			
	Maximum Over-current Protection (amps) ¹	Minimum Circuitry Ampacity ²	Rated Load Amps (RLA)	Locked Rotor Amps (LRA)	Motor HP	Nominal RPM	Full Load Amps (FLA)	Locked Rotor Amps (LRA)
XP14-036-230-01	30	19.4	14.1	77.0	1/3	825	1.8	2.9
XP14-036-230-02	30	19.4	14.1	77.0	1/3	825	1.8	2.9

208/230V-60 Hz-1 Ph

Model Number	Unit		Compressor		Condenser Fan			
	Maximum Over-current Protection (amps) ¹	Minimum Circuitry Ampacity ²	Rated Load Amps (RLA)	Locked Rotor Amps (LRA)	Motor HP	Nominal RPM	Full Load Amps (FLA)	Locked Rotor Amps (LRA)
XP14-042-230-01	40	24.2	17.94	112.0	1/3	825	1.8	2.9
XP14-042-230-02	40	24.2	17.94	112.0	1/3	825	1.8	2.9

208/230V-60 Hz-1 Ph

Model Number	Unit		Compressor		Condenser Fan			
	Maximum Over-current Protection (amps) ¹	Minimum Circuitry Ampacity ²	Rated Load Amps (RLA)	Locked Rotor Amps (LRA)	Motor HP	Nominal RPM	Full Load Amps (FLA)	Locked Rotor Amps (LRA)
XP14-048-230-01	50	29.0	21.79	117.0	1/3	825	1.8	2.1
XP14-048-230-02	50	29.0	21.79	117.0	1/3	825	1.8	2.1

208/230V-60 Hz-1 Ph

Model Number	Unit		Compressor		Condenser Fan			
	Maximum Over-current Protection (amps) ¹	Minimum Circuitry Ampacity ²	Rated Load Amps (RLA)	Locked Rotor Amps (LRA)	Motor HP	Nominal RPM	Full Load Amps (FLA)	Locked Rotor Amps (LRA)
XP14-060-230-01	60	34.8	26.41	134.0	1/3	825	1.8	2.1
XP14-060-230-02	60	34.8	26.41	134.0	1/3	825	1.8	2.1

¹ HACR type circuit breaker or fuse.

² Refer to National or Canadian Electrical Code manual to determine wire, fuse and disconnect size requirements.

Unit Dimensions - Inches (mm)

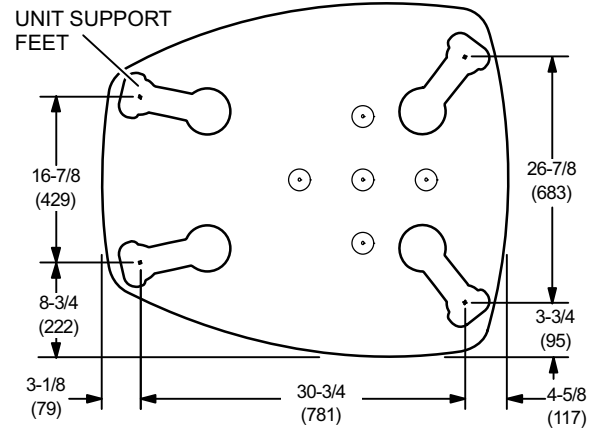
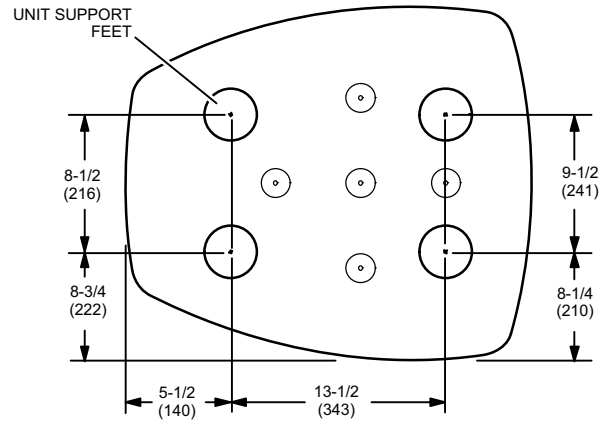
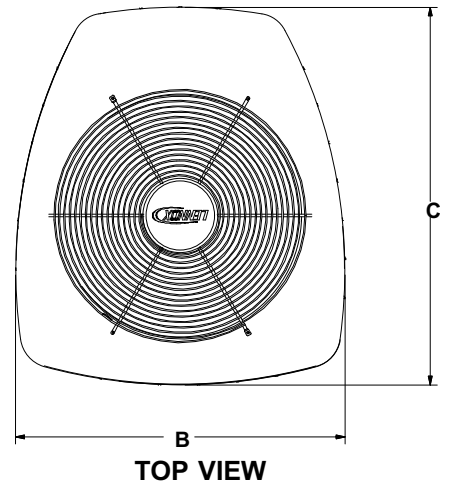
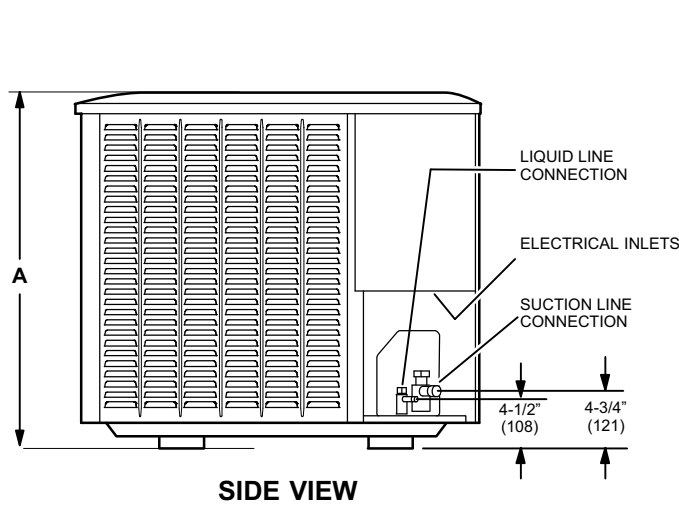

Model Number	A	B	C
XC14-018-230-XX (All)	31 (787)	27 (686)	28 (711)
XC14-024-230-XX (All)	31 (787)	27 (686)	28 (711)
XC14-030-230-XX (All)	35 (889)	27 (686)	28 (711)
XC14-036-230-XX (All)	31 (787)	35-1/2 (902)	39-1/2 (1003)
XC14-042-230-XX and XC14-048-230-XX (All)	39 (991)	35-1/2 (902)	39-1/2 (1003)
XC14-060-230-XX (All)	45 (1143)	35-1/2 (902)	39-1/2 (1003)

Typical Unit Parts Arrangement

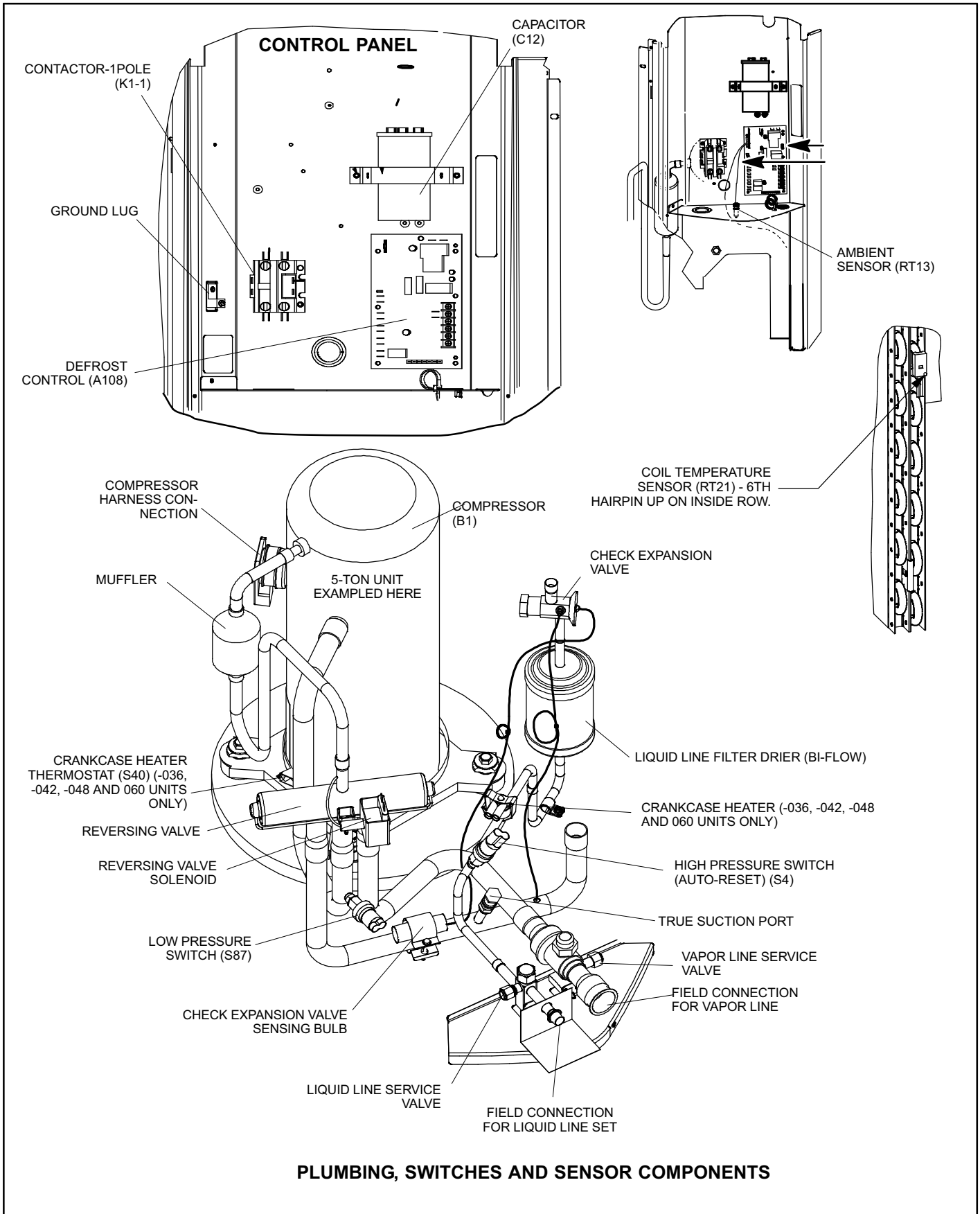

Figure 1. Typical Parts Arrangements

WARNING

This product and/or the indoor unit it is matched with may contain fiberglass wool.

Disturbing the insulation during installation, maintenance, or repair will expose you to fiberglass wool dust. Breathing this may cause lung cancer. (Fiberglass wool is known to the State of California to cause cancer.)

Fiberglass wool may also cause respiratory, skin, and eye irritation.

To reduce exposure to this substance or for further information, consult material safety data sheets available from address shown below, or contact your supervisor.

Lennox Industries Inc.
P.O. Box 799900
Dallas, TX 75379-9900

IMPORTANT

Only use Allen wrenches of sufficient hardness (50Rc - Rockwell Harness Scale minimum). Fully insert the wrench into the valve stem recess.

Service valve stems are factory-torqued (from 9 ft-lbs for small valves, to 25 ft-lbs for large valves) to prevent refrigerant loss during shipping and handling. Using an Allen wrench rated at less than 50Rc risks rounding or breaking off the wrench, or stripping the valve stem recess.

See the Lennox Service and Application Notes #C-08-1 for further details and information.

IMPORTANT

To prevent stripping of the various caps used, the appropriately sized wrench should be used and fitted snugly over the cap before tightening.

WARNING



Electric Shock Hazard. Can cause injury or death. Unit must be grounded in accordance with national and local codes.

Line voltage is present at all components when unit is not in operation on units with single-pole contactors. Disconnect all remote electric power supplies before opening access panel. Unit may have multiple power supplies.

Operating Gauge Set and Service Valves

These instructions are intended as a general guide and do not supersede local codes in any way. Consult authorities who have jurisdiction before installation.

TORQUE REQUIREMENTS

When servicing or repairing heating, ventilating, and air conditioning components, ensure the fasteners are appropriately tightened. Table 1 lists torque values for fasteners.

Table 1. Torque Requirements

Parts	Recommended Torque	
Service valve cap	8 ft.- lb.	11 NM
Sheet metal screws	16 in.- lb.	2 NM
Machine screws #10	28 in.- lb.	3 NM
Compressor bolts	90 in.- lb.	10 NM
Gauge port seal cap	8 ft.- lb.	11 NM

USING MANIFOLD GAUGE SET

When checking the system charge, only use a manifold gauge set that features low loss anti-blow back fittings.

Manifold gauge set used with HFC-410A refrigerant systems must be capable of handling the higher system operating pressures. The gauges should be rated for use with pressures of 0 - 800 psig on the high side and a low side of 30" vacuum to 250 psig with dampened speed to 500 psi. Gauge hoses must be rated for use at up to 800 psig of pressure with a 4000 psig burst rating.

OPERATING SERVICE VALVES

The liquid and vapor line service valves are used for removing refrigerant, flushing, leak testing, evacuating, checking charge and charging.

Each valve is equipped with a service port which has a factory-installed valve stem. Figure 2 provides information on how to access and operating both angle and ball service valves.

SERVICE VALVES ANGLE AND BALL

Operating Angle Type Service Valve:

1. Remove stem cap with an appropriately sized wrench.
2. Use a service wrench with a hex-head extension (3/16" for liquid line valve sizes and 5/16" for vapor line valve sizes) to back the stem out counterclockwise as far as it will go.

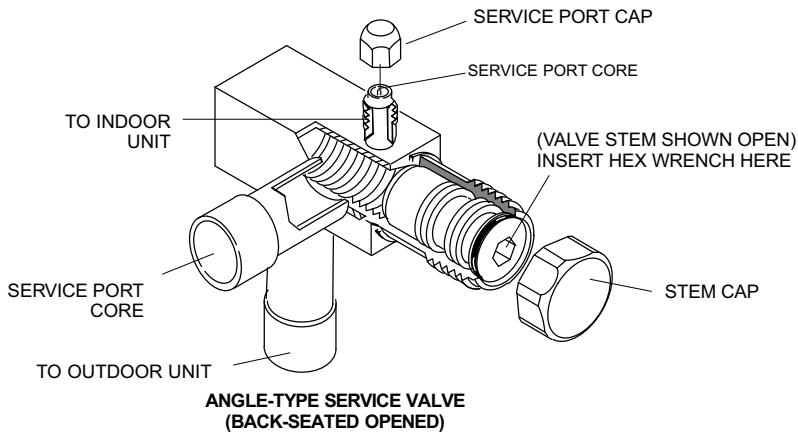

When service valve is **OPEN**, the service port is open to line set, indoor and outdoor unit.

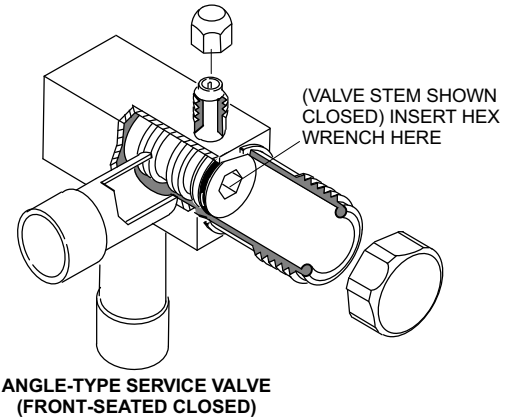

WHEN SERVICE VALVE IS **CLOSED**, THE SERVICE PORT IS OPEN TO THE LINE SET AND INDOOR UNIT.

Operating Ball Type Service Valve:

1. Remove stem cap with an appropriately sized wrench.
2. Use an appropriately sized wrench to open. To open valve, rotate stem counterclockwise 90°. To close rotate stem clockwise 90°.

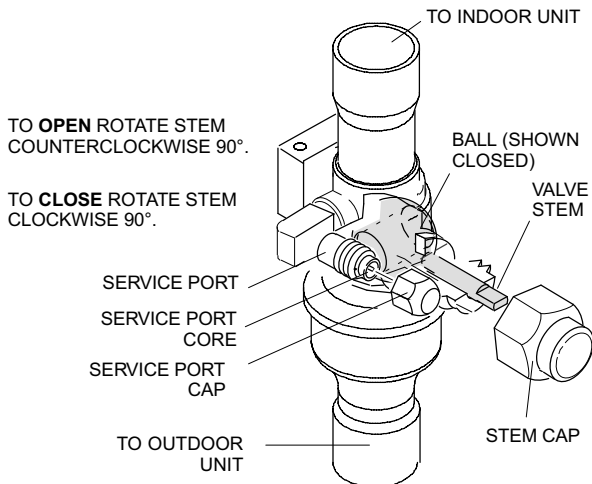

To Access Service Port:

A service port cap protects the service port core from contamination and serves as the primary leak seal.

1. Remove service port cap with an appropriately sized wrench.
2. Connect gauge set to service port.
3. When testing is completed, replace service port cap and tighten as follows:
 - With torque wrench: Finger tighten and torque cap per table 1.
 - Without torque wrench: Finger tighten and use an appropriately sized wrench to turn an additional 1/6 turn clockwise.

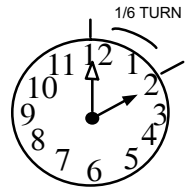

Reinstall Stem Cap:

Stem cap protects the valve stem from damage and serves as the primary seal. Replace the stem cap and tighten as follows:

- With Torque Wrench: Finger tighten and then torque cap per table 1.
- Without Torque Wrench: Finger tighten and use an appropriately sized wrench to turn an additional 1/12 turn clockwise.

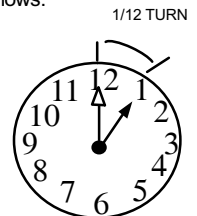

NOTE — A label with specific torque requirements may be affixed to the stem cap. If the label is present, use the specified torque.

Figure 2. Angle and Ball Service Valves

Recovering Refrigerant from System

1 DISCONNECT POWER

Disconnect all power to the existing outdoor unit at the disconnect switch or main fuse box/breaker panel.

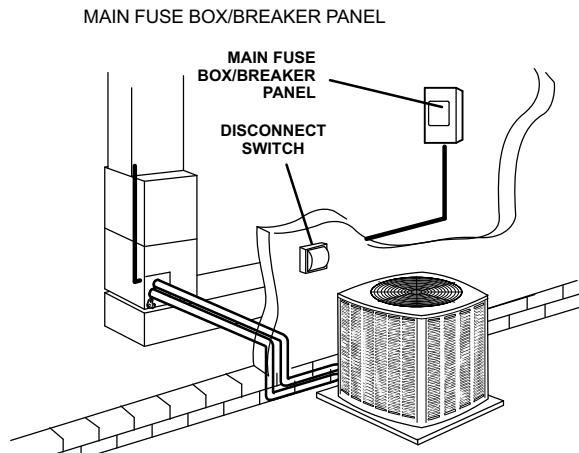

2 CONNECT MANIFOLD GAUGE SET

Connect a gauge set, clean recovery cylinder and a recovery machine to the service ports of the existing unit. Use the instructions provided with the recovery machine to make the connections.

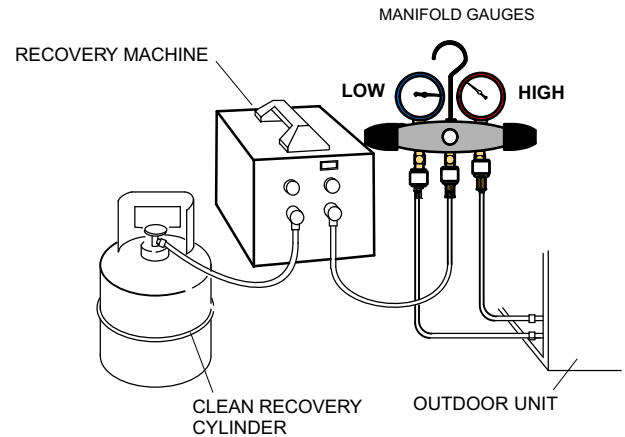

3 RECOVERING REFRIGERANT

Remove existing HCFC-22 refrigerant using one of the following procedures:

IMPORTANT — Some system configurations may contain higher than normal refrigerant charge due to either large internal coil volumes, and/or long line sets.

METHOD 1:

Use this method if the existing outdoor unit is not equipped with shut-off valves, or if the unit is not operational and you plan to use the existing HCFC-22 to flush the system.

Remove all HCFC-22 refrigerant from the existing system. Check gauges after shutdown to confirm that the entire system is completely void of refrigerant.

METHOD 2:

Use this method if the existing outdoor unit is equipped with manual shut-off valves, and you plan to use new HCFC-22 refrigerant to flush the system.

The following devices could prevent full system charge recovery into the outdoor unit:

- Outdoor unit's high or low-pressure switches (if applicable) when tripped can cycle the compressor **OFF**.
- Compressor can stop pumping due to tripped internal pressure relief valve.
- Compressor has internal vacuum protection that is designed to unload the scrolls (compressor stops pumping) when the pressure ratio meets a certain value or when the suction pressure is as high as 20 psig. (Compressor suction pressures should never be allowed to go into a vacuum. Prolonged operation at low suction pressures will result in overheating of the scrolls and permanent damage to the scroll tips, drive bearings and internal seals.)

Once the compressor can not pump down to a lower pressure due to one of the above system conditions, shut off the vapor valve. Turn OFF the main power to unit and use a recovery machine to recover any refrigerant left in the indoor coil and line set.

Perform the following task:

- A Start the existing HCFC-22 system in the cooling mode and close the liquid line valve.
- B Use the compressor to pump as much of the existing HCFC-22 refrigerant into the outdoor unit until the outdoor system is full. Turn the outdoor unit main power OFF and use a recovery machine to remove the remaining refrigerant from the system.

NOTE — It may be necessary to bypass the low pressure switches (if equipped) to ensure complete refrigerant evacuation.

- C When the low side system pressures reach 0 psig, close the vapor line valve.
- D Check gauges after shutdown to confirm that the valves are not allowing refrigerant to flow back into the low side of the system.

Figure 3. Refrigerant Recovery

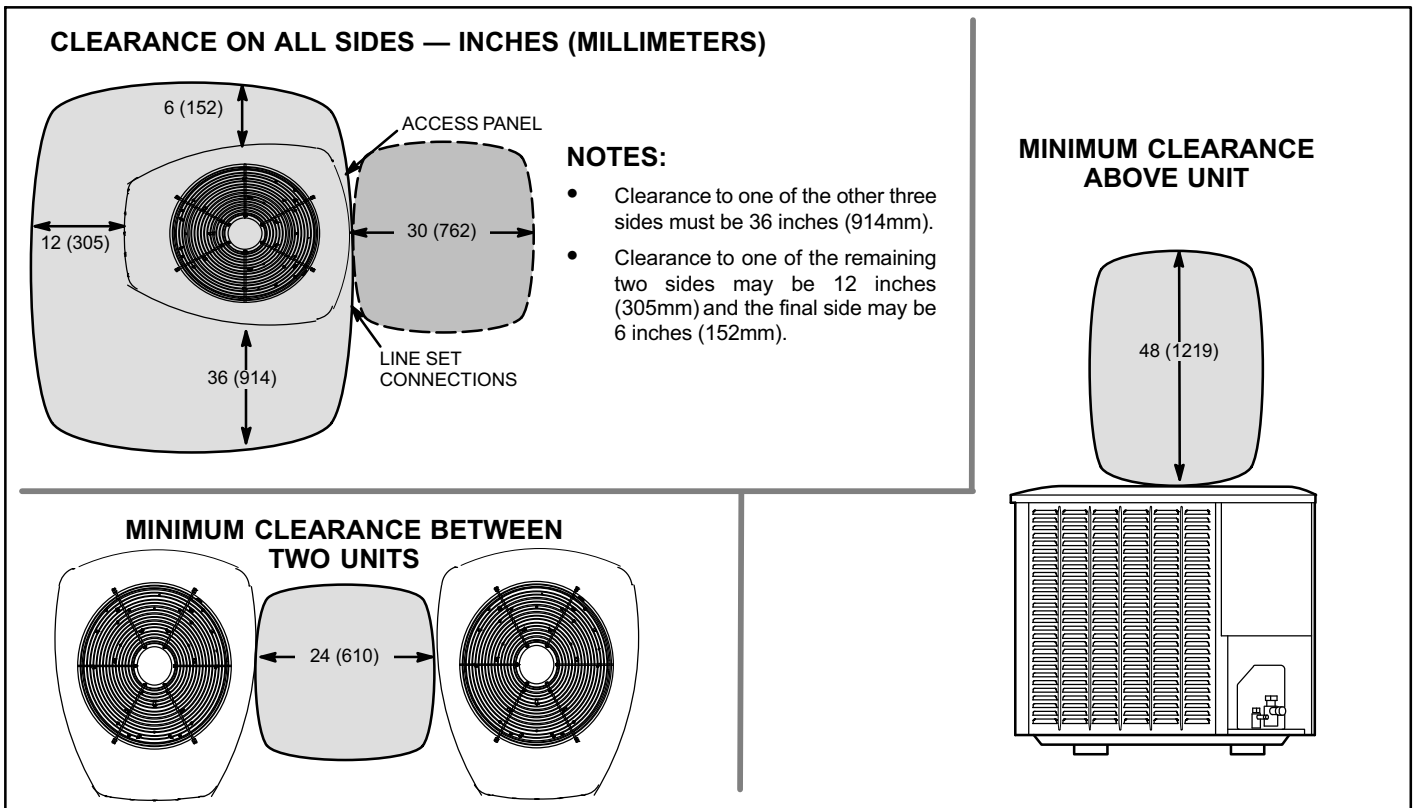

Figure 4. Installation Clearances

Unit Placement

⚠ CAUTION

In order to avoid injury, take proper precaution when lifting heavy objects.

See *Unit Dimensions* on page 3 for sizing mounting slab, platforms or supports. Refer to figure 4 for mandatory installation clearance requirements.

POSITIONING CONSIDERATIONS

Consider the following when positioning the unit:

- Some localities are adopting sound ordinances based on the unit's sound level registered from the adjacent property, not from the installation property. Install the unit as far as possible from the property line.
- When possible, do not install the unit directly outside a window. Glass has a very high level of sound transmission. For proper placement of unit in relation to a window see the provided illustration in figure 5, detail A.

PLACING UNIT ON SLAB

When installing unit at grade level, the top of the slab should be high enough above grade so that water from higher ground will not collect around the unit. The slab should have a slope tolerance as described in figure 5, detail B.

NOTE — If necessary for stability, anchor unit to slab as described in figure 5, detail D.

ELEVATING THE UNIT

Units are outfitted with elongated support feet as illustrated in figure 5, detail C.

If additional elevation is necessary, raise the unit by extending the height of the unit support feet. This may be achieved by using a 2 inch (50.8mm) Schedule 40 female threaded adapter.

The specified coupling will fit snugly into the recessed portion of the feet. Use additional 2 inch (50.8mm) Schedule 40 male threaded adaptors which can be threaded into the female threaded adaptors to make additional adjustments to the level of the unit.

NOTE — Keep the height of extenders short enough to ensure a sturdy installation. If it is necessary to extend further, consider a different type of field-fabricated framework that is sturdy enough for greater heights.

DETAIL A— Outside Unit Placement

Install unit away from windows.

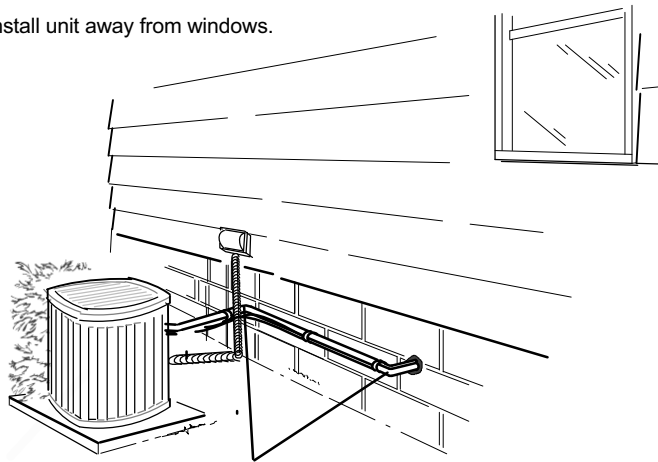

TWO 90° ELBOWS INSTALLED IN LINE SET WILL REDUCE LINE SET VIBRATION.

DETAIL B— Slab Mounting at Ground Level

Install unit level or, if on a slope, maintain slope tolerance of two (2) degrees (or two inches per five feet [50 mm per 1.5 m]) away from building structure.

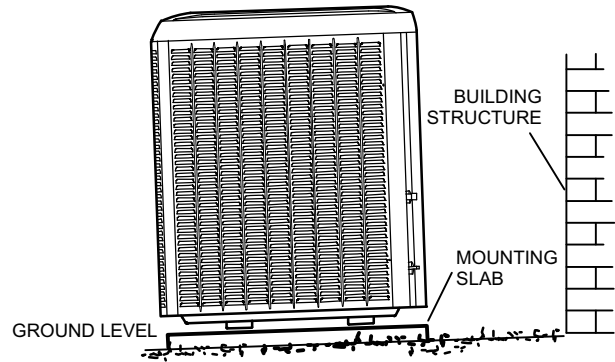

DETAIL C— Elevated Slab Mounting using Feet Extenders

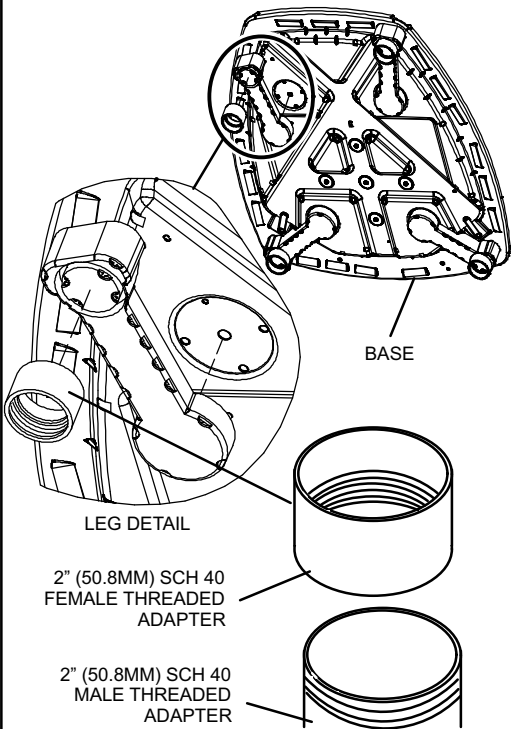

Use additional 2" SCH 40 male threaded adapters which can be threaded into the female threaded adapters to make additional adjustments to the level of the unit.

STABILIZING UNIT ON UNEVEN SURFACES

DETAIL D— Slab Side Mounting

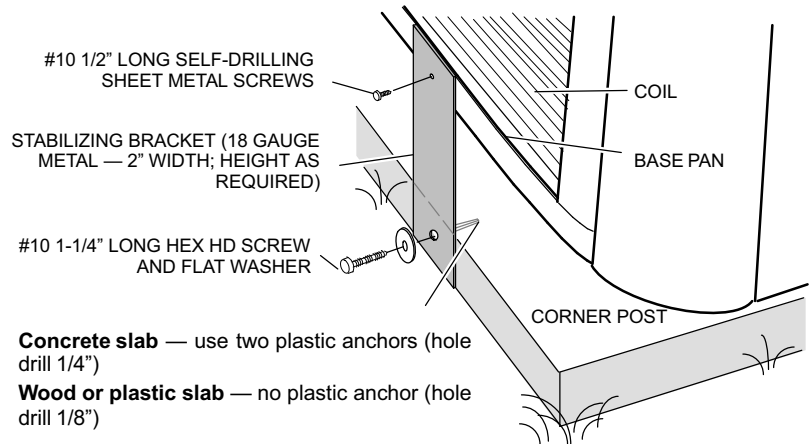

Concrete slab — use two plastic anchors (hole drill 1/4")

Wood or plastic slab — no plastic anchor (hole drill 1/8")

DETAIL E— Deck Top Mounting

Stabilizing bracket (18 gauge metal — 2" (50.8mm) width; height as required); bend to form right angle as exemplified below.

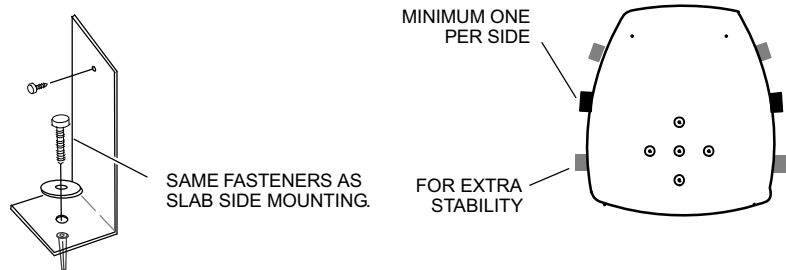

One bracket per side (minimum). For extra stability, two brackets per side, two inches (51mm) from each corner.

IMPORTANT — To help stabilize an outdoor unit, some installations may require strapping the unit to the pad using brackets and anchors commonly available in the marketplace.

Figure 5. Placement, Slab Mounting and Stabilizing Unit

STABILIZING UNIT ON UNEVEN SURFACES

IMPORTANT

Unit Stabilizer Bracket Use (field-provided):

Always use stabilizers when unit is raised above the factory height. (Elevated units could become unstable in gusty wind conditions).

Stabilizers may be used on factory height units when mounted on unstable an uneven surface.

With unit positioned at installation site, perform the following:

1. Remove two side louvered panels to expose the unit base.
2. Install the brackets as illustrated in figure 5, detail D or E using conventional practices.
3. Replace the panels after installation is complete.

ROOF MOUNTING

Install the unit a minimum of 6 inches (152 mm) above the roof surface to avoid ice build-up around the unit. Locate the unit above a load bearing wall or area of the roof that can adequately support the unit. Consult local codes for rooftop applications.

If unit coil cannot be mounted away from prevailing winter winds, a wind barrier should be constructed. Size barrier at least the same height and width as outdoor unit. Mount barrier 24 inches (610 mm) from the sides of the unit in the direction of prevailing winds.

NOTICE

Roof Damage!

This system contains both refrigerant and oil. Some rubber roofing material may absorb oil and cause the rubber to swell when it comes into contact with oil. The rubber will then bubble and could cause leaks. Protect the roof surface to avoid exposure to refrigerant and oil during service and installation. Failure to follow this notice could result in damage to roof surface.

Removing and Installing Panels

IMPORTANT

Do not allow panels to hang on unit by top tab. Tab is for alignment and not designed to support weight of panel.

IMPORTANT

To help stabilize an outdoor unit, some installations may require strapping the unit to the pad using brackets and anchors commonly available in the marketplace.

WARNING

To prevent personal injury, or damage to panels, unit or structure, be sure to observe the following:

While installing or servicing this unit, carefully stow all removed panels out of the way, so that the panels will not cause injury to personnel, nor cause damage to objects or structures nearby, nor will the panels be subjected to damage (e.g., being bent or scratched).

While handling or stowing the panels, consider any weather conditions, especially windy conditions, that may cause panels to be blown around and battered.

LOUVERED PANEL REMOVAL

Remove the louvered panels as follows:

1. Remove two screws, allowing the panel to swing open slightly.
2. Hold the panel firmly throughout this procedure. Rotate bottom corner of panel away from hinged corner post until lower three tabs clear the slots as illustrated in **detail B**.
3. Move panel down until lip of upper tab clears the top slot in corner post as illustrated in **detail A**.

LOUVERED PANEL INSTALLATION

Position the panel almost parallel with the unit as illustrated in **detail D** with the screw side as close to the unit as possible.

Then, in a continuous motion:

1. Slightly rotate and guide the lip of top tab inward as illustrated in **detail A** and **C**; then upward into the top slot of the hinge corner post.
2. Rotate panel to vertical to fully engage all tabs.
3. Holding the panel's hinged side firmly in place, close the right-hand side of the panel, aligning the screw holes.
4. When panel is correctly positioned and aligned, insert the screws and tighten.

Detail C

MAINTAIN MINIMUM PANEL ANGLE (AS CLOSE TO PARALLEL WITH THE UNIT AS POSSIBLE) WHILE INSTALLING PANEL.

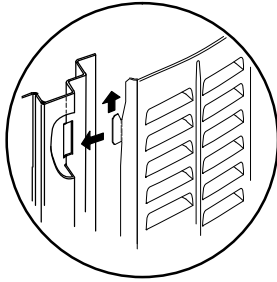

IMPORTANT! DO NOT ALLOW PANELS TO HANG ON UNIT BY TOP TAB. TAB IS FOR ALIGNMENT AND NOT DESIGNED TO SUPPORT WEIGHT OF PANEL.

PANEL SHOWN SLIGHTLY ROTATED TO ALLOW TOP TAB TO EXIT (OR ENTER) TOP SLOT FOR REMOVING (OR INSTALLING) PANEL.

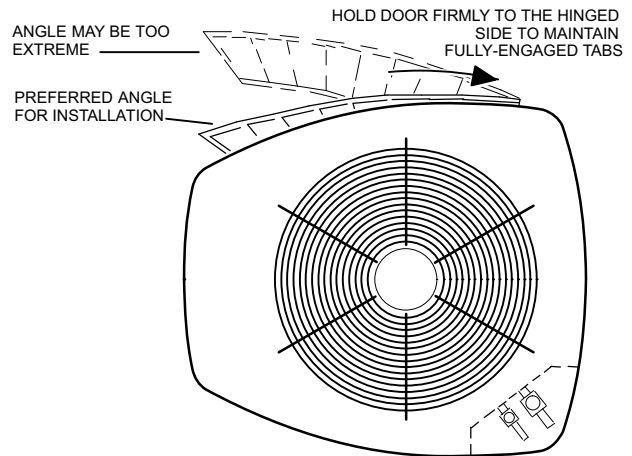
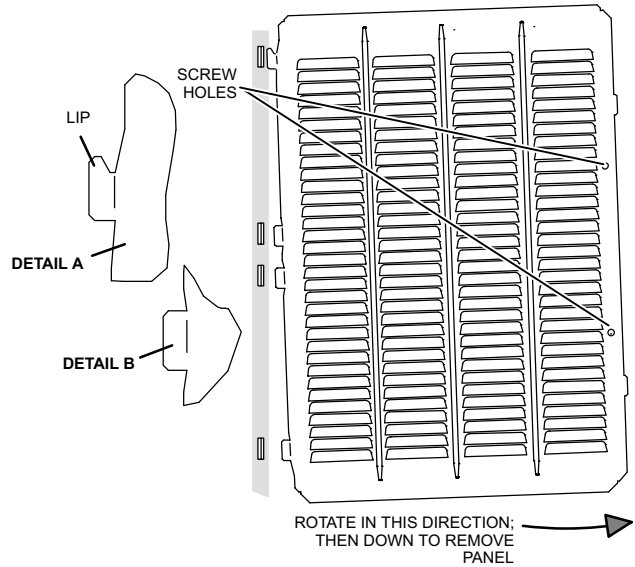

Figure 6. Removing and Installing Panels

New or Replacement Line Set

REFRIGERANT LINE SET

This section provides information on installation or replacement of existing line set. If new or replacement line set is not being installed then proceed to *Brazing Connections* on page 16.

IMPORTANT

Lennox highly recommends changing line set when converting the existing system from HCFC-22 to HFC-410A. If that is not possible and the line set is the proper size as reference in table 2, use the procedure outlined under *Flushing the System* on page 13.

If refrigerant lines are routed through a wall, then seal and isolate the opening so vibration is not transmitted to the building. Pay close attention to line set isolation during installation of any HVAC system. When properly isolated from building structures (walls, ceilings, floors), the refrigerant lines will not create unnecessary vibration and subsequent sounds. See figure 7 for recommended installation practices. Also, consider the following when placing and installing a high-efficiency outdoor unit.

Liquid lines that meter the refrigerant, such as RFC1 liquid lines, must not be used in this application. Existing line set of proper size as listed in table 2 may be reused. If system was previously charged with HCFC-22 refrigerant, then existing line set must be flushed (see *Flushing the System* on page 19).

Field refrigerant piping consists of liquid and vapor lines from the outdoor unit to the indoor unit coil (braze connections). Use Lennox L15 (sweat, non-flare) series line set, or field-fabricated refrigerant line sizes as listed in table 2.

Table 2. Refrigerant Line Set — Inches (mm)

Model	Valve Field Connections		Recommended Line Set		
	Liquid Line	Vapor Line	Liquid Line	Vapor Line	L15 Line Sets
-018 -024 -030	3/8 in. (10 mm)	3/4 in. (19 mm)	3/8 in. (10 mm)	3/4 in. (19 mm)	L15-41 15 ft. - 50 ft. (4.6 m - 15 m)
-036 -042 -048	3/8 in. (10 mm)	7/8 in. (22 mm)	3/8 in. (10 mm)	7/8 in. (22 mm)	L15-65 15 ft. - 50 ft. (4.6 m - 15 m)
-060	3/8 in. (10 mm)	1-1/8 in. (29 mm)	3/8 in. (10 mm)	1-1/8 in. (29 mm)	Field Fabricated

NOTE — When installing refrigerant lines longer than 50 feet, see the *Lennox Refrigerant Piping Design and Fabrication Guidelines, CORP. 9351-L9*, or contact *Lennox Technical Support Product Applications* for assistance.

To obtain the correct information from Lennox, be sure to communicate the following information:

- Model (XP14) and size of unit (e.g. -036).
- Line set diameters for the unit being installed as listed in table 2 and total length of installation.
- Number of elbows vertical rise or drop in the piping.

The compressor is charged with sufficient Polyol ester oil for line set lengths up to 50 feet. Recommend adding oil to system based on the amount of refrigerant charge in the system. No need to add oil in system with 20 pounds of refrigerant or less. For systems over 20 pounds - add one ounce of every five pounds of refrigerant.

Recommended topping-off POE oils are Mobil EAL ARCTIC 22 CC or ICI EMKARATE™ RL32CF.

WARNING

Polyol Ester (POE) oils used with HFC-410A refrigerant absorb moisture very quickly. It is very important that the refrigerant system be kept closed as much as possible. DO NOT remove line set caps or service valve stub caps until you are ready to make connections.

IMPORTANT

Mineral oils are not compatible with HFC-410A. If oil must be added, it must be a Polyol Ester oil.

Line Set Isolation — The following illustrations are examples of proper refrigerant line set isolation:

REFRIGERANT LINE SET — TRANSITION FROM VERTICAL TO HORIZONTAL

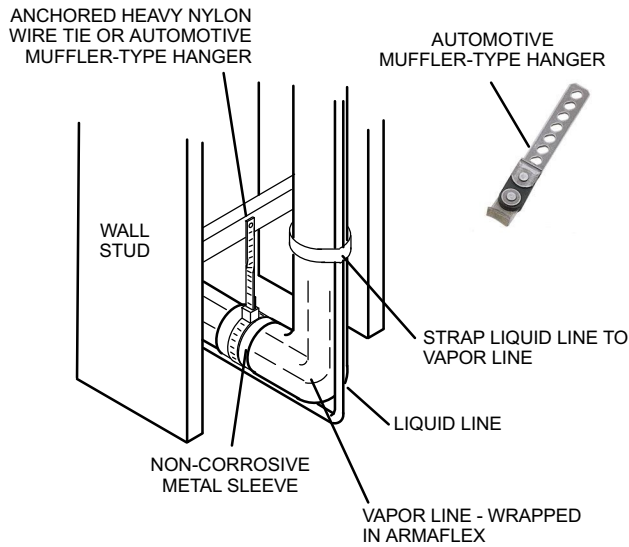

REFRIGERANT LINE SET — INSTALLING VERTICAL RUNS (NEW CONSTRUCTION SHOWN)

NOTE — Insulate liquid line when it is routed through areas where the surrounding ambient temperature could become higher than the temperature of the liquid line or when pressure drop is equal to or greater than 20 psig.

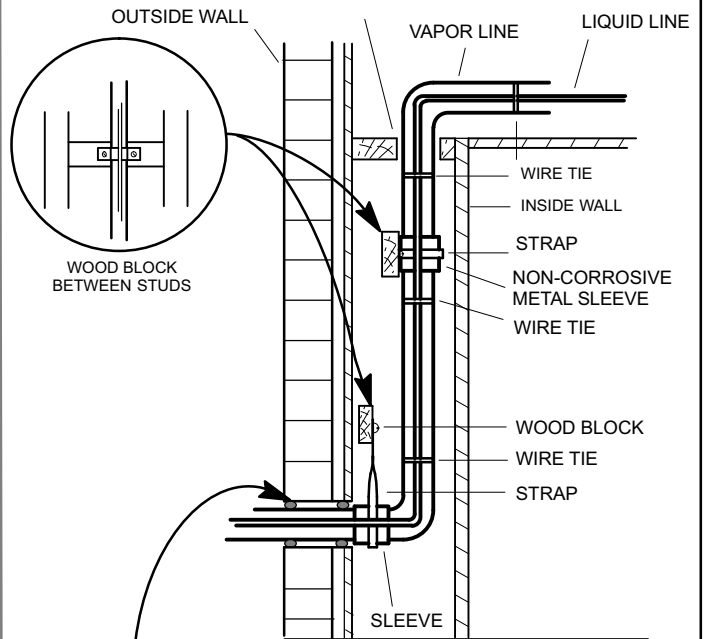

REFRIGERANT LINE SET — INSTALLING HORIZONTAL RUNS

To hang line set from joist or rafter, use either metal strapping material or anchored heavy nylon wire ties.

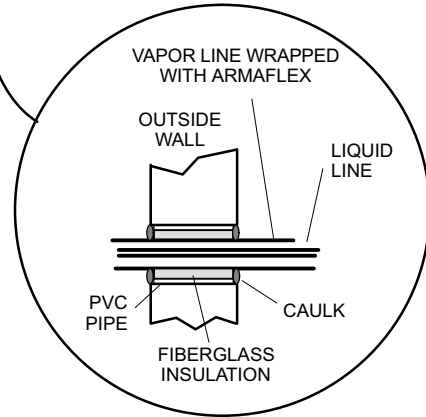
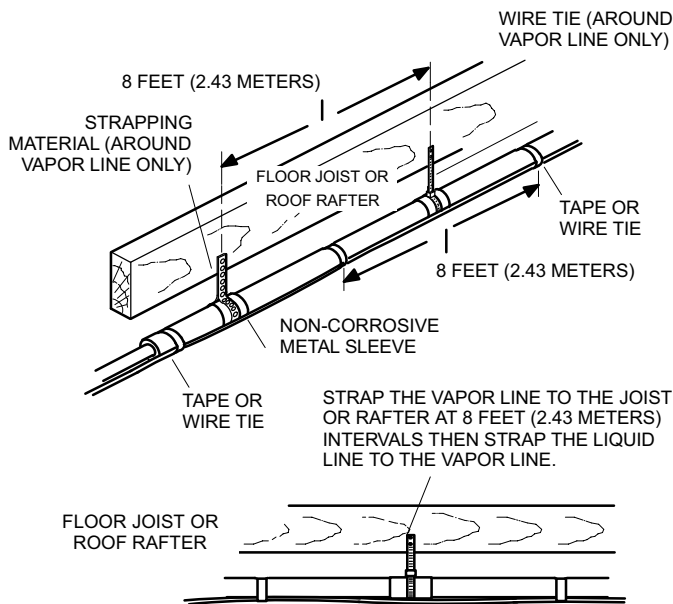

NOTE — Similar installation practices should be used if line set is to be installed on exterior of outside wall.

Figure 7. Line Set Installation

Brazing Connections

Use the procedures outline in figures 8 and 9 for brazing line set connections to service valves.

WARNING



Danger of fire. Bleeding the refrigerant charge from only the high side may result in pressurization of the low side shell and suction tubing. Application of a brazing torch to a pressurized system may result in ignition of the refrigerant and oil mixture - Check the high and low pressures before applying heat.

WARNING



When using a high pressure gas such as dry nitrogen to pressurize a refrigeration or air conditioning system, use a regulator that can control the pressure down to 1 or 2 psig (6.9 to 13.8 kPa).

CAUTION

Brazing alloys and flux contain materials which are hazardous to your health.

Avoid breathing vapors or fumes from brazing operations. Perform operations only in well-ventilated areas.

Wear gloves and protective goggles or face shield to protect against burns.

Wash hands with soap and water after handling brazing alloys and flux.

IMPORTANT

Connect gauge set low pressure side to vapor line service valve and repeat procedure starting at paragraph 4 for brazing the liquid line to service port valve.

IMPORTANT

Allow braze joint to cool before removing the wet rag from the service valve. Temperatures above 250°F can damage valve seals.

IMPORTANT

Use silver alloy brazing rods with 5% minimum silver alloy for copper-to-copper brazing. Use 45% minimum alloy for copper-to-brass and copper-to-steel brazing.

WARNING



Fire, Explosion and Personal Safety Hazard.

Failure to follow this warning could result in damage, personal injury or death.

Never use oxygen to pressurize or purge refrigeration lines. Oxygen, when exposed to a spark or open flame, can cause fire and/or an explosion, that could result in property damage, personal injury or death.

1 CUT AND DEBUR

Cut ends of the refrigerant lines square (free from nicks or dents) and debur the ends. The pipe must remain round. Do not crimp end of the line.

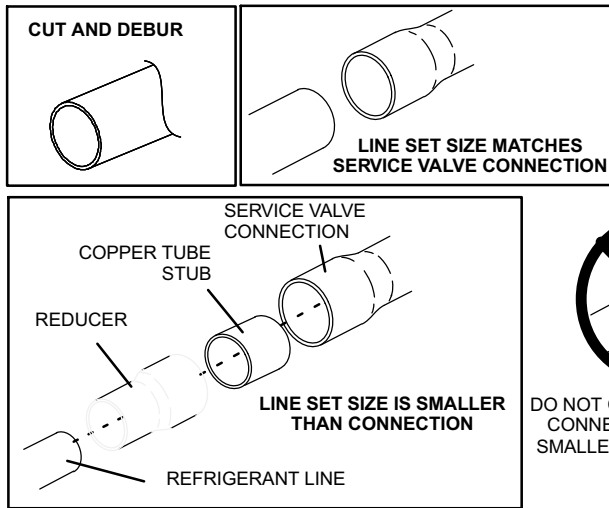

2 CAP AND CORE REMOVAL

Remove service cap and core from both the suction / vapor and liquid line service ports.

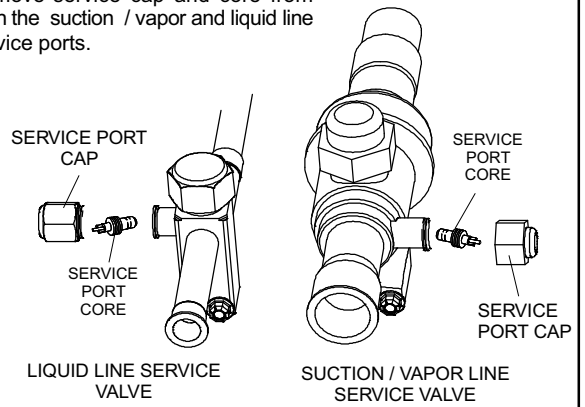

DO NOT CRIMP SERVICE VALVE CONNECTOR WHEN PIPE IS SMALLER THAN CONNECTION

3 ATTACH THE MANIFOLD GAUGE SET FOR BRAZING LIQUID AND SUCTION / VAPOR LINE SERVICE VALVES

Flow regulated nitrogen (at 1 to 2 psig) through the low-side refrigeration gauge set into the liquid line service port valve, and out of the suction / vapor line service port valve.

- A Connect gauge set low pressure side to liquid line service valve (service port).
- B Connect gauge set center port to bottle of nitrogen with regulator.
- C Remove core from valve in suction / vapor line service port to allow nitrogen to escape.

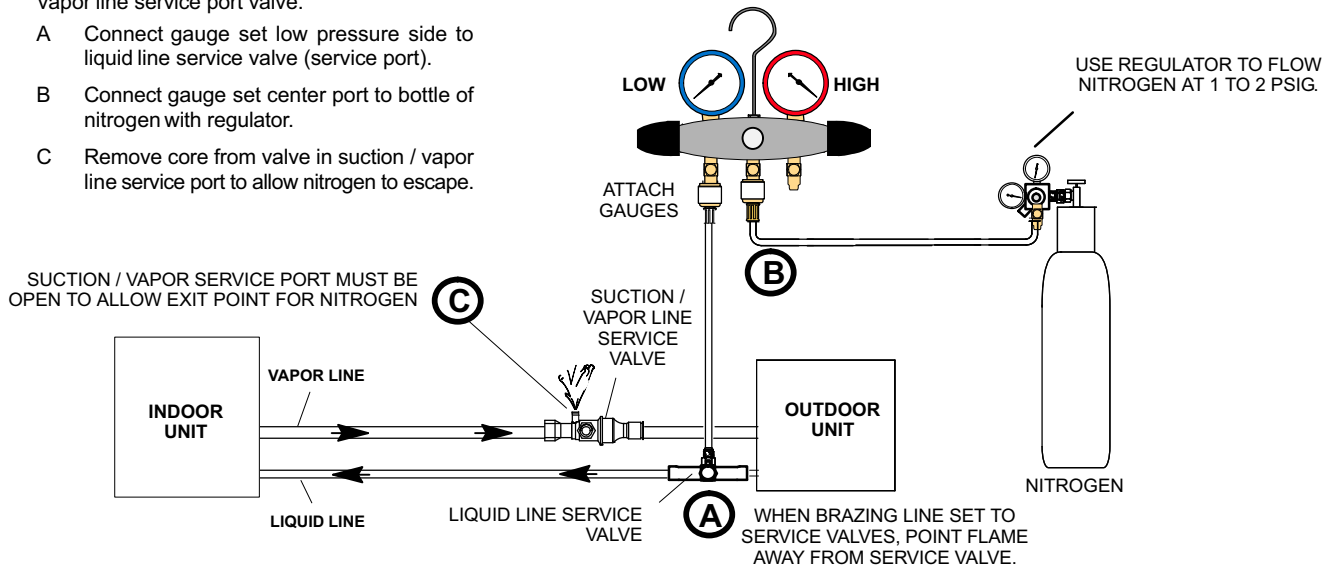

Figure 8. Brazing Procedures

4 WRAP SERVICE VALVES

To help protect service valve seals during brazing, wrap water saturated cloths around service valve bodies and copper tube stubs. Use additional water saturated cloths underneath the valve body to protect the base paint.

5 FLOW NITROGEN

Flow regulated nitrogen (at 1 to 2 psig) through the refrigeration gauge set into the valve stem port connection on the liquid service valve and out of the suction / vapor valve stem port. See steps **3A**, **3B** and **3C** on manifold gauge set connections

6 BRAZE LINE SET

Wrap both service valves with water saturated cloths as illustrated here and as mentioned in step 4, before brazing to line set. Water saturated cloths must remain water saturated throughout the brazing and cool-down process.

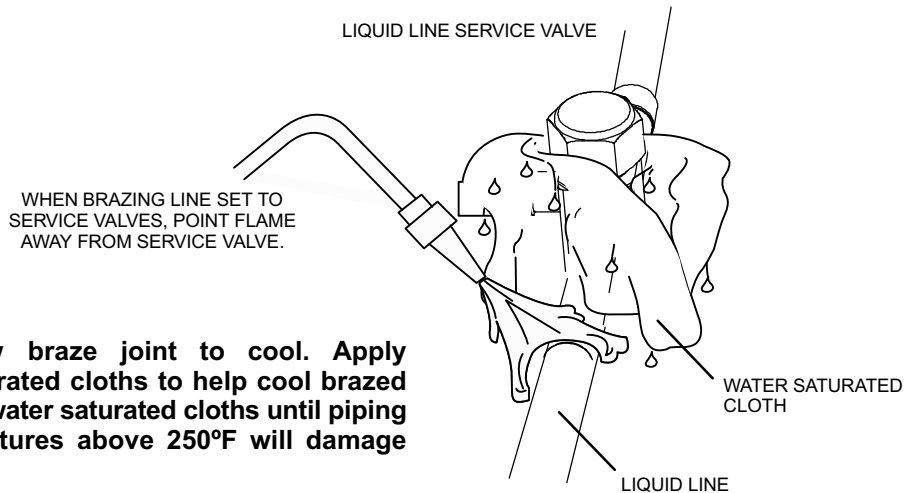

IMPORTANT — Allow braze joint to cool. Apply additional water saturated cloths to help cool brazed joint. Do not remove water saturated cloths until piping has cooled. Temperatures above 250°F will damage valve seals.

WARNING

- 1. FIRE, PERSONAL INJURY, OR PROPERTY DAMAGE** will result if you do not wrap a water saturated cloth around both liquid and suction line service valve bodies and copper tube stub while brazing in the line set! The braze, when complete, must be quenched with water to absorb any residual heat.
- 2. Do not open service valves until refrigerant lines and indoor coil have been leak-tested and evacuated. Refer to procedures provided in this supplement.**

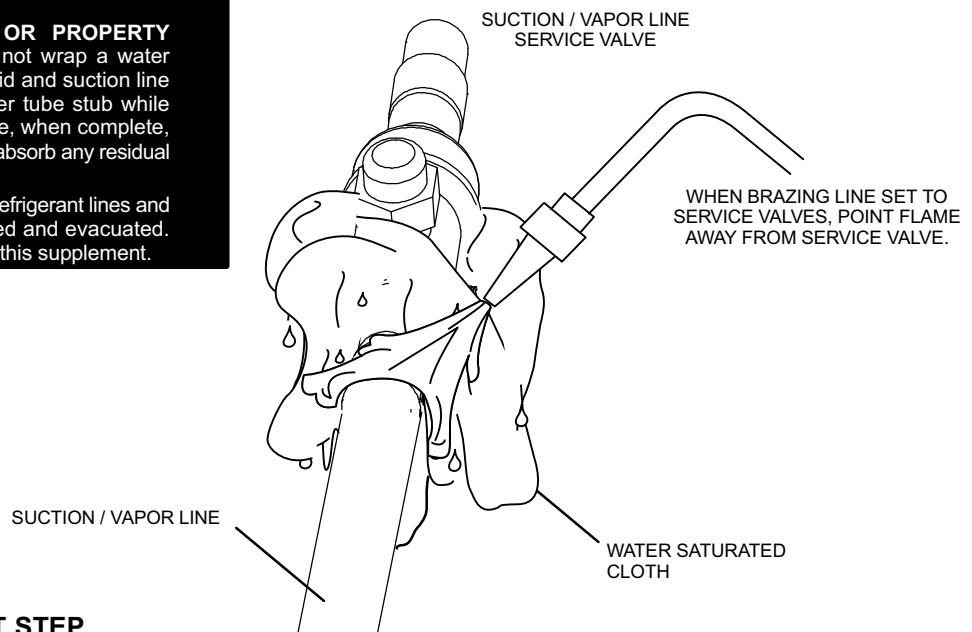

7 PREPARATION FOR NEXT STEP

After all connections have been brazed, disconnect manifold gauge set from service ports. Apply additional water saturated cloths to both services valves to cool piping. Once piping is cool, remove all water saturated cloths. Refer to the unit installation instructions for the next step in preparing the unit.

Figure 9. Brazing Procedures (continued)

Flushing Line Set and Indoor Coil

1A TYPICAL EXISTING FIXED ORIFICE REMOVAL PROCEDURE (UNCASED OR COIL SHOWN)

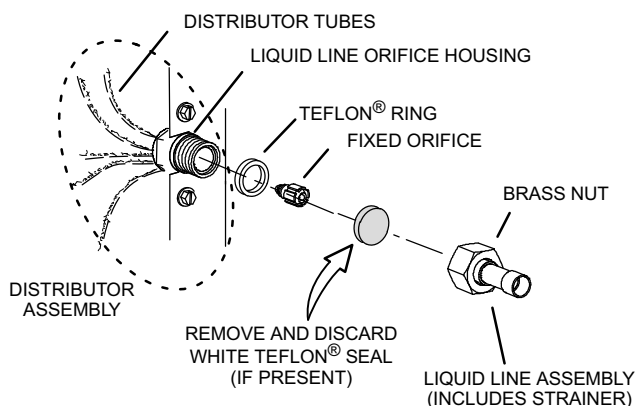

- On fully cased coils, remove the coil access and plumbing panels.
- Remove any shipping clamps holding the liquid line and distributor assembly.
- Using two wrenches, disconnect liquid line from liquid line orifice housing. Take care not to twist or damage distributor tubes during this process.
- Remove and discard fixed orifice, valve stem assembly if present and Teflon® washer as illustrated above.
- Use a field-provided fitting to temporary reconnect the liquid line to the indoor unit's liquid line orifice housing.

1B TYPICAL EXISTING EXPANSION VALVE REMOVAL PROCEDURE (UNCASED COIL SHOWN)

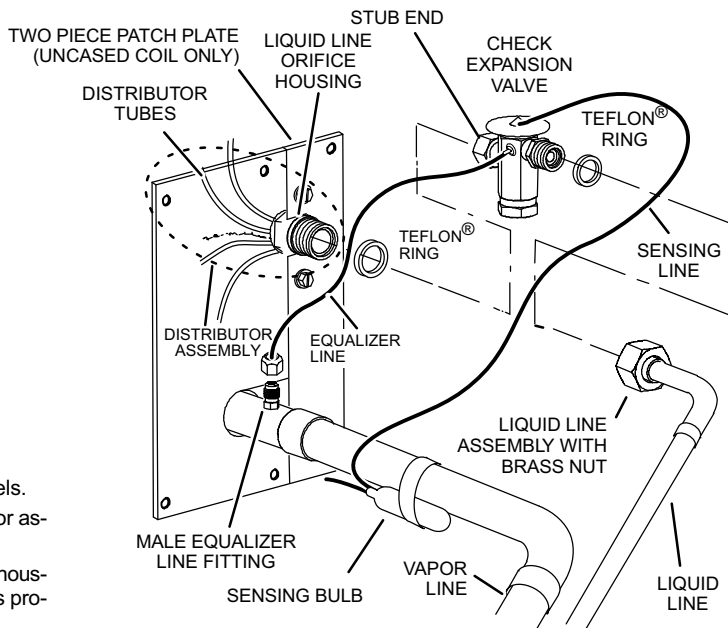

- On fully cased coils, remove the coil access and plumbing panels.
- Remove any shipping clamps holding the liquid line and distributor assembly.
- Disconnect the equalizer line from the check expansion valve equalizer line fitting on the vapor line.
- Remove the vapor line sensing bulb.
- Disconnect the liquid line from the check expansion valve at the liquid line assembly.
- Disconnect the check expansion valve from the liquid line orifice housing. Take care not to twist or damage distributor tubes during this process.
- Remove and discard check expansion valve and the two Teflon® rings.
- Use a field-provided fitting to temporary reconnect the liquid line to the indoor unit's liquid line orifice housing.

2 CONNECT GAUGES AND EQUIPMENT FOR FLUSHING PROCEDURE

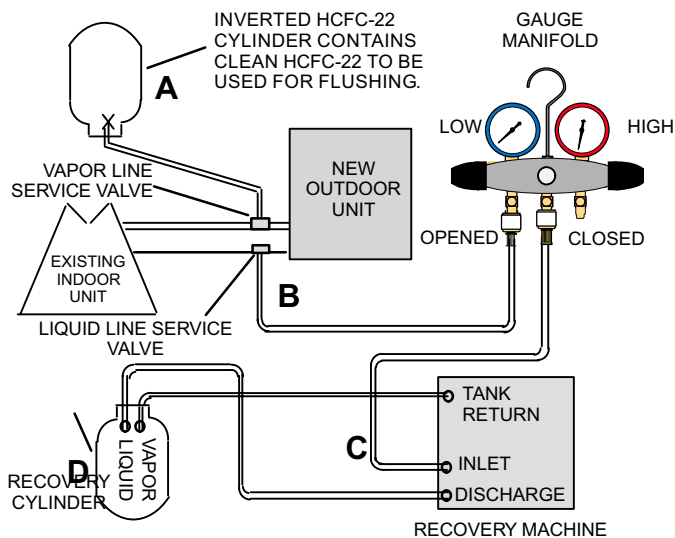

- Inverted HCFC-22 cylinder with clean refrigerant to the vapor service valve.
- HCFC-22 gauge set (low side) to the liquid line valve.
- HCFC-22 gauge set center port to inlet on the recovery machine with an empty recovery tank to the gauge set.
- Connect recovery tank to recovery machines per machine instructions.

3 FLUSHING LINE SET

The line set and indoor unit coil must be flushed with at least the same amount of clean refrigerant that previously charged the system. Check the charge in the flushing cylinder before proceeding.

- Set the recovery machine for liquid recovery and start the recovery machine. Open the gauge set valves to allow the recovery machine to pull a vacuum on the existing system line set and indoor unit coil.
- Invert the cylinder of clean HCFC-22 and open its valve to allow liquid refrigerant to flow into the system through the vapor line valve. Allow the refrigerant to pass from the cylinder and through the line set and the indoor unit coil before it enters the recovery machine.
- After all of the liquid refrigerant has been recovered, switch the recovery machine to vapor recovery so that all of the HCFC-22 vapor is recovered. Allow the recovery machine to pull down to 0 on the system.
- Close the valve on the inverted HCFC-22 drum and the gauge set valves. Pump the remaining refrigerant out of the recovery machine and turn the machine off.

Figure 10. Installing Indoor Expansion Valve

Installing Indoor Metering Device

This outdoor unit is designed for use in systems that use check expansion valve metering devices at the indoor coil. See the *Lennox XP14 Engineering Handbook* for approved expansion valve kit match-ups. The expansion valve unit can be installed internal or external to the indoor

coil. In applications where an uncased coil is being installed in a field-provided plenum, install the expansion valve in a manner that will provide access for field servicing of the expansion valve. Refer to below illustration for reference during installation of expansion valve unit.

INDOOR EXPANSION VALVE INSTALLATION

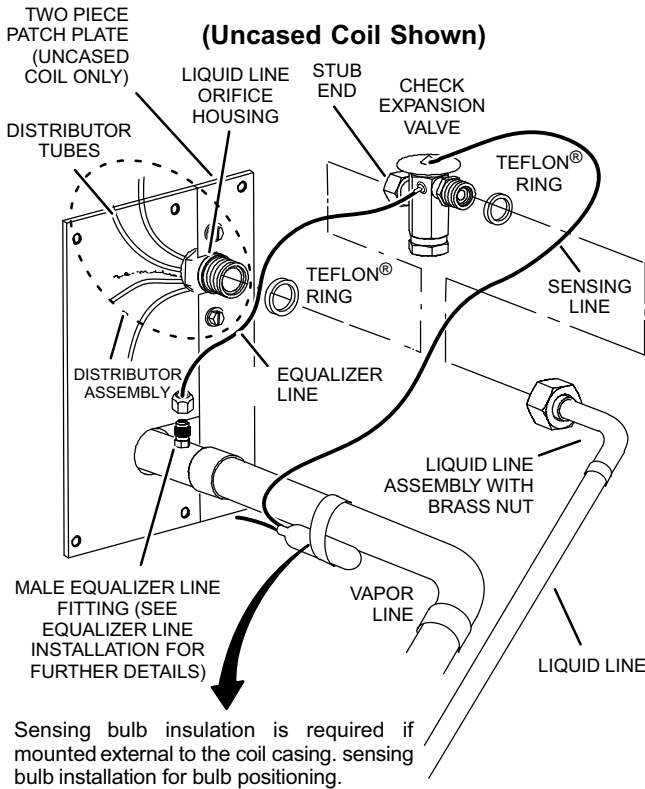

- Remove the field-provided fitting that temporary reconnected the liquid line to the indoor unit's distributor assembly.
- Install one of the provided Teflon® rings around the stubbed end of the expansion valve and lightly lubricate the connector threads and expose surface of the Teflon® ring with refrigerant oil.
- Attach the stubbed end of the expansion valve to the liquid line orifice housing. Finger tighten and use an appropriately sized wrench to turn an additional 1/2 turn clockwise as illustrated in the figure above, or 20 ft-lb.
- Place the remaining Teflon® washer around the other end of the expansion valve. Lightly lubricate connector threads and expose surface of the Teflon® ring with refrigerant oil.
- Attach the liquid line assembly to the expansion valve. Finger tighten and use an appropriately sized wrench to turn an additional 1/2 turn clockwise as illustrated in the figure above or 20 ft-lb.

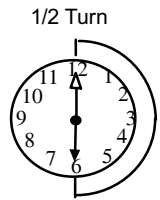

SENSING BULB INSTALLATION

- Attach the vapor line sensing bulb in the proper orientation as illustrated to the right using the clamp and screws provided.

NOTE — Confirm proper thermal contact between vapor line and expansion bulb before insulating the sensing bulb once installed.

- Connect the equalizer line from the expansion valve to the equalizer vapor port on the vapor line. Finger tighten the flare nut plus 1/8 turn (7 ft-lbs) as illustrated below.

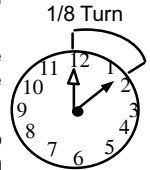

EQUALIZER LINE INSTALLATION

- Remove and discard either the flare seal cap or flare nut with copper flare seal bonnet from the equalizer line port on the vapor line as illustrated in the figure to the right.
- Remove and discard either the flare seal cap or flare nut with copper flare seal bonnet from the equalizer line port on the vapor line as illustrated in the figure to the right.

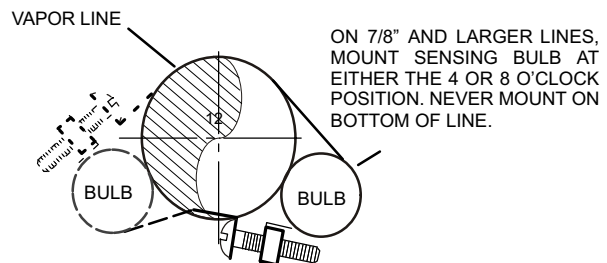
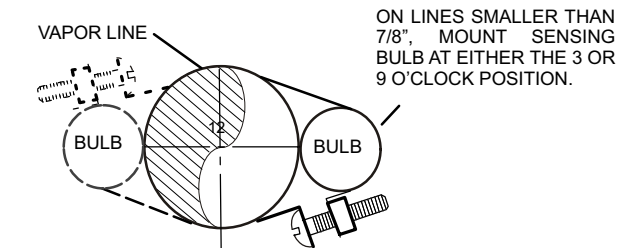
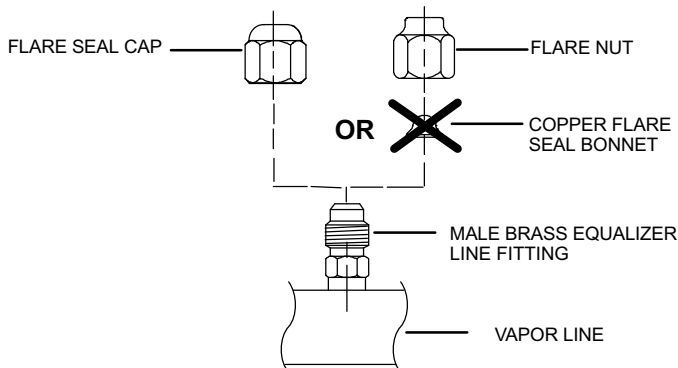

NOTE — NEVER MOUNT ON BOTTOM OF LINE.

Figure 11. Installing Indoor Expansion Valve

⚠ IMPORTANT

The Environmental Protection Agency (EPA) prohibits the intentional venting of HFC refrigerants during maintenance, service, repair and disposal of appliance. Approved methods of recovery, recycling or reclaiming must be followed.

⚠ IMPORTANT

If this unit is being matched with an approved line set or indoor unit coil which was previously charged with mineral oil, or if it is being matched with a coil which was manufactured before January of 1999, the coil and line set must be flushed prior to installation. Take care to empty all existing traps. Polyol ester (POE) oils are used in Lennox units charged with HFC-410A refrigerant. Residual mineral oil can act as an insulator, preventing proper heat transfer. It can also clog the expansion device, and reduce the system performance and capacity. Failure to properly flush the system per the instructions below will void the warranty.

Leak Test Line Set and Indoor Coil

⚠ WARNING



When using a high pressure gas such as dry nitrogen to pressurize a refrigeration or air conditioning system, use a regulator that can control the pressure down to 1 or 2 psig (6.9 to 13.8 kPa).

⚠ IMPORTANT

Leak detector must be capable of sensing HFC refrigerant.

⚠ WARNING

Refrigerant can be harmful if it is inhaled. Refrigerant must be used and recovered responsibly.

Failure to follow this warning may result in personal injury or death.

1 CONNECT GAUGE SET

- A Connect an HFC-410A manifold gauge set high pressure hose to the vapor valve service port.

NOTE — Normally, the high pressure hose is connected to the liquid line port. However, connecting it to the vapor port better protects the manifold gauge set from high pressure damage.

- B With both manifold valves closed, connect the cylinder of HFC-410A refrigerant to the center port of the manifold gauge set.

NOTE — Later in the procedure, the HFC-410A container will be replaced by the nitrogen container.

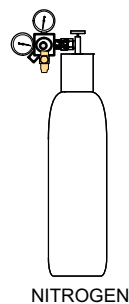

NITROGEN

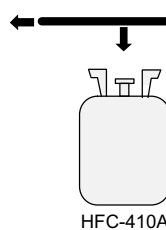

HFC-410A

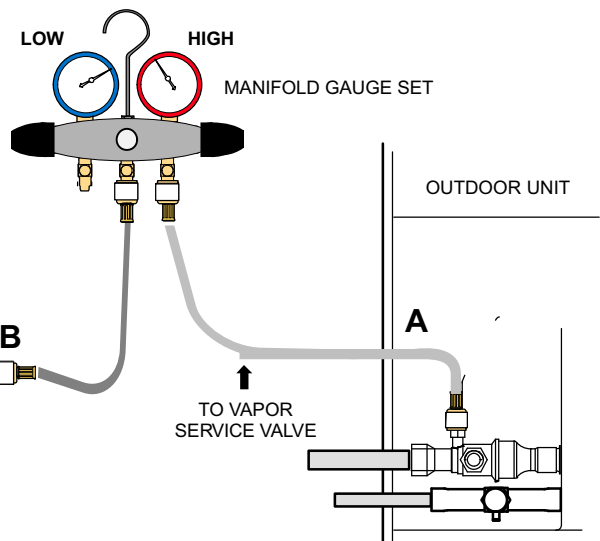

2 TEST FOR LEAKS

After the line set has been connected to the indoor and outdoor units, check the line set connections and indoor unit for leaks. Use the following procedure to test for leaks:

- A With both manifold valves closed, connect the cylinder of HFC-410A refrigerant to the center port of the manifold gauge set. Open the valve on the HFC-410A cylinder (vapor only).
- B Open the high pressure side of the manifold to allow HFC-410A into the line set and indoor unit. Weigh in a trace amount of HFC-410A. [A trace amount is a maximum of two ounces (57 g) refrigerant or three pounds (31 kPa) pressure]. Close the valve on the HFC-410A cylinder and the valve on the high pressure side of the manifold gauge set. Disconnect the HFC-410A cylinder.
- C Connect a cylinder of dry nitrogen with a pressure regulating valve to the center port of the manifold gauge set.
- D Adjust dry nitrogen pressure to 150 psig (1034 kPa). Open the valve on the high side of the manifold gauge set in order to pressurize the line set and the indoor unit.
- E After a few minutes, open one of the service valve ports and verify that the refrigerant added to the system earlier is measurable with a leak detector.
- F After leak testing disconnect gauges from service ports.

Figure 12. Leak Test

Evacuating Line Set and Indoor Coil

1 CONNECT GAUGE SET

NOTE — Remove cores from service valves (if not already done).

- A Connect low side of manifold gauge set with 1/4 SAE in-line tee to vapor line service valve
- B Connect high side of manifold gauge set to liquid line service valve
- C Connect micron gauge available connector on the 1/4 SAE in-line tee.
- D Connect the vacuum pump (with nitrogen gauge) to the center port of the manifold gauge set. The center port line will be used later for both the HFC-410A and nitrogen containers.

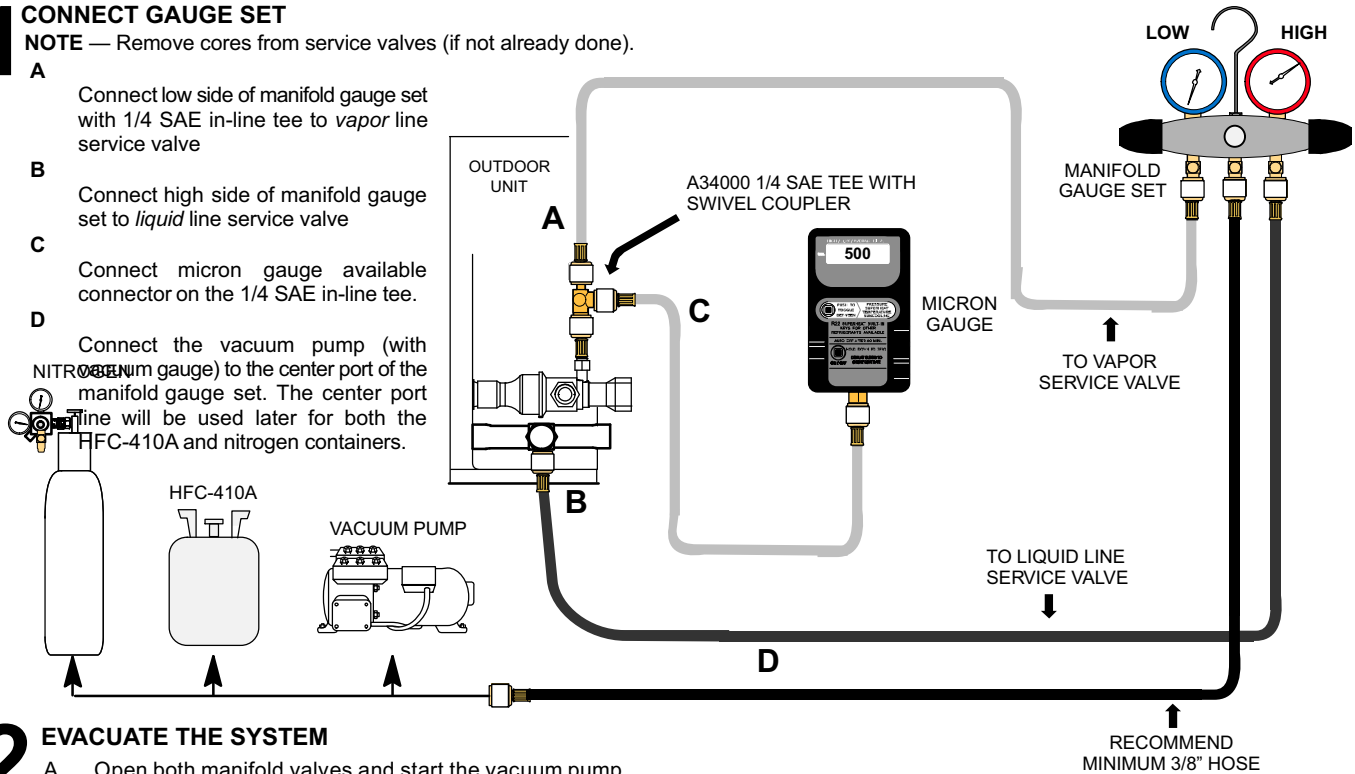

2 EVACUATE THE SYSTEM

- A Open both manifold valves and start the vacuum pump.
- B Evacuate the line set and indoor unit to an **absolute pressure** of 23,000 microns (29.01 inches of mercury).
 - NOTE** — During the early stages of evacuation, it is desirable to close the manifold gauge valve at least once. A rapid rise in pressure indicates a relatively large leak. If this occurs, **repeat the leak testing procedure**.
 - NOTE** — The term **absolute pressure** means the total actual pressure within a given volume or system, above the absolute zero of pressure. Absolute pressure in a vacuum is equal to atmospheric pressure minus vacuum pressure.
- C When the absolute pressure reaches 23,000 microns (29.01 inches of mercury), perform the following:
 - Close manifold gauge valves
 - Close valve on vacuum pump
 - Turn off vacuum pump
 - Disconnect manifold gauge center port hose from vacuum pump
 - Attach manifold center port hose to a dry nitrogen cylinder with pressure regulator set to 150 psig (1034 kPa) and purge the hose.
 - Open manifold gauge valves to break the vacuum in the line set and indoor unit.
 - Close manifold gauge valves.
- D Shut off the dry nitrogen cylinder and remove the manifold gauge hose from the cylinder. Open the manifold gauge valves to release the dry nitrogen from the line set and indoor unit.
- E Reconnect the manifold gauge to the vacuum pump, turn the pump on, and continue to evacuate the line set and indoor unit until the absolute pressure does not rise above 500 microns (29.9 inches of mercury) within a 20-minute period after shutting off the vacuum pump and closing the manifold gauge valves.
- F When the absolute pressure requirement above has been met, disconnect the manifold hose from the vacuum pump and connect it to an upright cylinder of HFC-410A refrigerant. Open the manifold gauge valve 1 to 2 psig in order to release the vacuum in the line set and indoor unit.
- G Perform the following:
 - Close manifold gauge valves.
 - Shut off HFC-410A cylinder.
 - Reinstall service valve cores by removing manifold hose from service valve. Quickly install cores with core tool while maintaining a positive system pressure.
 - Replace stem caps and secure finger tight, then tighten an additional one-sixth (1/6) of a turn as illustrated.

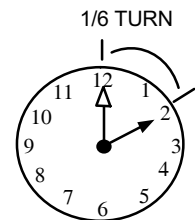

Figure 13. Evacuating System

⚠ IMPORTANT

Use a thermocouple or thermistor electronic vacuum gauge that is calibrated in microns. Use an instrument capable of accurately measuring down to 50 microns.

⚠ WARNING

Danger of Equipment Damage. Avoid deep vacuum operation. Do not use compressors to evacuate a system. Extremely low vacuums can cause internal arcing and compressor failure. Damage caused by deep vacuum operation will void warranty.

Evacuating the system of non-condensables is critical for proper operation of the unit. Non-condensables are defined as any gas that will not condense under

temperatures and pressures present during operation of an air conditioning system. Non-condensables and water suction combine with refrigerant to produce substances that corrode copper piping and compressor parts.

Electrical

In the U.S.A., wiring must conform with current local codes and the current National Electric Code (NEC). In Canada, wiring must conform with current local codes and the current Canadian Electrical Code (CEC).

Refer to the furnace or air handler installation instructions for additional wiring application diagrams and refer to unit nameplate for minimum circuit ampacity and maximum overcurrent protection size.

24VAC TRANSFORMER

Use the transformer provided with the furnace or air handler for low-voltage control power (24VAC - 40 VA minimum)

1 SIZE CIRCUIT AND INSTALL DISCONNECT SWITCH

Refer to the unit nameplate for minimum circuit ampacity, and maximum fuse or circuit breaker (HACR per NEC). Install power wiring and properly sized disconnect switch.

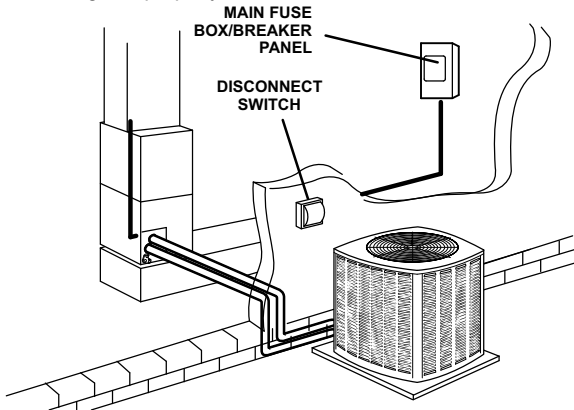

NOTE — Units are approved for use only with copper conductors. Ground unit at disconnect switch or to an earth ground.

2 INSTALL THERMOSTAT

Install room thermostat (ordered separately) on an inside wall approximately in the center of the conditioned area and 5 feet (1.5m) from the floor. It should not be installed on an outside wall or where it can be affected by sunlight or drafts.

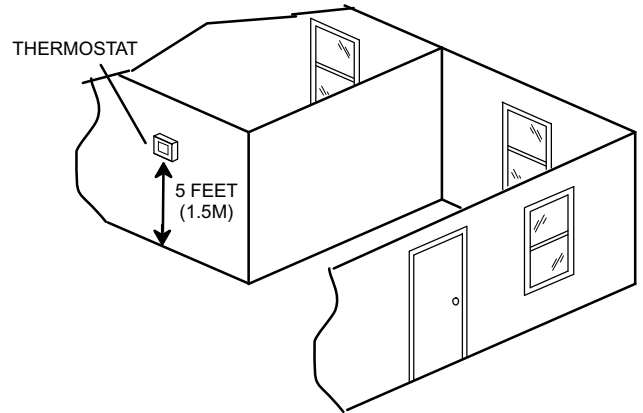

NOTE — 24VAC, Class II circuit connections are made in the control panel.

3 UNIT LOW VOLTAGE CONNECTIONS

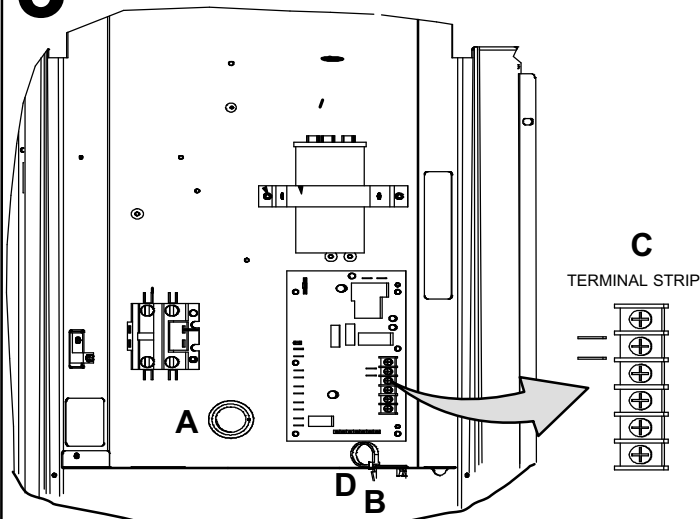

- HIGH VOLTAGE FIELD WIRING
- FACTORY WIRING
- LOW VOLTAGE (24V) FIELD WIRING

WIRE RUN LENGTH	AWG#	INSULATION TYPE
LESS THAN 100' (30 METERS)	18	TEMPERATURE RATING
MORE THAN 100' (30 METERS)	16	35°C MINIMUM.

- A** Run 24VAC control wires through cutout with grommet.
- B** Run 24VAC control wires through wire tie.
- C** Make 24VAC control wire connections defrost control terminal strip.
- D** Tighten wire tie to security 24V control wiring.

NOTE - FOR PROPER VOLTAGES, SELECT THERMOSTAT WIRE (CONTROL WIRES) GAUGE PER TABLE ABOVE.

NOTE - WIRE TIE PROVIDES LOW VOLTAGE WIRE STRAIN RELIEF AND TO MAINTAIN SEPARATION OF FIELD INSTALLED LOW AND HIGH VOLTAGE CIRCUITS.

NOTE - DO NOT BUNDLE ANY EXCESS 24VAC CONTROL WIRES INSIDE CONTROL BOX.

Servicing Units Void of Charge

If the outdoor unit is void of refrigerant, clean the system using the procedure described below.

1. Leak check system using procedure outlined on page 21.
2. Evacuate the system using procedure outlined on page 22.
3. Use nitrogen to break the vacuum and install a new filter drier in the system.
4. Evacuate the system again using procedure outlined on page 22.
5. Weigh in refrigerant using procedure outlined in figure 16.
6. Monitor the system to determine the amount of moisture remaining in the oil. It may be necessary to replace the filter drier several times to achieve the required dryness level. **If system dryness is not verified, the compressor will fail in the future.**

Unit Start-Up

⚠ IMPORTANT

If unit is equipped with a crankcase heater, it should be energized 24 hours before unit start-up to prevent compressor damage as a result of slugging.

1. Rotate fan to check for binding.

2. Inspect all factory- and field-installed wiring for loose connections.
3. After evacuation is complete, open both the liquid and vapor line service valves to release the refrigerant charge contained in outdoor unit into the system.
4. Replace the stem caps and tighten to the value listed in table 1.
5. Check voltage supply at the disconnect switch. The voltage must be within the range listed on the unit's nameplate. If not, do not start the equipment until you have consulted with the power company and the voltage condition has been corrected.
6. Set the thermostat for a cooling demand. Turn on power to the indoor indoor unit and close the outdoor unit disconnect switch to start the unit.
7. Recheck voltage while the unit is running. Power must be within range shown on the nameplate.
8. Check system for sufficient refrigerant by using the procedures listed under *System Charge*.

System Refrigerant

This section outlines procedures for:

1. Connecting gauge set for testing and charging;
2. Checking and adjusting indoor airflow;
3. Adding or removing refrigerant.

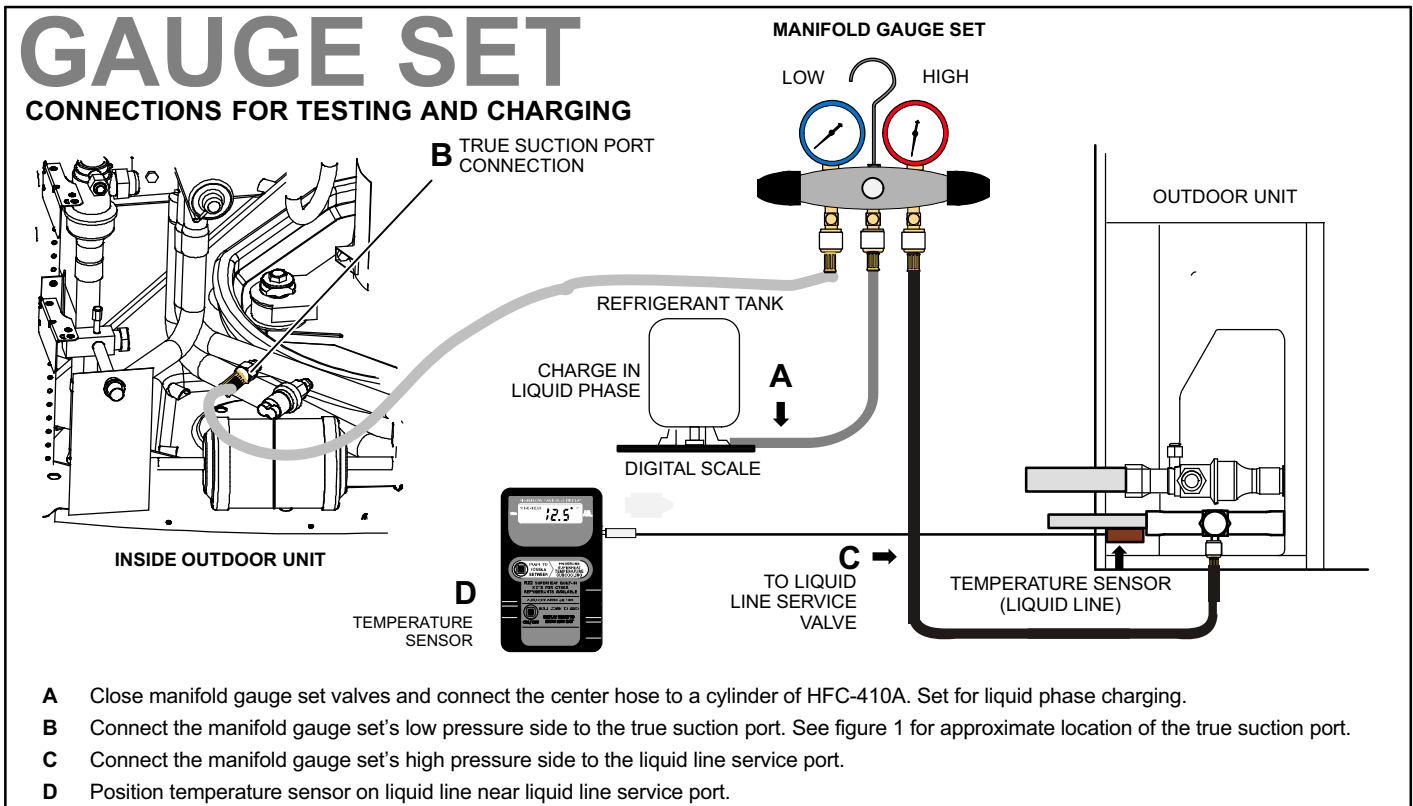

Figure 14. Gauge Set Setup and Connections

ADDING OR REMOVING REFRIGERANT

This system uses HFC-410A refrigerant which operates at much higher pressures than HCFC-22. The pre-installed liquid line filter drier is approved for use with HFC-410A only. Do not replace it with components designed for use with HCFC-22. This unit is NOT approved for use with coils which use capillary tubes or fixed orifices as a refrigerant metering device. Check airflow using the Delta-T (DT) process using the illustration in figure 15.

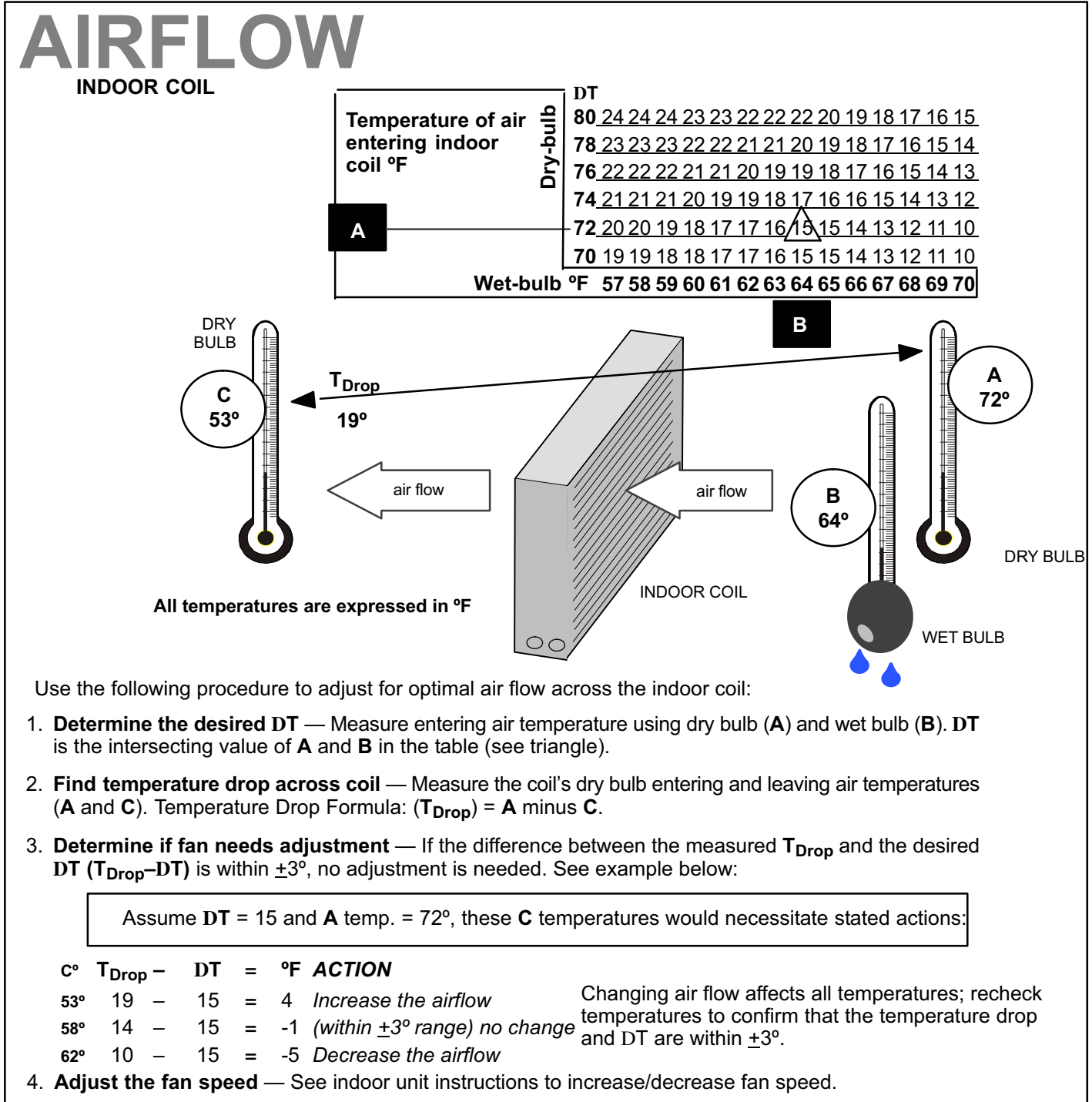

Figure 15. Checking Indoor Airflow over Evaporator Coil using Delta-T Chart

Table 3. Unit Indoor Matchups for Subcooling (All Models)

INDOOR MATCHUPS	Target Subcooling		*Add charge	INDOOR MATCHUPS	Target Subcooling		*Add charge	INDOOR MATCHUPS	Target Subcooling		*Add charge
	Heating (±5°F)	Cooling (±1°F)			Heating (±5°F)	Cooling (±1°F)			Heating (±5°F)	Cooling (±1°F)	
XP14-018			lb oz	XP14-030 (Continued)			lb oz	XP14-042 (Continued)			lb oz
CBX27UH-018/024	13	7	0 8	CH33-42B	6	6	1 12	CR33-50/60C,-60D	26	6	0 4
CBX32MV-018/024	15	7	0 0	CR33-30/36A/B/C	30	8	0 8	CX34-62C, -62D	12	6	0 9
CBX40UHV-024	15	7	0 0	CX34-31A/B	11	6	1 6	CX34-49C	12	6	0 7
XP14-024			lb oz	CX34-38A/B S/N# 6007 and after	6	6	2 3	CX34-60D	12	6	0 4
CBX26UH-024	25	7	0 0	CX34-38A/B Before S/N# 6007	11	6	2 3	XP14-048			lb oz
CBX27UH-018/024	15	8	1 2	CX34-43B/C	15	11	2 14	CBX26UH-048	8	7	1 9
CBX32M-018/024	16	8	0 14	XP14-036			lb oz	CBX27UH-048	11	8	1 2
CBX32M-030	15	8	1 3	C33-44C	13	6	0 0	CBX32M-048, -060	11	8	1 2
CBX32MV-018/024	16	8	0 14	CBX26UH-036	26	5	0 0	CBX32MV-048	25	8	0 0
CBX32MV-024/030	15	8	1 2	CBX26UH-037	25	4	1 9	CBX32MV-060	11	8	1 2
CBX40UHV-024	16	8	0 14	CBX27UH-036	13	6	0 3	CBX40UHV-048	25	8	0 0
CBX40UHV-030	15	8	1 2	CBX32M-036	13	6	0 2	CBX40UHV-060	11	8	1 2
CH23-41	16	8	0 2	CBX32M-042	13	6	0 3	CBX32MV-068	10	7	1 12
CH33-25A	16	6	0 7	CBX32MV-036	13	6	0 3	CH23-68	20	9	2 9
CH33-42B	14	11	1 10	CBX32MV-048	11	8	2 5	CH33-50/60C	11	8	1 1
CH33-36A	16	8	1 0	CBX40UHV-036	13	6	0 3	CH33-62D	10	7	1 14
CH33-36C	16	8	0 4	CBX40UHV-042, -048	11	8	2 5	CH33-60D	11	8	0 0
CR33-30/36A/B/C	25	7	0 2	CH33-50/60C	11	8	2 5	CR33-50/60C	35	5	0 0
CX34-25A/B	16	8	0 14	CH33-44B	13	6	1 7	CR33-60D	37	6	0 0
CX34-31A/B	15	8	1 3	CH33-48B	13	6	1 8	CX34-62C, -62D	10	7	1 7
CX34-36A/B/C	16	8	1 8	CR33-50/60C	25	4	1 15	CX34-49D	11	8	0 14
CX34-38A/B S/N# 6007 and after	11	11	2 2	CR33-48B/C	25	5	0 9	CX34-60D	11	8	0 0
CX34-38A/B before S/N# 6007	14	11	2 2	CX34-49C	13	6	2 4	XP14-060			lb oz
XP14-030			lb oz	CX34-43B/C, -50/60C	13	6	1 8	CBX26UH-048	12	7	1 0
CH23-41	11	6	0 8	CX34-38A/B S/N# 6007 and after	6	6	0 0	CBX26UH-060	14	4	0 0
CH23-51	6	6	1 12	CX34-38A/B before S/N# 6007	13	6	0 0	CBX27UH-060	12	5	0 0
CBX26UH-024	30	8	0 6	XP14-042			lb oz	CBX32M-048, -060	12	5	0 0
CBX26UH-030	29	8	2 3	CH23-68	20	9	0 13	CBX32MV-048, -060	12	5	0 0
CBX27UH-030	11	6	2 4	CBX26UH-042	27	6	0 0	CBX40UHV-048, -060	12	5	0 0
CBX32M-030	11	6	1 6	CBX27UH-042	12	6	0 8	CBX32MV-068	12	7	1 0
CBX32M-036	11	6	2 4	CBX32M-048	12	6	0 7	CH23-68	12	5	0 0
CBX32MV-024/030	11	6	1 6	CBX32MV-048	12	6	0 8	CH33-50/60C	12	5	0 0
CBX32MV-036	15	7	3 0	CBX40UHV-042, -048	12	6	0 8	CH33-62D	12	5	0 0
CBX40UHV-024, -030	11	6	1 6	CH33-43	12	6	0 7	CX34-62C, -62D	12	7	1 0
CBX40UHV-036	15	7	3 0	CH33-62D	12	6	0 10				
C33-44C	11	6	2 3	CH33-50/60C	12	6	0 7				
CH33-36C	11	3	0 0	CH33-60D	12	6	0 4				

*Add charge = Extra matchup amount required in addition to charge indicated on Heat Pump nameplate (remember to also add any charge required for line set differences from 15 feet). **SN** indicates serial number.

Table 4. Normal Operating Pressures - Liquid ± 10 and Vapor ± 5 PSIG* (All Models)

°F (°C)**	XP14-018	XP14-024	XP14-030	XP14-036	XP14-042	XP14-048	XP14-060
	Liquid / Vapor	Liquid / Vapor	Liquid / Vapor	Liquid / Vapor	Liquid / Vapor	Liquid / Vapor	Liquid / Vapor
Heating							
60 (15)	346 / 139	352 / 138	338 / 137	350 / 134	373 / 139	355 / 130	351 / 117
50 (10)	323 / 117	331 / 114	334 / 112	331 / 117	363 / 117	336 / 113	333 / 105
40 (4)	306 / 98	304 / 99	312 / 93	313 / 97	348 / 97	315 / 88	316 / 88
30 (-1)	278 / 84	299 / 80	302 / 74	298 / 83	336 / 74	296 / 72	308 / 70
20 (-7)	273 / 66	283 / 66	280 / 53	284 / 66	322 / 64	286 / 64	300 / 61
Cooling							
65 (18)	226 / 140	233 / 137	238 / 138	220 / 138	223 / 125	231 / 136	243 / 136
70 (21)	244 / 141	252 / 138	263 / 139	236 / 140	241 / 130	248 / 139	263 / 137
75 (24)	263 / 142	271 / 140	279 / 139	256 / 141	261 / 134	271 / 140	282 / 138
80 (27)	283 / 143	292 / 141	299 / 140	276 / 142	282 / 138	291 / 142	306 / 139
85 (29)	302 / 144	314 / 142	324 / 141	298 / 143	302 / 139	312 / 143	327 / 140
90 (32)	328 / 145	338 / 143	340 / 142	321 / 144	326 / 140	335 / 144	351 / 141
95 (35)	351 / 146	361 / 145	375 / 145	344 / 144	349 / 141	359 / 145	376 / 142
100 (38)	376 / 147	387 / 146	397 / 145	369 / 146	374 / 142	384 / 146	401 / 143
105 (41)	402 / 148	412 / 147	424 / 147	394 / 147	399 / 143	411 / 148	426 / 145
110 (38)	430 / 149	441 / 148	454 / 150	421 / 148	428 / 145	439 / 149	452 / 146
115 (45)	465 / 150	471 / 151	485 / 150	449 / 149	455 / 146	468 / 150	484 / 148

***IMPORTANT**—These are most popular match-up pressures. Indoor match up, indoor air quality, and indoor load cause pressures to vary.
******Temperature of the air entering the outside coil.

Table 5. HFC-410A Temperature (°F) - Pressure (Psig)

°F	Psig	°F	Psig	°F	Psig	°F	Psig	°F	Psig	°F	Psig	°F	Psig	°F	Psig
32	100.8	48	137.1	63	178.5	79	231.6	94	290.8	110	365.0	125	445.9	141	545.6
33	102.9	49	139.6	64	181.6	80	235.3	95	295.1	111	370.0	126	451.8	142	552.3
34	105.0	50	142.2	65	184.3	81	239.0	96	299.4	112	375.1	127	457.6	143	559.1
35	107.1	51	144.8	66	187.7	82	242.7	97	303.8	113	380.2	128	463.5	144	565.9
36	109.2	52	147.4	67	190.9	83	246.5	98	308.2	114	385.4	129	469.5	145	572.8
37	111.4	53	150.1	68	194.1	84	250.3	99	312.7	115	390.7	130	475.6	146	579.8
38	113.6	54	152.8	69	197.3	85	254.1	100	317.2	116	396.0	131	481.6	147	586.8
39	115.8	55	155.5	70	200.6	86	258.0	101	321.8	117	401.3	132	487.8	148	593.8
40	118.0	56	158.2	71	203.9	87	262.0	102	326.4	118	406.7	133	494.0	149	601.0
41	120.3	57	161.0	72	207.2	88	266.0	103	331.0	119	412.2	134	500.2	150	608.1
42	122.6	58	163.9	73	210.6	89	270.0	104	335.7	120	417.7	135	506.5	151	615.4
43	125.0	59	166.7	74	214.0	90	274.1	105	340.5	121	423.2	136	512.9	152	622.7
44	127.3	60	169.6	75	217.4	91	278.2	106	345.3	122	428.8	137	519.3	153	630.1
45	129.7	61	172.6	76	220.9	92	282.3	107	350.1	123	434.5	138	525.8	154	637.5
46	132.2	62	175.4	77	224.4	93	286.5	108	355.0	124	440.2	139	532.4	155	645.0
47	134.6			78	228.0			109	360.0			140	539.0		

System Operation

The demand defrost controller measures differential temperatures to detect when the system is performing poorly because of ice build-up on the outdoor coil. The controller self-calibrates when the defrost system starts and after each system defrost cycle. The defrost control board components are shown in figure 18.

The control monitors ambient temperature, outdoor coil temperature, and total run time to determine when a defrost cycle is required. The coil temperature probe is designed with a spring clip to allow mounting to the outside coil tubing. The location of the coil sensor is important for proper defrost operation.

NOTE - The demand defrost board accurately measures the performance of the system as frost accumulates on the outdoor coil. This typically will translate into longer running time between defrost cycles as more frost accumulates on the outdoor coil before the board initiates defrost cycles.

FILTER DRIER

The unit is equipped with a large-capacity bi-flow filter drier which keeps the system clean and dry. If replacement is necessary, order another of the same design and capacity. The replacement filter drier must be suitable for use with HFC-410A refrigerant.

DEFROST CONTROL BOARD

Figure 18 provides a basic illustration of the layout of the defrost control board. Table 6 provides information concerning pin-out and jumper configurations.

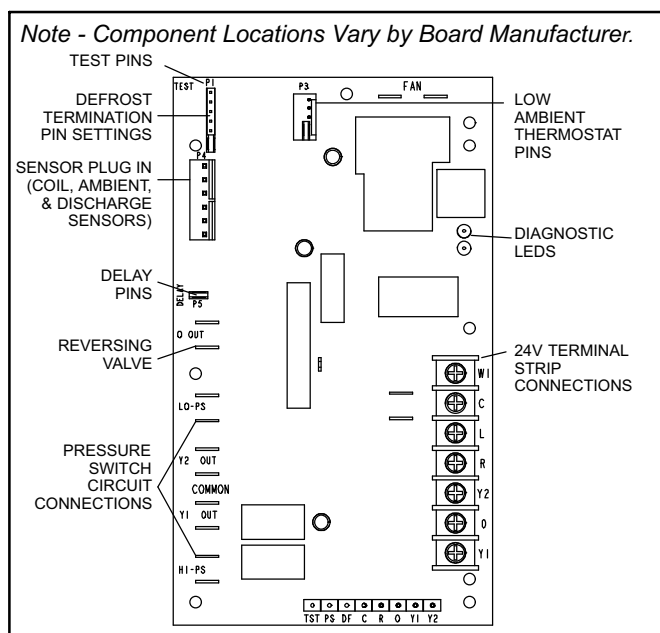

Figure 18. Defrost Control Board

Test: Defrost Temperature Termination Shunt (Jumper) Pins—The defrost board selections are: 50, 70, 90, and 100°F (10, 21, 32 and 38°C). The shunt termination pin is factory set at 50°F (10°C). If the temperature shunt is not installed, the default termination temperature is 90°F (32°C).

Note: The Y1 input must be active (ON) and the “O” room thermostat terminal into board must be inactive.

DIAGNOSTIC LEDS

The state (Off, On, Flashing) of two LEDs on the defrost board (DS1 [Red] and DS2 [Green]) indicate diagnostics conditions that are described in table 9.

DELAY MODE

The defrost board has a field-selectable function to reduce occasional sounds that may occur while the unit is cycling in and out of the defrost mode. When a jumper is installed on the DELAY pins, the compressor will be cycled off for 30 seconds going in and out of the defrost mode. Units are shipped with jumper installed on DELAY pins.

DEFROST BOARD PRESSURE SWITCH CONNECTIONS

The unit’s automatic reset pressure switches (LO PS - S87 and HI PS - S4) are factory-wired into the defrost board on the LO-PS and HI-PS terminals, respectively.

Low Pressure Switch (LO-PS)

When the low pressure switch trips, the defrost board will cycle off the compressor, and the strike counter in the board will count one strike. **Low Pressure** (auto reset) - trip at 25 psig; reset at 40 psig. The low pressure switch is ignored under the following conditions:

- during the defrost cycle and 90 seconds after the termination of defrost
- when the average ambient sensor temperature is below 15° F (-9°C)
- for 90 seconds following the start up of the compressor
- during test mode

High Pressure Switch (HI-PS)

When the high pressure switch trips, the defrost board will cycle off the compressor, and the strike counter in the board will count one strike. **High Pressure** (auto reset) - trip at 590 psig; reset at 418 psig.

Low Ambient Thermostat Pins - P3 provides selection of the Y2 compressor lock-in temperature. The XP14 series heat pumps do not use a Y2 compressor and therefore these pins are not active.

FIVE-STRIKE LOCKOUT FEATURE

The internal control logic of the board counts the pressure switch trips only while the Y1 (Input) line is active. If a pressure switch opens and closes four times during a Y1 (Input), the control logic will reset the pressure switch trip counter to zero at the end of the Y1 (Input). If the pressure switch opens for a fifth time during the current Y1 (Input), the control will enter a lockout condition.

The five-strike pressure switch lockout condition can be reset by cycling OFF the 24-volt power to the control board or by shorting the TEST pins between 1 and 2 seconds. All timer functions (run times) will also be reset.

If a pressure switch opens while the Y1 Out line is engaged, a 5-minute short cycle will occur after the switch closes.

Table 6. Defrost Control Board Description

ID	Description	
O Out	24 VAC output connection for reversing valve	
LO-PS	Connection for low-pressure switch	
Y2	24 VAC output for second stage compressor solenoid	
Y1	24 VAC common output, switched for enabling compressor contactor	
HI-PS	Connection for high-pressure switch	
P1	Seven position square pin header. P1 provides selection of the defrost terminate temperature based on the position of selection shunt, as well as selection pins for enabling the field test mode.	
P2	The following connections are provided in the seven position P2 screw terminal block:	
	W1	24 VAC thermostat output for auxiliary heat operation
	C	24 VAC system common
	L	Service light thermostat connection
	R	24 VAC system power input
	Y2	24 VAC thermostat input for second stage compressor operation
	O	24 VAC thermostat input for reversing valve operation
	Y1	24 VAC thermostat input for first stage compressor operation
P3	Five position square pin header. P3 provides selection of the Y2 compressor lock-in temperature. Note: This is applicable for two stage compressor operations only.	
P4	Six position square pin header. P4 provides connections for the temperature sensors:	
	COIL	(P4-5) Ground connection for outdoor coil temperature sensor. (P4-6) Connection for outdoor coil temperature sensor.
	AMB	(P4-3) Ground connection for outdoor ambient temperature sensor. (P4-4) Connection for outdoor ambient temperature sensor.
	DIS	(P4-1) Ground connection for discharge temperature sensor. (P4-2) Connection for discharge temperature sensor. Note: This is applicable for two stage compressor operations only.
P5	Two position square pin header. P5 provides selection of the 30-second compressor delay option.	
P6	Eight position header. P6 provides connections for the factory test connections.	

Actuation—When the reversing valve is de-energized, the Y1 circuit is energized, and the coil temperature is below 35°F (2°C), the board logs the compressor run time. If the board is not calibrated, a defrost cycle will be initiated after 30 minutes of heating mode compressor run time. The control will attempt to self-calibrate after this (and all other) defrost cycle(s).

Calibration success depends on stable system temperatures during the 20-minute calibration period. If the board fails to calibrate, another defrost cycle will be initiated after 45 minutes of heating mode compressor run time. Once the defrost board is calibrated, it initiates a demand defrost cycle when the difference between the clear coil and frosted coil temperatures exceeds the maximum difference allowed by the control OR after 6 hours of heating mode compressor run time has been logged since the last defrost cycle.

NOTE - If ambient or coil sensor fault is detected, the board will not execute the TEST mode.

Termination—The defrost cycle ends when the coil temperature exceeds the termination temperature or after 14 minutes of defrost operation. If the defrost is terminated by the 14-minute timer, another defrost cycle will be initiated after 30 minutes of run time.

Each test pin shorting will result in one test event. For each TEST the shunt (jumper) must be removed for at least one second and reapplied. Refer to flow chart as illustrated in figure 19 for TEST operation.

Test Mode—When Y1 is energized and 24V power is being applied to the board, a test cycle can be initiated by placing the termination temperature jumper across the TEST pins for two to five seconds. If the jumper remains across the TEST pins longer than five seconds, the control will ignore the TEST pins and revert to normal operation. The jumper will initiate one cycle per test.

Table 7. Sensor Temperature / Resistance Range

Sensor	Temperature Range °F (°C)	Resistance Values Range (ohms)	Pins/Wire Color
Outdoor (Ambient)	-35 to 120 (-37) to (48)	280,000 to 3750	3 and 4 (Black)
Coil	-35 to 120 (-37) to (48)	280,000 to 3750	5 and 6 (Brown)

Note: Sensor resistance decreases as sensed temperature increases.

Enter the TEST mode by placing a shunt (jumper) across the TEST pins on the board **after** power-up. The TEST pins are ignored and the test function is locked out if the shunt is applied on the TEST pins before power-up. Board timings are reduced, the low-pressure switch is ignored and the board will clear any active lockout condition.

NOTE - The 30-second off cycle is NOT functional when jumpering the TEST pins.

Ambient Sensor—The ambient sensor (shown in figure 1) considers outdoor temperatures below -35°F (-37°C) or above 120°F (48°C) as a fault. If the ambient sensor is detected as being open, shorted or out of the temperature range of the sensor, the board will not perform demand defrost operation. The board will revert to time/temperature defrost operation and will display the appropriate fault code. Heating and cooling operation will be allowed in this fault condition.

Coil Sensor—The coil temperature sensor (shown in figure 1) considers outdoor temperatures below -35°F (-37°C) or above 120°F (48°C) as a fault. If the coil temperature sensor is detected as being open, shorted or out of the temperature range of the sensor, the board will not perform demand or time/temperature defrost operation and will display the appropriate fault code. Heating and cooling operation will be allowed in this fault condition.

Defrost System

The defrost control board has three basic operational modes: normal, calibration, and defrost.

Normal Mode—The demand defrost board monitors the O line, to determine the system operating mode (heat/cool), outdoor ambient temperature, coil temperature (outdoor coil) and compressor run time to determine when a defrost cycle is required.

Calibration Mode—The board is considered uncalibrated when power is applied to the board, after cool mode operation, or if the coil temperature exceeds the termination temperature when it is in heat mode.

Calibration of the board occurs after a defrost cycle to ensure that there is no ice on the coil. During calibration, the temperature of both the coil and the ambient sensor are measured to establish the temperature differential which is required to allow a defrost cycle.

Defrost Mode—The following paragraphs provide a detailed description of the defrost system operation.

Defrost Cycles—The demand defrost control board initiates a defrost cycle based on either frost detection or time.

- **Frost Detection**—If the compressor runs longer than 30 minutes and the actual difference between the clear coil and frosted coil temperatures exceeds the maximum difference allowed by the control, a defrost cycle will be initiated.

IMPORTANT - The demand defrost control board will allow a greater accumulation of frost and will initiate fewer defrost cycles than a time/temperature defrost system.

- **Time**—If six hours of heating mode compressor run time has elapsed since the last defrost cycle while the coil temperature remains below 35°F (2°C), the demand defrost control will initiate a defrost cycle.

Table 8. Ambient (RT13) and Coil (RT21) Sensors Temperature / Resistance Range

Degrees Fahrenheit	Resistance	Degrees Fahrenheit	Resistance	Degrees Fahrenheit	Resistance	Degrees Fahrenheit	Resistance
136.3	2680	56.8	16657	21.6	44154	-11.3	123152
133.1	2859	56.0	16973	21.0	44851	-11.9	125787
130.1	3040	55.3	17293	20.5	45560	-12.6	128508
127.3	3223	54.6	17616	20.0	46281	-13.2	131320
124.7	3407	53.9	17942	19.4	47014	-13.9	134227
122.1	3592	53.2	18273	18.9	47759	-14.5	137234
119.7	3779	52.5	18607	18.4	48517	-15.2	140347
117.5	3968	51.9	18945	17.8	49289	-15.9	143571
115.3	4159	51.2	19287	17.3	50074	-16.5	146913
113.2	4351	50.5	19633	16.8	50873	-17.2	150378
111.2	4544	49.9	19982	16.3	51686	-17.9	153974
109.3	4740	49.2	20336	15.7	52514	-18.6	157708
107.4	4937	48.5	20695	15.2	53356	-19.3	161588
105.6	5136	47.9	21057	14.7	54215	-20.1	165624
103.9	5336	47.3	21424	14.1	55089	-20.8	169824
102.3	5539	46.6	21795	13.6	55979	-21.5	174200
100.6	5743	46.0	22171	13.1	56887	-22.3	178762
99.1	5949	45.4	22551	12.5	57811	-23.0	183522
97.6	6157	44.7	22936	12.0	58754	-23.8	188493
96.1	6367	44.1	23326	11.5	59715	-24.6	193691
94.7	6578	43.5	23720	11.0	60694	-25.4	199130
93.3	6792	42.9	24120	10.4	61693	-26.2	204829
92.0	7007	42.3	24525	9.9	62712	-27.0	210805
90.6	7225	41.7	24934	9.3	63752	-27.8	217080
89.4	7444	41.1	25349	8.8	64812	-28.7	223677
88.1	7666	40.5	25769	8.3	65895	-29.5	230621
86.9	7890	39.9	26195	7.7	67000	-30.4	237941
85.7	8115	39.3	26626	7.2	68128	-31.3	245667
84.5	8343	38.7	27063	6.7	69281	-32.2	253834
83.4	8573	38.1	27505	6.1	70458	-33.2	262482
82.3	8806	37.5	27954	5.6	71661	-34.1	271655
81.2	9040	37.0	28408	5.0	72890	-35.1	281400
80.1	9277	36.4	28868	4.5	74147	-36.1	291774
79.0	9516	35.8	29335	3.9	75431	-37.1	302840
78.0	9757	35.2	29808	3.4	76745	-38.2	314669
77.0	10001	34.7	30288	2.8	78090	-39.2	327343
76.0	10247	34.1	30774	2.3	79465		
75.0	10496	33.5	31267	1.7	80873		
74.1	10747	33.0	31766	1.2	82314		
73.1	11000	32.4	32273	0.6	83790		
72.2	11256	31.9	32787	0.0	85302		
71.3	11515	31.3	33309	-0.5	86852		
70.4	11776	30.7	33837	-1.1	88440		
69.5	12040	30.2	34374	-1.7	90068		
68.6	12306	29.6	34918	-2.2	91738		
67.7	12575	29.1	35471	-2.8	93452		
66.9	12847	28.6	36031	-3.4	95211		
66.0	13122	28.0	36600	-4.0	97016		
65.2	13400	27.5	37177	-4.6	98870		
64.4	13681	26.9	37764	-5.2	100775		
63.6	13964	26.4	38359	-5.7	102733		
62.8	14251	25.8	38963	-6.3	104746		
62.0	14540	25.3	39577	-6.9	106817		
61.2	14833	24.8	40200	-7.5	108948		
60.5	15129	24.2	40833	-8.2	111141		
59.7	15428	23.7	41476	-8.8	113400		
59.0	15730	23.2	42130	-9.4	115727		
58.2	16036	22.6	42794	-10.0	118126		
57.5	16345	22.1	43468	-10.6	120600		

TEST

Placing the jumper on the field test pins (E33) allows the technician to:

- Clear short cycle lockout
- Clear five-strike fault lockout
- Cycle the unit in and out of defrost mode
- Place the unit in defrost mode to clear the coil

When Y1 is energized and 24V power is being applied to the Control, a test cycle can be initiated by placing a jumper on the Control's TEST pins for 2 to 5 seconds. If the jumper remains on the TEST pins for longer than five seconds, the Control will ignore the jumpered TEST pins and revert to normal operation.

The Control will initiate one test event each time a jumper is placed on the TEST pins. For each TEST the jumper must be removed for at least one second and then reapplied.

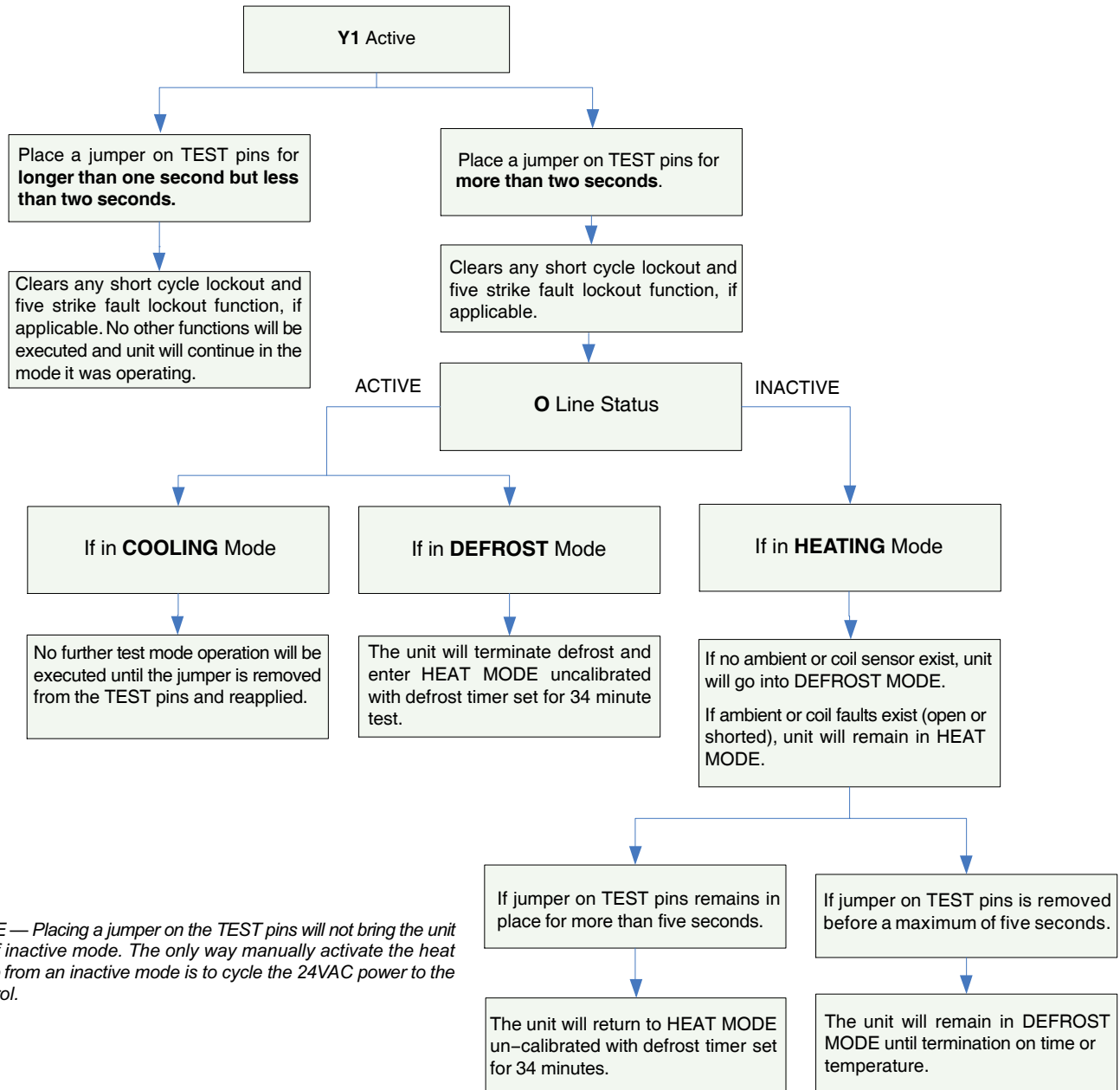
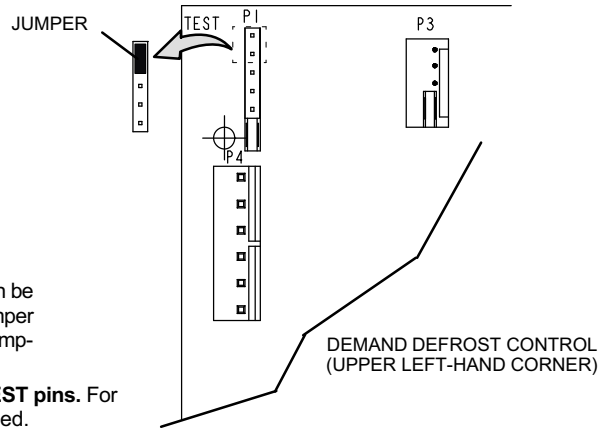

NOTE — Placing a jumper on the TEST pins will not bring the unit out of inactive mode. The only way manually activate the heat pump from an inactive mode is to cycle the 24VAC power to the Control.

Figure 19. Test Mode

DEFROST BOARD DIAGNOSTICS

See table 9 to determine defrost board operational conditions and to diagnose cause and solution to problems.

Table 9. Defrost Control Board Diagnostic LEDs

DS2 Green	DS1 Red	Condition/Code	Possible Cause(s)	Solution
OFF	OFF	Power problem	No power (24V) to board terminals R and C or board failure.	1 Check control transformer power (24V). 2 If power is available to board and LED(s) do not light, replace board.
Simultaneous SLOW Flash		Normal operation	Unit operating normally or in standby mode.	None required.
Alternating SLOW Flash		5-minute anti-short cycle delay	Initial power up, safety trip, end of room thermostat demand.	None required (Jumper TEST pins to override)
Simultaneous FAST Flash		Ambient Sensor Problem	Sensor being detected open or shorted or out of temperature range. Board will revert to time/temperature defrost operation. (System will still heat or cool).	
Alternating FAST Flash		Coil Sensor Problem	Sensor being detected open or shorted or out of temperature range. Board will not perform demand or time/temperature defrost operation. (System will still heat or cool).	
ON	ON	Circuit Board Failure	Indicates that board has internal component failure. Cycle 24 volt power to board. If code does not clear, replace board.	

FAULT and LOCKOUT CODES (Each fault adds 1 strike to that code's counter; 5 strikes per code = LOCKOUT)

OFF	SLOW Flash	Low Pressure Fault	1 Restricted air flow over indoor or outdoor coil. 2 Improper refrigerant charge in system. 3 Improper metering device installed or incorrect operation of metering device. 4 Incorrect or improper sensor location or connection to system.	1 Remove any blockages or restrictions from coils and/or fans. Check indoor and outdoor fan motor for proper current draws. 2 Check system charge using approach and subcooling temperatures. 3 Check system operating pressures and compare to unit charging charts. 4 Make sure all pressure switches and sensors have secure connections to system to prevent refrigerant leaks or errors in pressure and temperature measurements.
OFF	ON	Low Pressure LOCKOUT		
SLOW Flash	OFF	High Pressure Fault		
ON	OFF	High Pressure LOCKOUT		
SLOW Flash	ON	Discharge Line Temperature Fault	This model does not have a defrost line sensor, therefore this code is not applicable.	
FAST Flash	ON	Discharge Line Temperature LOCKOUT		
OFF	Fast Flash	Discharge Sensor Fault	The XP14 series units does not use a defrost line sensor. However, a resistor is installed across pins P4-1 and P4-2. If the resistor is missing or damage then this fault code will be displayed.	
Fast Flash	OFF	Discharge Sensor LOCKOUT	This model does not have a defrost line sensor, therefore this code is not applicable.	

Maintenance

Maintenance and service must be performed by a qualified installer or service agency. At the beginning of each cooling season, the system should be checked as follows:

Outdoor Unit

- Clean and inspect the outdoor coil. The coil may be flushed with a water hose. Ensure the power is turned off before you clean the coil.
- Outdoor fan motor is prelubricated and sealed. No further lubrication is needed.
- Visually inspect connecting lines and coils for evidence of oil leaks.
- Check wiring for loose connections.
- Check for correct voltage at the unit (with the unit operating).
- Check amp-draw outdoor fan motor.

UNIT NAMEPLATE: _____ ACTUAL: _____

NOTE - If owner reports insufficient cooling, the unit should be gauged and refrigerant charge checked.

Outdoor Coil

It may be necessary to flush the outdoor coil more frequently if it is exposed to substances which are corrosive or which block airflow across the coil (e.g., pet urine, cottonwood seeds, fertilizers, fluids that may contain high levels of corrosive chemicals such as salts)

- Outdoor Coil — The outdoor coil may be flushed with a water hose.
- Outdoor Coil (Sea Coast) — Moist air in ocean locations can carry salt, which is corrosive to most metal. Units that are located near the ocean require frequent inspections and maintenance. These inspections will determine the necessary need to wash the unit including the outdoor coil. Consult your installing contractor for proper intervals/procedures for your geographic area or service contract.

SEQUENCE OF OPERATIONS

This is the sequence of operation for XP14 series units. The sequence is outlined by numbered steps which correspond to circled numbers on the adjacent diagram. The steps are identical for both cooling and first stage heating demand with the exception reversing valve L1 is energized during cooling demand and de-energized during heating demand.

NOTE- Transformer in indoor unit supplies power (24 VAC) to the thermostat and outdoor unit controls.

COOLING:

Internal thermostat wiring energizes terminal O by cooling mode selection, energizing the reversing valve L1.

1. Demand initiates at Y1 in the thermostat.
2. 24VAC energizes compressor contactor K1.
3. K1-1 N.O. closes, energizing compressor (B1) and outdoor fan motor (B4).

END OF COOLING DEMAND:

1. Demand is satisfied. Terminal Y1 is de-energized.
2. Compressor contactor K1 is de-energized.
3. K1-1 opens and compressor (B1) and outdoor fan motor (B4) are de-energized and stop immediately.

FIRST STAGE HEAT:

Internal thermostat wiring de-energizes terminal O by heating mode selection, de-energizing the reversing valve L1.

See steps 1, 2 and 3.

END OF FIRST STAGE HEAT:

See steps 4, 5 and 6.

DEFROST MODE:

When a defrost cycle is initiated, the control energizes the reversing valve solenoid and turns off the condenser fan. The control will also put 24VAC on the "W1" (auxiliary heat) line. The unit will stay in this mode until either the coil sensor temperature is above the selected termination temperature, the defrost time of 14 minutes has been completed, or the room thermostat demand cycle has been satisfied. (If the temperature select shunt is not installed, the default termination temperature will be 90°F.) If the room thermostat demand cycle terminates the cycle, the defrost cycle will be held until the next room thermostat demand cycle. If the coil sensor temperature is still below the selected termination temperature, the control will continue the defrost cycle until the cycle is terminated in one of the methods mentioned above. If a defrost is terminated by time and the coil temperature did not remain above 35°F (2°C) for 4 minutes the control will go to the 30-minute Time/Temperature mode.

Start-Up and Performance Checklist		
Job Name _____	Job no. _____	Date _____
Job Location _____	City _____	State _____
Installer _____	City _____	State _____
Unit Model No. _____	Serial No. _____	Service Technician _____
Nameplate Voltage _____		
Rated Load Ampacity _____ Compressor Amperage: _____		
Maximum Fuse or Circuit Breaker _____		
Electrical Connections Tight? <input type="checkbox"/>	Indoor Filter clean? <input type="checkbox"/>	Supply Voltage (Unit Off) _____
Indoor Blower RPM _____	S.P. Drop Over Indoor (Dry) _____	Outdoor Coil Entering Air Temp. _____
Vapor Pressure; _____		
Refrigerant Lines: - Leak Checked? <input type="checkbox"/>	Properly Insulated? <input type="checkbox"/>	Outdoor Fan Checked? <input type="checkbox"/>
Service Valves: --- Fully Opened? <input type="checkbox"/>	Caps Tight? <input type="checkbox"/>	Voltage With Compressor Operating _____
SEQUENCE OF OPERATION		THERMOSTAT
Heating Correct? <input type="checkbox"/>	Cooling Correct? <input type="checkbox"/>	Calibrated? <input type="checkbox"/> Properly Set? <input type="checkbox"/> Level? <input type="checkbox"/>