

**XC13 (HFC-410A) SERIES UNITS**



**TABLE OF CONTENTS**

Model Number Identification .....	2
Typical Serial Number Identification .....	2
Specifications .....	2
Electrical Data .....	3
Unit Dimensions .....	5
Unit Parts Arrangement .....	6
Operating Gauge Set and Service Valves .....	7
Recovering Refrigerant from System .....	9
Unit Placement .....	10
Removing and Installing Panels .....	12
New or Replacement Line Set .....	14
Brazing Connections .....	16
Flushing Line Set and Indoor Coil .....	19
Installing Indoor Metering Device .....	20
Leak Test Line Set and Indoor Coil .....	21
Evacuating Line Set and Indoor Coil .....	22
Electrical .....	23
Servicing Units Void of Charge .....	24
Unit Start-Up .....	24
System Refrigerant .....	24
System Operation .....	32
Maintenance .....	32
Start-Up and Performance Checklist .....	33
Unit Wiring Diagrams and Sequence of Operations .....	34

The XC13 Air Conditioners, which will also be referred to in this instruction as the outdoor unit, uses HFC-410A refrigerant. This outdoor unit must be installed with a matching indoor unit and line set as outlined in the *Lennox XC13 Engineering Handbook*. This unit is designed for systems that use either a fixed orifice or expansion valve.

**⚠ WARNING**

Improper installation, adjustment, alteration, service or maintenance can cause personal injury, loss of life, or damage to property.

Installation and service must be performed by a licensed professional installer (or equivalent) or a service agency.

**⚠ CAUTION**

Physical contact with metal edges and corners while applying excessive force or rapid motion can result in personal injury. Be aware of, and use caution when working near these areas during installation or while servicing this equipment.

**⚠ IMPORTANT**

The Clean Air Act of 1990 bans the intentional venting of refrigerant (CFCs, HCFCs and HFCs) as of July 1, 1992. Approved methods of recovery, recycling or reclaiming must be followed. Fines and/or incarceration may be levied for noncompliance.

**⚠ IMPORTANT**

This unit must be matched with an indoor coil as specified in *Lennox XC13 Engineering Handbook*. Coils previously charged with HCFC-22 must be flushed.

## Model Number Identification

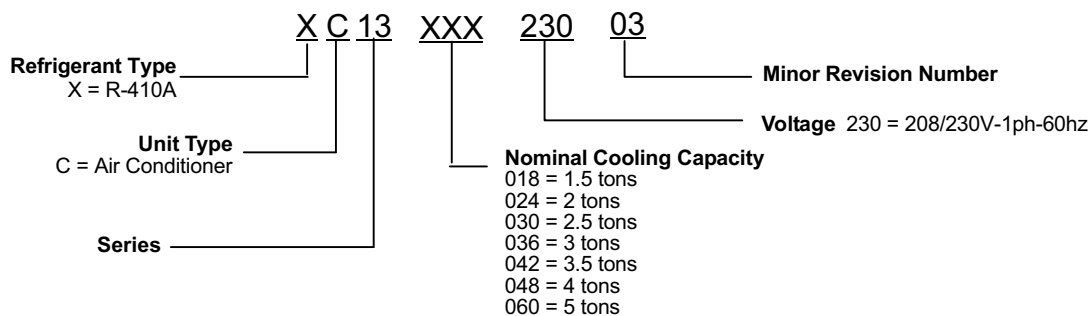

## Typical Serial Number Identification

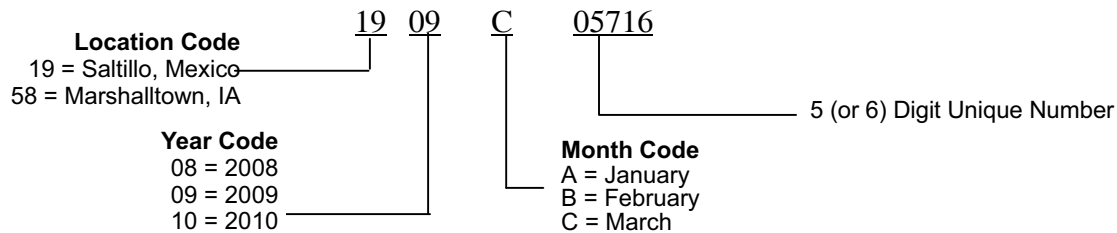

## Specifications

Model Number	Unit		Outdoor Fan	
	Sound Rating Number (dB) <sup>1</sup>	Factory Refrigerant Charge <sup>2</sup>	Number of Blades	Diameter - inches.
XC13-018-230-01	74	4 lbs. 10 oz.	3	18
XC13-018-230-02	74	3 lbs. 13 oz.	3	18
XC13-018-230-03	74	3 lbs. 13 oz.	3	18

Model Number	Unit		Outdoor Fan	
	Sound Rating Number (dB) <sup>1</sup>	Factory Refrigerant Charge <sup>2</sup>	Number of Blades	Diameter - inches.
XC13-024-230-01	74	5 lbs. 6 oz.	3	18
XC13-024-230-02	74	4 lbs. 6 oz.	3	18
XC13-024-230-04	74	4 lbs. 6 oz.	3	18

Model Number	Unit		Outdoor Fan	
	Sound Rating Number (dB) <sup>1</sup>	Factory Refrigerant Charge <sup>2</sup>	Number of Blades	Diameter - inches.
XC13-030-230-01	76	7 lbs. 2 oz.	3	18
XC13-030-230-02	76	7 lbs. 2 oz.	3	18
XC13-030-230-03	76	4 lbs. 4 oz.	3	18
XC13-030-230-04	76	4 lbs. 4 oz.	3	18

Model Number	Unit		Outdoor Fan	
	Sound Rating Number (dB) <sup>1</sup>	Factory Refrigerant Charge <sup>2</sup>	Number of Blades	Diameter - inches.
XC13-036-230-01	76	7 lbs. 4 oz.	3	22
XC13-036-230-02	76	7 lbs. 4 oz.	3	22
XC13-036-230-03	76	5 lbs. 9 oz.	3	18
XC13-036-230-04	76	5 lbs. 9 oz.	3	18

Model Number	Unit		Outdoor Fan	
	Sound Rating Number (dB) <sup>1</sup>	Factory Refrigerant Charge <sup>2</sup>	Number of Blades	Diameter - inches.
XC13-042-230-01	76	8 lbs. 10 oz.	3	22
XC13-042-230-02	76	8 lbs. 10 oz.	3	22
XC13-042-230-03	76	6 lbs. 9 oz.	3	22
XC13-042-230-04	76	6 lbs. 9 oz.	3	22

Model Number	Unit		Outdoor Fan	
	Sound Rating Number (dB) <sup>1</sup>	Factory Refrigerant Charge <sup>2</sup>	Number of Blades	Diameter - inches.
XC13-048-230-01	76	9 lbs. 2 oz.	3	22
XC13-048-230-02	76	9 lbs. 2 oz.	3	22
XC13-048-230-03	76	7 lbs. 8 oz.	3	22
XC13-048-230-04	76	7 lbs. 8 oz.	3	22

Model Number	Unit		Outdoor Fan	
	Sound Rating Number (dB) <sup>1</sup>	Factory Refrigerant Charge <sup>2</sup>	Number of Blades	Diameter - inches.
XC13-060-230-01	76	12 lbs. 6 oz.	3	22
XC13-060-230-02	76	12 lbs. 6 oz.	3	22
XC13-060-230-03	76	10 lbs. 0 oz.	3	22
XC13-060-230-04	76	10 lbs. 0 oz.	3	22
XC13-060-230-05	76	10 lbs. 0 oz.	3	22

<sup>1</sup> Tested according to AHRI Standard 270-2008 test conditions.

<sup>2</sup> Refrigerant charge sufficient for 15 feet length of refrigerant lines.

## Electrical Data

208/230V-60 Hz-1 Ph

Model Number	Unit		Compressor		Condenser Fan			
	Maximum Over-current Protection (amps) <sup>1</sup>	Minimum Circuitry Ampacity <sup>2</sup>	Rated Load Amps (RLA)	Locked Rotor Amps (LRA)	Motor HP	Nominal RPM	Full Load Amps (FLA)	Locked Rotor Amps (LRA)
XC13-018-230-01	20	11.9	8.97	48.0	1/10	1075	0.7	1.4
XC13-018-230-02	20	11.9	8.97	48.0	1/10	1075	0.7	1.4
XC13-018-230-03	20	11.9	8.97	48.0	1/10	1075	0.7	1.4

208/230V-60 Hz-1 Ph

Model Number	Unit		Compressor		Condenser Fan			
	Maximum Over-current Protection (amps) <sup>1</sup>	Minimum Circuitry Ampacity <sup>2</sup>	Rated Load Amps (RLA)	Locked Rotor Amps (LRA)	Motor HP	Nominal RPM	Full Load Amps (FLA)	Locked Rotor Amps (LRA)
XC13-024-230-01	30	17.5	13.46	58.0	1/10	1075	0.7	1.4
XC13-024-230-02	30	17.5	13.46	58.0	1/10	1075	0.7	1.4
XC13-024-230-04	30	17.5	13.46	53.0	1/10	1075	0.7	1.4

208/230V-60 Hz-1 Ph

Model Number	Unit		Compressor		Condenser Fan			
	Maximum Over-current Protection (amps) <sup>1</sup>	Minimum Circuitry Ampacity <sup>2</sup>	Rated Load Amps (RLA)	Locked Rotor Amps (LRA)	Motor HP	Nominal RPM	Full Load Amps (FLA)	Locked Rotor Amps (LRA)
XC13-030-230-01	30	18.7	14.10	73.0	1/5	1075	1.1	2.0
XC13-030-230-02	30	18.4	14.10	73.0	1/10	1075	0.7	1.4
XC13-030-230-03	30	18.7	14.10	73.0	1/5	1075	1.1	2.0
XC13-030-230-04	30	18.7	14.10	59.0	1/5	1075	1.1	2.0

## 208/230V-60 Hz-1 Ph

Model Number	Unit		Compressor		Condenser Fan			
	Maximum Over-current Protection (amps) <sup>1</sup>	Minimum Circuitry Ampacity <sup>2</sup>	Rated Load Amps (RLA)	Locked Rotor Amps (LRA)	Motor HP	Nominal RPM	Full Load Amps (FLA)	Locked Rotor Amps (LRA)
XC13-036-230-01	35	21.9	16.67	79.0	1/5	1075	1.1	2.0
XC13-036-230-02	35	21.9	16.67	79.0	1/5	1075	1.1	2.0
XC13-036-230-03	40	24.35	18.6	79.0	1/5	1075	1.1	2.0
XC13-036-230-04	40	24.35	18.6	70.0	1/5	1075	1.1	2.0

## 208/230V-60 Hz-1 Ph

Model Number	Unit		Compressor		Condenser Fan			
	Maximum Over-current Protection (amps) <sup>1</sup>	Minimum Circuitry Ampacity <sup>2</sup>	Rated Load Amps (RLA)	Locked Rotor Amps (LRA)	Motor HP	Nominal RPM	Full Load Amps (FLA)	Locked Rotor Amps (LRA)
XC13-042-230-01	40	23.2	17.69	107.0	1/6	825	1.1	2.1
XC13-042-230-02	40	24.1	17.95	107.0	1/6	825	1.1	2.0
XC13-042-230-03	40	24.1	17.95	112.0	1/4	825	1.7	3.1
XC13-042-230-04	40	25.3	18.8	90.0	1/4	825	1.7	3.1

## 208/230V-60 Hz-1 Ph

Model Number	Unit		Compressor		Condenser Fan			
	Maximum Over-current Protection (amps) <sup>1</sup>	Minimum Circuitry Ampacity <sup>2</sup>	Rated Load Amps (RLA)	Locked Rotor Amps (LRA)	Motor HP	Nominal RPM	Full Load Amps (FLA)	Locked Rotor Amps (LRA)
XC13-048-230-01	50	28.3	21.79	117.0	1/6	825	1.1	2.1
XC13-048-230-02	50	28.3	21.79	117.0	1/6	825	1.1	2.1
XC13-048-230-03	50	28.9	21.79	117.0	1/4	825	1.7	3.1
XC13-048-230-04	50	28.9	21.79	100.0	1/4	825	1.7	3.1

## 208/230V-60 Hz-1 Ph

Model Number	Unit		Compressor		Condenser Fan			
	Maximum Over-current Protection (amps) <sup>1</sup>	Minimum Circuitry Ampacity <sup>2</sup>	Rated Load Amps (RLA)	Locked Rotor Amps (LRA)	Motor HP	Nominal RPM	Full Load Amps (FLA)	Locked Rotor Amps (LRA)
XC13-060-230-01	60	34.6	26.28	134.0	1/4	825	1.7	3.1
XC13-060-230-02	60	34.6	26.28	134.0	1/4	825	1.7	2.1
XC13-060-230-03	60	34.6	26.28	134.0	1/4	825	1.7	3.1
XC13-060-230-04	60	34.6	26.28	134.0	1/4	825	1.7	3.1
XC13-060-230-05	60	34.6	26.28	120.0	1/4	825	1.7	3.1

<sup>1</sup> HACR type circuit breaker or fuse.

<sup>2</sup> Refer to National or Canadian Electrical Code manual to determine wire, fuse and disconnect size requirements.

## Unit Dimensions - Inches (mm)

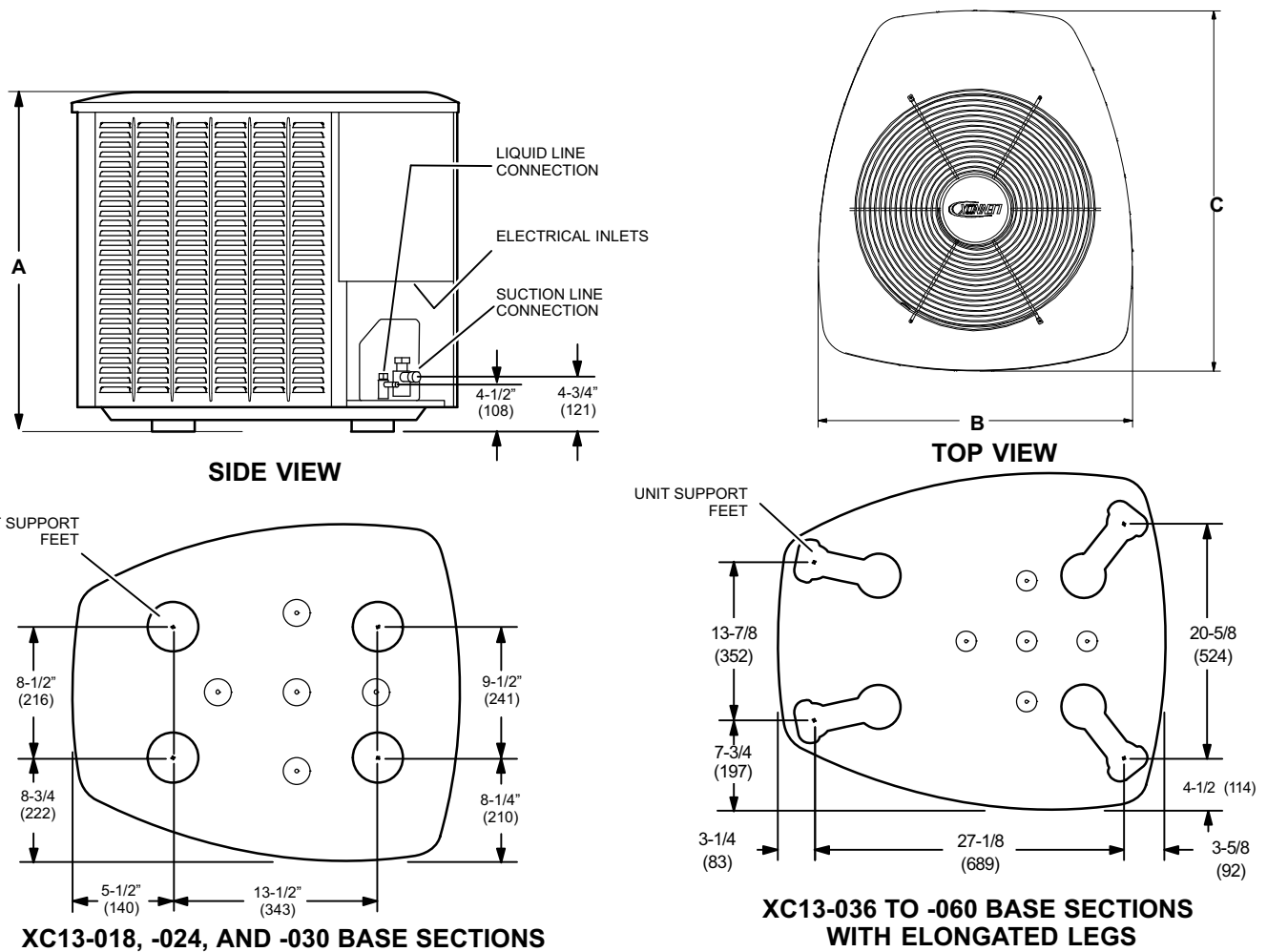

Model Numbers	A	B	C
XC13-018-230-01	31 (787)	27 (686)	28 (711)
XC13-018-230-02 and later	27 (686)	27 (686)	28 (711)
XC13-024-230-01	35 (889)	27 (686)	28 (711)
XC13-024-230-02 and later	27 (686)	27 (686)	28 (711)
XC13-030-230 (All)	31 (787)	27 (686)	28 (711)
XC13-036-230-01 and -02	35 (889)	30-1/2 (775)	35 (889)
XC13-036-230-03	31 (787)	27 (686)	28 (711)
XC13-042-230-01 and -02	31 (787)	30-1/2 (775)	35 (889)
XC13-042-230-03	39 (991)	31 (787)	35 (889)
XC13-048-230-01 and -02	31 (787)	30-1/2 (775)	35 (889)
XC13-048-230-03	39 (991)	30-1/2 (775)	35 (889)
XC13-060-230-01, -02 and -03	45 (1143)	30-1/2 (775)	35 (889)
XC13-060-04	35 (889)	30-1/2 (775)	35 (889)

# Typical Unit Parts Arrangement

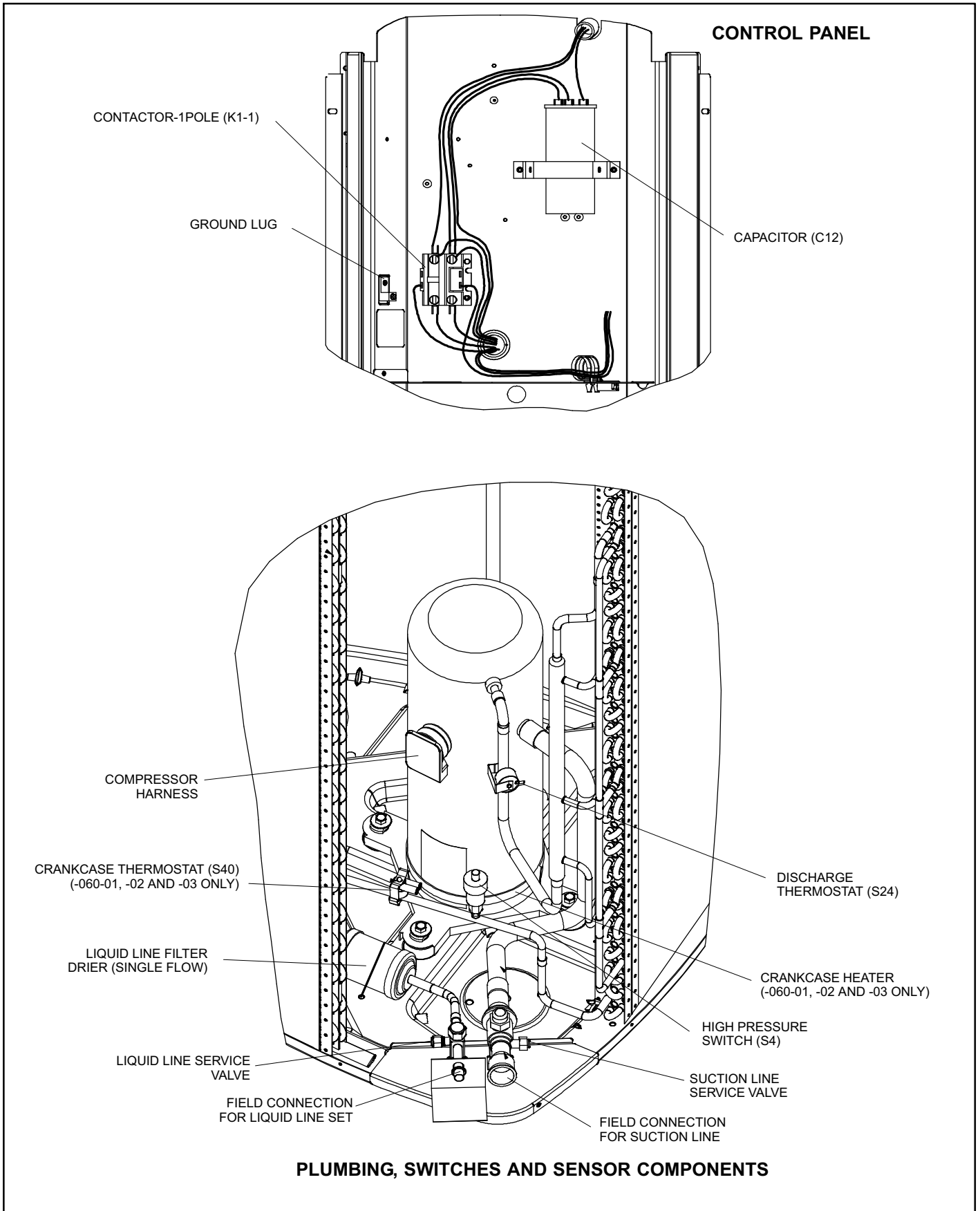

Figure 1. Typical Parts Arrangements

## **WARNING**

This product and/or the indoor unit it is matched with may contain fiberglass wool.

Disturbing the insulation during installation, maintenance, or repair will expose you to fiberglass wool dust. Breathing this may cause lung cancer. (Fiberglass wool is known to the State of California to cause cancer.)

Fiberglass wool may also cause respiratory, skin, and eye irritation.

To reduce exposure to this substance or for further information, consult material safety data sheets available from address shown below, or contact your supervisor.

Lennox Industries Inc.  
P.O. Box 799900  
Dallas, TX 75379-9900

## **WARNING**



**Electric Shock Hazard.** Can cause injury or death. Unit must be grounded in accordance with national and local codes.

Line voltage is present at all components when unit is not in operation on units with single-pole contactors. Disconnect all remote electric power supplies before opening access panel. Unit may have multiple power supplies.

## **Operating Gauge Set and Service Valves**

These instructions are intended as a general guide and do not supersede local codes in any way. Consult authorities who have jurisdiction before installation.

### **TORQUE REQUIREMENTS**

When servicing or repairing heating, ventilating, and air conditioning components, ensure the fasteners are appropriately tightened. Table 1 lists torque values for fasteners.

## **IMPORTANT**

Only use Allen wrenches of sufficient hardness (50Rc - Rockwell Harness Scale minimum). Fully insert the wrench into the valve stem recess.

Service valve stems are factory-torqued (from 9 ft-lbs for small valves, to 25 ft-lbs for large valves) to prevent refrigerant loss during shipping and handling. Using an Allen wrench rated at less than 50Rc risks rounding or breaking off the wrench, or stripping the valve stem recess.

See the Lennox Service and Application Notes #C-08-1 for further details and information.

## **IMPORTANT**

To prevent stripping of the various caps used, the appropriately sized wrench should be used and fitted snugly over the cap before tightening.

**Table 1. Torque Requirements**

Parts	Recommended Torque	
Service valve cap	8 ft.- lb.	11 NM
Sheet metal screws	16 in.- lb.	2 NM
Machine screws #10	28 in.- lb.	3 NM
Compressor bolts	90 in.- lb.	10 NM
Gauge port seal cap	8 ft.- lb.	11 NM

### **USING MANIFOLD GAUGE SET**

When checking the system charge, only use a manifold gauge set that features low loss anti-blow back fittings.

Manifold gauge set used with HFC-410A refrigerant systems must be capable of handling the higher system operating pressures. The gauges should be rated for use with pressures of 0 - 800 psig on the high side and a low side of 30" vacuum to 250 psig with dampened speed to 500 psi. Gauge hoses must be rated for use at up to 800 psig of pressure with a 4000 psig burst rating.

### **OPERATING SERVICE VALVES**

The liquid and vapor line service valves are used for removing refrigerant, flushing, leak testing, evacuating, checking charge and charging.

Each valve is equipped with a service port which has a factory-installed valve stem. Figure 2 provides information on how to access and operating both angle and ball service valves.

# SERVICE VALVES ANGLE AND BALL

## Operating Angle Type Service Valve:

1. Remove stem cap with an appropriately sized wrench.
2. Use a service wrench with a hex-head extension (3/16" for liquid line valve sizes and 5/16" for vapor line valve sizes) to back the stem out counterclockwise as far as it will go.

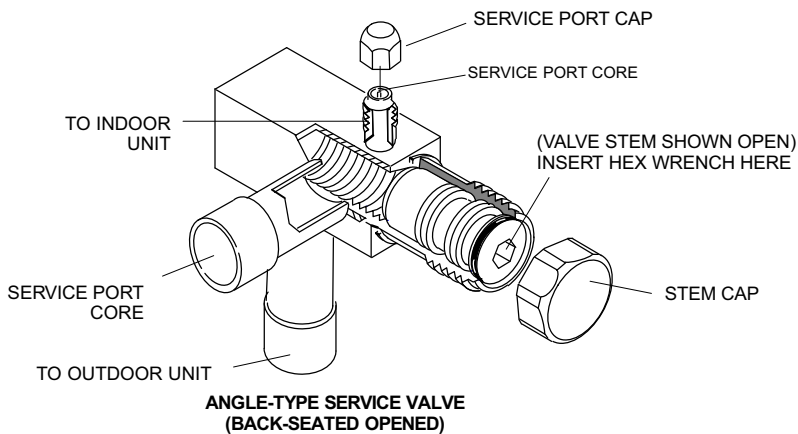

When service valve is **OPEN**, the service port is open to line set, indoor and outdoor unit.

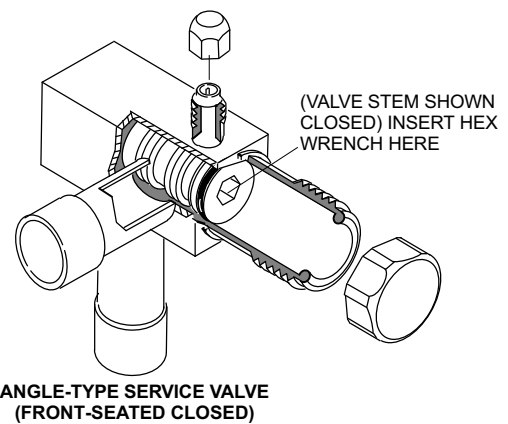

WHEN SERVICE VALVE IS **CLOSED**, THE SERVICE PORT IS OPEN TO THE LINE SET AND INDOOR UNIT.

## Operating Ball Type Service Valve:

1. Remove stem cap with an appropriately sized wrench.
2. Use an appropriately sized wrench to open. To open valve, rotate stem counterclockwise 90°. To close rotate stem clockwise 90°.

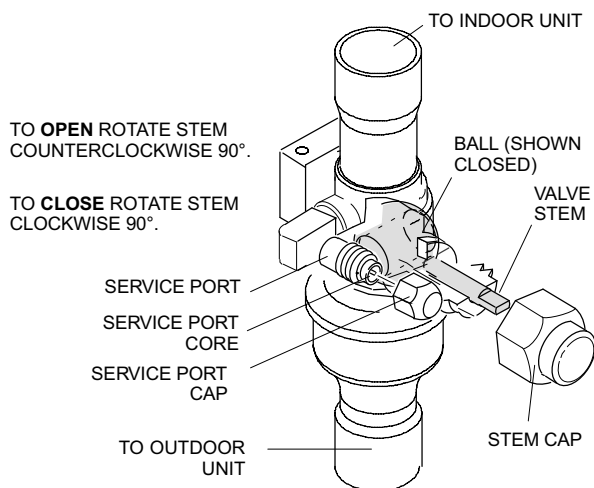

## To Access Service Port:

A service port cap protects the service port core from contamination and serves as the primary leak seal.

1. Remove service port cap with an appropriately sized wrench.
2. Connect gauge set to service port.
3. When testing is completed, replace service port cap and tighten as follows:
  - With torque wrench: Finger tighten and torque cap per table 1.
  - Without torque wrench: Finger tighten and use an appropriately sized wrench to turn an additional 1/6 turn clockwise.

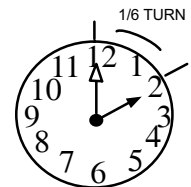

## Reinstall Stem Cap:

Stem cap protects the valve stem from damage and serves as the primary seal. Replace the stem cap and tighten as follows:

- With Torque Wrench: Finger tighten and then torque cap per table 1.
- Without Torque Wrench: Finger tighten and use an appropriately sized wrench to turn an additional 1/12 turn clockwise.

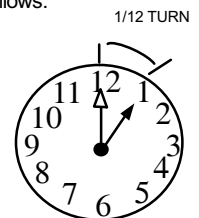

NOTE — A label with specific torque requirements may be affixed to the stem cap. If the label is present, use the specified torque.

Figure 2. Angle and Ball Service Valves



## Recovering Refrigerant from System

### 1 DISCONNECT POWER

Disconnect all power to the existing outdoor unit at the disconnect switch or main fuse box/breaker panel.

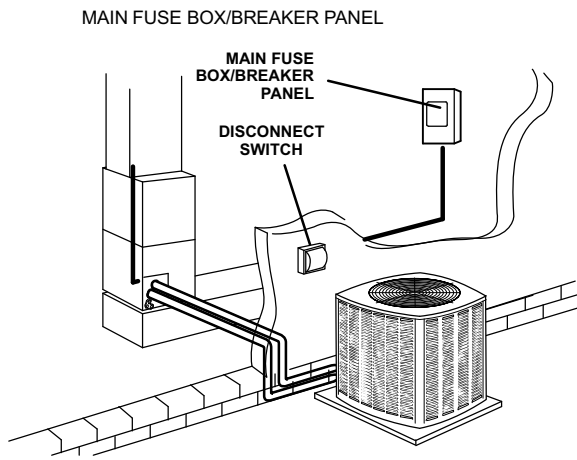

### 2 CONNECT MANIFOLD GAUGE SET

Connect a gauge set, clean recovery cylinder and a recovery machine to the service ports of the existing unit. Use the instructions provided with the recovery machine to make the connections.

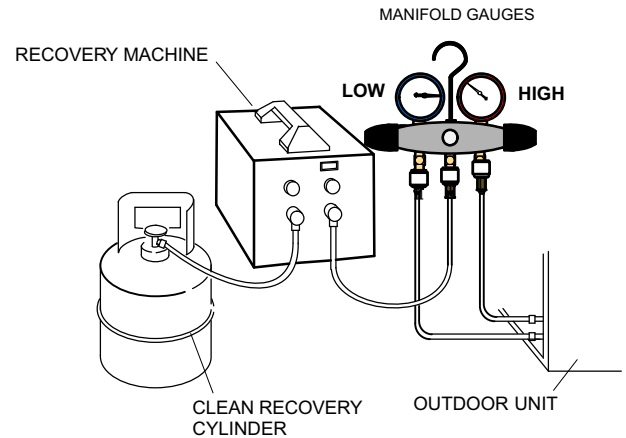

### 3 RECOVERING REFRIGERANT

Remove existing HCFC-22 refrigerant using one of the following procedures:

**IMPORTANT** — Some system configurations may contain higher than normal refrigerant charge due to either large internal coil volumes, and/or long line sets.

#### METHOD 1:

Use this method if the existing outdoor unit is not equipped with shut-off valves, or if the unit is not operational and you plan to use the existing HCFC-22 to flush the system.

Remove all HCFC-22 refrigerant from the existing system. Check gauges after shutdown to confirm that the entire system is completely void of refrigerant.

#### METHOD 2:

Use this method if the existing outdoor unit is equipped with manual shut-off valves, and you plan to use new HCFC-22 refrigerant to flush the system.

The following devices could prevent full system charge recovery into the outdoor unit:

- Outdoor unit's high or low-pressure switches (if applicable) when tripped can cycle the compressor **OFF**.
- Compressor can stop pumping due to tripped internal pressure relief valve.
- Compressor has internal vacuum protection that is designed to unload the scrolls (compressor stops pumping) when the pressure ratio meets a certain value or when the suction pressure is as high as 20 psig. (Compressor suction pressures should never be allowed to go into a vacuum. Prolonged operation at low suction pressures will result in overheating of the scrolls and permanent damage to the scroll tips, drive bearings and internal seals.)

Once the compressor can not pump down to a lower pressure due to one of the above system conditions, shut off the vapor valve. Turn OFF the main power to unit and use a recovery machine to recover any refrigerant left in the indoor coil and line set.

Perform the following task:

- A Start the existing HCFC-22 system in the cooling mode and close the liquid line valve.
- B Use the compressor to pump as much of the existing HCFC-22 refrigerant into the outdoor unit until the outdoor system is full. Turn the outdoor unit main power OFF and use a recovery machine to remove the remaining refrigerant from the system.

**NOTE** — It may be necessary to bypass the low pressure switches (if equipped) to ensure complete refrigerant evacuation.

- C When the low side system pressures reach 0 psig, close the vapor line valve.
- D Check gauges after shutdown to confirm that the valves are not allowing refrigerant to flow back into the low side of the system.

Figure 3. Refrigerant Recovery

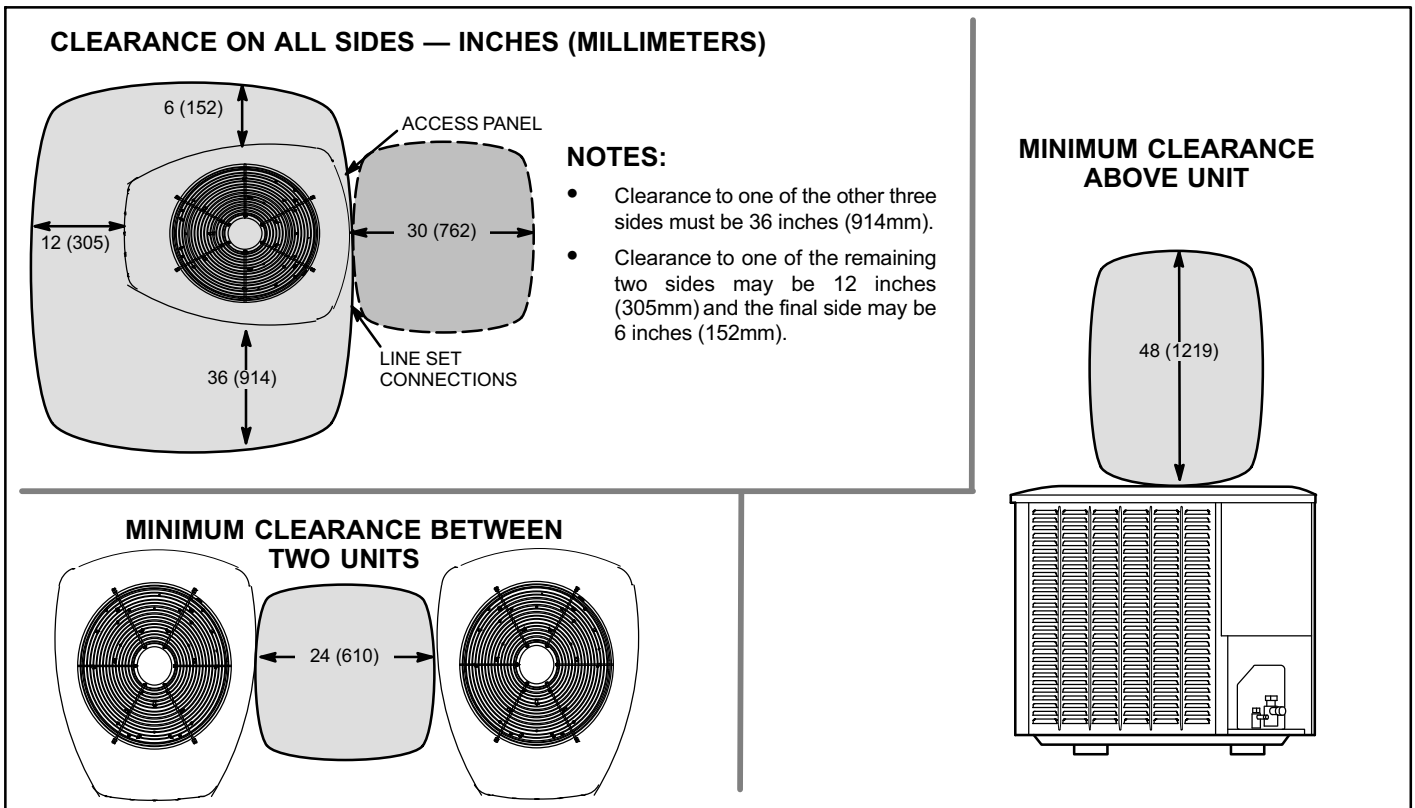

Figure 4. Installation Clearances

### Unit Placement

## ⚠ CAUTION

In order to avoid injury, take proper precaution when lifting heavy objects.

See *Unit Dimensions* on page 3 for sizing mounting slab, platforms or supports. Refer to figure 4 for mandatory installation clearance requirements.

### POSITIONING CONSIDERATIONS

Consider the following when positioning the unit:

- Some localities are adopting sound ordinances based on the unit's sound level registered from the adjacent property, not from the installation property. Install the unit as far as possible from the property line.
- When possible, do not install the unit directly outside a window. Glass has a very high level of sound transmission. For proper placement of unit in relation to a window see the provided illustration in figure 5, detail A.

### PLACING UNIT ON SLAB

When installing unit at grade level, the top of the slab should be high enough above grade so that water from higher ground will not collect around the unit. The slab should have a slope tolerance as described in figure 5, detail B.

*NOTE — If necessary for stability, anchor unit to slab as described in figure 5, detail D.*

### ELEVATING THE UNIT

Units are outfitted with elongated support feet as illustrated in figure 5, detail C.

If additional elevation is necessary, raise the unit by extending the height of the unit support feet. This may be achieved by using a 2 inch (50.8mm) Schedule 40 female threaded adapter.

The specified coupling will fit snugly into the recessed portion of the feet. Use additional 2 inch (50.8mm) Schedule 40 male threaded adaptors which can be threaded into the female threaded adaptors to make additional adjustments to the level of the unit.

*NOTE — Keep the height of extenders short enough to ensure a sturdy installation. If it is necessary to extend further, consider a different type of field-fabricated framework that is sturdy enough for greater heights.*

### DETAIL A— Outside Unit Placement

Install unit away from windows.

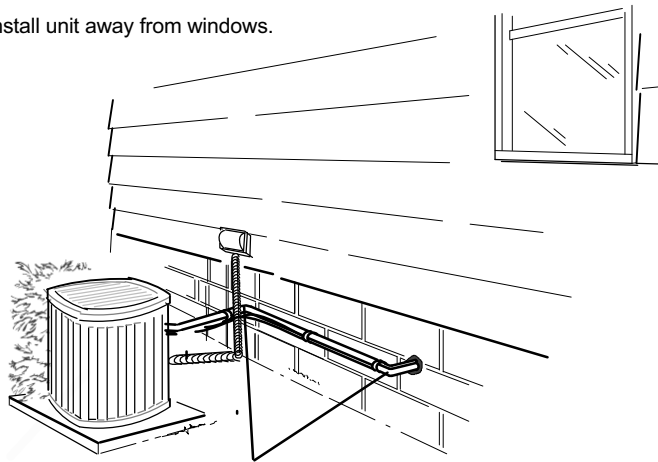

TWO 90° ELBOWS INSTALLED IN LINE SET WILL REDUCE LINE SET VIBRATION.

### DETAIL B— Slab Mounting at Ground Level

Install unit level or, if on a slope, maintain slope tolerance of two (2) degrees (or two inches per five feet [50 mm per 1.5 m]) away from building structure.

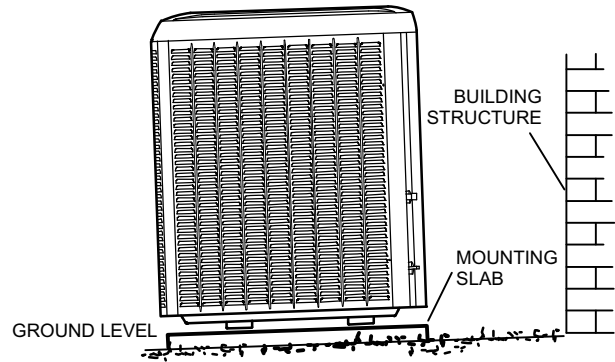

### DETAIL C— Elevated Slab Mounting using Feet Extenders

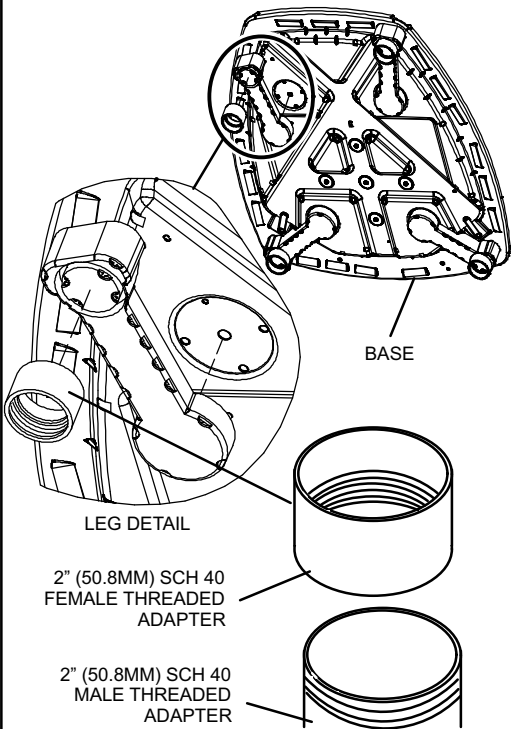

Use additional 2" SCH 40 male threaded adapters which can be threaded into the female threaded adapters to make additional adjustments to the level of the unit.

### STABILIZING UNIT ON UNEVEN SURFACES

#### DETAIL D— Slab Side Mounting

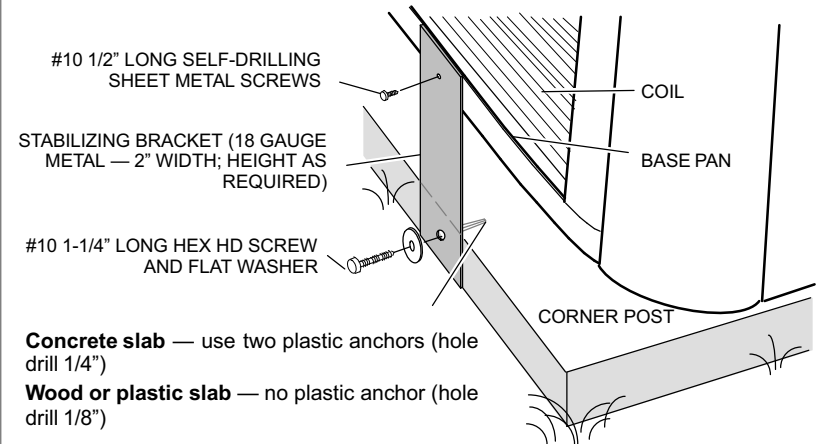

**Concrete slab** — use two plastic anchors (hole drill 1/4")

**Wood or plastic slab** — no plastic anchor (hole drill 1/8")

#### DETAIL E— Deck Top Mounting

Stabilizing bracket (18 gauge metal — 2" (50.8mm) width; height as required); bend to form right angle as exemplified below.

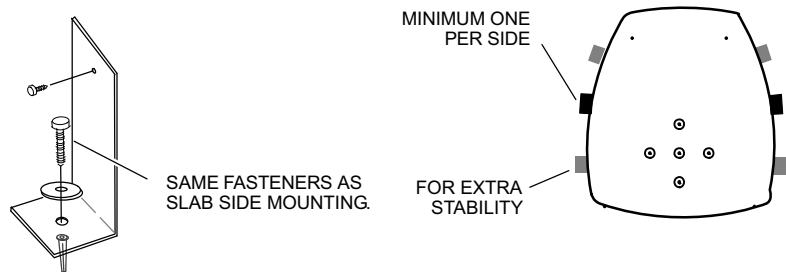

One bracket per side (minimum). For extra stability, two brackets per side, two inches (51mm) from each corner.

**IMPORTANT** — To help stabilize an outdoor unit, some installations may require strapping the unit to the pad using brackets and anchors commonly available in the marketplace.

Figure 5. Placement, Slab Mounting and Stabilizing Unit

## STABILIZING UNIT ON UNEVEN SURFACES

### **IMPORTANT**

#### Unit Stabilizer Bracket Use (field-provided):

Always use stabilizers when unit is raised above the factory height. (Elevated units could become unstable in gusty wind conditions).

Stabilizers may be used on factory height units when mounted on unstable an uneven surface.

With unit positioned at installation site, perform the following:

1. Remove two side louvered panels to expose the unit base.
2. Install the brackets as illustrated in figure 5, detail D or E using conventional practices.
3. Replace the panels after installation is complete.

## ROOF MOUNTING

Install the unit a minimum of 6 inches (152 mm) above the roof surface to avoid ice build-up around the unit. Locate the unit above a load bearing wall or area of the roof that can adequately support the unit. Consult local codes for rooftop applications.

If unit coil cannot be mounted away from prevailing winter winds, a wind barrier should be constructed. Size barrier at least the same height and width as outdoor unit. Mount barrier 24 inches (610 mm) from the sides of the unit in the direction of prevailing winds.

## NOTICE

### Roof Damage!

This system contains both refrigerant and oil. Some rubber roofing material may absorb oil and cause the rubber to swell when it comes into contact with oil. The rubber will then bubble and could cause leaks. Protect the roof surface to avoid exposure to refrigerant and oil during service and installation. Failure to follow this notice could result in damage to roof surface.

### Removing and Installing Panels

### **IMPORTANT**

Do not allow panels to hang on unit by top tab. Tab is for alignment and not designed to support weight of panel.

### **IMPORTANT**

To help stabilize an outdoor unit, some installations may require strapping the unit to the pad using brackets and anchors commonly available in the marketplace.

### **WARNING**

To prevent personal injury, or damage to panels, unit or structure, be sure to observe the following:

While installing or servicing this unit, carefully stow all removed panels out of the way, so that the panels will not cause injury to personnel, nor cause damage to objects or structures nearby, nor will the panels be subjected to damage (e.g., being bent or scratched).

While handling or stowing the panels, consider any weather conditions, especially windy conditions, that may cause panels to be blown around and battered.

## LOUVERED PANEL REMOVAL

Remove the louvered panels as follows:

1. Remove two screws, allowing the panel to swing open slightly.
2. Hold the panel firmly throughout this procedure. Rotate bottom corner of panel away from hinged corner post until lower three tabs clear the slots as illustrated in **detail B**.
3. Move panel down until lip of upper tab clears the top slot in corner post as illustrated in **detail A**.

## LOUVERED PANEL INSTALLATION

Position the panel almost parallel with the unit as illustrated in **detail D** with the screw side as close to the unit as possible.

Then, in a continuous motion:

1. Slightly rotate and guide the lip of top tab inward as illustrated in **detail A** and **C**; then upward into the top slot of the hinge corner post.
2. Rotate panel to vertical to fully engage all tabs.
3. Holding the panel's hinged side firmly in place, close the right-hand side of the panel, aligning the screw holes.
4. When panel is correctly positioned and aligned, insert the screws and tighten.

### Detail C

MAINTAIN MINIMUM PANEL ANGLE (AS CLOSE TO PARALLEL WITH THE UNIT AS POSSIBLE) WHILE INSTALLING PANEL.

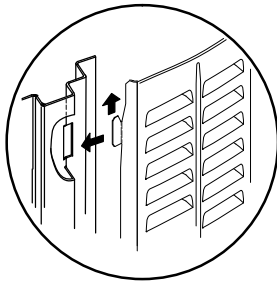

**IMPORTANT!** DO NOT ALLOW PANELS TO HANG ON UNIT BY TOP TAB. TAB IS FOR ALIGNMENT AND NOT DESIGNED TO SUPPORT WEIGHT OF PANEL.

PANEL SHOWN SLIGHTLY ROTATED TO ALLOW TOP TAB TO EXIT (OR ENTER) TOP SLOT FOR REMOVING (OR INSTALLING) PANEL.

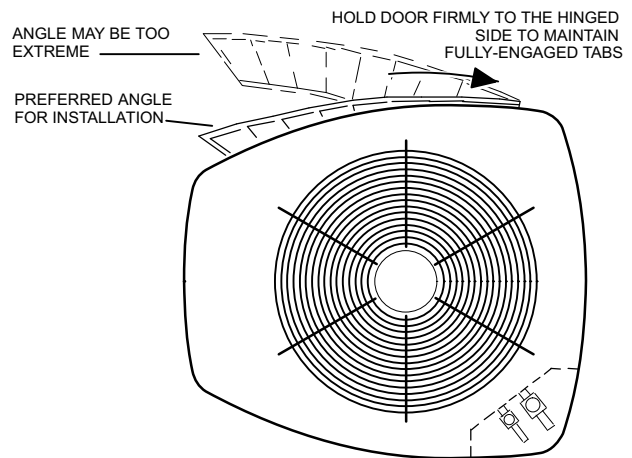
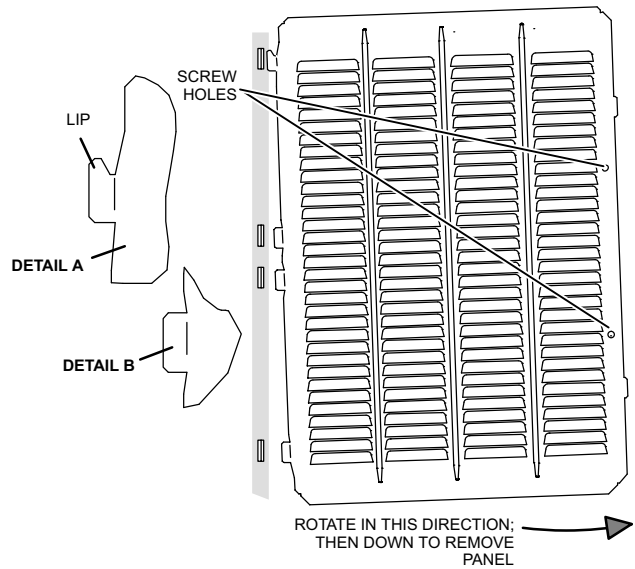

Figure 6. Removing and Installing Panels

## New or Replacement Line Set

### REFRIGERANT LINE SET

This section provides information on installation or replacement of existing line set. If new or replacement line set is not being installed then proceed to *Brazing Connections* on page 16.

## IMPORTANT

Lennox highly recommends changing line set when converting the existing system from HCFC-22 to HFC-410A. If that is not possible and the line set is the proper size as reference in table 2, use the procedure outlined under *Flushing the System* on page 13.

If refrigerant lines are routed through a wall, then seal and isolate the opening so vibration is not transmitted to the building. Pay close attention to line set isolation during installation of any HVAC system. When properly isolated from building structures (walls, ceilings, floors), the refrigerant lines will not create unnecessary vibration and subsequent sounds. See figure 7 for recommended installation practices. Also, consider the following when placing and installing a high-efficiency outdoor unit.

Liquid lines that meter the refrigerant, such as RFC1 liquid lines, must not be used in this application. Existing line set of proper size as listed in table 2 may be reused. If system was previously charged with HCFC-22 refrigerant, then existing line set must be flushed (see *Flushing the System* on page 19).

Field refrigerant piping consists of liquid and vapor lines from the outdoor unit to the indoor unit coil (braze connections). Use Lennox L15 (sweat, non-flare) series line set, or field-fabricated refrigerant line sizes as listed in table 2.

**Table 2. Refrigerant Line Set — Inches (mm)**

XC13	Valve Field Connections		Recommended Line Set		
	Liquid Line	Suction Line	Liquid Line	Suction Line	L15 Line Sets
-018 -024 -030	3/8 in. (10 mm)	3/4 in. (19 mm)	3/8 in. (10 mm)	3/4 in. (19 mm)	L15-41 15 ft. - 50 ft. (4.6 m - 15 m)
-036 -042 -048	3/8 in. (10 mm)	7/8 in. (22 mm)	3/8 in. (10 mm)	7/8 in. (22 mm)	L15-65 15 ft. - 50 ft. (4.6 m - 15 m)
-060	3/8 in. (10 mm)	1-1/8 in. (29 mm)	3/8 in. (10 mm)	1-1/8 in. (29 mm)	Field Fabricated

*NOTE* — When installing refrigerant lines longer than 50 feet, see the *Lennox Refrigerant Piping Design and Fabrication Guidelines, CORP. 9351-L9*, or contact *Lennox Technical Support Product Applications* for assistance.

To obtain the correct information from Lennox, be sure to communicate the following information:

- Model (XC13) and size of unit (e.g. -036).
- Line set diameters for the unit being installed as listed in table 2 and total length of installation.
- Number of elbows vertical rise or drop in the piping.

The compressor is charged with sufficient Polyol ester oil for line set lengths up to 50 feet. Recommend adding oil to system based on the amount of refrigerant charge in the system. No need to add oil in system with 20 pounds of refrigerant or less. For systems over 20 pounds - add one ounce of every five pounds of refrigerant.

Recommended topping-off POE oils are Mobil EAL ARCTIC 22 CC or ICI EMKARATE™ RL32CF.

## WARNING

Polyol Ester (POE) oils used with HFC-410A refrigerant absorb moisture very quickly. It is very important that the refrigerant system be kept closed as much as possible. DO NOT remove line set caps or service valve stub caps until you are ready to make connections.

## IMPORTANT

Mineral oils are not compatible with HFC-410A. If oil must be added, it must be a Polyol Ester oil.

**Line Set Isolation** — The following illustrations are examples of proper refrigerant line set isolation:

### REFRIGERANT LINE SET — TRANSITION FROM VERTICAL TO HORIZONTAL

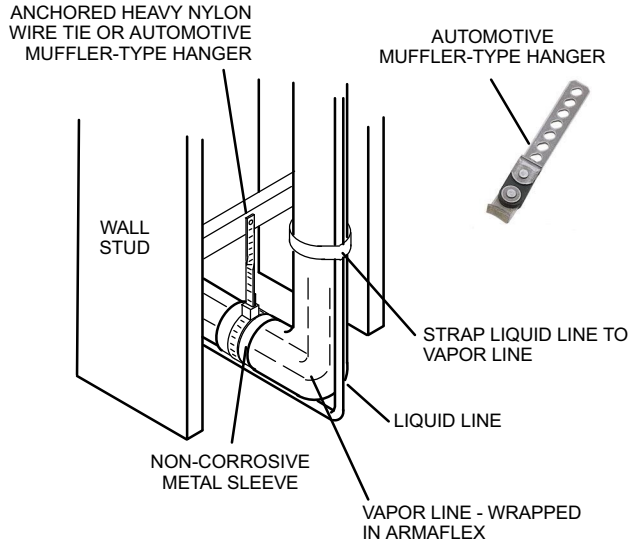

### REFRIGERANT LINE SET — INSTALLING VERTICAL RUNS (NEW CONSTRUCTION SHOWN)

**NOTE** — Insulate liquid line when it is routed through areas where the surrounding ambient temperature could become higher than the temperature of the liquid line or when pressure drop is equal to or greater than 20 psig.

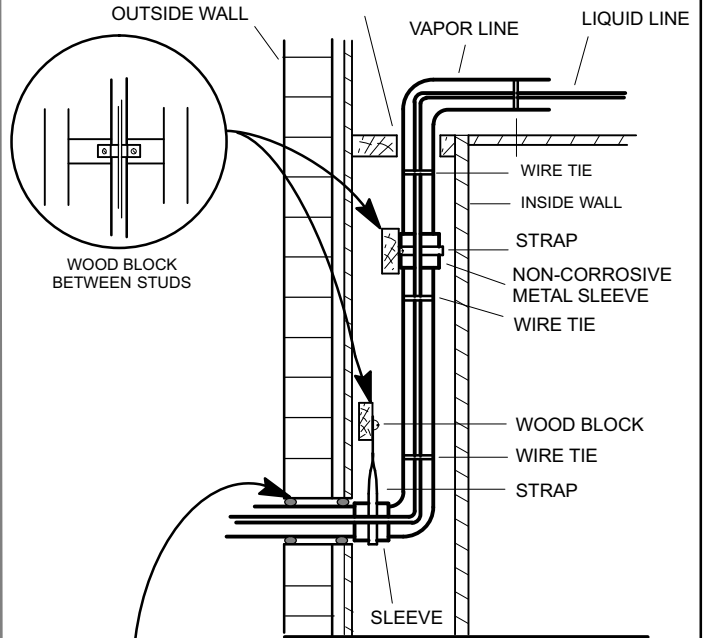

### REFRIGERANT LINE SET — INSTALLING HORIZONTAL RUNS

To hang line set from joist or rafter, use either metal strapping material or anchored heavy nylon wire ties.

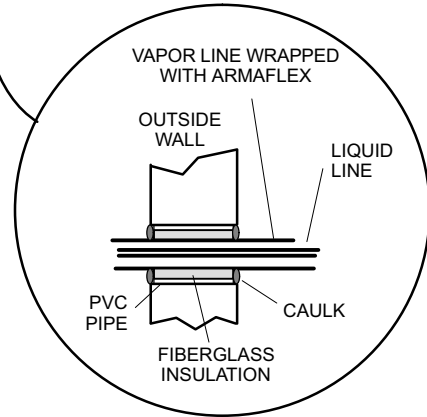
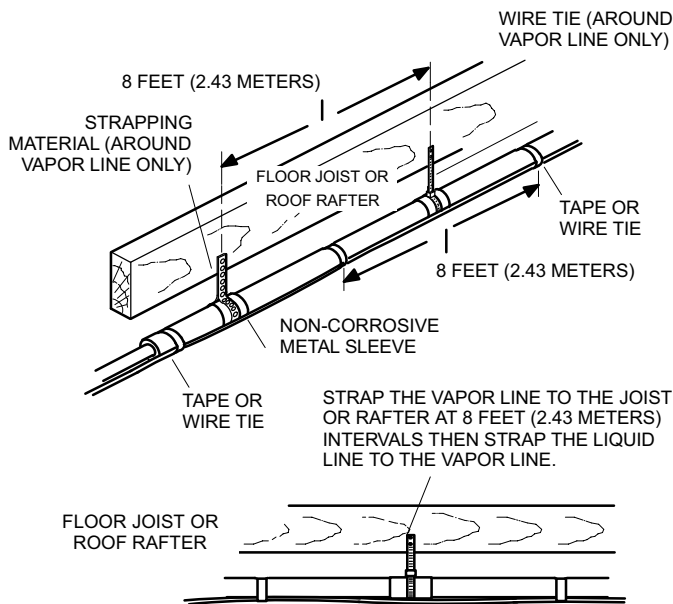

**NOTE** — Similar installation practices should be used if line set is to be installed on exterior of outside wall.

**Figure 7. Line Set Installation**

## Brazing Connections

Use the procedures outline in figures 8 and 9 for brazing line set connections to service valves.

### WARNING



Danger of fire. Bleeding the refrigerant charge from only the high side may result in pressurization of the low side shell and suction tubing. Application of a brazing torch to a pressurized system may result in ignition of the refrigerant and oil mixture - Check the high and low pressures before applying heat.

### WARNING



When using a high pressure gas such as dry nitrogen to pressurize a refrigeration or air conditioning system, use a regulator that can control the pressure down to 1 or 2 psig (6.9 to 13.8 kPa).

### CAUTION

Brazing alloys and flux contain materials which are hazardous to your health.

Avoid breathing vapors or fumes from brazing operations. Perform operations only in well-ventilated areas.

Wear gloves and protective goggles or face shield to protect against burns.

Wash hands with soap and water after handling brazing alloys and flux.

### IMPORTANT

Connect gauge set low pressure side to vapor line service valve and repeat procedure starting at paragraph 4 for brazing the liquid line to service port valve.

### IMPORTANT

Allow braze joint to cool before removing the wet rag from the service valve. Temperatures above 250°F can damage valve seals.

### IMPORTANT

Use silver alloy brazing rods with 5% minimum silver alloy for copper-to-copper brazing. Use 45% minimum alloy for copper-to-brass and copper-to-steel brazing.

### WARNING



Fire, Explosion and Personal Safety Hazard.

Failure to follow this warning could result in damage, personal injury or death.

Never use oxygen to pressurize or purge refrigeration lines. Oxygen, when exposed to a spark or open flame, can cause fire and/or an explosion, that could result in property damage, personal injury or death.



# 1 CUT AND DEBUR

Cut ends of the refrigerant lines square (free from nicks or dents) and debur the ends. The pipe must remain round. Do not crimp end of the line.

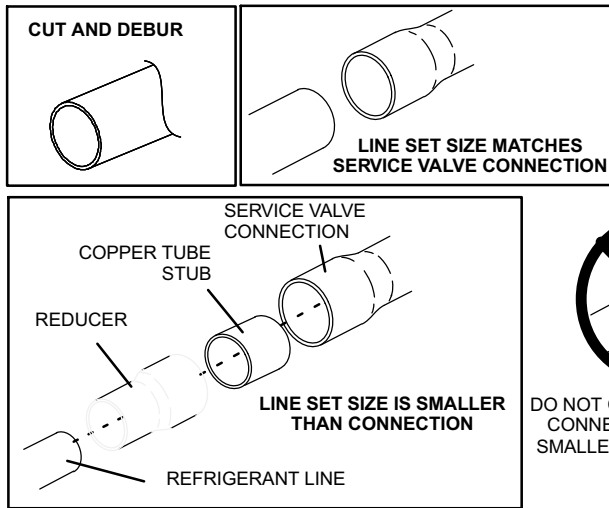

# 2 CAP AND CORE REMOVAL

Remove service cap and core from both the suction / vapor and liquid line service ports.

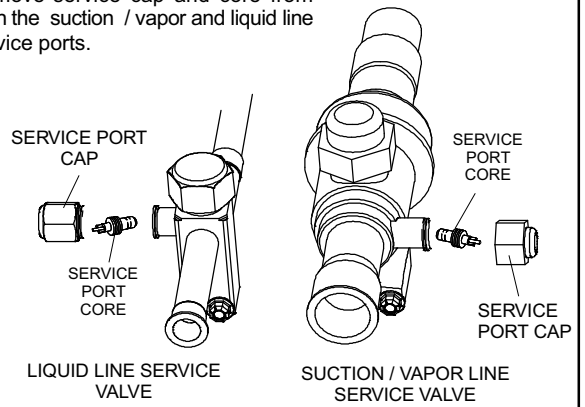

# 3 ATTACH THE MANIFOLD GAUGE SET FOR BRAZING LIQUID AND SUCTION / VAPOR LINE SERVICE VALVES

Flow regulated nitrogen (at 1 to 2 psig) through the low-side refrigeration gauge set into the liquid line service port valve, and out of the suction / vapor line service port valve.

- A Connect gauge set low pressure side to liquid line service valve (service port).
- B Connect gauge set center port to bottle of nitrogen with regulator.
- C Remove core from valve in suction / vapor line service port to allow nitrogen to escape.

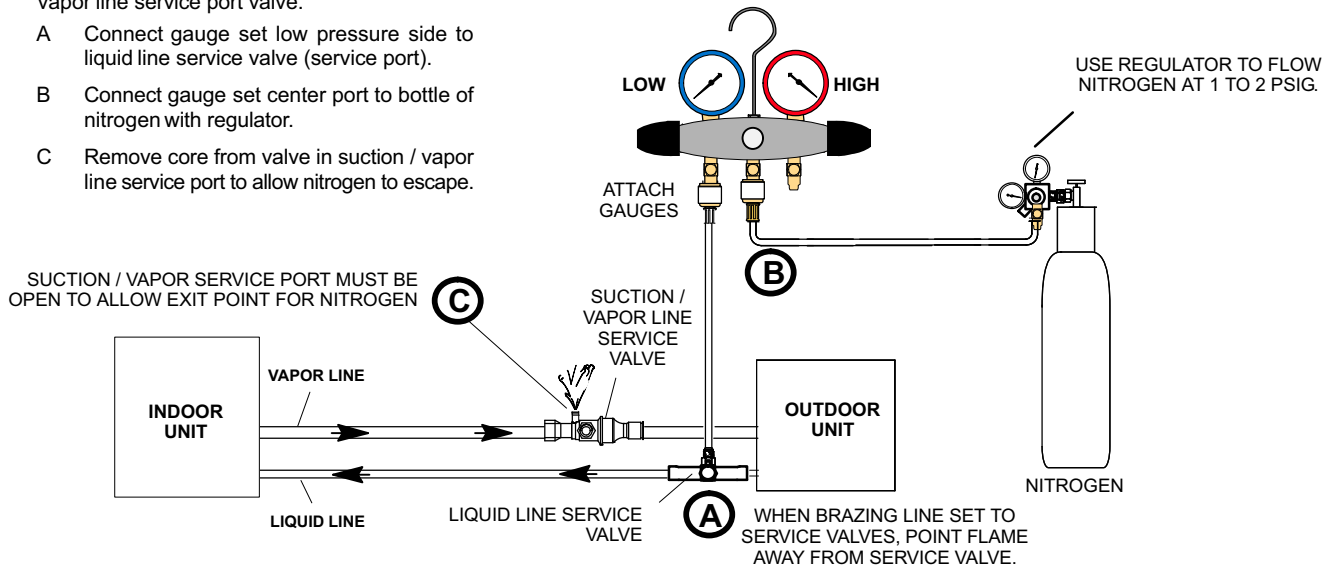

Figure 8. Brazing Procedures

## 4 WRAP SERVICE VALVES

To help protect service valve seals during brazing, wrap water saturated cloths around service valve bodies and copper tube stubs. Use additional water saturated cloths underneath the valve body to protect the base paint.

## 5 FLOW NITROGEN

Flow regulated nitrogen (at 1 to 2 psig) through the refrigeration gauge set into the valve stem port connection on the liquid service valve and out of the suction / vapor valve stem port. See steps **3A**, **3B** and **3C** on manifold gauge set connections

## 6 BRAZE LINE SET

Wrap both service valves with water saturated cloths as illustrated here and as mentioned in step 4, before brazing to line set. Water saturated cloths must remain water saturated throughout the brazing and cool-down process.

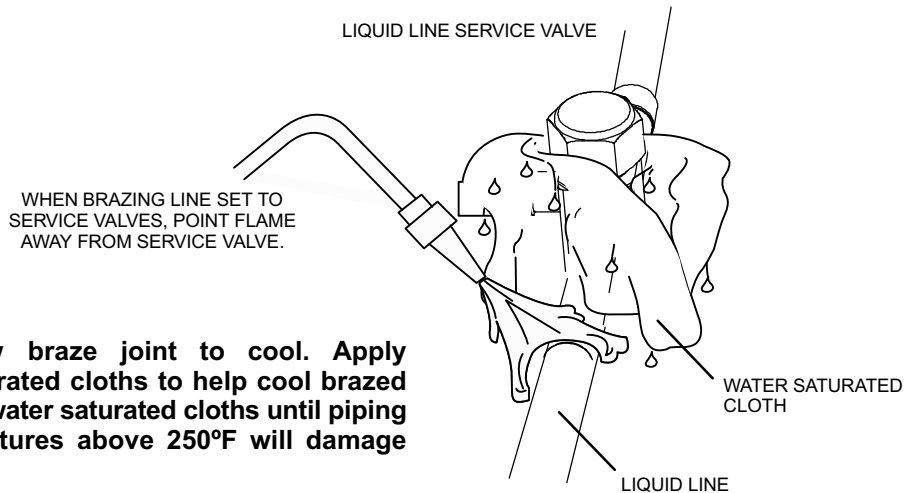

**IMPORTANT — Allow braze joint to cool. Apply additional water saturated cloths to help cool brazed joint. Do not remove water saturated cloths until piping has cooled. Temperatures above 250°F will damage valve seals.**

### WARNING

- 1. FIRE, PERSONAL INJURY, OR PROPERTY DAMAGE** will result if you do not wrap a water saturated cloth around both liquid and suction line service valve bodies and copper tube stub while brazing in the line set! The braze, when complete, must be quenched with water to absorb any residual heat.
- 2. Do not open service valves until refrigerant lines and indoor coil have been leak-tested and evacuated. Refer to procedures provided in this supplement.**

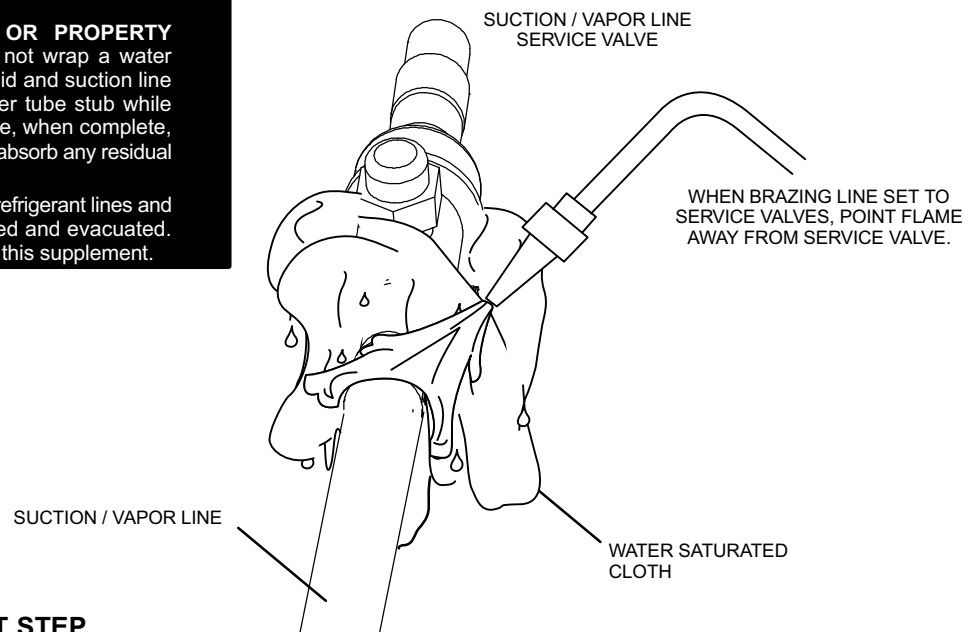

## 7 PREPARATION FOR NEXT STEP

After all connections have been brazed, disconnect manifold gauge set from service ports. Apply additional water saturated cloths to both services valves to cool piping. Once piping is cool, remove all water saturated cloths. Refer to the unit installation instructions for the next step in preparing the unit.

**Figure 9. Brazing Procedures (continued)**

## Flushing Line Set and Indoor Coil

### 1A TYPICAL EXISTING FIXED ORIFICE REMOVAL PROCEDURE (UNCASED OR COIL SHOWN)

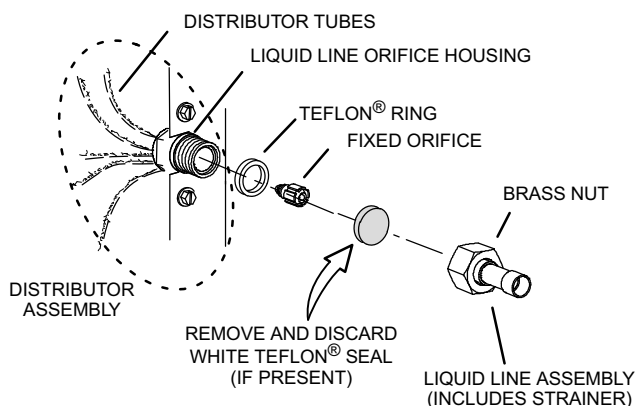

- A On fully cased coils, remove the coil access and plumbing panels.
- B Remove any shipping clamps holding the liquid line and distributor assembly.
- C Using two wrenches, disconnect liquid line from liquid line orifice housing. Take care not to twist or damage distributor tubes during this process.
- D Remove and discard fixed orifice, valve stem assembly if present and Teflon® washer as illustrated above.
- E Use a field-provided fitting to temporary reconnect the liquid line to the indoor unit's liquid line orifice housing.

### 1B TYPICAL EXISTING EXPANSION VALVE REMOVAL PROCEDURE (UNCASED COIL SHOWN)

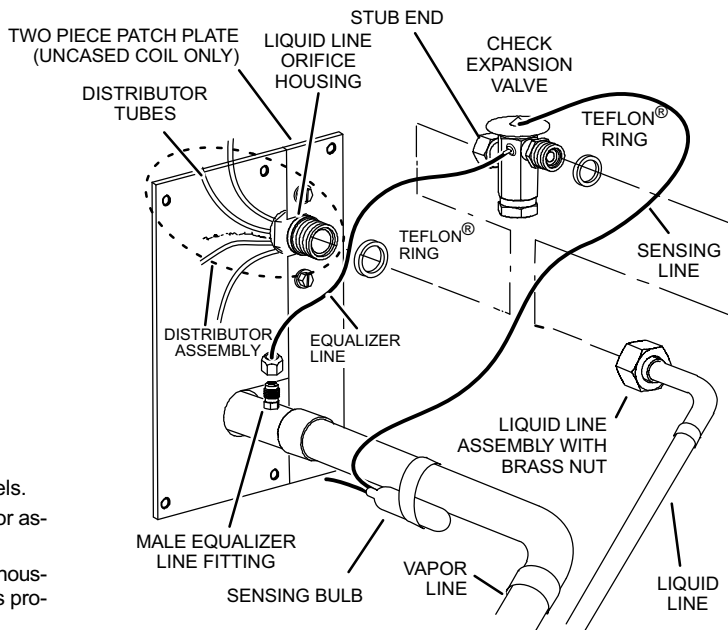

- A On fully cased coils, remove the coil access and plumbing panels.
- B Remove any shipping clamps holding the liquid line and distributor assembly.
- C Disconnect the equalizer line from the check expansion valve equalizer line fitting on the vapor line.
- D Remove the vapor line sensing bulb.
- E Disconnect the liquid line from the check expansion valve at the liquid line assembly.
- F Disconnect the check expansion valve from the liquid line orifice housing. Take care not to twist or damage distributor tubes during this process.
- G Remove and discard check expansion valve and the two Teflon® rings.
- H Use a field-provided fitting to temporary reconnect the liquid line to the indoor unit's liquid line orifice housing.

### 2 CONNECT GAUGES AND EQUIPMENT FOR FLUSHING PROCEDURE

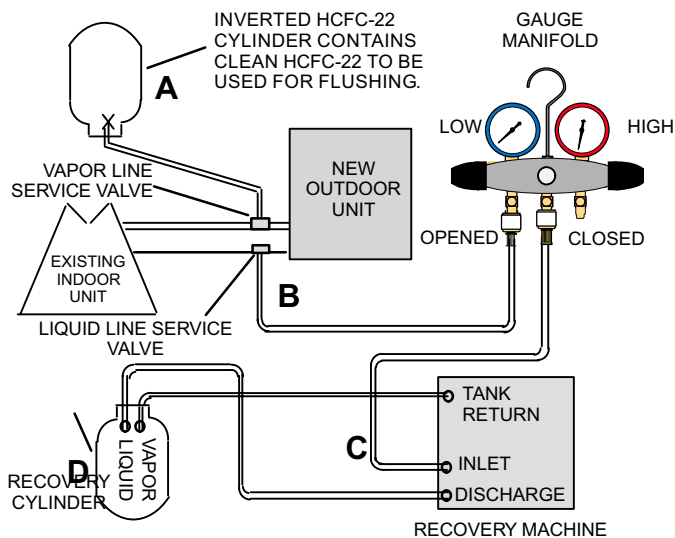

- A Inverted HCFC-22 cylinder with clean refrigerant to the vapor service valve.
- B HCFC-22 gauge set (low side) to the liquid line valve.
- C HCFC-22 gauge set center port to inlet on the recovery machine with an empty recovery tank to the gauge set.
- D Connect recovery tank to recovery machines per machine instructions.

### 3 FLUSHING LINE SET

The line set and indoor unit coil must be flushed with at least the same amount of clean refrigerant that previously charged the system. Check the charge in the flushing cylinder before proceeding.

- A Set the recovery machine for liquid recovery and start the recovery machine. Open the gauge set valves to allow the recovery machine to pull a vacuum on the existing system line set and indoor unit coil.
- B Invert the cylinder of clean HCFC-22 and open its valve to allow liquid refrigerant to flow into the system through the vapor line valve. Allow the refrigerant to pass from the cylinder and through the line set and the indoor unit coil before it enters the recovery machine.
- C After all of the liquid refrigerant has been recovered, switch the recovery machine to vapor recovery so that all of the HCFC-22 vapor is recovered. Allow the recovery machine to pull down to 0 on the system.
- D Close the valve on the inverted HCFC-22 drum and the gauge set valves. Pump the remaining refrigerant out of the recovery machine and turn the machine off.

Figure 10. Installing Indoor Expansion Valve

## Installing Indoor Metering Device

This outdoor unit is designed for use in systems that use either fixed orifice or expansion valve metering devices at the indoor coil.

- If using a fixed orifice metering device, use the one provided with the outdoor unit. The metering device is located in the installation instruction bag. For installing the orifice, reverse the procedure outlined in figure 10, 1A.

- See the *Lennox XC13 Engineering Handbook* for approved expansion valve kit match-ups. The expansion valve unit can be installed internal or external to the indoor coil. In applications where an uncased coil is being installed in a field-provided plenum, install the expansion valve in a manner that will provide access for field servicing of the expansion valve. Refer to below illustration for reference during installation of expansion valve unit.

### INDOOR EXPANSION VALVE INSTALLATION

**(Uncased Coil Shown)**

Labels in diagram: TWO PIECE PATCH PLATE (UNCASED COIL ONLY), LIQUID LINE ORIFICE HOUSING, STUB END, EXPANSION VALVE, TEFLON® RING, SENSING LINE, DISTRIBUTOR TUBES, DISTRIBUTOR ASSEMBLY, EQUALIZER LINE, LIQUID LINE ASSEMBLY WITH BRASS NUT, VAPOR LINE, LIQUID LINE, MALE EQUALIZER LINE FITTING (SEE EQUALIZER LINE INSTALLATION FOR FURTHER DETAILS).

Sensing bulb insulation is required if mounted external to the coil casing. sensing bulb installation for bulb positioning.

- Remove the field-provided fitting that temporary reconnected the liquid line to the indoor unit's distributor assembly.
- Install one of the provided Teflon® rings around the stubbed end of the expansion valve and lightly lubricate the connector threads and expose surface of the Teflon® ring with refrigerant oil.
- Attach the stubbed end of the expansion valve to the liquid line orifice housing. Finger tighten and use an appropriately sized wrench to turn an additional 1/2 turn clockwise as illustrated in the figure above, or 20 ft-lb.
- Place the remaining Teflon® washer around the other end of the expansion valve. Lightly lubricate connector threads and expose surface of the Teflon® ring with refrigerant oil.
- Attach the liquid line assembly to the expansion valve. Finger tighten and use an appropriately sized wrench to turn an additional 1/2 turn clockwise as illustrated in the figure above or 20 ft-lb.

---

### EQUALIZER LINE INSTALLATION

- Remove and discard either the flare seal cap or flare nut with copper flare seal bonnet from the equalizer line port on the vapor line as illustrated in the figure to the right.
- Remove and discard either the flare seal cap or flare nut with copper flare seal bonnet from the equalizer line port on the vapor line as illustrated in the figure to the right.

Labels: FLARE SEAL CAP, FLARE NUT, COPPER FLARE SEAL BONNET, MALE BRASS EQUALIZER LINE FITTING, VAPOR LINE.

### SENSING BULB INSTALLATION

- Attach the vapor line sensing bulb in the proper orientation as illustrated to the right using the clamp and screws provided.

**NOTE** — Confirm proper thermal contact between vapor line and expansion bulb before insulating the sensing bulb once installed.

- Connect the equalizer line from the expansion valve to the equalizer vapor port on the vapor line. Finger tighten the flare nut plus 1/8 turn (7 ft-lbs) as illustrated below.

Labels: VAPOR LINE, BULB.

ON LINES SMALLER THAN 7/8", MOUNT SENSING BULB AT EITHER THE 3 OR 9 O'CLOCK POSITION.

Labels: VAPOR LINE, BULB.

ON 7/8" AND LARGER LINES, MOUNT SENSING BULB AT EITHER THE 4 OR 8 O'CLOCK POSITION. NEVER MOUNT ON BOTTOM OF LINE.

**NOTE** — NEVER MOUNT ON BOTTOM OF LINE.

Figure 11. Installing Indoor Expansion Valve

## ⚠ IMPORTANT

The Environmental Protection Agency (EPA) prohibits the intentional venting of HFC refrigerants during maintenance, service, repair and disposal of appliance. Approved methods of recovery, recycling or reclaiming must be followed.

## ⚠ IMPORTANT

If this unit is being matched with an approved line set or indoor unit coil which was previously charged with mineral oil, or if it is being matched with a coil which was manufactured before January of 1999, the coil and line set must be flushed prior to installation. Take care to empty all existing traps. Polyol ester (POE) oils are used in Lennox units charged with HFC-410A refrigerant. Residual mineral oil can act as an insulator, preventing proper heat transfer. It can also clog the expansion device, and reduce the system performance and capacity. Failure to properly flush the system per the instructions below will void the warranty.

## Leak Test Line Set and Indoor Coil

## ⚠ WARNING



When using a high pressure gas such as dry nitrogen to pressurize a refrigeration or air conditioning system, use a regulator that can control the pressure down to 1 or 2 psig (6.9 to 13.8 kPa).

## ⚠ IMPORTANT

Leak detector must be capable of sensing HFC refrigerant.

## ⚠ WARNING

Refrigerant can be harmful if it is inhaled. Refrigerant must be used and recovered responsibly.

Failure to follow this warning may result in personal injury or death.

### 1 CONNECT GAUGE SET

- A Connect an HFC-410A manifold gauge set high pressure hose to the vapor valve service port.

**NOTE** — Normally, the high pressure hose is connected to the liquid line port. However, connecting it to the vapor port better protects the manifold gauge set from high pressure damage.

- B With both manifold valves closed, connect the cylinder of HFC-410A refrigerant to the center port of the manifold gauge set.

**NOTE** — Later in the procedure, the HFC-410A container will be replaced by the nitrogen container.

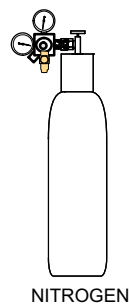

NITROGEN

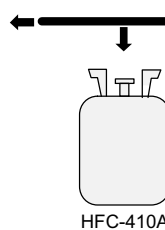

HFC-410A

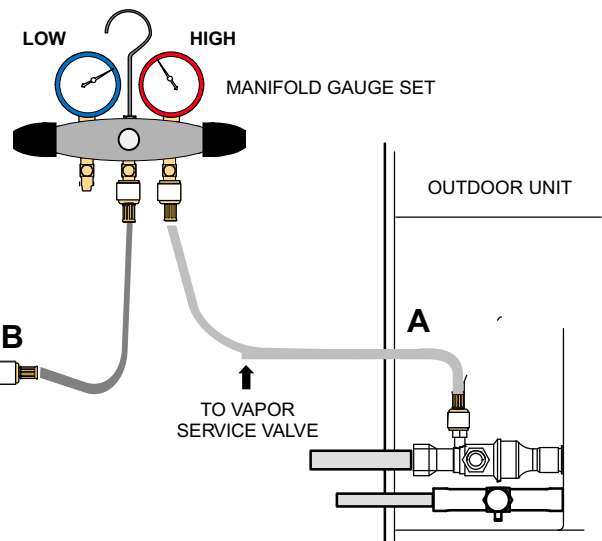

### 2 TEST FOR LEAKS

After the line set has been connected to the indoor and outdoor units, check the line set connections and indoor unit for leaks. Use the following procedure to test for leaks:

- A With both manifold valves closed, connect the cylinder of HFC-410A refrigerant to the center port of the manifold gauge set. Open the valve on the HFC-410A cylinder (vapor only).
- B Open the high pressure side of the manifold to allow HFC-410A into the line set and indoor unit. Weigh in a trace amount of HFC-410A. [A trace amount is a maximum of two ounces (57 g) refrigerant or three pounds (31 kPa) pressure]. Close the valve on the HFC-410A cylinder and the valve on the high pressure side of the manifold gauge set. Disconnect the HFC-410A cylinder.
- C Connect a cylinder of dry nitrogen with a pressure regulating valve to the center port of the manifold gauge set.
- D Adjust dry nitrogen pressure to 150 psig (1034 kPa). Open the valve on the high side of the manifold gauge set in order to pressurize the line set and the indoor unit.
- E After a few minutes, open one of the service valve ports and verify that the refrigerant added to the system earlier is measurable with a leak detector.
- F After leak testing disconnect gauges from service ports.

Figure 12. Leak Test

## Evacuating Line Set and Indoor Coil

### 1 CONNECT GAUGE SET

**NOTE** — Remove cores from service valves (if not already done).

- A Connect low side of manifold gauge set with 1/4 SAE in-line tee to vapor line service valve
- B Connect high side of manifold gauge set to liquid line service valve
- C Connect micron gauge available connector on the 1/4 SAE in-line tee.
- D Connect the vacuum pump (with nitrogen gauge) to the center port of the manifold gauge set. The center port line will be used later for both the HFC-410A and nitrogen containers.

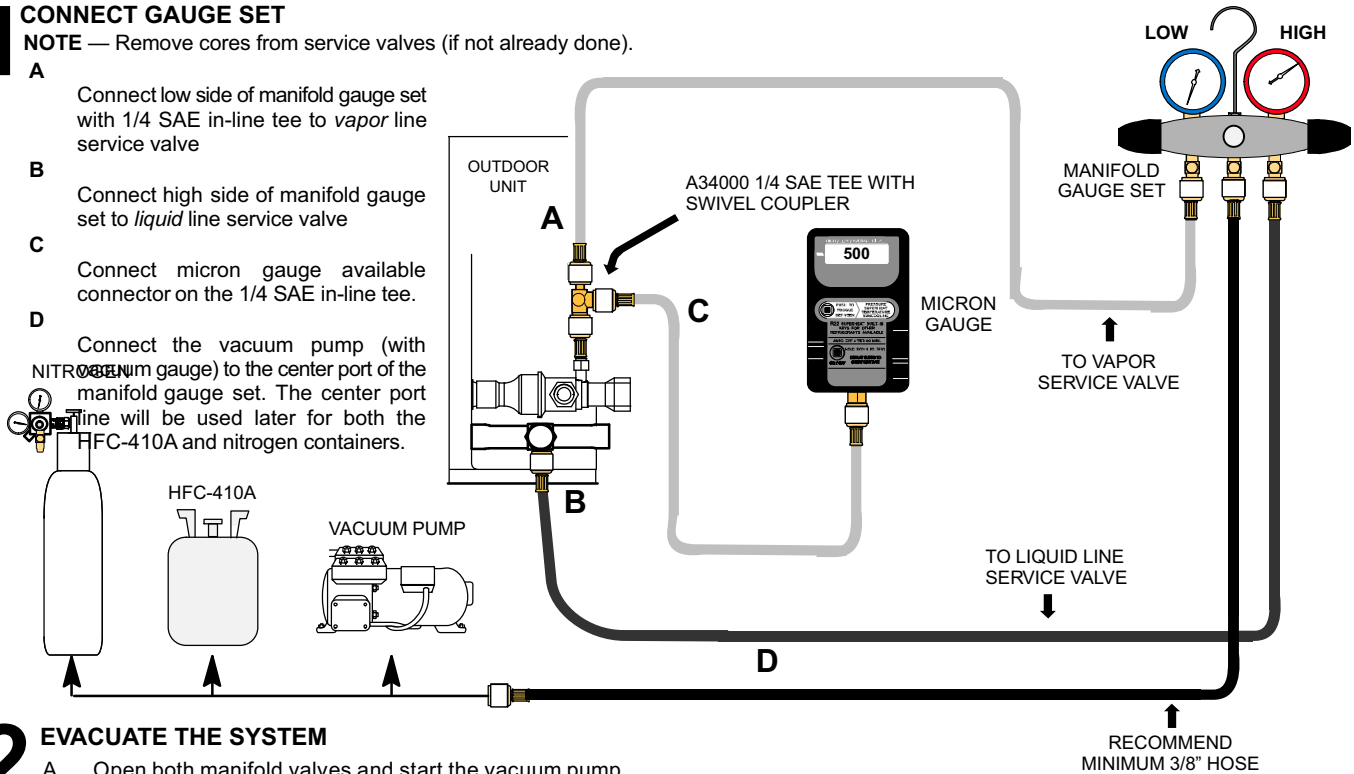

### 2 EVACUATE THE SYSTEM

- A Open both manifold valves and start the vacuum pump.
- B Evacuate the line set and indoor unit to an **absolute pressure** of 23,000 microns (29.01 inches of mercury).
 

**NOTE** — During the early stages of evacuation, it is desirable to close the manifold gauge valve at least once. A rapid rise in pressure indicates a relatively large leak. If this occurs, **repeat the leak testing procedure**.

**NOTE** — The term **absolute pressure** means the total actual pressure within a given volume or system, above the absolute zero of pressure. Absolute pressure in a vacuum is equal to atmospheric pressure minus vacuum pressure.
- C When the absolute pressure reaches 23,000 microns (29.01 inches of mercury), perform the following:
  - Close manifold gauge valves
  - Close valve on vacuum pump
  - Turn off vacuum pump
  - Disconnect manifold gauge center port hose from vacuum pump
  - Attach manifold center port hose to a dry nitrogen cylinder with pressure regulator set to 150 psig (1034 kPa) and purge the hose.
  - Open manifold gauge valves to break the vacuum in the line set and indoor unit.
  - Close manifold gauge valves.
- D Shut off the dry nitrogen cylinder and remove the manifold gauge hose from the cylinder. Open the manifold gauge valves to release the dry nitrogen from the line set and indoor unit.
- E Reconnect the manifold gauge to the vacuum pump, turn the pump on, and continue to evacuate the line set and indoor unit until the absolute pressure does not rise above 500 microns (29.9 inches of mercury) within a 20-minute period after shutting off the vacuum pump and closing the manifold gauge valves.
- F When the absolute pressure requirement above has been met, disconnect the manifold hose from the vacuum pump and connect it to an upright cylinder of HFC-410A refrigerant. Open the manifold gauge valve 1 to 2 psig in order to release the vacuum in the line set and indoor unit.
- G Perform the following:
  - Close manifold gauge valves.
  - Shut off HFC-410A cylinder.
  - Reinstall service valve cores by removing manifold hose from service valve. Quickly install cores with core tool while maintaining a positive system pressure.
  - Replace stem caps and secure finger tight, then tighten an additional one-sixth (1/6) of a turn as illustrated.

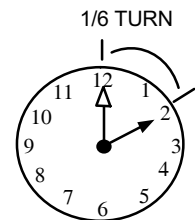

Figure 13. Evacuating System

## ⚠ IMPORTANT

Use a thermocouple or thermistor electronic vacuum gauge that is calibrated in microns. Use an instrument capable of accurately measuring down to 50 microns.

## ⚠ WARNING

Danger of Equipment Damage. Avoid deep vacuum operation. Do not use compressors to evacuate a system. Extremely low vacuums can cause internal arcing and compressor failure. Damage caused by deep vacuum operation will void warranty.

Evacuating the system of non-condensables is critical for proper operation of the unit. Non-condensables are defined as any gas that will not condense under

temperatures and pressures present during operation of an air conditioning system. Non-condensables and water suction combine with refrigerant to produce substances that corrode copper piping and compressor parts.

## Electrical

In the U.S.A., wiring must conform with current local codes and the current National Electric Code (NEC). In Canada, wiring must conform with current local codes and the current Canadian Electrical Code (CEC).

Refer to the furnace or air handler installation instructions for additional wiring application diagrams and refer to unit nameplate for minimum circuit ampacity and maximum overcurrent protection size.

### 24VAC TRANSFORMER

Use the transformer provided with the furnace or air handler for low-voltage control power (24VAC - 40 VA minimum)

## 1 SIZE CIRCUIT AND INSTALL DISCONNECT SWITCH

Refer to the unit nameplate for minimum circuit ampacity, and maximum fuse or circuit breaker (HACR per NEC). Install power wiring and properly sized disconnect switch.

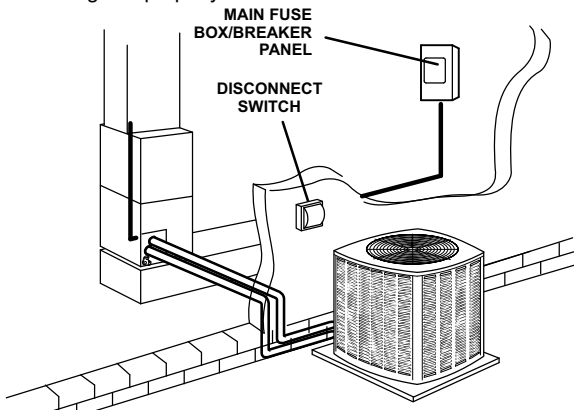

**NOTE** — Units are approved for use only with copper conductors. Ground unit at disconnect switch or to an earth ground.

## 2 INSTALL THERMOSTAT

Install room thermostat (ordered separately) on an inside wall approximately in the center of the conditioned area and 5 feet (1.5m) from the floor. It should not be installed on an outside wall or where it can be affected by sunlight or drafts.

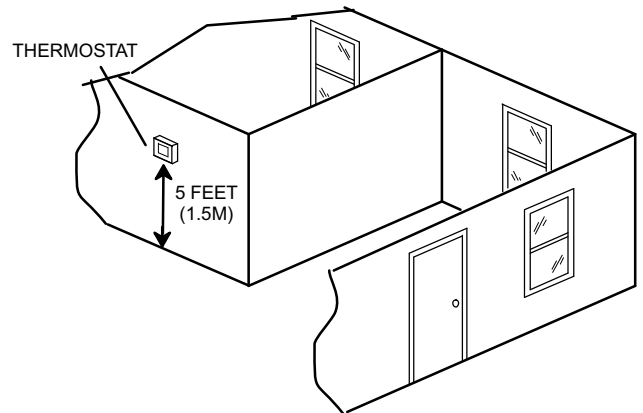

**NOTE** — 24VAC, Class II circuit connections are made in the control panel.

## 3 UNIT LOW VOLTAGE CONNECTIONS

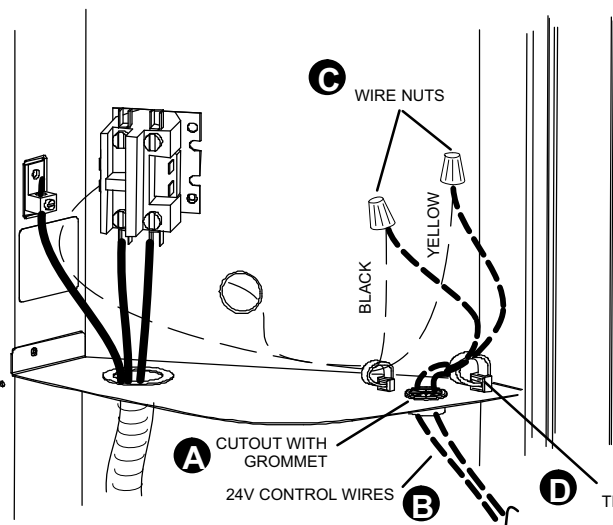

- HIGH VOLTAGE FIELD WIRING
- FACTORY WIRING
- - - LOW VOLTAGE (24V) FIELD WIRING

WIRE RUN LENGTH	AWG#	INSULATION TYPE
LESS THAN 100' (30 METERS)	18	TEMPERATURE RATING
MORE THAN 100' (30 METERS)	16	35°C MINIMUM.

- A** Run 24VAC control wires through cutout with grommet.
- B** Run 24VAC control wires through wire tie.
- C** Make 24VAC control wire connections using field provided wire nuts.
- D** Tighten wire tie to security 24V control wiring.

**NOTE** - FOR PROPER VOLTAGES, SELECT THERMOSTAT WIRE (CONTROL WIRES) GAUGE PER TABLE ABOVE.

**NOTE** - WIRE TIE PROVIDES LOW VOLTAGE WIRE STRAIN RELIEF AND TO MAINTAIN SEPARATION OF FIELD INSTALLED LOW AND HIGH VOLTAGE CIRCUITS.

**NOTE** - DO NOT BUNDLE ANY EXCESS 24VAC CONTROL WIRES INSIDE CONTROL BOX.

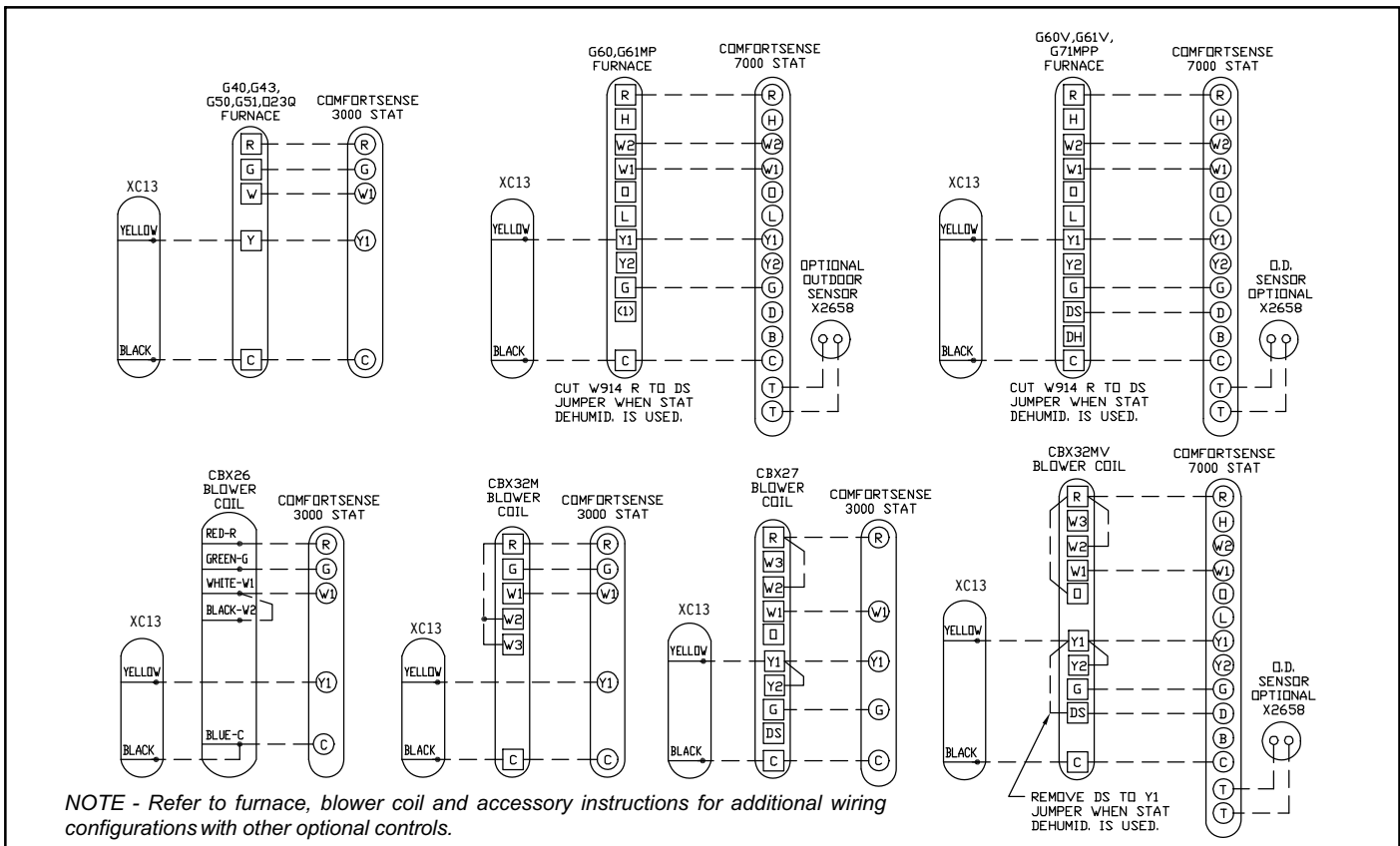

Figure 14. 24VAC Control Wiring Diagrams (Field Installed)

### Servicing Units Void of Charge

If the outdoor unit is void of refrigerant, clean the system using the procedure described below.

1. Leak check system using procedure outlined on page 21.
2. Evacuate the system using procedure outlined on page 22.
3. Use nitrogen to break the vacuum and install a new filter drier in the system.
4. Evacuate the system again using procedure outlined on page 22.
5. Weigh in refrigerant using procedure outlined in figure 18.
6. Monitor the system to determine the amount of moisture remaining in the oil. It may be necessary to replace the filter drier several times to achieve the required dryness level. **If system dryness is not verified, the compressor will fail in the future.**

### Unit Start-Up

## ⚠ IMPORTANT

If unit is equipped with a crankcase heater, it should be energized 24 hours before unit start-up to prevent compressor damage as a result of slugging.

1. Rotate fan to check for binding.
2. Inspect all factory- and field-installed wiring for loose connections.
3. After evacuation is complete, open both the liquid and vapor line service valves to release the refrigerant charge contained in outdoor unit into the system.
4. Replace the stem caps and tighten to the value listed in table 1.
5. Check voltage supply at the disconnect switch. The voltage must be within the range listed on the unit's nameplate. If not, do not start the equipment until you have consulted with the power company and the voltage condition has been corrected.
6. Set the thermostat for a cooling demand. Turn on power to the indoor indoor unit and close the outdoor unit disconnect switch to start the unit.
7. Recheck voltage while the unit is running. Power must be within range shown on the nameplate.
8. Check system for sufficient refrigerant by using the procedures listed under *System Charge*.

### System Refrigerant

This section outlines procedures for:

1. Connecting gauge set for testing and charging;
2. Checking and adjusting indoor airflow;
3. Adding or removing refrigerant.



# GAUGE SET

## CONNECTIONS FOR TESTING AND CHARGING

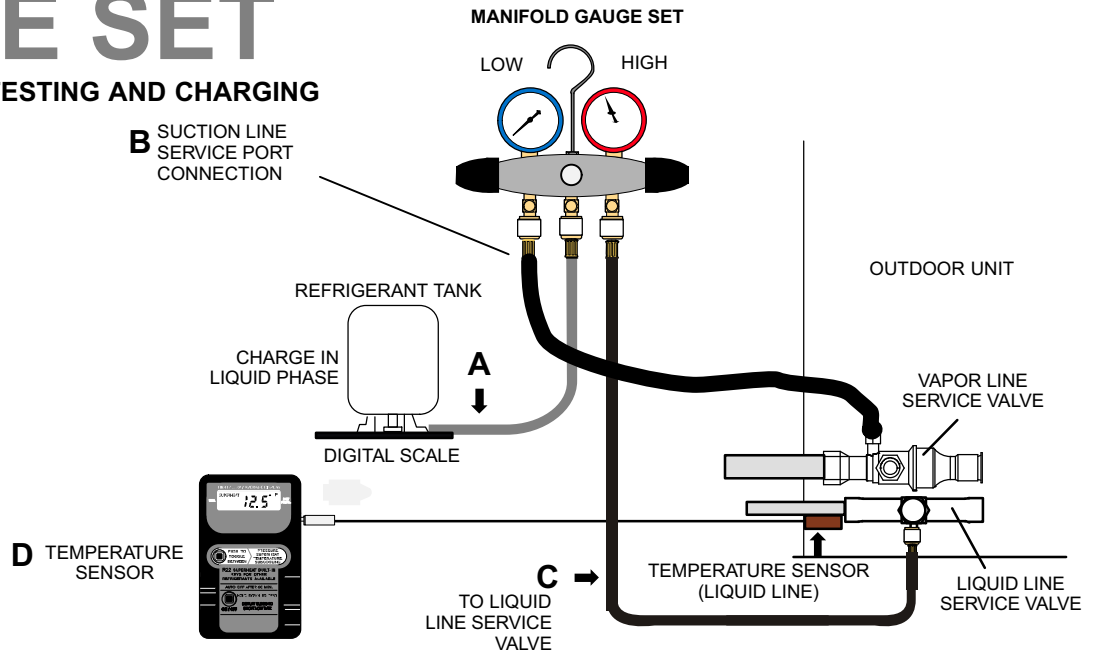

- A** Close manifold gauge set valves and connect the center hose to a cylinder of HFC-410A. Set for liquid phase charging.
- B** Connect the manifold gauge set's low pressure side to the suction line service port.
- C** Connect the manifold gauge set's high pressure side to the liquid line service port.
- D** Position temperature sensor on liquid line near liquid line service port.

**Figure 15. Gauge Set Setup and Connections**

## ADDING OR REMOVING REFRIGERANT

This system uses HFC-410A refrigerant which operates at much higher pressures than HCFC-22. The pre-installed liquid line filter drier is approved for use with HFC-410A only. Do not replace it with components designed for use with HCFC-22. This unit is NOT approved for use with coils which use capillary tubes or fixed orifices as a refrigerant metering device. Check airflow using the Delta-T (DT) process using the illustration in figure 16.

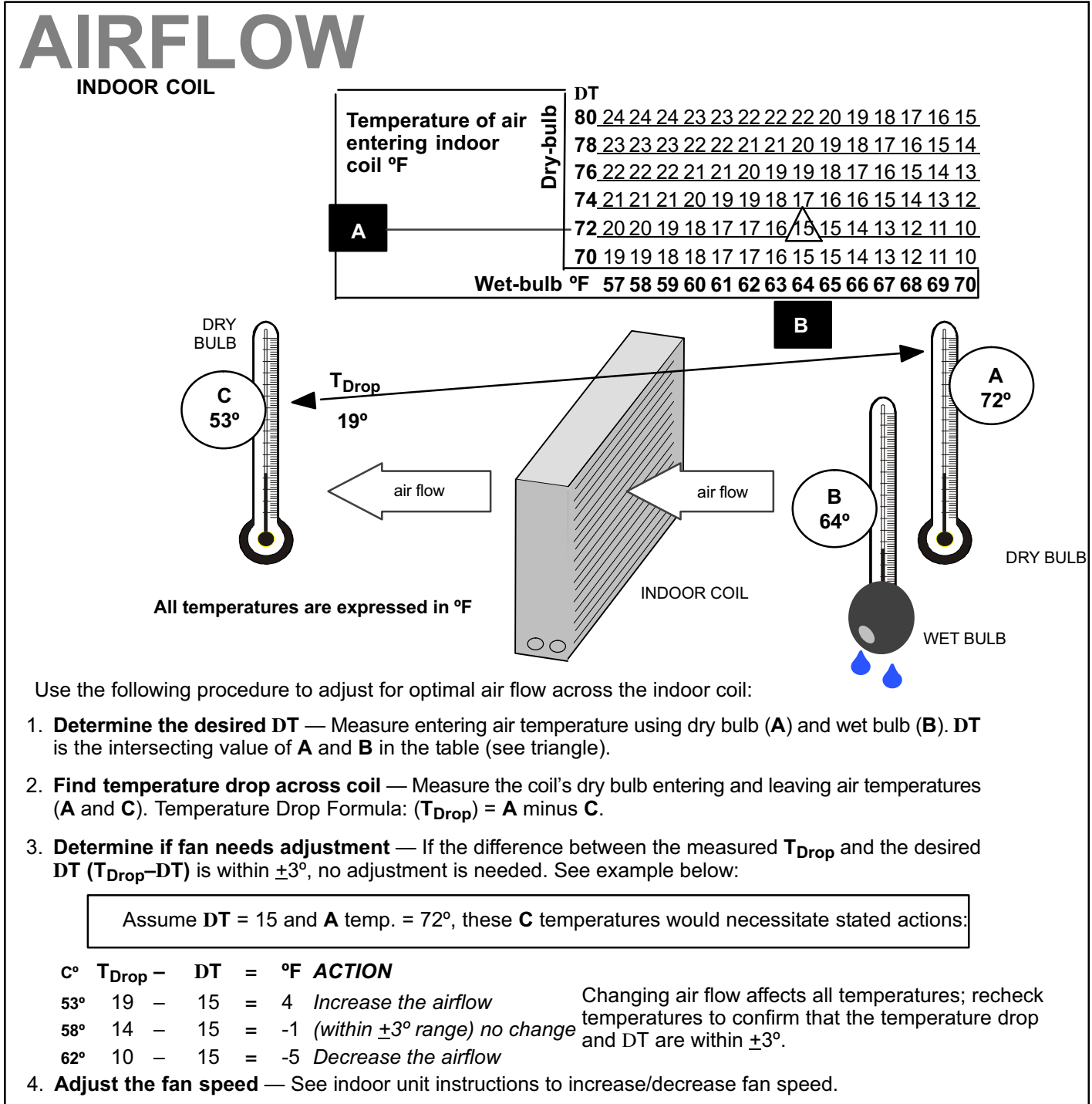

Figure 16. Checking Indoor Airflow over Evaporator Coil using Delta-T Chart

# DETERMINING CHARGE METHOD

**START: Determine how refrigerant is metered**

## WHEN TO CHARGE?

- Warm weather best
- Can charge in colder weather

## CHARGE METHOD? Determine by:

- Metering device type
- Outdoor ambient temperature

## REQUIREMENTS:

- Sufficient heat load in structure
- Indoor temperature between 70-80°F (21-26°C)
- Manifold gauge set connected to unit
- Thermometers:
  - to measure outdoor ambient temperature
  - to measure liquid line temperature
  - to measure suction line temperature

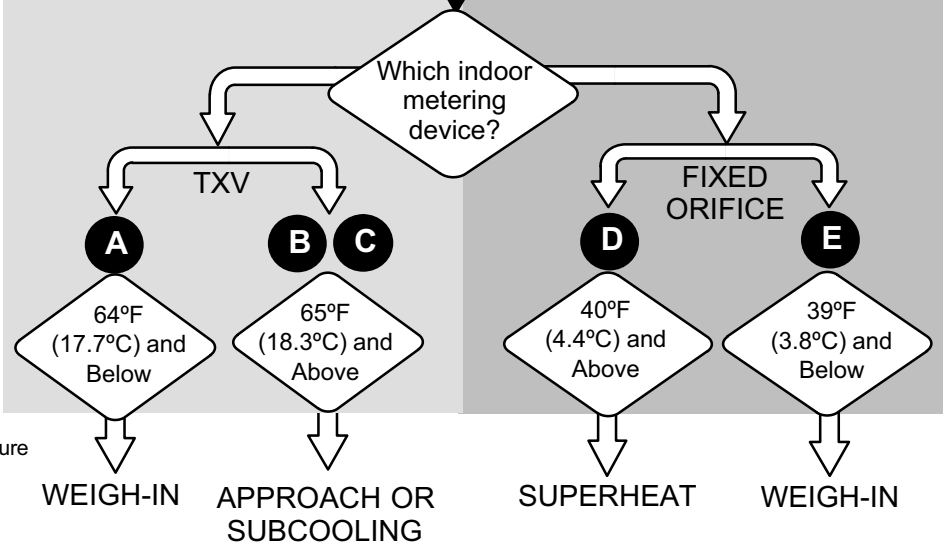

Figure 17. Determining Charge Method

# A WEIGH IN

## E CHARGING METHOD

### CALCULATING SYSTEM CHARGE FOR OUTDOOR UNIT VOID OF CHARGE

If the system is void of refrigerant, first, locate and repair any leaks and then weigh in the refrigerant charge into the unit. To calculate the total refrigerant charge:

$$\text{Amount specified on nameplate} \pm \text{Adjust amount for variation in line set length listed on line set length table below} = \text{Total charge}$$

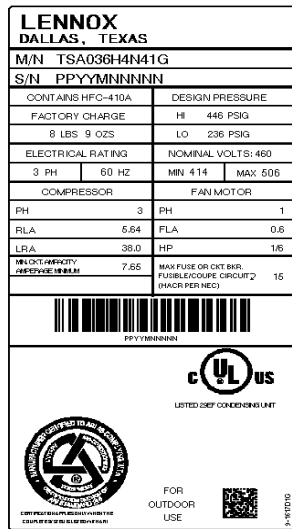

### Refrigerant Charge per Line Set Length

Liquid Line Set Diameter	Ounces per 5 feet (g per 1.5 m) adjust from 15 feet (4.6 m) line set*
3/8" (9.5 mm)	3 ounce per 5' (85 g per 1.5 m)

\*If line length is greater than 15 ft. (4.6 m), add this amount. If line length is less than 15 ft. (4.6 m), subtract this amount.

**NOTE** — Insulate liquid line when it is routed through areas where the surrounding ambient temperature could become higher than the temperature of the liquid line or when pressure drop is equal to or greater than 20 psig.

**NOTE** — The above nameplate is for illustration purposes only. Go to actual nameplate on outdoor unit for charge information.

Figure 18. Using HFC-410A Weigh In Method

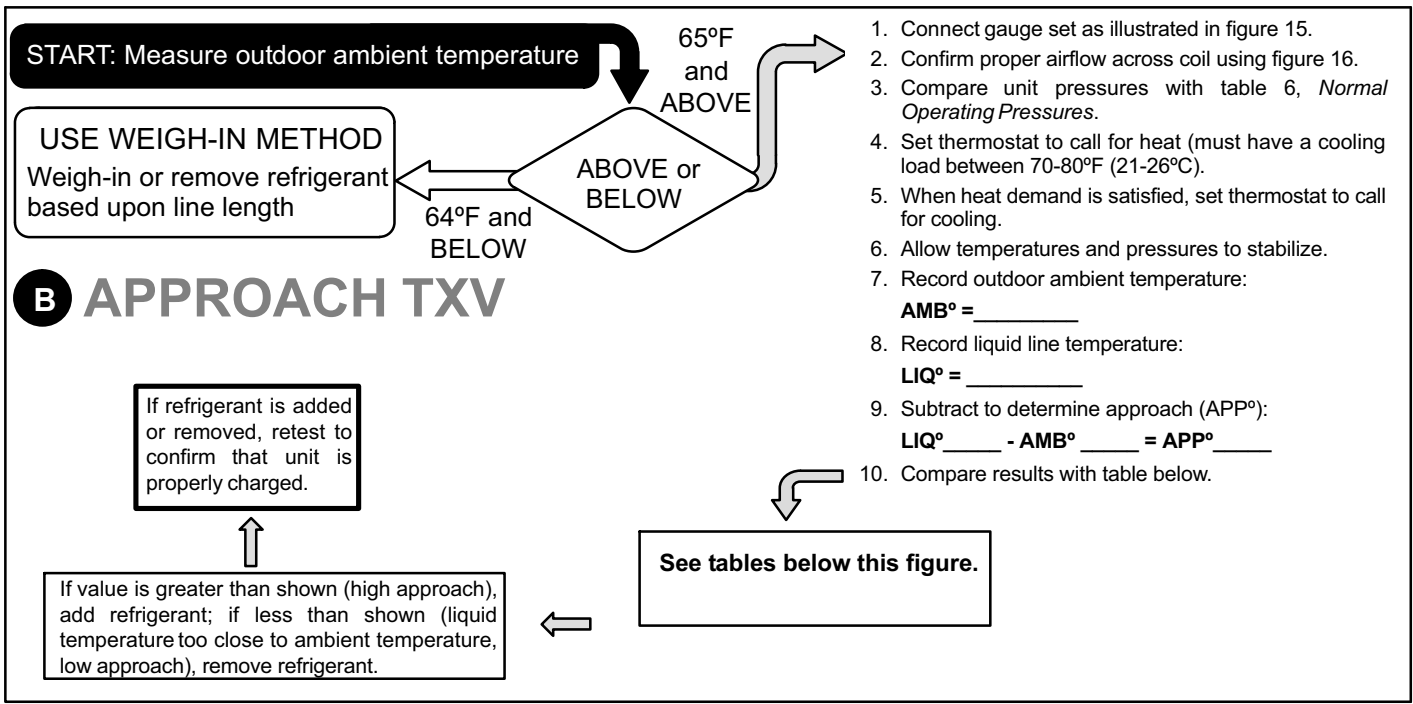

**Figure 19. Using HFC-410A Approach (TXV) Charge Method**

Model XC13-XXX-230-XX	-18-01	-18-02, -03	-24-01	-24-02, -03, -04	-30-01, -02	-30-03, -04	-36-01	-36-02	-36-03, -04
<b>Approach (APP) Values* - TXV System - °F (°C) ±1°F (0.5°C)</b>									
Temp. °F (°C)	3 (1.7)	4 (2.2)	6 (3.3)	8 (4.4)	11 (6)	8 (4.4)	7 (4)	7 (3.9)	11 (6.1)
*Approach = Liquid Line Temp. minus Outdoor Ambient Temperature									

Model XC13-XXX-230-XX	-42-01, -02	-42-03, -04	-48-01, -02	-48-03, -04	-60-01	-60-02, -03	-60-04, -05
<b>Approach (APP) Values* - TXV System - °F (°C) ±1°F (0.5°C)</b>							
Temp. °F (°C)	7 (3.9)	7 (3.9)	10 (5.5)	8 (4.4)	10 (5.5)	7 (3.9)	9 (5.0)
*Approach = Liquid Line Temp. minus Outdoor Ambient Temperature							

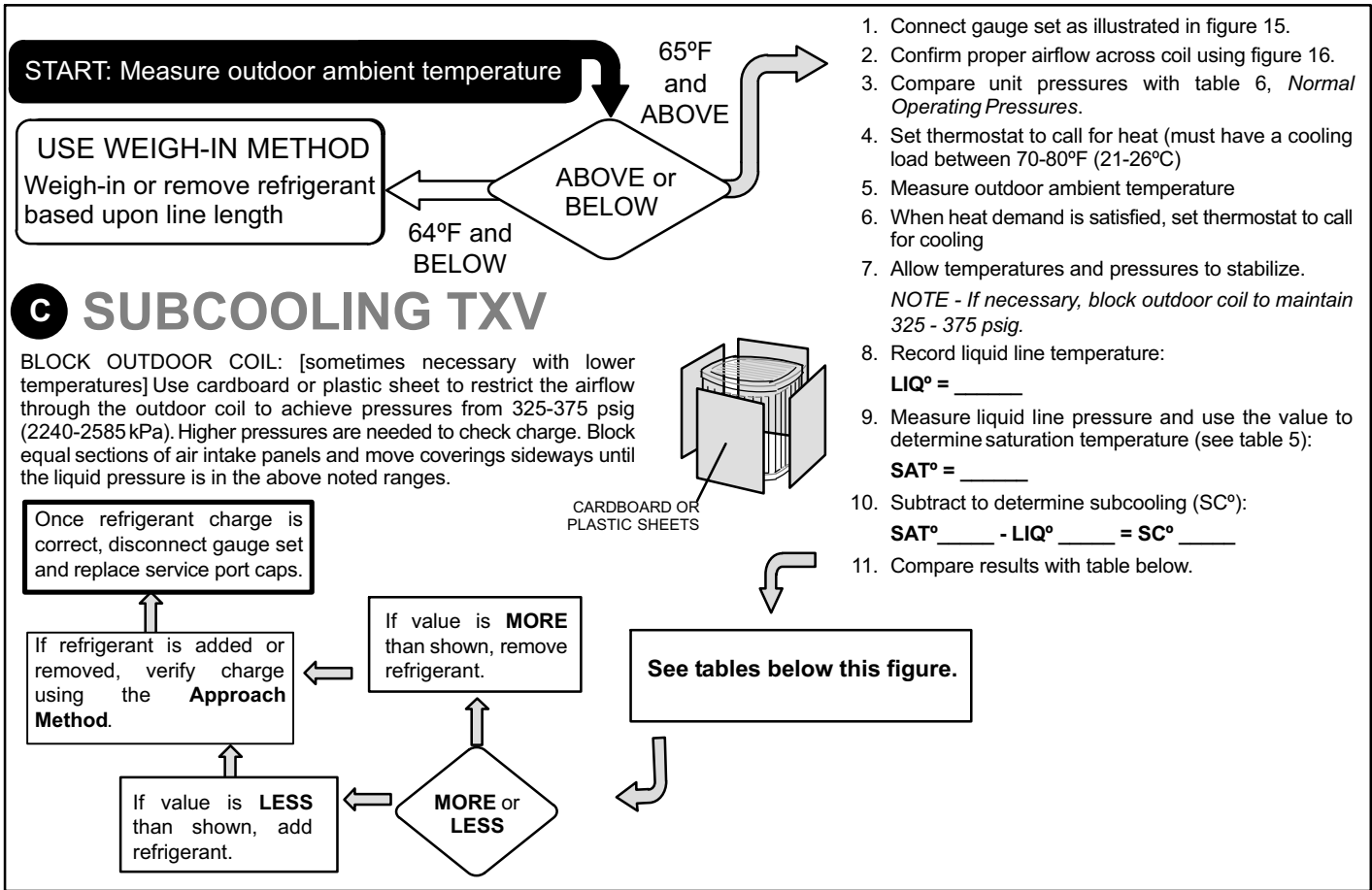
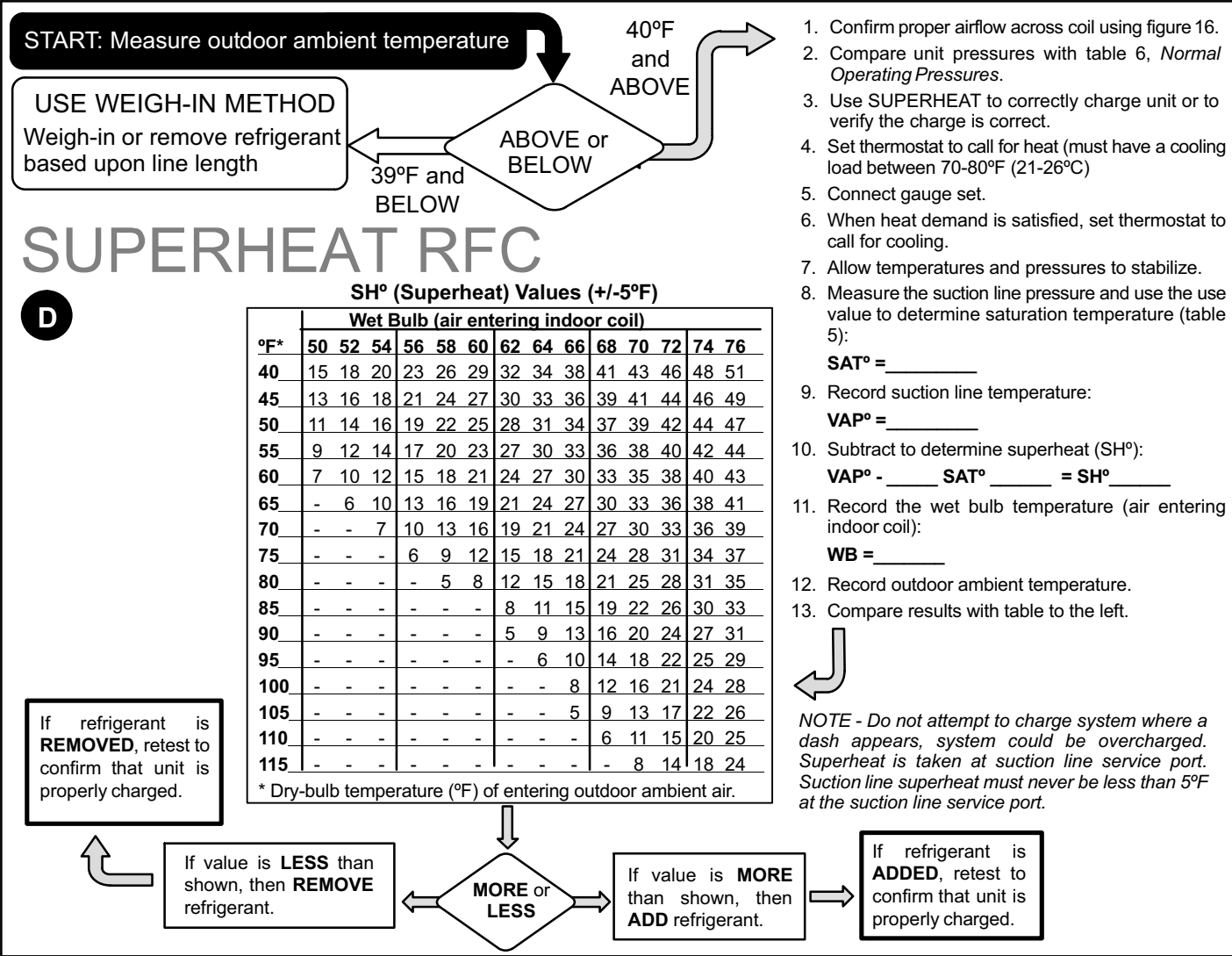

Figure 20. Using HFC-410A Subcooling (TXV) Charge Method

Model XC13-XXX-230-XX	-18-01	-18-02, -03	-24-01	-24-02, -03, -04	-30-01, -02	-30-03, -04	-36-01, -02	-36-03, -04
<b>Table 3- Subcooling (SC) Values* - TXV System - °F (°C) ±1°F (0.5°C)</b>								
<b>Temp. °F (°C)</b>	12 (6.7)	10 (5.6)	12 (6.7)	10 (5.6)	7 (3.9)	9 (5.0)	10 (5.5)	12 (6.7)
*Subcooling = Saturation Temp. minus Liquid Line Temp Temperature								

Model XC13-XXX-230-XX	-42-01, -02	-42-03, -04	-48-01, -02	-48-03, -04	-60-01, -02, -03	-60-04, -05
<b>Table 4- Subcooling (SC) Values* - TXV System - °F (°C) ±1°F (0.5°C)</b>						
<b>Temp. °F (°C)</b>	7 (3.9)	8 (4.4)	7 (3.9)	9 (5.0)	9 (5)	7 (3.9)
*Subcooling = Saturation Temp. minus Liquid Line Temp Temperature						



**Figure 21. Using HFC-410A Superheat (Fixed Orifice) Charge Method**

**Table 5. HFC-410A Temperature (°F) - Pressure (Psig)**

°F	Psig	°F	Psig	°F	Psig	°F	Psig	°F	Psig	°F	Psig	°F	Psig	°F	Psig
32	100.8	48	137.1	63	178.5	79	231.6	94	290.8	110	365.0	125	445.9	141	545.6
33	102.9	49	139.6	64	181.6	80	235.3	95	295.1	111	370.0	126	451.8	142	552.3
34	105.0	50	142.2	65	184.3	81	239.0	96	299.4	112	375.1	127	457.6	143	559.1
35	107.1	51	144.8	66	187.7	82	242.7	97	303.8	113	380.2	128	463.5	144	565.9
36	109.2	52	147.4	67	190.9	83	246.5	98	308.2	114	385.4	129	469.5	145	572.8
37	111.4	53	150.1	68	194.1	84	250.3	99	312.7	115	390.7	130	475.6	146	579.8
38	113.6	54	152.8	69	197.3	85	254.1	100	317.2	116	396.0	131	481.6	147	586.8
39	115.8	55	155.5	70	200.6	86	258.0	101	321.8	117	401.3	132	487.8	148	593.8
40	118.0	56	158.2	71	203.9	87	262.0	102	326.4	118	406.7	133	494.0	149	601.0
41	120.3	57	161.0	72	207.2	88	266.0	103	331.0	119	412.2	134	500.2	150	608.1
42	122.6	58	163.9	73	210.6	89	270.0	104	335.7	120	417.7	135	506.5	151	615.4
43	125.0	59	166.7	74	214.0	90	274.1	105	340.5	121	423.2	136	512.9	152	622.7
44	127.3	60	169.6	75	217.4	91	278.2	106	345.3	122	428.8	137	519.3	153	630.1
45	129.7	61	172.6	76	220.9	92	282.3	107	350.1	123	434.5	138	525.8	154	637.5
46	132.2	62	175.4	77	224.4	93	286.5	108	355.0	124	440.2	139	532.4	155	645.0
47	134.6			78	228.0			109	360.0			140	539.0		

**Table 6. Normal Operating Pressures (Liquid +10 and Suction +5 psig)**

Model Size XC13-XXX-230-XX	-18-01	-18-02, -03	-24-01	-24-02, -03, -04	-30-01	-30-02	-30-03, -04	-36-01	-36-02	-36-03, -04
<b>Table 7- Normal Operating Pressures**</b>										
°F(°C)*	<b>TXV System - Liquid Line (±10 psig) / Suction Line (±5 psig)</b>									
65 (18)	237/135	233/132	244/136	244/137	239/124	243/131	248/127	251/129	238/133	263/135
75 (24)	275/137	265/133	283/138	285/139	277/129	281/132	284/132	291/135	278/135	302/140
85 (29)	317/139	314/136	326/141	329/141	320/135	325/134	330/135	334/139	324/137	349/142
95 (35)	363/142	362/138	376/142	379/143	365/140	372/136	380/137	383/143	374/139	404/144
105 (41)	413/144	415/141	428/144	438/145	414/143	422/139	434/139	435/147	429/142	462/147
115 (46)	471/147	475/143	486/146	495/148	468/147	478/141	497/142	490/150	500/144	527/150
°F(°C) <sup>2</sup>	<b>Fixed Orifice - Liquid Line (±10 psig) / Suction Line (±5 psig)</b>									
65 (18)	238/130	233/121	249/126	246/126	243/131	239/124	245/123	238/133	251/129	261/134
75 (24)	273/134	270/128	288/133	286/132	281/132	277/129	286/129	278/135	291/135	301/138
85 (29)	316/141	313/134	331/138	330/137	325/134	320/135	331/135	324/137	334/139	346/142
95 (35)	363/147	359/138	379/143	378/142	372/136	365/140	380/140	374/139	383/143	396/146
105 (41)	411/151	409/142	425/147	428/145	422/139	414/143	431/144	429/142	435/147	448/150
115 (46)	467/155	464/147	481/150	486/149	478/141	468/147	487/148	500/144	490/150	506/153
*Temperature of the air entering the outside coil.										
**Typical pressures; indoor unit match up, indoor air quality equipment, and indoor load causes pressure variance										
Model Size XC13-XXX-230-XX	-42-01	-42-02	-42-03, -04	-48-01	-48-02	-48-03, -04	-60-01	-60-02	-60-03	-60-04, -05
<b>Table 8- Normal Operating Pressures**</b>										
°F(°C)*	<b>TXV System - Liquid Line (±10 psig) / Suction Line (±5 psig)</b>									
65 (18)	240/120	231/129	235/128	249/123	247/130	235/132	243/117	242/130	242/130	241/130
75 (24)	280/128	269/131	268/130	286/129	281/134	276/134	285/123	286/132	286/132	280/132
85 (29)	323/133	314/134	313/133	328/133	325/137	323/135	329/129	332/134	332/134	321/135
95 (35)	368/137	362/135	364/134	372/137	386/139	377/138	376/134	381/136	381/136	371/135
105 (41)	417/141	409/139	416/136	419/141	428/141	430/141	427/137	433/138	433/138	428/139
115 (46)	468/144	463/142	473/139	475/145	485/144	495/143	485/141	488/141	488/141	484/142
°F(°C) <sup>2</sup>	<b>Fixed Orifice - Liquid Line (±10 psig) / Suction Line (±5 psig)</b>									
65 (18)	231/129	240/120	236/119	247/130	249/123	247/125	250/125	255/126	255/126	248/124
75 (24)	269/131	280/128	269/124	281/134	286/129	286/131	291/127	294/131	294/131	288/130
85 (29)	314/134	323/133	312/130	325/137	328/133	329/135	334/130	339/136	339/136	330/135
95 (35)	362/135	368/137	360/136	386/139	372/137	377/140	383/133	386/140	386/140	377/140
105 (41)	409/139	417/141	413/141	428/141	419/141	428/144	434/136	435/144	435/144	431/144
115 (46)	463/142	468/144	466/145	485/144	475/145	483/147	489/139	490/148	490/148	484/148
*Temperature of the air entering the outside coil.										
**Typical pressures; indoor unit match up, indoor air quality equipment, and indoor load causes pressure variance										

## System Operation

The outdoor unit and indoor blower cycle on demand from the room thermostat. When the thermostat blower switch is in the **ON** position, the indoor blower operates continuously.

### HIGH PRESSURE SWITCH

XC13 units are equipped with a high-pressure switch that is located in the liquid line of the compressor as illustrated in *Unit Dimensions* on page 5. The switch is a Single Pole, Single Throw (SPST), manual-reset switch with red cap that is normally closed and removes power from the compressor when discharge pressure rises above factory setting at  $590 \pm 10$  psi.

### DISCHARGE THERMOSTAT

Each XC13 unit is equipped with a discharge thermostat located in the discharge line of the compressor. The switch (SPST, auto-reset, normally closed) and removes power from the compressor when discharge temperature exceeds the factory setting of  $220^{\circ}\text{F} \pm 5^{\circ}\text{F}$ .

### CRANKCASE THERMOSTAT (S40) (-060-01, -060-02 AND -060-03 UNITS ONLY)

Compressor in the above reference units are equipped with a 70 watt, belly band type crankcase heater. HR1 prevents liquid from accumulating in the compressor. HR1 is controlled by a thermostat located on the liquid line. When liquid line temperature drops below  $50^{\circ}\text{F}$  the thermostat closes energizing HR1. The thermostat will open, de-energizing HR1 once liquid line temperature reaches  $70^{\circ}\text{F}$ .

### FILTER DRIER

A filter drier is factory-installed as illustrated in *Unit Dimensions* on page 5, with each XC13 unit to ensure a clean, moisture-free system. A replacement filter drier is available from Lennox. Refer to Lennox Repair Part Program.

## Maintenance

### DEALER

Maintenance and service must be performed by a qualified installer or service agency. At the beginning of each cooling season, the system should be checked as follows:

#### Outdoor Unit

1. Clean and inspect the outdoor coil. The coil may be flushed with a water hose. Ensure the power is turned off before you clean the coil.

2. Outdoor fan motor is prelubricated and sealed. No further lubrication is needed.
3. Visually inspect connecting lines and coils for evidence of oil leaks.
4. Check wiring for loose connections.
5. Check for correct voltage at the unit (with the unit operating).
6. Check amp-draw outdoor fan motor.

**UNIT NAMEPLATE:** \_\_\_\_\_ **ACTUAL:** \_\_\_\_\_

*NOTE - If owner reports insufficient cooling, the unit should be gauged and refrigerant charge checked.*

#### Outdoor Coil

It may be necessary to flush the outdoor coil more frequently if it is exposed to substances which are corrosive or which block airflow across the coil (e.g., pet urine, cottonwood seeds, fertilizers, fluids that may contain high levels of corrosive chemicals such as salts)

- Outdoor Coil — The outdoor coil may be flushed with a water hose.
- Outdoor Coil (Sea Coast) — Moist air in ocean locations can carry salt, which is corrosive to most metal. Units that are located near the ocean require frequent inspections and maintenance. These inspections will determine the necessary need to wash the unit including the outdoor coil. Consult your installing contractor for proper intervals/procedures for your geographic area or service contract.

#### INDOOR UNIT

1. Clean or change filters.
2. Adjust blower speed for cooling. Measure the pressure drop over the coil to determine the correct blower CFM. Refer to the unit information service manual for pressure drop tables and procedure.
3. Check blower drive belt for wear and proper tension.
4. Check all wiring for loose connections
5. Check for correct voltage at unit (blower operating).
6. Check amp-draw on blower motor.

**UNIT NAMEPLATE:** \_\_\_\_\_ **ACTUAL:** \_\_\_\_\_

#### INDOOR COIL

1. Clean coil, if necessary.
2. Check connecting lines and coils for signs of oil leaks.
3. Check condensate line and clean, if necessary.



## Start-Up and Performance Checklist

Job Name \_\_\_\_\_ Job no. \_\_\_\_\_ Date \_\_\_\_\_

Job Location \_\_\_\_\_ City \_\_\_\_\_ State \_\_\_\_\_

Installer \_\_\_\_\_ City \_\_\_\_\_ State \_\_\_\_\_

Unit Model No. \_\_\_\_\_ Serial No. \_\_\_\_\_ Service Technician \_\_\_\_\_

Nameplate Voltage \_\_\_\_\_

Rated Load Ampacity \_\_\_\_\_ Compressor \_\_\_\_\_ Outdoor Fan \_\_\_\_\_

Maximum Fuse or Circuit Breaker \_\_\_\_\_

Electrical Connections Tight?  Indoor Filter clean?  Supply Voltage (Unit Off) \_\_\_\_\_

Indoor Blower RPM \_\_\_\_\_ S.P. Drop Over Indoor (Dry) \_\_\_\_\_ Outdoor Coil Entering Air Temp. \_\_\_\_\_

Discharge Pressure \_\_\_\_\_ Suction Pressure \_\_\_\_\_ Refrigerant Charge Checked?

<b>Refrigerant Lines:</b> - Leak Checked? <input type="checkbox"/> Properly Insulated? <input type="checkbox"/>	Outdoor Fan Checked? <input type="checkbox"/>
---	---

<b>Service Valves:</b> --- Fully Opened? <input type="checkbox"/> Caps Tight? <input type="checkbox"/>	<b>Thermostat</b>
--	-------------------

Voltage With Compressor Operating _____	Calibrated? <input type="checkbox"/> Properly Set? <input type="checkbox"/> Level? <input type="checkbox"/>
---	---

# Unit Wiring Diagrams and Sequence of Operations

## XC13

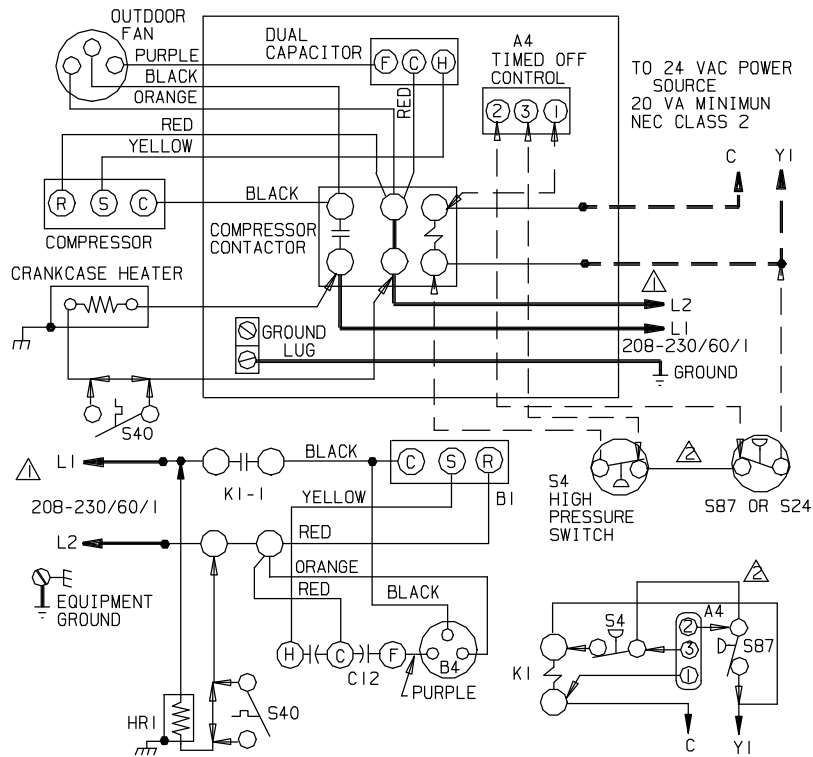

KEY	DESCRIPTION
A4	CONTROL-TIMED OFF
B1	COMPRESSOR
B4	MOTOR-OUTDOOR FAN
C12	CAPACITOR-DUAL
HR1	HEATER-COMPRESSOR
K1, -1	CONTACTOR-COMPRESSOR
S4	SWITCH-HIGH PRESSURE
S24	SWITCH-LOSS OF CHARGE
S40	THERMOSTAT-CRANKCASE
S87	SWITCH-LOW PRESS, COMP

⚠ FOR USE WITH COPPER CONDUCTORS ONLY. REFER TO UNIT RATING PLATE FOR MINIMUM CIRCUIT AMPACITY AND MAXIMUM OVERCURRENT PROTECTION SIZE.

⚡ JUMPER IS USED WHEN TOC IS NOT USED

WARNING-ELECTRIC SHOCK HAZARD, CAN CAUSE INJURY OR DEATH. UNIT MUST BE GROUNDED IN ACCORDANCE WITH NATIONAL AND LOCAL CODES.

———— LINE VOLTAGE FIELD INSTALLED  
 - - - - CLASS II VOLTAGE FIELD INSTALLED

← INDICATES OPTIONAL COMPONENTS

09/05	Supersedes Form No.
	New Form No.
	534,773W

© 2005

Litho U.S.A.

Figure 22. Unit Wiring Diagram (XC13-XXX-230-01, -02, and -03)

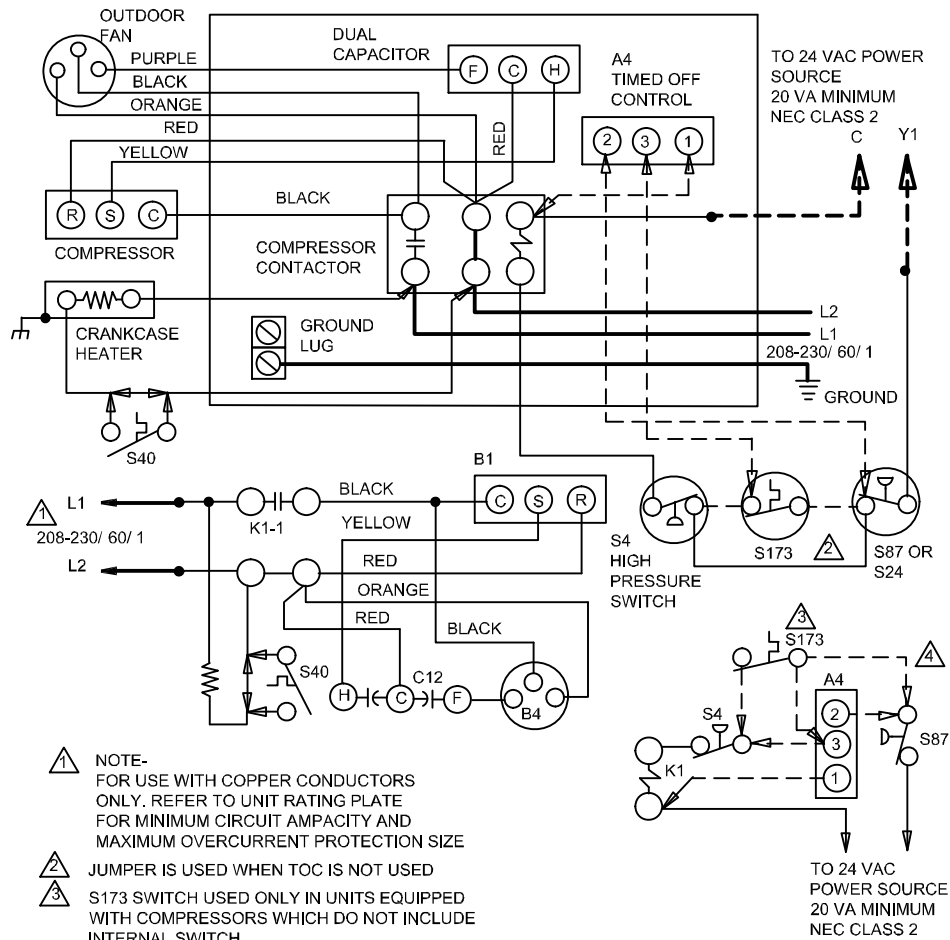

- ⚠ NOTE- FOR USE WITH COPPER CONDUCTORS ONLY. REFER TO UNIT RATING PLATE FOR MINIMUM CIRCUIT AMPACITY AND MAXIMUM OVERCURRENT PROTECTION SIZE
- ② JUMPER IS USED WHEN TOC IS NOT USED
- ③ S173 SWITCH USED ONLY IN UNITS EQUIPPED WITH COMPRESSORS WHICH DO NOT INCLUDE INTERNAL SWITCH
- ④ S173 TO S87 WHEN A4 IS NOT USED

DESCRIPTION	
KEY	COMPONENT
A4	CONTROL-TIMED OFF
B1	COMPRESSOR
B4	MOTOR-OUTDOOR FAN
C12	CAPACITOR-DUAL
HR1	HEATER-COMPRESSOR
K1.-1	CONTACTOR-COMPRESSOR
S4	SWITCH-HIGH PRESSURE
S24	SWITCH-LOSS OF CHARGE
S40	TERMOSTAT-CRANKCASE
S87	SWITCH-LOW PRESS. COMP 1
S173	SWITCH-THERMAL PROTECTION

NOTE- IF ANY WIRE IN THIS APPLIANCE IS REPLACED, IT MUST BE REPLACED WITH WIRE OF LIKE SIZE, RATING, INSULATION THICKNESS, AND TERMINATION.

— LINE VOLTAGE FIELD INSTALLED  
 - - - CLASS II VOLTAGE FIELD WIRING  
 ← DENOTES OPTIONAL COMPONENTS

1009	Supersedes
New Form No.	
537157-01	

© 2009 Litho U.S.A.

**Figure 23. Unit Wiring Diagram (XC13-XXX-230-04 or later)**

**UNIT SEQUENCE OF OPERATIONS**

**COOLING:**

- 1- Cooling demand initiates at Y1 in the thermostat.
- 1-- 24VAC from indoor unit (Y1) energizes the TOC timed off control (if used) , which energizes contactor K1.
- 2-- K1-1 N.O. closes, energizing compressor (B1) and outdoor fan motor (B4).

- 4 - Compressor (B1) and outdoor fan motor (B4) begin immediate operation..

**END OF COOLING DEMAND:**

- 5- Cooling demand is satisfied. Terminal Y1 is de-energized.
- 6- Compressor contactor K1 is de-energized.
- 7- K1-1 opens and compressor (B1) and outdoor fan motor (B4) are de-energized and stop immediately.