

See unit nameplate for manufacturer and address.

504,502M
8/2002
Supersedes 10/2001

USER'S INFORMATION MANUAL

GCS16-072, 090, 120, 150, 180, 240

(6, 7-1/2, 10, 12-1/2, 15, 20 TON)

ROOFTOP UNITS

⚠ WARNING

Improper installation, adjustment, alteration, service or maintenance can cause property damage, personal injury or loss of life. Installation and service must be performed by a qualified installer, service agency or the gas supplier

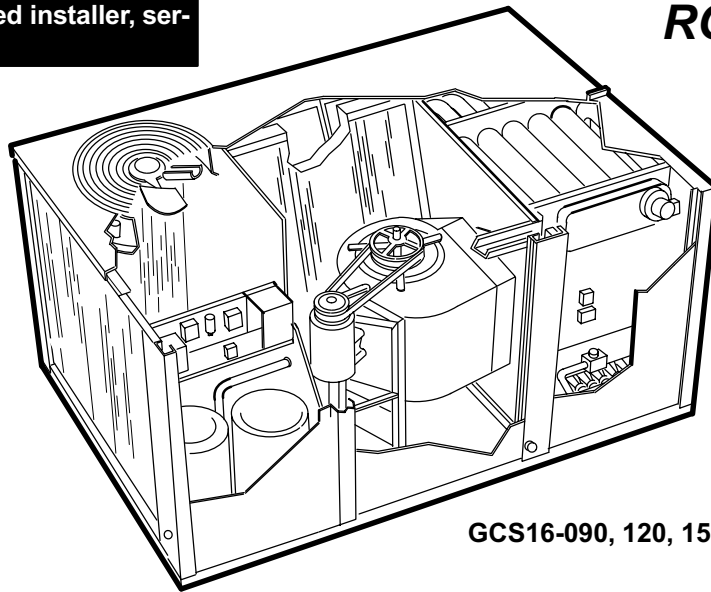

GCS16-090, 120, 150 SHOWN

**READ ALL INSTRUCTIONS IN THIS MANUAL
AND RETAIN FOR FUTURE REFERENCE**

TP Technical
Publications
Litho U.S.A.
©2002

FBR113270



⚠ WARNING

If the information in this manual is not followed exactly, a fire or explosion may result causing property damage, personal injury or loss of life.



Do not store or use gasoline or other flammable vapors and liquids in the vicinity of this or any other appliance.

Installation and service must be performed by a qualified installer, service agency or the gas supplier.

WHAT TO DO IF YOU SMELL GAS:

- Do not try to light any appliance.
- Extinguish any open flames.
- Do not touch any electrical switch; do not use any phone in your building.
- Leave the building immediately.
- Immediately call your gas supplier from a neighbor's phone. Follow the gas supplier's instructions.
- If you cannot reach your gas supplier, call the fire department.

08/02

504,502M



GCS16-072, 090, 120, 150 Parts Arrangement

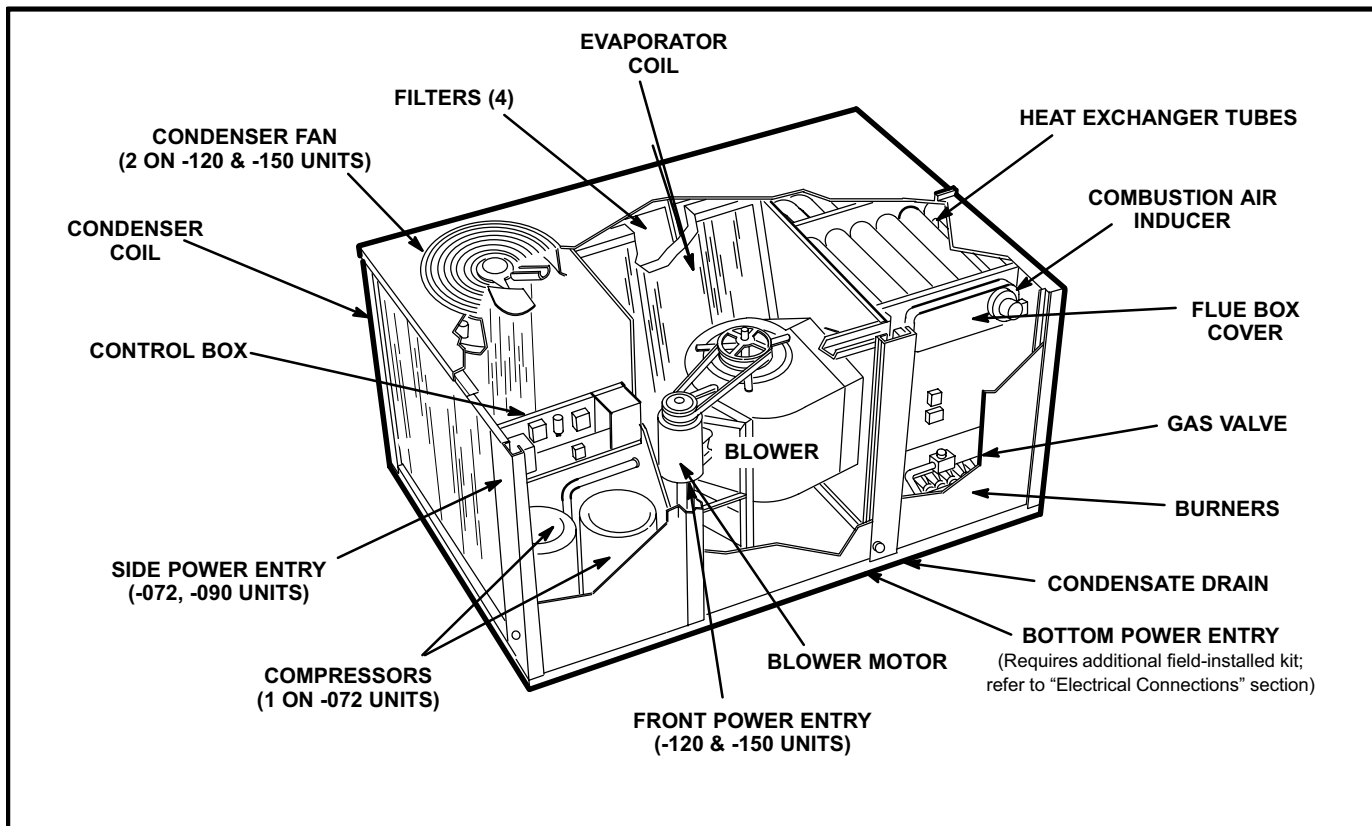

GCS16-180, 240 Parts Arrangement

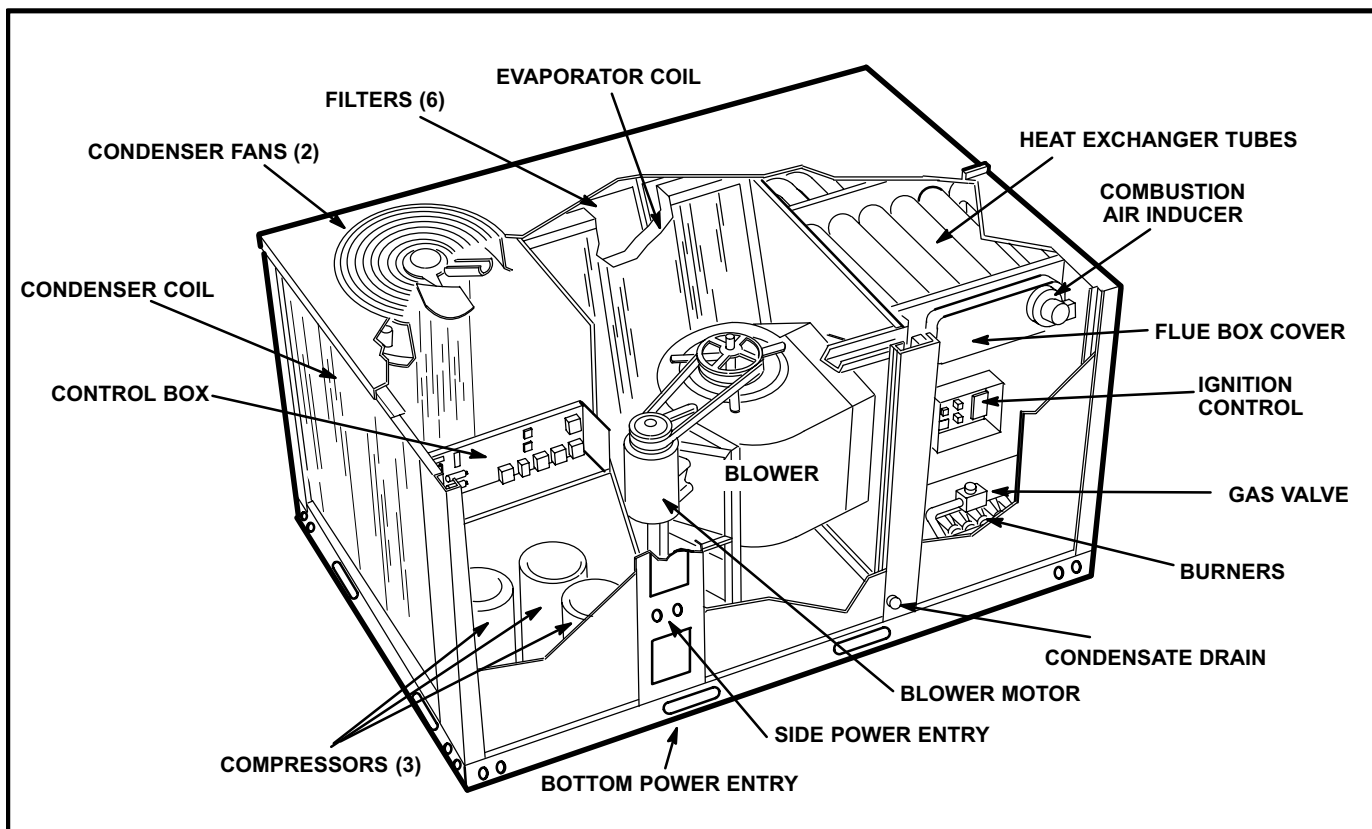

Safety

⚠️ WARNING



Danger of explosion and fire. Failure to follow safety warnings exactly could result in dangerous operation, serious injury, death or property damage.

- 1- Keep gas heat section clear and free of combustible materials, gasoline and other flammable vapors and liquids.
- 2- Inspect return air duct to ensure duct is sealed to the curb external to the unit.
- 3- Inspect physical support of unit to guarantee that it is sound without sagging, cracks, or gaps around base. On downflow units, seal between base and support must also be checked to make sure it is tight.
- 4- Do not obstruct air flow around unit. Unit must receive an unobstructed flow of combustion and ventilating air.

⚠️ CAUTION

Label all wires prior to disconnection when servicing controls. Wiring errors can cause improper and dangerous operation. Verify proper operation after servicing.

⚠️ WARNING



Danger of electrical shock, explosion and fire. Improper servicing could result in dangerous operation, serious injury, death or property damage.

⚠️ WARNING



Danger of explosion. Can cause injury or product or property damage. Should the gas supply fail to shut off or if overheating occurs, shut off the gas valve to the furnace before shutting off the electrical supply.

⚠️ WARNING



Electric shock hazard. Can cause injury or death. Before attempting to perform any service or maintenance, turn the electrical power to unit OFF at disconnect switch(es). Unit may have multiple power supplies.

⚠️ WARNING

Do not use this furnace if any part has been under water. A flood-damaged furnace is extremely dangerous. Attempts to use the furnace can result in fire or explosion. A qualified service agency should be contacted to inspect the furnace and to replace all gas controls, control system parts, electrical parts that have been wet or the furnace if deemed necessary.

⚠️ IMPORTANT

The Clean Air Act of 1990 bans the intentional venting of refrigerant (CFC's and HCFC's) as of July 1, 1992. Approved methods of recovery, recycling or reclaiming must be followed. Fines and/or incarceration may be levied for non-compliance.

⚠️ WARNING

Product contains fiberglass wool.

Disturbing the insulation in this product during installation, maintenance, or repair will expose you to fiberglass wool. Breathing this may cause lung cancer. (Fiberglass wool is known to the State of California to cause cancer.)

Fiberglass wool may also cause respiratory, skin, and eye irritation.

To reduce exposure to this substance or for further information, consult material safety data sheets available from addresses shown below, or contact your supervisor.

P.O. Box 799900
Dallas, TX 75379-9900

Unit Operation

FOR YOUR SAFETY READ BEFORE LIGHTING

BEFORE LIGHTING smell all around the furnace area for gas. Be sure to smell next to the floor because some gas is heavier than air and will settle on the floor.

Use only your hand to push in or turn the gas control knob. Never use tools. If the knob will not push in or turn by hand, do not try to repair it, call a qualified service technician. Force or attempted repair may result in a fire or explosion.

⚠️ WARNING

SMOKE POTENTIAL

The heat exchanger in this unit could be a source of smoke on initial firing. Take precautions with respect to building occupants and property. Vent initial supply air outside when possible.

⚠ WARNING



Danger of explosion. Can cause injury or death. Do not attempt to light manually. Unit has a direct spark ignition system.

This unit is equipped with an automatic spark ignition system. There is no pilot. In case of a safety shutdown, move thermostat switch to **OFF** and return the thermostat switch to **HEAT** to reset ignition control. See figure 1. For units which have electronic temperature control devices, shut off the main disconnect and return it to the on position to reset the ignition control.

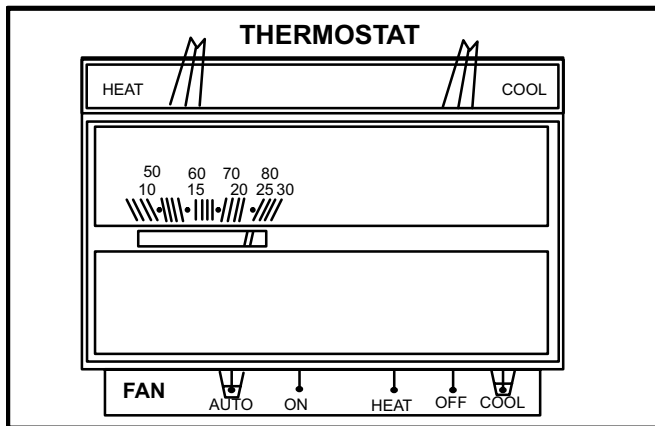

FIGURE 1

A-Placing Unit In Operation

⚠ WARNING



Danger of explosion and fire. Can cause injury or product or property damage. You must follow these instructions exactly.

Gas Valve Operation for White Rodgers 36C (figure 2) and Honeywell VR8305Q (figure 3)

- 1- Set thermostat to lowest setting.
- 2- Turn off all electrical power to furnace.
- 3- This furnace is equipped with an ignition device which automatically lights the burner. Do **not** try to light the burner by hand.
- 4- Open or remove the heat section access panel.
- 5- Turn the knob on the gas valve clockwise  to "OFF". Depress 36C knob slightly. Do not force.
- 6- Wait five (5) minutes to clear out any gas. If you then smell gas, **STOP!** Immediately call your gas supplier from a neighbor's phone. Follow the gas supplier's instructions. If you do not smell gas, go to the next step.

- 7- Turn the knob on the gas valve counterclockwise  to "ON". Do not force.
- 8- Close or replace the heat section access panel.
- 9- Turn on all electrical power to furnace.
- 10- Set thermostat to desired setting.
- 11- The combustion air inducer will start. The burners will light within 40 seconds.
- 12- If the furnace does not light the first time (gas line not fully purged), it will attempt up to two more ignitions before locking out.

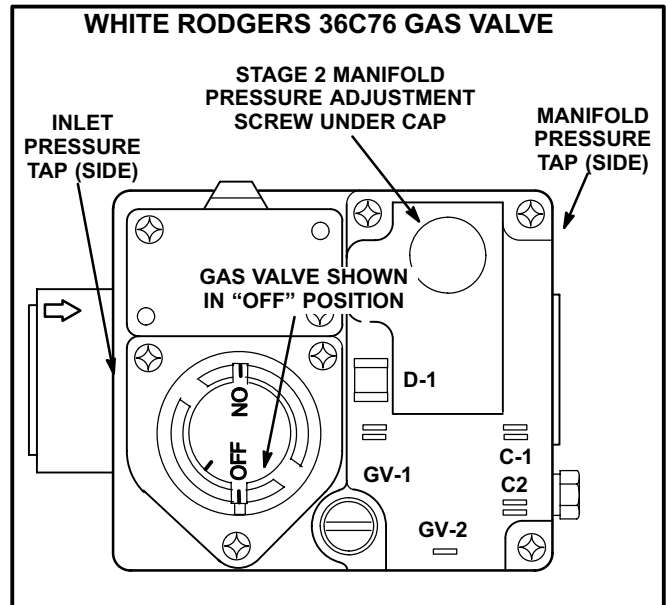

FIGURE 2

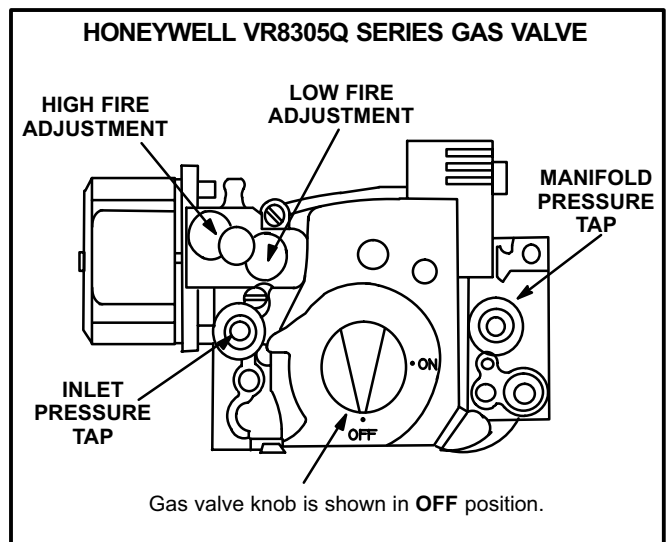



FIGURE 3

- 13- If lockout occurs, repeat steps 1 through 10.
- 14- If the furnace will not operate, follow the instructions "Turning Off Gas to Furnace" and call your service technician or gas supplier.

Turning Off Gas to Furnace

- 1- If using an electromechanical thermostat, set to the lowest setting.
- 2- Before performing any service, turn off all electrical power to the furnace.
- 3- Open or remove the heat section access panel.
- 4- Turn the knob on the gas valve clockwise  to "OFF". Depress 36C knob slightly. Do not force.
- 5- Replace heat section access panel.

Flue Passage And Vent Inspection

The combustion air pressure switch checks the combustion air inducer operation before allowing power to the ignition controller. Ignition controller will not operate if blower is obstructed.

Under normal operating conditions, the combustion air blower wheel should be inspected prior to heating season. With power supply disconnected, the condition of the blower wheel can be determined by removing the vent cap assembly and looking through the exhaust vent. Remove any deposits of debris from vent cap assembly before reinstalling it on unit. If cleaning combustion air inducer is necessary, contact a qualified service technician. See figure 4 and 5.

Burner Flame

WARNING



Danger of explosion. Can cause injury or product or property damage. Do not use matches, candles, flame or other sources of ignition to check for leaks.

WARNING



Danger of explosion and fire. Can cause injury or product or property damage. Periodically inspect burner flame to ensure proper unit operation.

The primary air is permanently set for normal operation. The flame will be basically blue with some clear yellow streaking in the end of the flame. Inspect burner flame periodically during heating season using inspection port provided on the burner access panel.

Service

CAUTION

Danger of sharp metallic edges. Can cause injury. Take care when servicing unit to avoid accidental contact with sharp edges.

To maintain efficiency and longevity, your equipment must be serviced yearly by a qualified service technician. Failure to provide proof of service can void warranty.

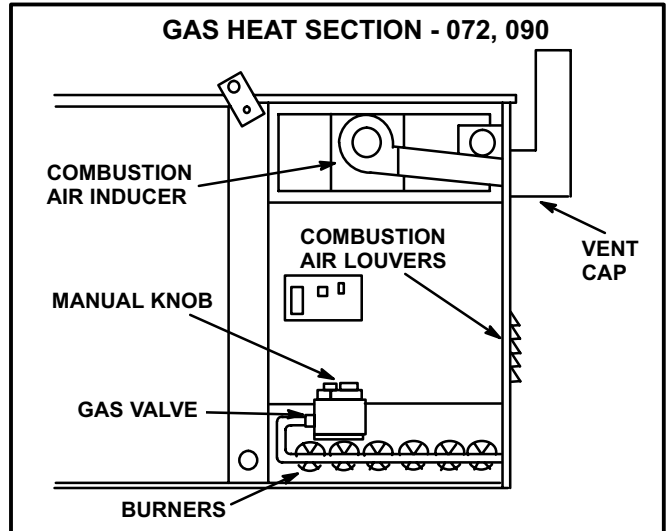

FIGURE 4

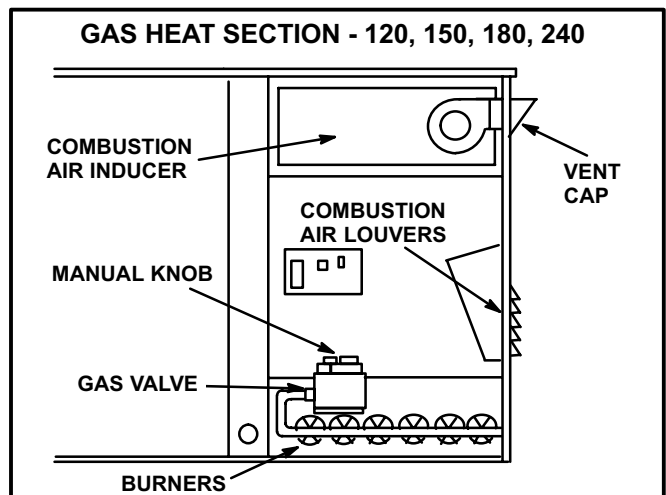

FIGURE 5

A-Servicing Filter

GCS16 units are equipped with pleated 2" throwaway-type filters. Filters should be checked monthly and replaced when necessary with filters of like kind and size. Take note of air flow direction marking on filter frame when reinstalling filters. See figure 6.

NOTE—Filters must be U.L.C. approved or equivalent for use in Canada.

**TABLE 1
FILTER SIZE**

Unit	Qty.	Filter Size - inches (mm)
072, 090	4	16 X 20 X 2 (406 X 508 X 51)
120	2	16 X 20 X 2 (406 X 508 X 51)
	2	16 X 25 X 2 (406 X 635 X 51)
150	2	20 X 20 X 2 (508 X 508 X 51)
	2	20 X 25 X 2 (508 X 635 X 51)
180, 240	6	18 X 24 X 2 (457 X 610 X 51)

B-Blower Motor

Blower motor is prelubricated. No further lubrication is required.

Service Reminder

Contact a qualified service technician if the unit is inoperative. Before calling, always check the following to be sure service is required:

- 1- Be sure electrical disconnect switches are ON.
- 2- Check room thermostat for proper setting.
- 3- Replace any blown fuses or reset circuit breakers.
- 4- Gas valve(s) should be ON for heating cycle.
- 5- Air filters should not be plugged, limiting air flow.
- 6- Make sure all access panels are in place.

To keep your heating and cooling system in peak operating condition year after year, contact a qualified service technician about a regular maintenance program.

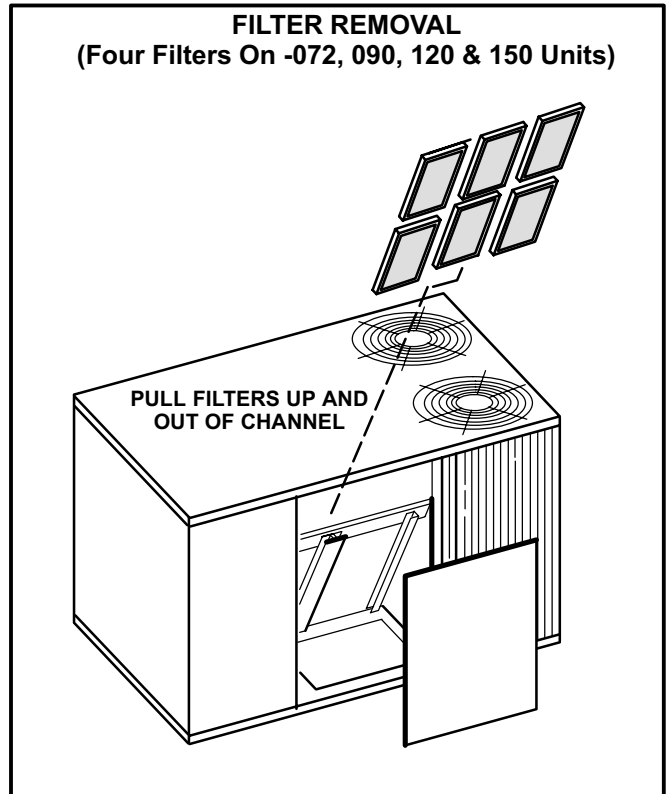

FIGURE 6

Repair Parts Listing

The following repair parts are available. When ordering parts, include the complete model number listed on either the CSA International rating plate (e.g. GCS16-240-375-1Y) or the U.L. C.S.A. rating plate (e.g. CHA16-240-1G)

Heat Section Parts

- | | | |
|------------------------|--------------------------|-------------------------------|
| Heat Exchanger | Sensor Lead | Auxiliary Limit Control (S21) |
| Combustion Air Inducer | Combination Gas Valve | Burner Manifold Assembly |
| Burner Assembly | Flue Baffle | Main Burner Orifices |
| Ignition Lead | Limit Control (S10) | Ignition Electrode Assembly |
| Ignition Control (A3) | CAB Proving Switch (s18) | Hi Heat Delay (DL3) |
| Rollout Switch (S47) | | |

Cooling Parts

- | | | |
|-------------------------------|-----------------------------------|-----------------------------|
| Compressor | Cond. Fan Run Capacitors (C1, C2) | Blower Wheel |
| High Pressure Switch (S4, S7) | Freezestat (S49, S50) | Expansion Valve Distributor |
| Condenser Fan Motor | Cond. Fan Mount. Bracket | Expansion Valve |
| Condenser Fan Blade | Fan Grille | Indoor Blower Motor |

Electrical Control Parts

- | | | |
|-------------------------------|------------------------------------|----------------------------------|
| Compressor Contactor (K1, K2) | Capacitor CAB (C3) | Blower Delay (K25) |
| Transformer (Control) T1 | Transformer (T3) (575/460V only) | Low Amb. Pressure Sw. (S11, S84) |
| Blower Contactor (K3) | Combustion Air Inducer Relay (K13) | Condenser Fan Contactor (K10) |
| Limit, Blower Relay (K20) | Firestat Switches (S74, S75) | Reversing Valve |
| Crankcase Heater Relay (K191) | | |