

TPA*S2 COMMERCIAL SERIES UNITS

The TPA*S2 is a commercial split-system heat pump. The series is designed for use with expansion valves (TXV). All TPA*S2 units utilize scroll compressors.

TPA*S2 series units are available in 3, 4 and 5 ton capacities. All major components (indoor blower and coil) must be matched according to Lennox recommendations for the compressor to be covered under warranty. Refer to the Engineering Handbook for approved system matchups.

This manual is divided into sections which discuss the major components, refrigerant system, charging procedure, maintenance and operation sequence.

Information contained in this manual is intended for use by qualified service technicians only. All specifications are subject to change.

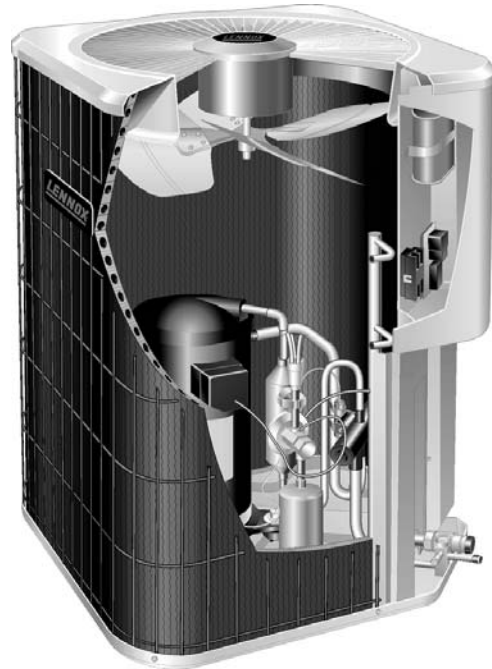

**ELECTROSTATIC DISCHARGE (ESD)
Precautions and Procedures**

⚠ CAUTION

Electrostatic discharge can affect electronic components. Take precautions during unit installation and service to protect the unit's electronic controls. Precautions will help to avoid control exposure to electrostatic discharge by putting the unit, the control and the technician at the same electrostatic potential. Neutralize electrostatic charge by touching hand and all tools on an unpainted unit surface before performing any service procedure.

⚠ WARNING

Refrigerant can be harmful if it is inhaled. Refrigerant must be used and recovered responsibly. Failure to follow this warning may result in personal injury or death.

⚠ CAUTION

In order to avoid injury, take proper precaution when lifting heavy objects.

Table of Contents

Specifications / Electrical Data Page 2
I Unit Components Page 4
II Refrigerant System Page 8
III Charging Page 10
IV Maintenance Page 12
V Diagrams Page 13

SPECIFICATIONS

General Data		Model No.	TPA036S2	TPA048S2	TPA060S2
Nominal Tonnage (kW)			3 (10.6)	4 (14.1)	5 (17.6)
Connections (sweat)	Liquid line o.d. - in. (mm)		3/8 (9.5)	3/8 (9.5)	3/8 (9.5)
	Vapor line o.d. - in. (mm)		7/8 (22.2)	7/8 (22.2)	1-1/8 (28.6)
² Refrigerant	R-22 charge furnished		8 lbs. 10 oz. (3.91 kg)	11 lbs. 12 oz. (5.33 kg)	14 lbs. 0oz. (6.3 kg)
Outdoor Coil	Net face area	Outer coil	15.21 (1.41)	21.11 (1.96)	24.94 (2.3)
	sq. ft. (m ²)	Inner coil	14.50 (1.35)	20.31 (1.89)	24.13 (2.24)
	Tube diameter - in. (mm)	no. of rows	5/16 (8) - 2	5/16 (8) - 2	5/16 (8) - 2
		Fins per inch (m)	22 (866)	22 (866)	22 (866)
Outdoor Fan	Diameter - in. (mm) - No. of Blades		18 (457) - 4	22 (559) - 4	26 (660) - 4
		Motor hp (W)	208/230V - 1/5 (149) 460V - 1/6 (124)	1/3 (249)	1/3 (249)
		Cfm (L/s)	2450 (1155)	3890 (1835)	4550 (2145)
		Rpm	1100	1085	830
		Watts	190	375	307
	Shipping Data - lbs. (kg) 1 package			178 (81)	248 (112)

ELECTRICAL DATA

Line voltage data - 60 hz - 3ph		208/230V	460V	208/230V	460V	208/230V	460V
³ Maximum overcurrent protection (amps)		20	10	30	15	40	15
⁴ Minimum circuit ampacity		13.1	6.5	20.0	9.5	23.4	9.2
Compressor	Rated Load Amps	9.6	4.8	14.7	7.0	17.3	6.7
	Locked Rotor Amps	77	35	91	50	123	49.5
	Power Factor	.96	.88	.96	.87	.96	.88
Outdoor Fan Motor	Full Load Amps	1.1	.55	1.7	.82	1.8	.9
	Locked Rotor Amps	1.9	1.1	4.1	2.2	2.9	2.3

OPTIONAL ACCESSORIES - must be ordered extra

Compressor Low Ambient Cut-Off	45F08	•	•	•
Compressor Sound Cover	69J03	•	•	•
Freezestat	3/8 in. tubing	93G35	•	•
	5/8 in. tubing	50A93	•	•
Hail Guards		92M89	•	
		92M90		•
		27W36		•
High Pressure Switch Kit	94J46	•	•	•
Loss of Charge Kit	84M23	•	•	•
⁵ Low Ambient Kit (down to 30°F)	27J00	•	•	•
Low Ambient Control Option (down to 0°F)		See Page 3	See Page 3	See Page 3
Mild Weather Kit	33M07	•	•	•
Monitor Kit - Service Light	76F53	•	•	•
Mounting Base		69J06	•	
		69J07		•
Outdoor Thermostat Kit	Thermostat	56A87	•	•
	Mtg. Box - US	31461	•	•
	Mtg. Box - Canada	33A09	•	•
Refrigerant Line Sets	L15-65-30, L15-65-40, or L15-65-50 Field Fabricate	•	•	•
Time Delay Relay Kit	58M81	•	•	•
Unit Stand-Off Kit	94J45	•	•	•

NOTE - Extremes of operating range are plus 10% and minus 5% of line voltage.

¹ Sound Rating Number rated in accordance with test conditions included in ARI Standard 270.

² Refrigerant charge sufficient for 15 ft. (4.6 m) length of refrigerant lines.

³ HACR type circuit breaker or fuse.

⁴ Refer to National or Canadian Electrical Code manual to determine wire, fuse and disconnect size requirements.

⁵ Freezestat is recommended with Low Ambient Kit.

LOW AMBIENT CONTROL Option (Down to 0°F)**Order one each: Speed Control Kit, Weatherproof Kit, Outdoor Fan Motor and Capacitor**

		Model No.	TPA036S2	TPA048S2	TPA060S2
Speed Control Kit		43N88	•	•	•
Weatherproof Kit		56N41	•	•	•
Outdoor Fan Motor	1/3 HP - 230V	69H73		•	•
	460V	69H74		•	•
	1/2 HP - 230V	69H75	•		
	460V	69H76	•		
Capacitor	mounting bracket (furnished)	53H06	•		
	mounting bracket (required - see below)	53H32		•	•
	Mounting Bracket (for 53H32)	15F39		•	•

I - UNIT COMPONENTS

Unit components are illustrated in figure 1.

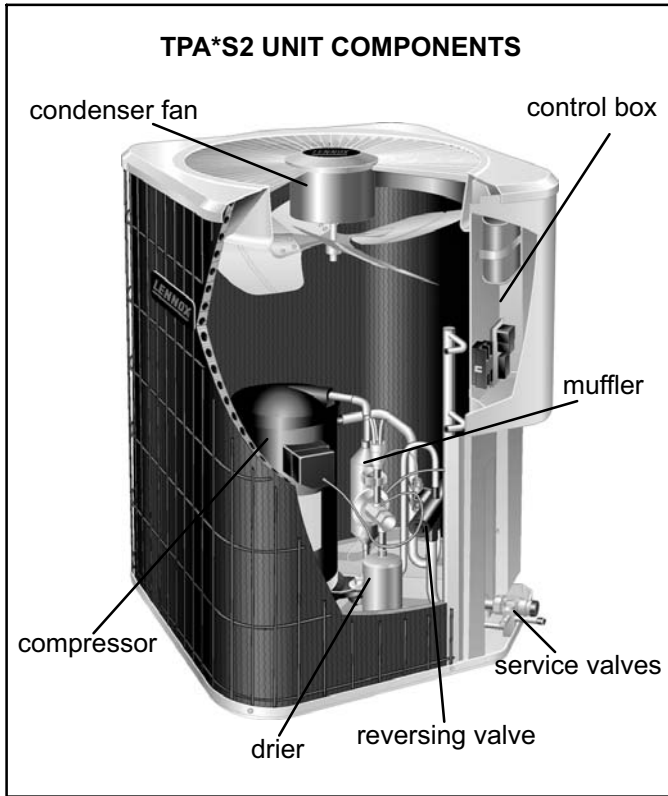

FIGURE 1

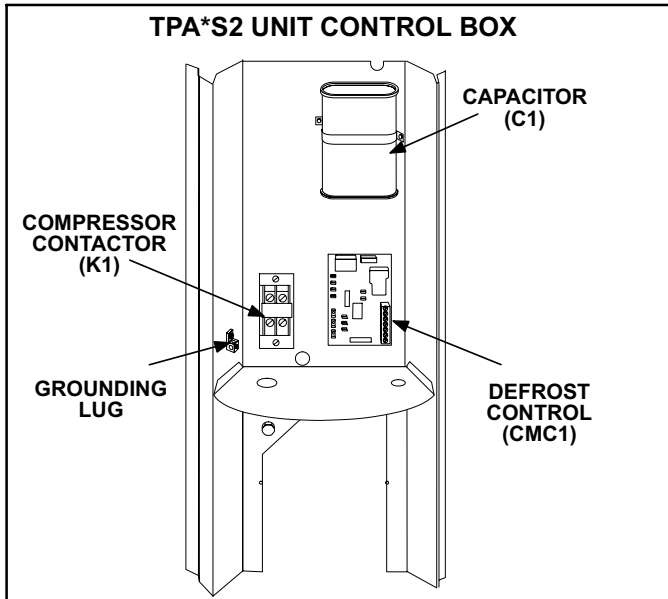

FIGURE 2

A - Control Box (Figure 2)

TPA*S2 units are not equipped with a 24V transformer. All 24 VAC controls are powered by the indoor unit. Refer to wiring diagram.

Electrical openings are provided under the control box cover. Field thermostat wiring is made to a 24V terminal strip located on the defrost control board located in the control box. See figure 3.

24V THERMOSTAT TERMINAL STRIP

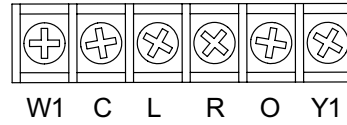

FIGURE 3

1 - Compressor Contactor K1

The compressor is energized by a contactor located in the control box. See figure 2. Three-pole contactors are used in TPA*S2 series units. K1 is energized through the control board by the indoor thermostat terminal Y1 (24V) when thermostat demand is present.

⚠ DANGER



Electric Shock Hazard.
May cause injury or death.

Disconnect all remote electrical power supplies before opening unit panel. Unit may have multiple power supplies.

2 - Capacitor C1

All units use single-phase PSC outdoor fan motors which require a run capacitor. Ratings for capacitor will be on fan motor nameplate. C1 aids in the start up of outdoor fan B4.

3 - Defrost System

The TPA*S2 defrost system includes two components: a defrost thermostat and a defrost control.

Defrost Thermostat

The defrost thermostat is located on the liquid line between the check/expansion valve and the distributor. When defrost thermostat senses 42°F (5.5°C) or cooler, the thermostat contacts close and send a signal to the defrost control board to start the defrost timing. It also terminates defrost when the liquid line warms up to 70°F (21°C).

Defrost Control

The defrost control board includes the combined functions of a time/temperature defrost control, defrost relay, diagnostic LEDs and terminal strip for field wiring connections. See figure 4.

The control provides automatic switching from normal heating operation to defrost mode and back. During compressor cycle (call for defrost), the control accumulates compressor run times at 30-, 60-, or 90-minute field-adjustable intervals. If the defrost thermostat is closed when the selected compressor run time interval ends, the defrost relay is energized and defrost begins.

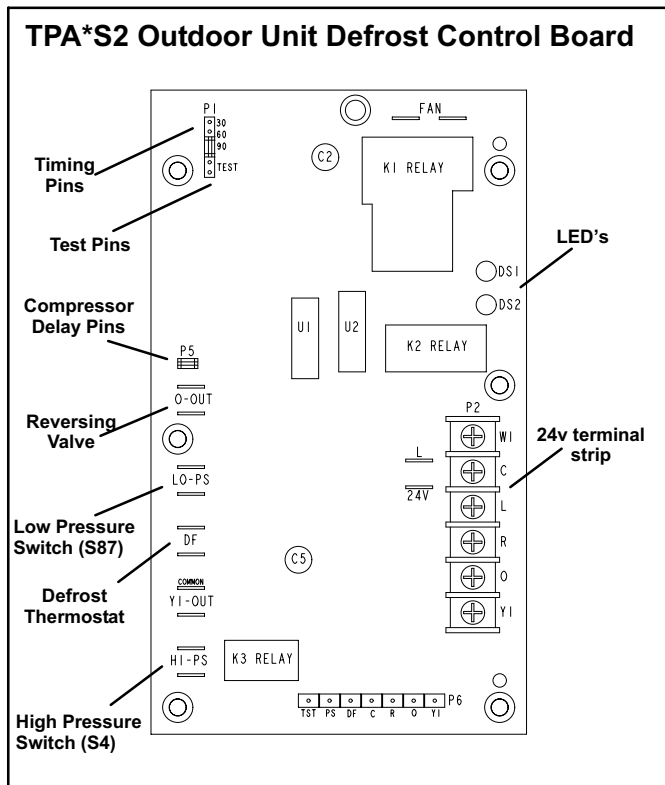

FIGURE 4

Defrost Control Timing Pins

Each timing pin selection provides a different accumulated compressor run time period for one defrost cycle. This time period must occur before a defrost cycle is initiated. The defrost interval can be adjusted to 30 (T1), 60 (T2), or 90 (T3) minutes (see figure 4). The defrost timing jumper is factory-installed to provide a 90-minute defrost interval. If the timing selector jumper is not in place, the control defaults to a 90-minute defrost interval. The maximum defrost period is 14 minutes and cannot be adjusted.

A TEST option is provided for troubleshooting. **The TEST mode may be started any time the unit is in the heating mode and the defrost thermostat is closed or jumpered.** If the jumper is in the TEST position at power-up, the control will ignore the test pins. When the jumper is placed across the TEST pins for two seconds, the control will enter the defrost mode. If the jumper is removed before an additional 5-second period has elapsed (7 seconds total), the unit will remain in defrost mode until the defrost thermostat opens or 14 minutes have passed. If the jumper is not removed until after the additional 5-second period has elapsed, the defrost will terminate and the test option will not function again until the jumper is removed and re-applied.

Compressor Delay

The defrost board has a field-selectable function to reduce occasional sounds that may occur while the unit is cycling in and out of the defrost mode. The compressor will be cycled off for 30 seconds going in and out of the defrost mode when the compressor delay jumper is removed.

NOTE - The 30-second "off" cycle is not functional when jumpering the TEST pins.

Time Delay

The timed-off delay is five minutes long. The delay helps to protect the compressor from short-cycling in case the power to the unit is interrupted or a pressure switch opens. The delay is bypassed by placing the timer select jumper across the TEST pins for 0.5 seconds.

Pressure Switch Circuit

The defrost control incorporates two pressure switch circuits. The optional high pressure switch (S4) connects to the board's HI PS terminals. The board also includes connections for an optional low pressure, or loss-of-charge-pressure, switch (S87). See figure 4 for switch terminal location.

During a single demand cycle, the defrost control will lock out the unit after the fifth time that the circuit is interrupted by any pressure switch wired to the control board. In addition, the diagnostic LEDs will indicate a locked-out pressure switch after the fifth occurrence of an open pressure switch (see Table 1). The unit will remain locked out until power to the board is interrupted, then re-established or until the jumper is applied to the TEST pins for 0.5 seconds.

NOTE - The defrost control board ignores input from the low-pressure switch terminals as follows:

- during the TEST mode,
- during the defrost cycle,
- during the 90-second start-up period,
- and for the first 90 seconds each time the reversing valve switches heat/cool modes. **If the TEST pins are jumpered and the 5-minute delay is being bypassed, the LO PS terminal signal is not ignored during the 90-second start-up period.**

Diagnostic LEDs

The defrost board uses two LEDs for diagnostics. The LEDs flash a specific sequence according to the condition.

TABLE 1

Defrost Control Board Diagnostic LED		
Mode	Green LED (DS2)	Red LED (DS1)
No power to control	OFF	OFF
Normal operation / power to control	Simultaneous Slow FLASH	
Anti-short cycle lock-out	Alternating Slow FLASH	
Low pressure switch fault (Optional)	OFF	Slow FLASH
Low pressure switch lockout (Optional)	OFF	ON
High pressure switch fault (Optional)	Slow FLASH	OFF
High pressure switch lockout (Optional)	ON	OFF

B - Compressor

All TPA*S2 units utilize a scroll compressor. The scroll compressor design is simple, efficient and requires few moving parts. A cutaway diagram of the scroll compressor is shown in figure 5. The scrolls are located in the top of the compressor can and the motor is located just below. The oil level is immediately below the motor.

The scroll is a simple compression concept centered around the unique spiral shape of the scroll and its inherent properties. Figure 6 shows the basic scroll form. Two identical scrolls are mated together forming concentric spiral shapes (figure 7). One scroll remains stationary, while the other is allowed to "orbit" (figure 8). Note that the orbiting scroll does not rotate or turn but merely orbits the stationary scroll.

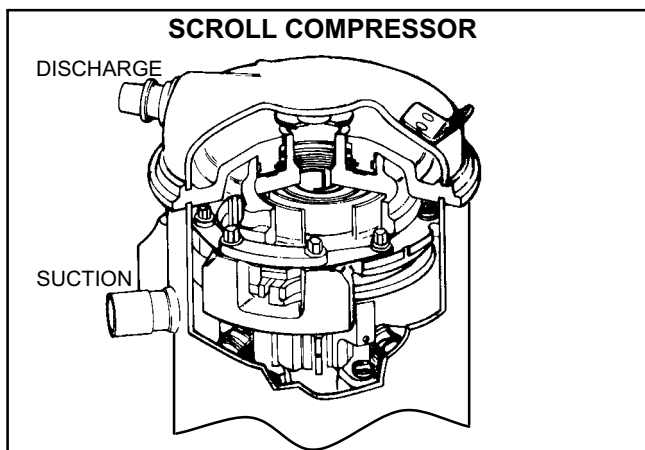

FIGURE 5

NOTE - During operation, the head of a scroll compressor may be hot since it is in constant contact with discharge gas.

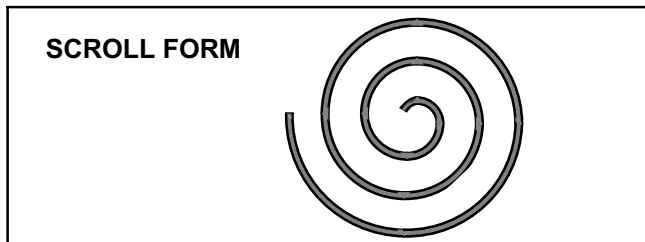

FIGURE 6

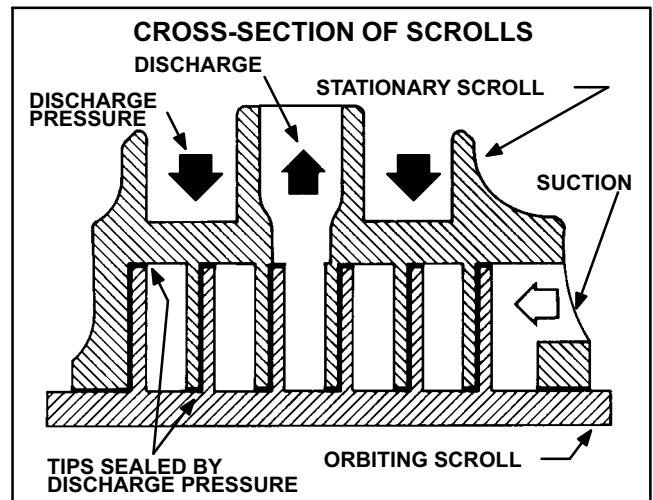

FIGURE 7

The counterclockwise orbiting scroll draws gas into the outer crescent shaped gas pocket created by the two scrolls (figure 8 - 1). The centrifugal action of the orbiting scroll seals off the flanks of the scrolls (figure 8 - 2). As the orbiting motion continues, the gas is forced toward the center of the scroll and the gas pocket becomes compressed (figure 8 - 3). When the compressed gas reaches the center, it is discharged vertically into a chamber and discharge port in the top of the compressor (figure 7). The discharge pressure forcing down on the top scroll helps seal off the upper and lower edges (tips) of the scrolls (figure 7). During a single orbit, several pockets of gas are compressed simultaneously providing smooth continuous compression.

The scroll compressor is tolerant to the effects of liquid return. If liquid enters the scrolls, the orbiting scroll is allowed to separate from the stationary scroll. The liquid is worked toward the center of the scroll and is discharged. If the compressor is replaced, conventional Lennox cleanup practices must be used. Due to its efficiency, the scroll compressor is capable of drawing a much deeper vacuum than reciprocating compressors. Deep vacuum operation can cause internal fusite arcing resulting in damaged internal parts and will result in compressor failure. Never use a scroll compressor for evacuating or "pumping-down" the system. This type of damage can be detected and will result in denial of warranty claims.

The scroll compressor is quieter than a reciprocating compressor, however, the two compressors have much different sound characteristics. The sounds made by a scroll compressor do not affect system reliability, performance, or indicate damage.

See compressor nameplate and ELECTRICAL DATA table on page 2 for compressor specifications.

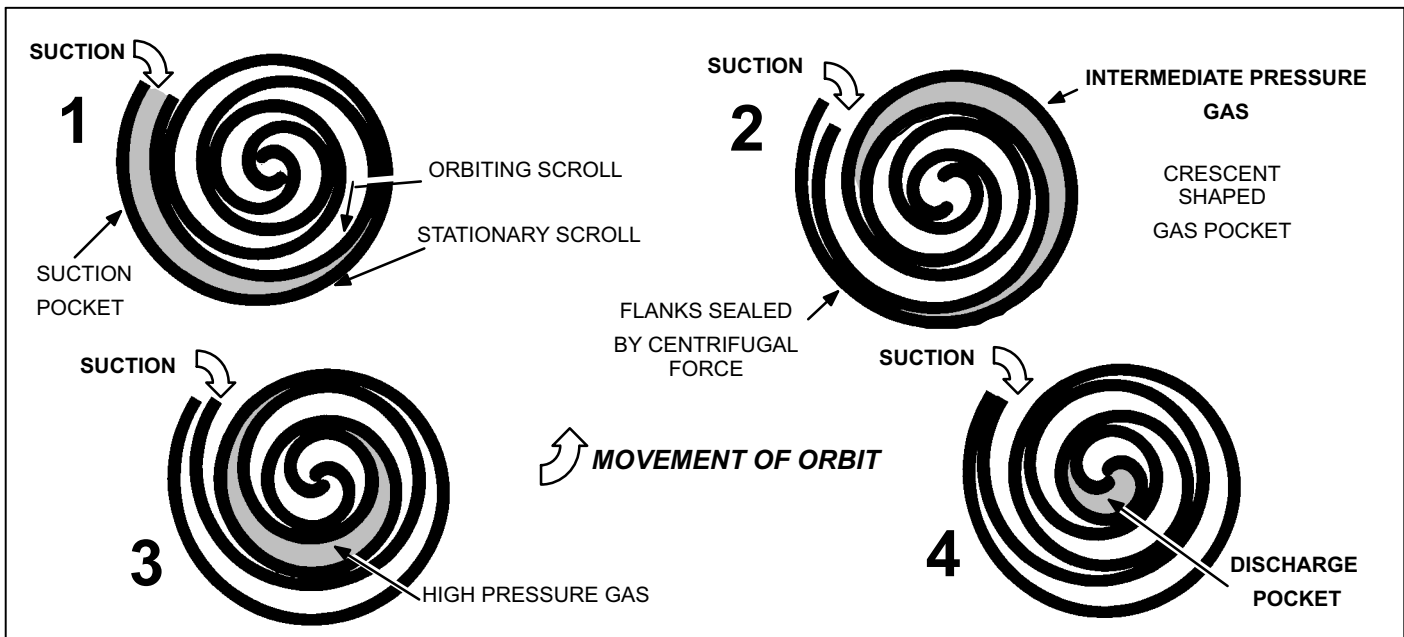

FIGURE 8

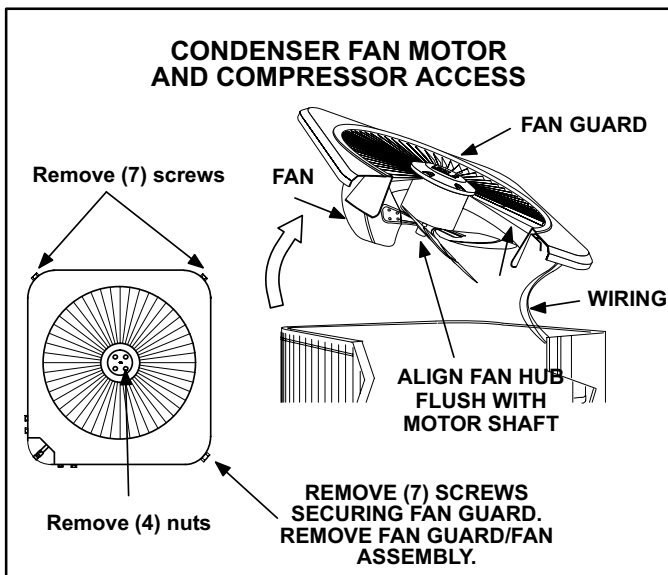

FIGURE 9

⚠ DANGER

Make sure all power is disconnected before beginning electrical service procedures.

C - Outdoor Fan Motor B4

All units use single-phase PSC fan motors. In all units, the condenser fan is controlled by the compressor contactor (and defrost control during defrost cycles).

ELECTRICAL DATA tables in this manual show specifications for condenser fans used in TPA*S2s.

Access to the condenser fan motor on all units is gained by removing the seven screws securing the fan assembly. See figure 9. The outdoor fan motor is removed from the fan guard by removing the four nuts found on the top panel. If outdoor fan motor must be replaced, align fan hub flush with motor shaft. Drip loops should be used in wiring when servicing motor.

D - Reversing Valve L1 and Solenoid

A refrigerant reversing valve with electromechanical solenoid is used to reverse refrigerant flow during unit operation. The reversing valve requires no maintenance. The only replaceable part is the solenoid. If the reversing valve itself has failed, it must be replaced.

If replacement is necessary, access reversing valve by removing the outdoor fan motor. Refer to figure 9.

E - Crankcase Heater HR1 & Thermostat S40 (option)

Crankcase heater HR1 prevents liquid from accumulating in the compressor. HR1 is controlled by crankcase heater thermostat S40, located on the liquid line. When liquid line temperature drops below 50° F, S40 closes energizing HR1. S40 opens when liquid line temperature reaches 70°.

F - High Pressure Switch S4 (option)

S4 is a manual re-set switch located on the liquid line. When liquid line pressure rises above the factory setting of 410 ± 10 psi, the switch opens and shuts off the compressor.

G - Low Pressure Switch S87 (option)

S87 is an auto-reset low pressure switch located on the suction line. The switch shuts off the compressor when suction pressure drops below the factory setting. The switch is ignored during the first 90 seconds of compressor start up, during defrost operation, 90 seconds after defrost operation, during test mode and when the outdoor temperature drops below 15° F. The switch is factory set to open at 25 ± 5 psig and close at 55 ± 5 psig. These settings are not adjustable.

II - REFRIGERANT SYSTEM

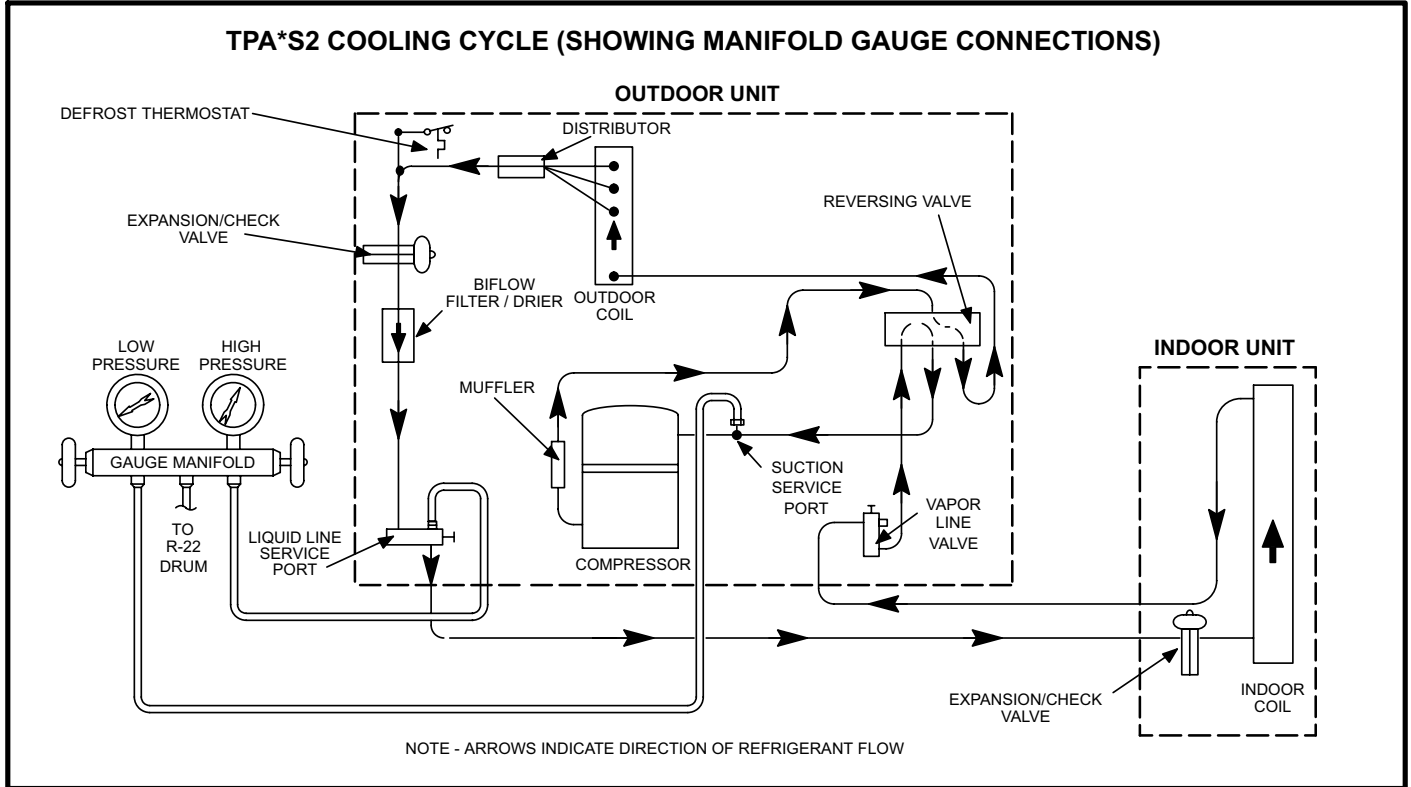

FIGURE 10

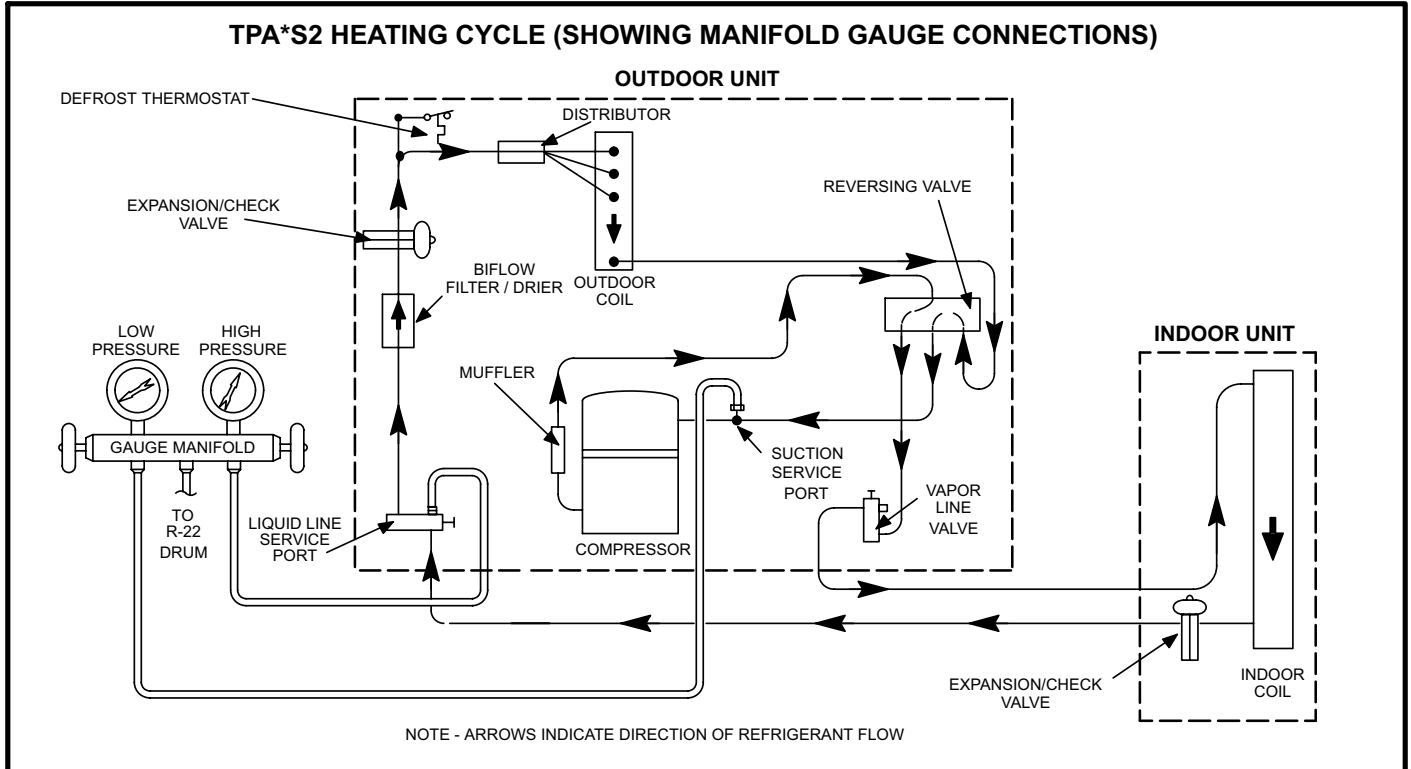

FIGURE 11

A - Plumbing

Field refrigerant piping consists of liquid and vapor lines from the outdoor unit (sweat connections). Use Lennox L15 (sweat) series line sets as shown in table 2.

TABLE 2

Refrigerant Line Sets					
Model	Field Connections		Recommended Line Set		
	Liquid Line	Vapor Line	Liquid Line	Vapor Line	L15 Line Sets
-036 -048	3/8 in. (10 mm)	7/8 in. (22 mm)	3/8 in. (10 mm)	7/8 in. (22 mm)	L15-65 15 ft. - 50 ft. (4.6 m - 15 m)
-060	3/8 in. (10 mm)	1-1/8 in. (29 mm)	3/8 in. (10 mm)	1-1/8 in. (29 mm)	Field Fabricated

B - Service Valves

⚠ IMPORTANT

Only use Allen wrenches of sufficient hardness (50Rc - Rockwell Harness Scale min). Fully insert the wrench into the valve stem recess. Service valve stems are factory torqued (from 9 ft lbs for small valves, to 25 ft lbs for large valves) to prevent refrigerant loss during shipping and handling. Using an Allen wrench rated at less than 50Rc risks rounding or breaking off the wrench, or stripping the valve stem recess.

The liquid and vapor line service valves (figures 12 and 13) and gauge ports are accessible from outside the unit.

Each valve is equipped with a service port. The service ports are used for leak testing, evacuating, charging and checking charge. A schrader valve is factory installed. A service port cap is supplied to protect the schrader valve from contamination and serve as the primary leak seal.

NOTE-Always keep valve stem caps clean.

To Access Schrader Port:

- 1 - Remove service port cap with an adjustable wrench.
- 2 - Connect gauge to the service port.
- 3 - When testing is completed, replace service port cap. Tighten finger tight, then an additional 1/6 turn.

To Open Liquid or Vapor Line Service Valve:

- 1 - Remove stem cap with an adjustable wrench.
- 2 - Using service wrench and hex head extension (5/16 for vapor line and 3/16 for liquid line), back the stem out counterclockwise until the valve stem just touches the retaining ring.
- 3 - Replace stem cap and tighten finger tight, then tighten an additional 1/6 turn.

⚠ DANGER

Do not attempt to backseat this valve. Attempts to backseat this valve will cause snap ring to explode from valve body under pressure of refrigerant. Personal injury and unit damage will result.

To Close Liquid or Vapor Line Service Valve:

- 1 - Remove stem cap with an adjustable wrench.
- 2 - Using service wrench and hex head extension (5/16 for vapor line and 3/16 for liquid line), turn stem clockwise to seat the valve. Tighten firmly.
- 3 - Replace stem cap. Tighten finger tight, then tighten an additional 1/6 turn.

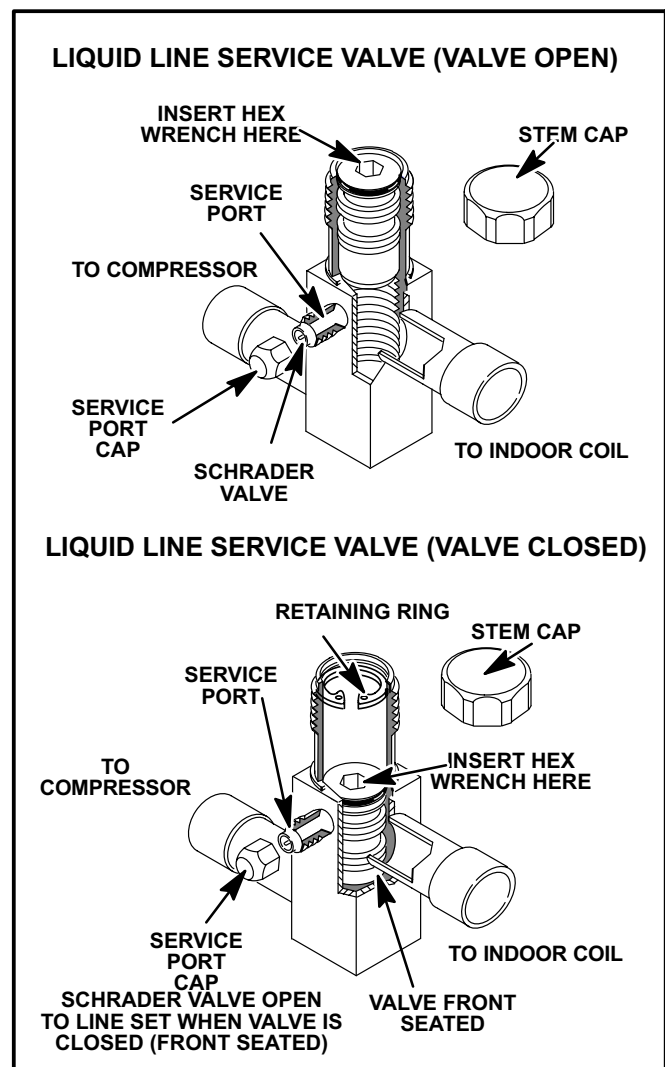

FIGURE 12

Vapor Line (Ball Type) Service Valve 5 ton unit only

A ball-type full service valve is used on TPA*S2060 units only. Valves are not rebuildable. If a valve has failed it must be replaced. A ball valve is illustrated in figure 13.

The ball valve is equipped with a service port. A schrader valve is factory installed. A service port cap is supplied to protect the schrader valve from contamination and assure a leak free seal.

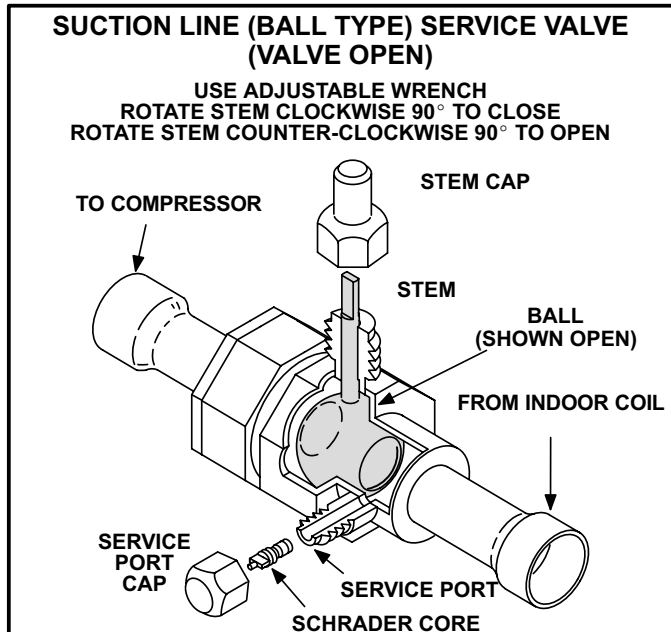

FIGURE 13

III - CHARGING

A - Pumping Down System

⚠ CAUTION

Deep vacuum operation (operating compressor at 0 psig or lower) can cause internal fusite arcing resulting in a damaged or failed compressor. This type of damage will result in denial of warranty claim.

The system may be pumped down when leak checking the line set and indoor coil or making repairs to the line set or indoor coil.

- 1- Attach gauge manifold.
- 2- Front seat (close) liquid line valve.
- 3- Start outdoor unit.
- 4- Monitor suction gauge. Stop unit when 0 psig is reached.
- 5- Front seat (close) suction line valve.

B - Leak Testing (To Be Done Before Evacuating)

- 1- Attach gauge manifold and connect a drum of dry nitrogen to center port of gauge manifold.
- 2- Open high pressure valve on gauge manifold and pressurize line set and indoor coil to 150 psig (1034 kPa).
- 3- Check lines and connections for leaks.

NOTE-The preferred method is to use an electronic leak or Halide detector. Add a small amount of R-22 (3 to 5 psig [20kPa to 34kPa]) then pressurize with nitrogen to 150 psig.

- 4- Release nitrogen pressure from the system, correct any leaks and recheck.

⚠ WARNING



Fire, Explosion and Personal Safety Hazard.

Failure to follow this warning could result in damage, personal injury or death.

Never use oxygen to pressurize or purge refrigeration lines. Oxygen, when exposed to a spark or open flame, can cause damage by fire and / or an explosion, that can result in personal injury or death.

⚠ WARNING



Danger of explosion!

When using a high pressure gas such as dry nitrogen to pressurize a refrigerant or air conditioning system, use a regulator that can control the pressure down to 1 or 2 psig (6.9 to 13.8 kPa).

C - Evacuating the System

- 1- Attach gauge manifold. Connect vacuum pump (with vacuum gauge) to center port of gauge manifold. With both manifold service valves open, start pump and evacuate indoor coil and refrigerant lines.

⚠ IMPORTANT

A temperature vacuum gauge, mercury vacuum (U-tube), or thermocouple gauge should be used. The usual Bourdon tube gauges are not accurate enough in the vacuum range.

⚠ IMPORTANT

The compressor should never be used to evacuate a refrigeration or air conditioning system.

- 2- Evacuate the system to 29 inches (737mm) vacuum. During the early stages of evacuation, it is desirable to stop the vacuum pump at least once to determine if there is a rapid loss of vacuum. A rapid loss of vacuum would indicate a leak in the system and a repeat of the leak testing section would be necessary.
- 3- After system has been evacuated to 29 inches (737mm), close gauge manifold valves to center port, stop vacuum pump and disconnect from gauge manifold. Attach an upright nitrogen drum to center port of gauge manifold and open drum valve slightly to purge line at manifold. Break vacuum in system with nitrogen pressure by opening manifold high pressure valve. Close manifold high pressure valve to center port.
- 4- Close nitrogen drum valve and disconnect from gauge manifold center port. Release nitrogen pressure from system.
- 5- Connect vacuum pump to gauge manifold center port. Evacuate system through manifold service valves until vacuum in system does not rise above .5mm of mercury absolute pressure or 500 microns within a 20-minute period after stopping vacuum pump.
- 6- After evacuation is complete, close manifold center port, and connect refrigerant drum. Pressurize system slightly with refrigerant to break vacuum.

D - Charging

The outdoor unit should be charged during warm weather. However, applications arise in which charging must occur in the colder months. *The method of charging is determined by the unit's refrigerant metering device and the outdoor ambient temperature.*

Measure the liquid line temperature and the outdoor ambient temperature as outlined below:

- 1.. Close manifold gauge set valves. Connect the manifold gauge set to the service valves.
 - low pressure gauge to *vapor* valve service port
 - high pressure gauge to *liquid* valve service port
- 2.. Connect the center manifold hose to an upright cylinder of HCFC-22.
- 3.. Set the room thermostat to call for heat. This will create the necessary load for properly charging the system in the cooling cycle.
- 4.. Use a digital thermometer to record the outdoor ambient temperature.
- 5.. When the heating demand has been satisfied, switch the thermostat to cooling mode with a set point of 68°F (20°C). When pressures have stabilized, use a digital thermometer to record the liquid line temperature.
- 6.. The outdoor temperature will determine which charging method to use. Proceed with the appropriate charging procedure.

Charge using the Weigh-In Method - Outdoor Temperature < 65°F (18°C)

If the system is void of refrigerant, or if the outdoor ambient temperature is cool, first, locate and repair any leaks and then weigh in the refrigerant charge into the unit.

- 1.. Recover the refrigerant from the unit.
- 2.. Conduct leak check; evacuate as previously outlined.
- 3.. Weigh in the unit nameplate charge. If weighing facilities are not available or if charging the unit during warm weather, use one of the following procedures.

Charge using the Subcooling Method - Outdoor Temperature < 65°F (18°C)

When the outdoor ambient temperature is below 65°F (18°C), use the subcooling method to charge the unit. It may be necessary to restrict the air flow through the outdoor coil to achieve pressures in the 200-250 psig (1379-1724 kPa) range. These higher pressures are necessary for checking the charge. Block equal sections of air intake panels and move obstructions sideways until the liquid pressure is in the 200-250 psig (1379-1724 kPa) range. See figure 14.

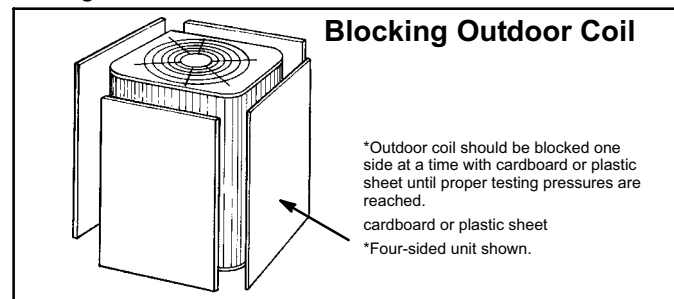

FIGURE 14

- 1.. With the manifold gauge hose still on the liquid service port and the unit's pressure stabilized, use a digital thermometer to record the liquid line temperature.
- 2.. At the same time, record the liquid line pressure reading.
- 3.. Use a temperature/pressure chart for HCFC-22 to determine the saturation temperature for the liquid line pressure reading.
- 4.. Subtract the liquid line temperature from the saturation temperature (according to the chart) to determine subcooling.
- 5.. Compare the subcooling value results with those in table 3. If subcooling is greater than shown, recover some refrigerant. If subcooling is less than shown, add some refrigerant.

TABLE 3

TPA*S2 Subcooling Values			
—	°	Saturation Temperature °F (°C)	
—	°	Liquid Line Temperature °F (°C)	
=	°	Subcooling Value °F (°C)	
Model	TPA*S2036	TPA*S2048	TPA*S2060
°F (°C)*	6 (3.3)	4 (2.2)	9 (5)
NOTE - For best results, use the same electronic thermometer to check both outdoor-ambient and liquid-line temperatures. *F: +/-1.0°; C: +/-0.5°			

V - WIRING DIAGRAM AND SEQUENCE OF OPERATION

TPA*S2 230 VOLT UNIT DIAGRAM

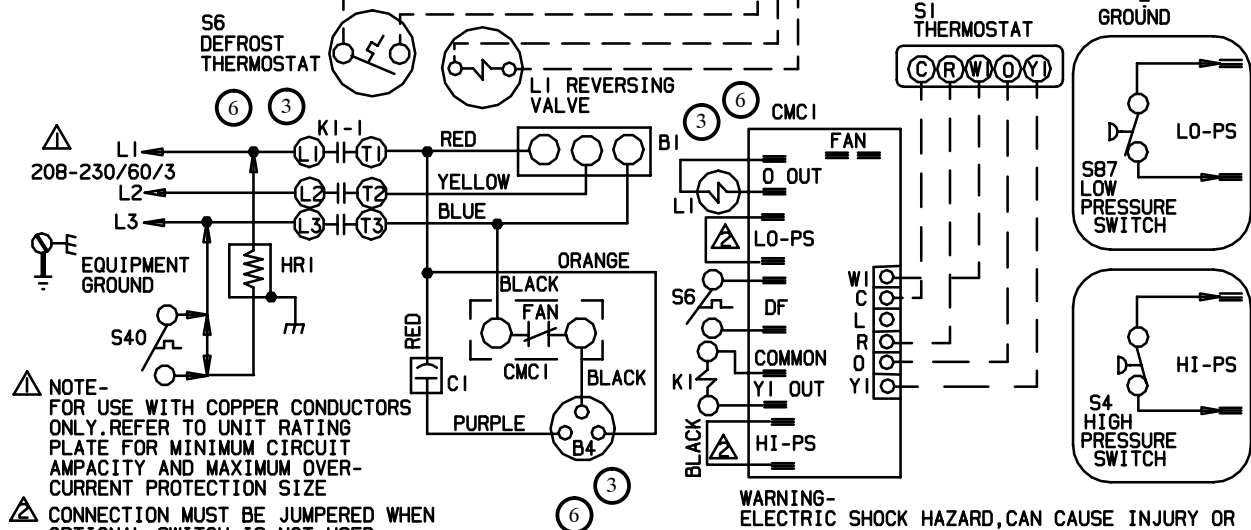
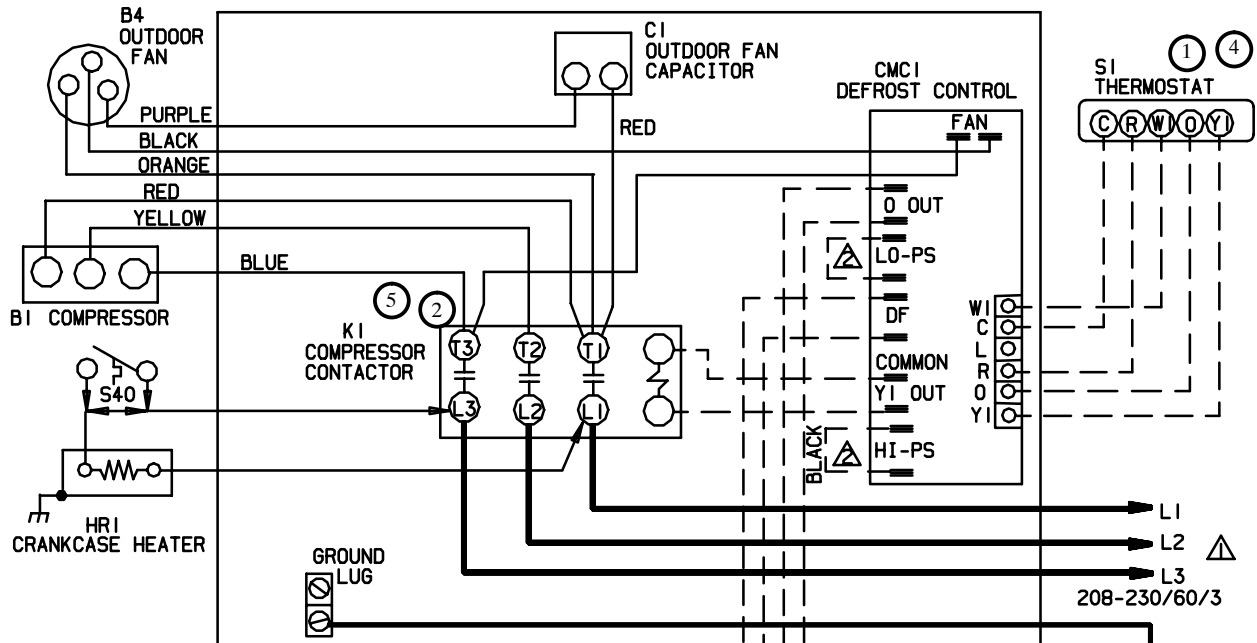

NOTE-
FOR USE WITH COPPER CONDUCTORS
ONLY. REFER TO UNIT RATING
PLATE FOR MINIMUM CIRCUIT
AMPACITY AND MAXIMUM OVER-
CURRENT PROTECTION SIZE

CONNECTION MUST BE JUMPERED WHEN
OPTIONAL SWITCH IS NOT USED

KEY	DESCRIPTION
B1	COMPRESSOR
B4	MOTOR-OUTDOOR FAN
C1	CAPACITOR-OUTDOOR FAN
CMC1	CONTROL-DEFROST
HRI	HEATER-COMPRESSOR
K1, -I	CONTACTOR-COMPRESSOR
L1	VALVE-REVERSING
S4	SWITCH-HIGH PRESSURE
S6	SWITCH-DEFROST
S40	THERMOSTAT-CRANKCASE
S87	SWITCH-LOW PRESSURE

WARNING-
ELECTRIC SHOCK HAZARD, CAN CAUSE INJURY OR
DEATH. UNIT MUST BE GROUND IN ACCORDANCE
WITH NATIONAL AND LOCAL CODES.

← DENOTES OPTIONAL COMPONENTS
— LINE VOLTAGE FIELD INSTALLED
- - - CLASS II VOLTAGE FIELD INSTALLED

1005	Supersedes
New Form No. 535,038W	

© 2005

Litho U.S.A.

TPA*S2 460 VOLT UNIT DIAGRAM

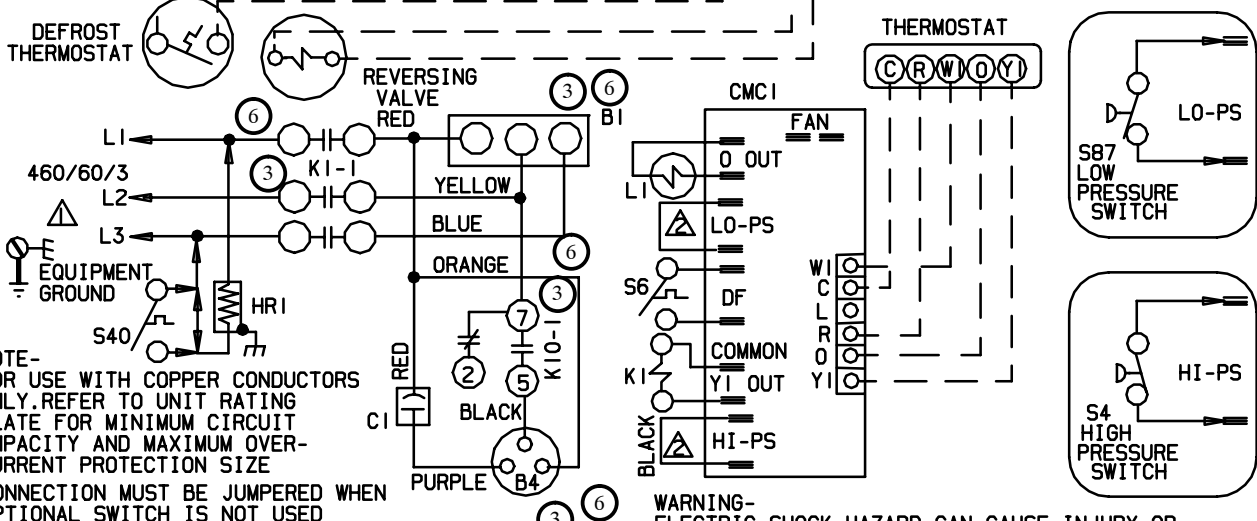
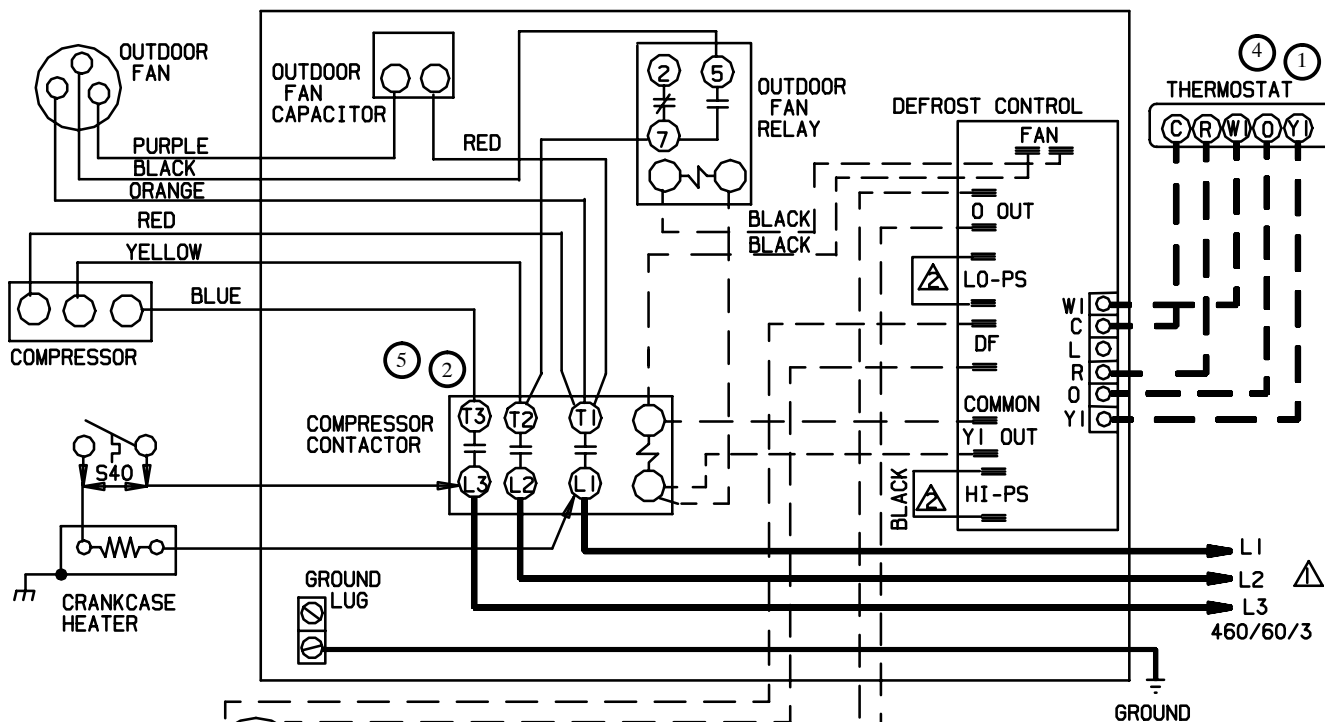

NOTE-
FOR USE WITH COPPER CONDUCTORS
ONLY. REFER TO UNIT RATING
PLATE FOR MINIMUM CIRCUIT
AMPACITY AND MAXIMUM OVER-
CURRENT PROTECTION SIZE

CONNECTION MUST BE JUMPED WHEN
OPTIONAL SWITCH IS NOT USED

KEY	DESCRIPTION
B1	COMPRESSOR
B4	MOTOR-OUTDOOR FAN
C1	CAPACITOR-OUTDOOR FAN
CMCI	CONTROL-DEFROST
HR1	HEATER-COMPRESSOR
KI,-1	CONTACTOR-COMPRESSOR
K10,-1	RELAY-OUTDOOR FAN
L1	VALVE-REVERSING
S4	SWITCH-LIMIT, HI PRESS
S6	SWITCH-DEFROST
S40	THERMOSTAT-CRANKCASE
S87	SWITCH-LOW PRESS

WARNING-
ELECTRIC SHOCK HAZARD, CAN CAUSE INJURY OR
DEATH. UNIT MUST BE GROUND IN ACCORDANCE
WITH NATIONAL AND LOCAL CODES.

← DENOTES OPTIONAL COMPONENTS
— LINE VOLTAGE FIELD INSTALLED
- - - CLASS II VOLTAGE FIELD INSTALLED

1005	Supersedes
New Form No. 535, 039W	

TPA*S2 230 and 460 Volt 1 THROUGH 5 TON OPERATING SEQUENCE

This is the sequence of operation for TPA*S2 series units. The sequence is outlined by numbered steps which correspond to circled numbers on the adjacent diagram. The steps are identical for both cooling and first stage heating demand with the exception reversing valve L1 is energized during cooling demand and de-energized during heating demand.

NOTE- The thermostat used may be electromechanical or electronic.

NOTE- Transformer in indoor unit supplies power (24 VAC) to the thermostat and outdoor unit controls.

COOLING:

Internal thermostat wiring energizes terminal O by cooling mode selection, energizing the reversing valve L1.

Demand initiates at Y1 in the thermostat.

24VAC energizes compressor contactor K1.

K1-1 N.O. closes, energizing compressor (B1) and outdoor fan motor (B4).

460 VOLT UNITS - K1-1 N.O. closes, energizing compressor (B1) and outdoor fan relay K10. K10-1 closes energizing outdoor fan motor (B4).

END OF COOLING DEMAND:

Demand is satisfied. Terminal Y1 is de-energized.

Compressor contactor K1 is de-energized.

K1-1 opens and compressor (B1) and outdoor fan motor (B4) are de-energized and stop immediately.

460 VOLT UNITS - K1-1 opens and compressor (B1) and outdoor fan relay K10 is de-energized. K10-1 opens and de-energizes outdoor fan motor (B4).

FIRST STAGE HEAT:

Internal thermostat wiring de-energizes terminal O by heating mode selection, de-energizing the reversing valve L1.

See steps 1, 2 and 3.

End of FIRST STAGE HEAT:

See steps 4, 5 and 6.

DEFROST MODE:

During heating operation when outdoor coil temperature drops below 35°F (2°C) or 42°F (5.5°C) defrost switch (thermostat) S6 closes.

Defrost control CMC1 begins timing. If defrost thermostat (S6) remains closed at the end of the 30, 60 or 90 minute period, defrost relay energizes and defrost begins.

During defrost CMC1 energizes the reversing valve and W1 on the terminal strip (operating indoor unit on the first stage heat mode), while de-energizing outdoor fan motor B4.

Defrost continues 14 ± 1 minutes or until thermostat switch (S6) opens. When defrost thermostat opens, defrost control timer loses power and resets.

When CMC1 resets, the reversing valve and W1 on the terminal strip are de-energized, while the outdoor fan motor B4 is energized.

When CMC1 resets, the reversing valve and W1 on the terminal strip are de-energized, while the outdoor fan motor B4 is energized.