



Dave Lennox Signature® Collection
XPG15 Units

⚠ WARNING

Improper installation, adjustment, alteration, service or maintenance can cause personal injury, loss of life, or damage to property.

Installation and service must be performed by a licensed professional installer (or equivalent) or a service agency.

⚠ IMPORTANT

The Clean Air Act of 1990 bans the intentional venting of refrigerant (CFCs, HCFCs AND HFCs) as of July 1, 1992. Approved methods of recovery, recycling or reclaiming must be followed. Fines and/or incarceration may be levied for noncompliance.

The XPG15 is a high efficiency residential split-system dual-fuel heat pump unit, which features a scroll compressor and HFC-410A refrigerant. XPG15 units are available in 2, 2-1/2, 3, 3-1/2, 4 and 5 ton sizes. The series is designed for use with an check expansion valve only (approved for use with HFC-410A in the indoor unit. This manual is divided into sections which discuss the major components, refrigerant system, charging procedure, maintenance and operation sequence.

The Lennox dedicated dual-fuel XPG15 outdoor unit technology allows the system to alternate between heat pump heating when outdoor temperature is ABOVE 32°F (0°C) and automatically switching over to gas furnace heating when outdoor temperature is BELOW 32°F (0°C), making the most efficient use of fuel sources.

TABLE OF CONTENTS

Specifications, Electrical Data and Optional Accessories	2
Unit Dimensions	3
Model Number Identification	3
Unit Parts Arrangement	4
Control Box Parts Arrangement	4
Scroll Compressor Operations	6
Unit Components	7
Operating Gauge Set and Service Valves	8
Recovering Refrigerant from Existing System	10
Outdoor Unit Placement	11
Removing and Installing Panels	11
New or Replacement Line Set	15
Brazing Connections	17
Flushing	20
Leak Testing	21
Evacuating	21
Electrical	23
System Setup Information	23
Servicing Unit Delivered Void of Charge	32
Unit Start-Up	32
System Charge	32
Indoor Coil Matchups	36
Operating and Temperature Pressures	37
System Operations	38
Defrost System	38
Operating Modes	46
Dealer — Maintenance	55
Sound Reduction (SR1) Cover	55

ATTENTION SERVICE TECHNICIAN

The ComfortSense 5000 and 7000 are the **ONLY room thermostats approved** by Lennox for use with the XPG15 series heat pump.

COMFORTSENSE® 5000
CATALOG# X4147

COMFORTSENSE® 7000
CATALOG# Y0349



IMPORTANT — Setup is critical to ensure proper system operation. Thermostat is not included and must be purchased separately.

System setup information and field wiring connections for both thermostat models are available starting on page 23.

Specifications, Electrical Data and Optional Accessories¹

SPECIFICATIONS

General Data		Model No.	XPG15-024	XPG15-030	XPG15-036	XPG15-042	XPG15-048	XPG15-060
Nominal Tonnage			2	2.5	3	3.5	4	5
Connections (sweat)	Liquid line (o.d.) - in.		3/8	3/8	3/8	3/8	3/8	3/8
	Vapor (Suction) line (o.d.) - in.		3/4	3/4	3/4	7/8	7/8	1-1/8
Refrigerant	¹ HFC-410A charge furnished		11 lbs. 10 oz.	11 lbs. 11 oz.	11 lbs. 0 oz.	12 lbs. 5 oz.	14 lbs. 14 oz.	15 lbs. 8 oz.
Outdoor Coil	Net face area - sq. ft.	Outer coil	20.73	20.73	20.73	20.73	27.21	27.21
		Inner coil	20.08	20.08	20.08	20.08	26.36	26.36
		Tube diameter - in.	5/16	5/16	5/16	5/16	5/16	5/16
		No. of rows	2	2	2	2	2	2
		Fins per inch	22	22	22	22	22	22
Outdoor Fan	Diameter - in.		26	26	26	26	26	26
	No. of blades		3	3	3	3	3	3
	Motor hp		1/15	1/15	1/12	1/5	1/5	1/3
	Cfm		2100	2100	2300	3700	3910	4200
	Rpm		825	825	825	825	825	825
	Watts		100	100	112	233	212	200
Shipping Data - lbs. 1 pkg.			290	292	297	323	368	372

ELECTRICAL DATA

Line voltage data - 60hz		208/230V-1ph					
² Maximum overcurrent protection (amps)		30	30	35	40	50	60
³ Minimum circuit ampacity		17.4	18.1	21.5	23.5	28.4	35.8
Compressor	Rated load amps	13.5	14.1	16.7	17.9	21.8	26.4
	Locked rotor amps	58.3	73.0	79.0	107.0	117.0	134.0
	Power factor	0.99	0.97	0.98	0.94	0.99	0.98
Outdoor Fan Motor	Full load amps	0.5	0.5	0.65	1.1	1.1	2.8
	Locked rotor amps	0.8	0.8	1.1	2.1	2.1	N/A

OPTIONAL ACCESSORIES - must be ordered extra

Compressor Hard Start Kit		88M91	•	•	•	•	•	•
Compressor Low Ambient Cut-Off		45F08	•	•	•	•	•	•
Freezestat	3/8 in. tubing	93G35	•	•	•	•	•	•
	5/8 in. tubing	50A93	•	•	•	•	•	•
Low Ambient Kit		54M89	•	•	•	•	•	•
Indoor Blower Delay Relay		58M81	•	•	•	•	•	•
Mild Weather Kit		33M07	•	•	•	•	•	•
Suction Line Drier		88K44	•	•	•	•	•	•
Replacement Liquid Line Bi-Flow Drier		95M51	•	•	•	•	•	•
Refrigerant Line Sets	L15-41-20	L15-41-40	•	•	•			
	L15-41-30	L15-41-50						
	L15-65-30	L15-65-40				•	•	
		L15-65-50						
Field Fabricate								•
Snow Shield Kit ⁵		44W14	•	•	•	•	•	•
Snow Guard Kit ⁵		X8782	•	•	•	•	•	•
Thermostats ⁴			•	•	•	•	•	•
ComfortSense® 5000		X4147	•	•	•	•	•	•
Outdoor Sensor for Y0349		X2658						
ComfortSense® 7000		Y0349						

NOTE — Extremes of operating range are plus 10% and minus 5% of line voltage.

¹ Refrigerant charge sufficient for 15 ft. (4.6 m) length of refrigerant lines.

² HACR type breaker or fuse.

³ Refer to National or Canadian Electrical Code manual to determine wire, fuse and disconnect size requirements.

⁴ These are the only thermostats approved for use with XPG15 Heat Pumps.

⁵ The XPG15 unit will be inactive below 32°F (0°C). To prevent heavy snow accumulation in the unit during these inactive periods, Lennox recommends the installation of the Snow Guard Top Cover and the Snow Shield Kit.

Unit Dimensions -- Inches (mm)²

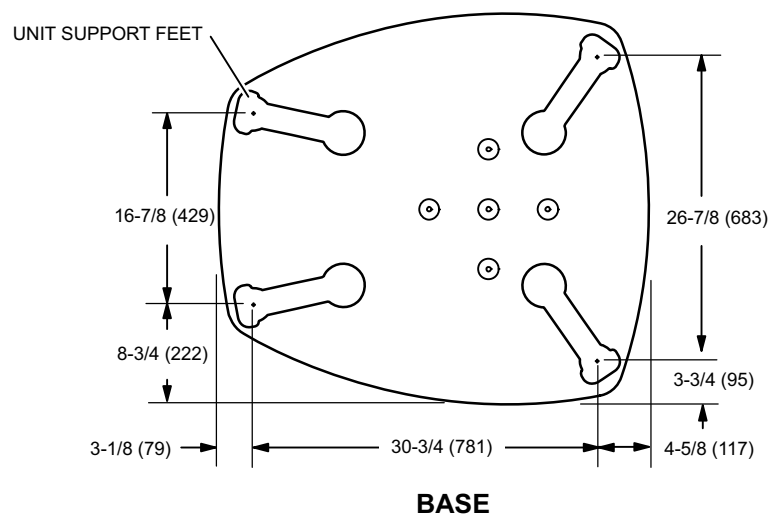
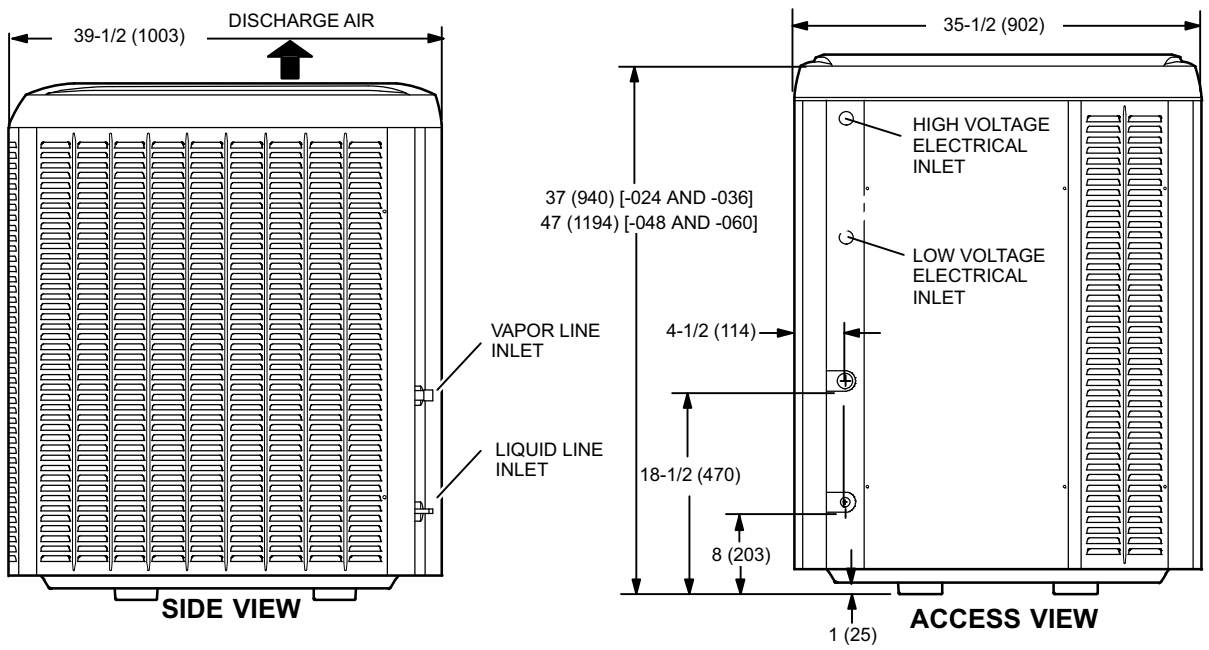

Model Number Identification³

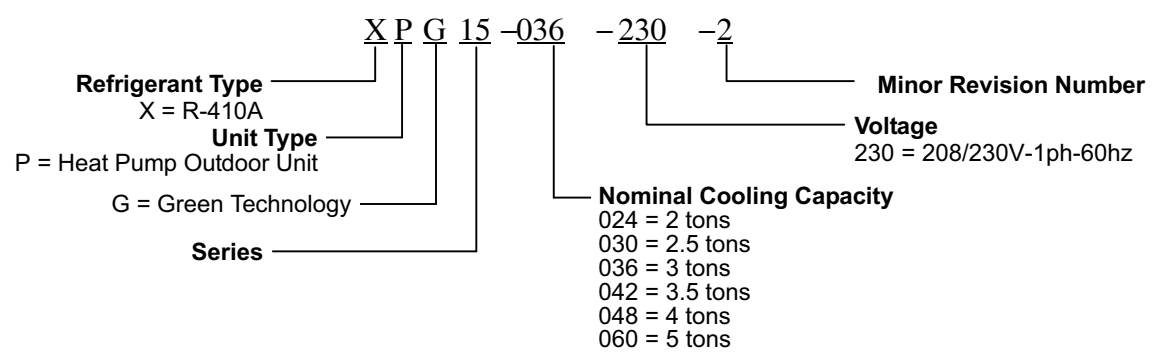

Unit Parts Arrangement4

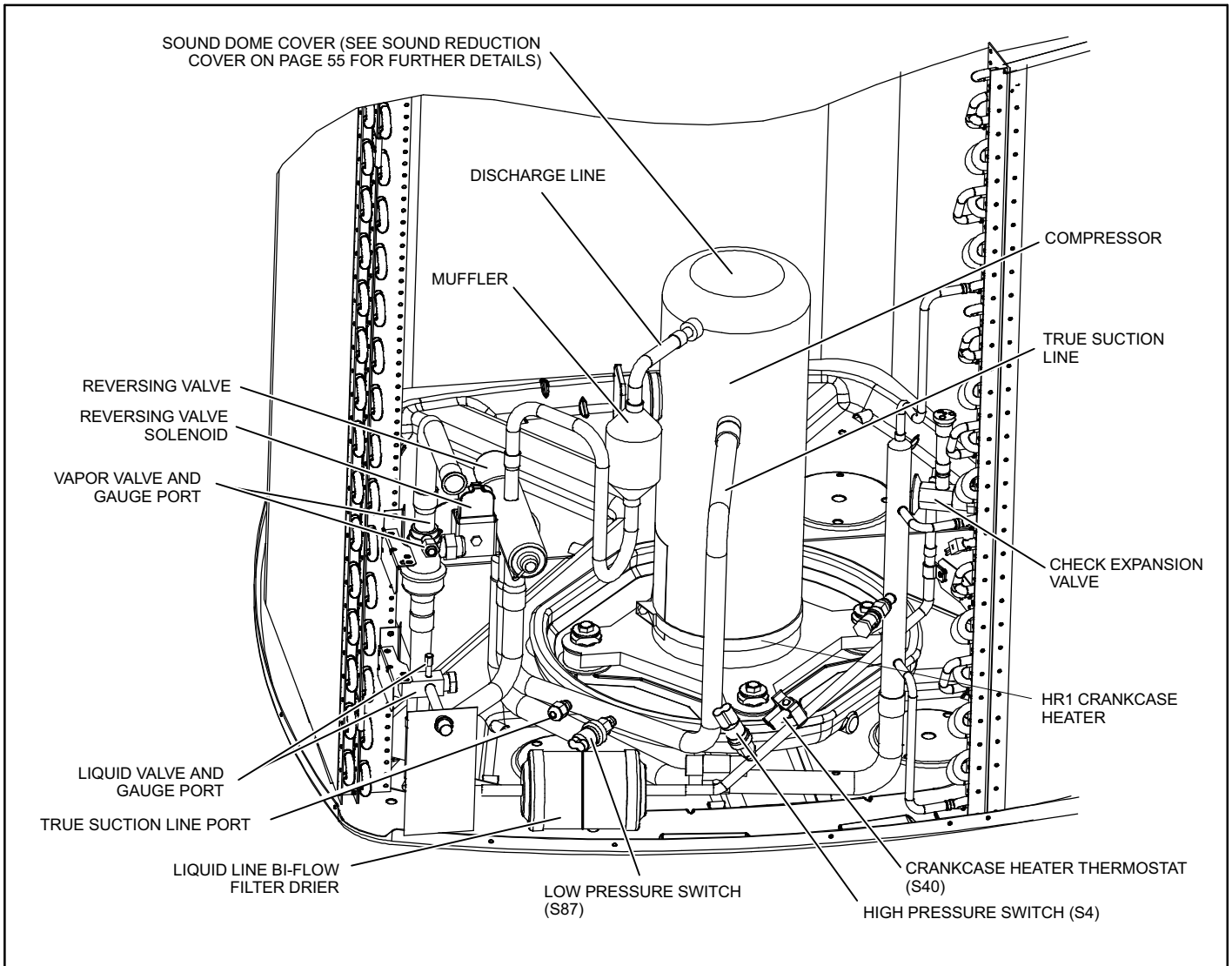

Control Panel Parts Arrangement5

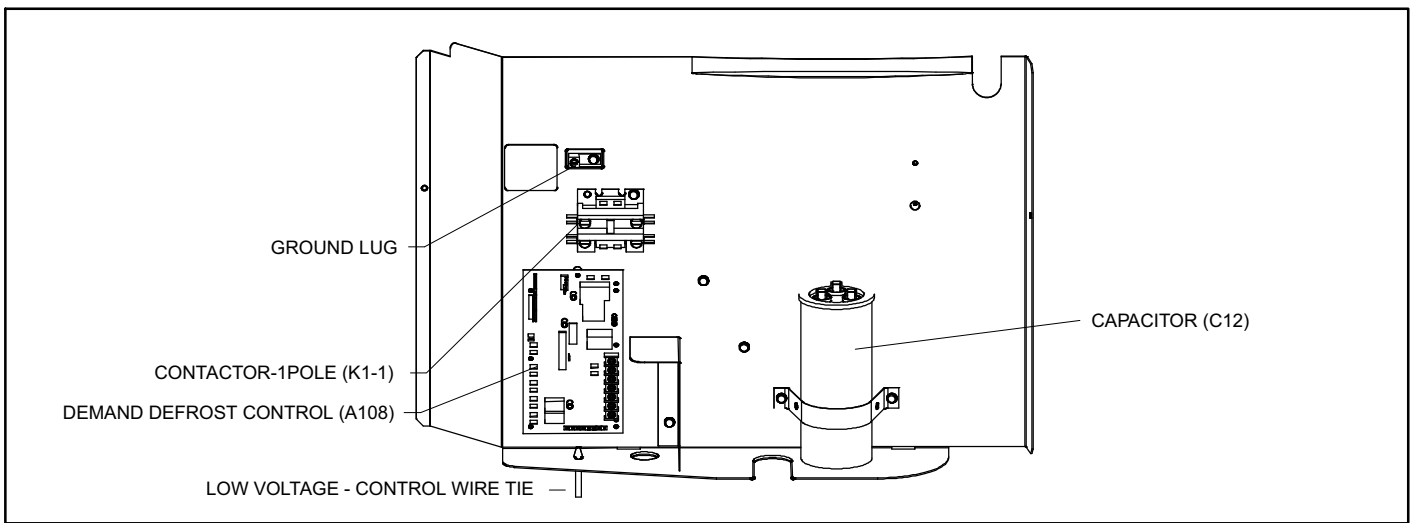

SENSOR

LOCATIONS

DETAIL A

WIRE TIE

AMBIENT SENSOR — Extend tip of plastic sensor just outside of plastic sleeve.

Place ambient sensor and wire from Demand Defrost Control inside of plastic sleeve and route through gap between corner post and coil support as shown. Secure with wire tie.

DEFROST COIL SENSOR — Clip coil temperature sensor from the Demand Defrost Control on the return bend shown on models as follows:

SLEEVE

DETAIL B

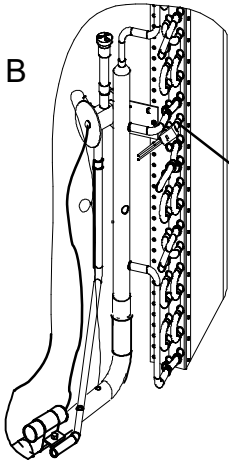

12 TUBES UP
MODELS -024, -030,
-036 AND -042

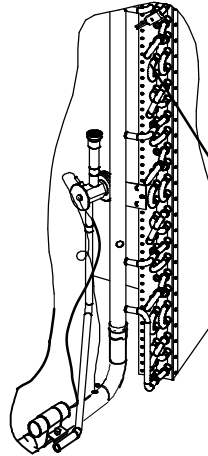

24 TUBES UP
MODELS -048 AND -060

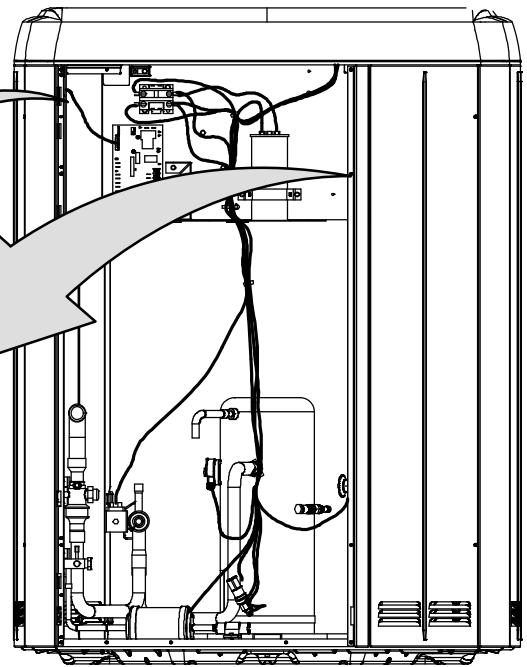

DISCHARGE SENSOR — Not required for this application.

Figure 1. Sensor Locations

Model Number Identification⁶

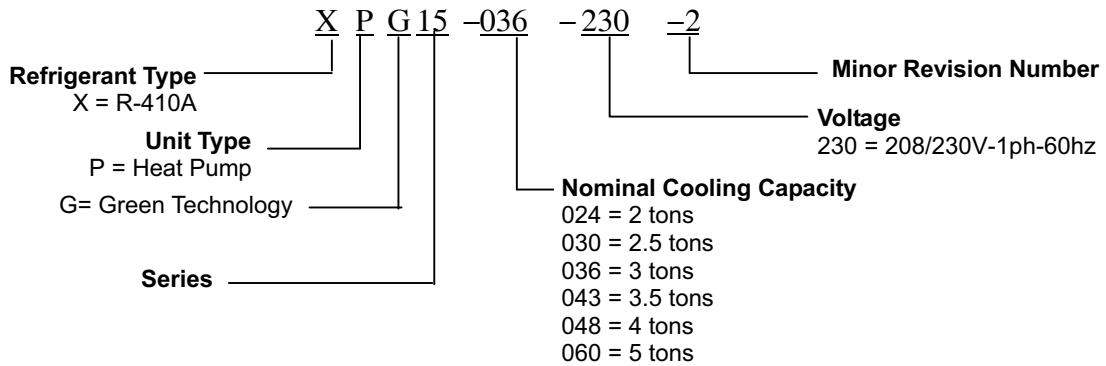

⚠ WARNING

This product and/or the indoor unit it is matched with may contain fiberglass wool.

Disturbing the insulation during installation, maintenance, or repair will expose you to fiberglass wool dust. Breathing this may cause lung cancer. (Fiberglass wool is known to the State of California to cause cancer.)

Fiberglass wool may also cause respiratory, skin, and eye irritation.

To reduce exposure to this substance or for further information, consult material safety data sheets available from address shown below, or contact your supervisor.

Lennox Industries Inc.
P.O. Box 799900
Dallas, TX 75379-9900

Scroll Compressor Operations

The B1 scroll compressor design is simple, efficient and requires few moving parts. A cutaway diagram of the scroll compressor is illustrated in figure 3. The scrolls are located in the top of the compressor can and the motor is located just below. The oil level is immediately below the motor.

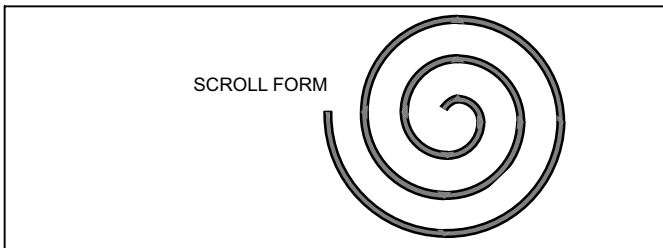

Figure 2. Scroll Form

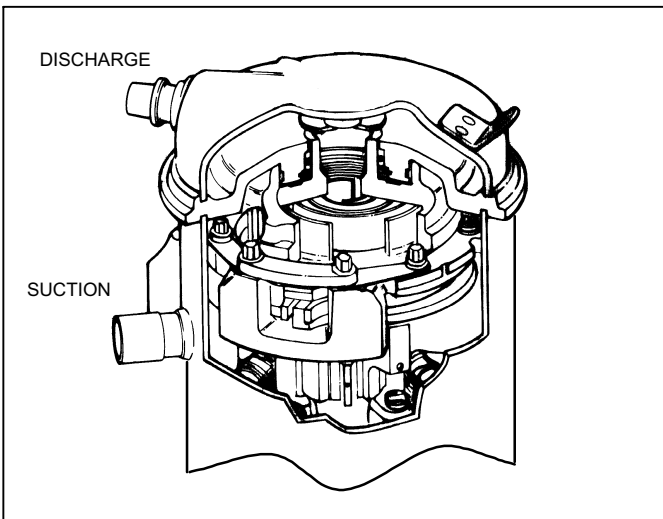

Figure 3. Scroll Compressor

The scroll is a simple compression concept centered around the unique spiral shape of the scroll and its inherent properties. Figure 2 illustrates the basic scroll form. Two identical scrolls are mated together forming concentric spiral shapes as illustrated in figure 4. One scroll remains stationary, while the other is allowed to ORBIT as illustrated in figure 5. Note that the orbiting scroll does not rotate or turn but merely ORBITS the stationary scroll.

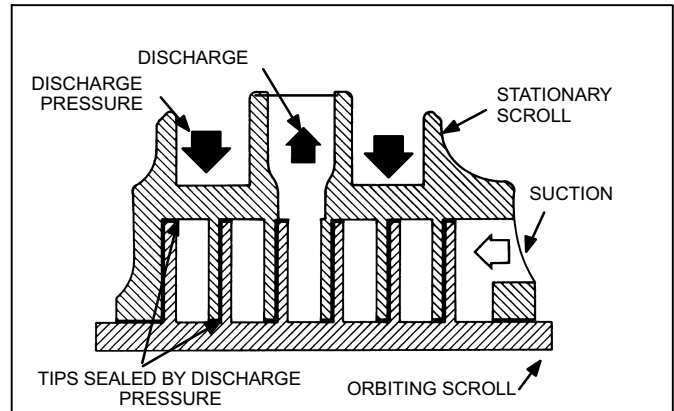

Figure 4. Cross-Section of Scrolls.

The counterclockwise orbiting scroll draws gas into the outer crescent shaped gas pocket created by the two scrolls as illustrated in figure 5, detail 1. The centrifugal action of the orbiting scroll seals off the flanks of the scrolls as illustrated in figure 5, detail 2. As the orbiting motion continues, the gas is forced toward the center of the scroll and the gas pocket becomes compressed as illustrated in figure 5, detail 3. When the compressed gas reaches the center, it is discharged vertically into a chamber and discharge port in the top of the compressor. The discharge pressure forcing down on the top scroll helps seal off the upper and lower edges (tips) of the scrolls as illustrated in figure 4. During a single orbit, several pockets of gas are compressed simultaneously providing smooth continuous compression.

The scroll compressor is tolerant to the effects of liquid return. If liquid enters the scrolls, the orbiting scroll is allowed to separate from the stationary scroll. The liquid is worked toward the center of the scroll and is discharged. If the compressor is replaced, conventional Lennox cleanup practices must be used.

Due to its efficiency, the scroll compressor is capable of drawing a much deeper vacuum than reciprocating compressors. Deep vacuum operation can cause internal fusite arcing resulting in damaged internal parts and will result in compressor failure. This type of damage can be detected and will result in denial of warranty claims. The scroll compressor can be used to pump down refrigerant as long as the pressure is not reduced below 7 psig.

NOTE — During operation, the head of a scroll compressor may be hot since it is in constant contact with discharge gas.

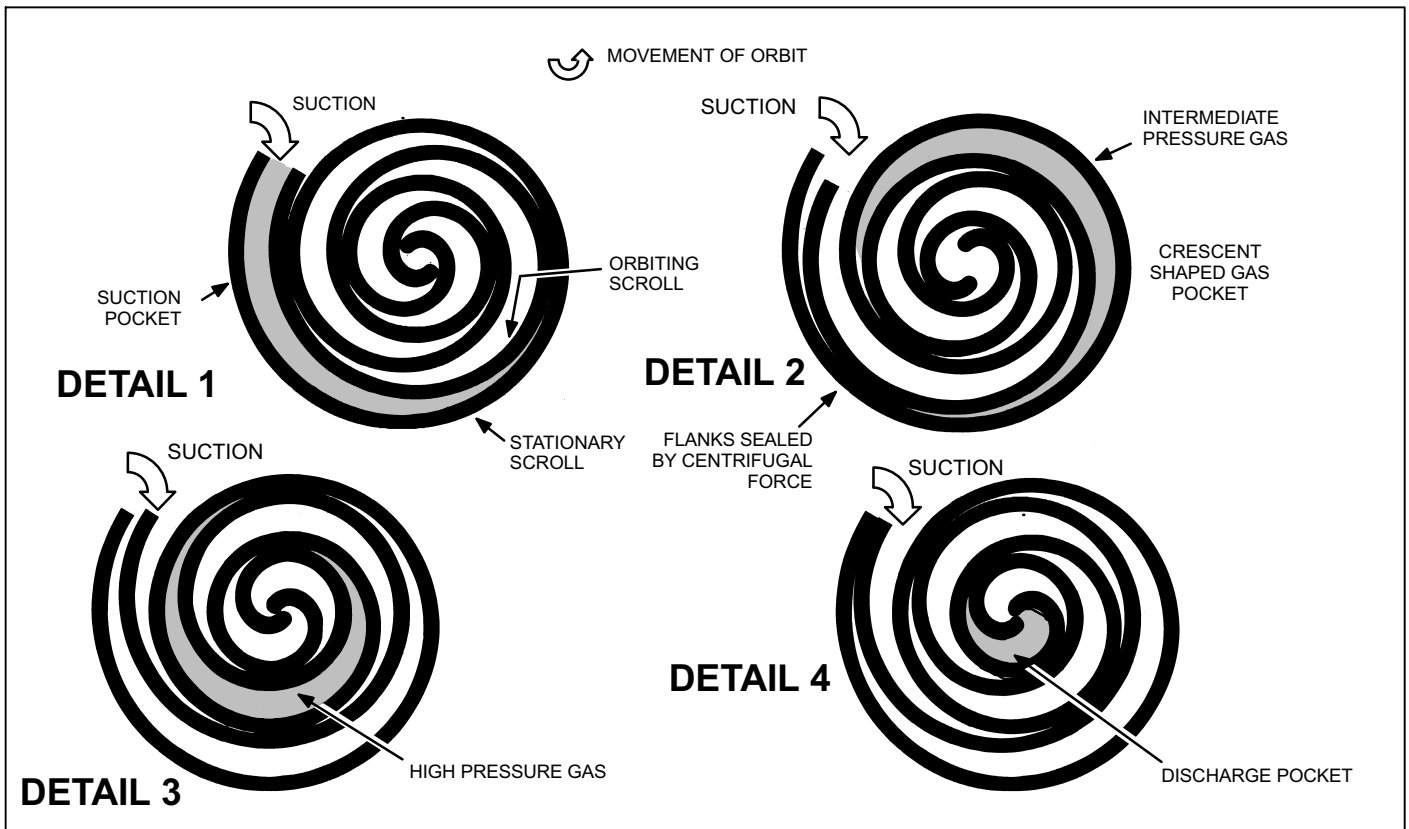

Figure 5. How a Scroll Works

The scroll compressors in all XPG15 model units are designed for use with HFC-410A refrigerant and operation at high pressures. Compressors are shipped from the factory with 3MA (32MMMA) P.O.E. oil. See electrical section in this manual for compressor specifications.

Unit Components⁸

See *Unit Parts and Unit Control Box Parts Arrangement* on page 4 for component locations.

1. CONTACTOR (K1)

The compressor is energized by a contactor located in the control box. All XPG15 units are single phase and single-pole contactors.

A contactor is an electro-magnetic switching device (a relay) used for switching a power or control circuit. A contactor is activated by a control input which is typically a lower voltage than that which the contactor is switching. For location of the contactor see *Control Panel Parts Arrangement* on page 4.

2. HIGH PRESSURE SWITCH (S4)

An auto-reset, single-pole/single-throw high pressure switch is located in the liquid line. See *Unit Parts Arrangement* on page 4 for switch location and *Defrost System* on page 38 for complete details concerning this switch.

3. LOW PRESSURE SWITCH (S87)

The XPG15 is equipped with an auto-reset low pressure switch which is located on the true suction line between the reversing valve and the compressor. See *Unit Parts Arrangement* on page 4 for switch location and *Defrost System* on page 38 for more information.

4. TEMPERATURE SENSORS

Detail information concerning the ambient (RT13) and defrost coil (RT21) sensors is available in section *Defrost System* on page 38.

5. DUAL CAPACITOR (C12)

The compressor and fan in XPG15 2-1/2 to 4 ton units use permanent split capacitor motor. A single DUAL capacitor is used for both the fan motor and the compressor (see unit wiring diagram). The two sides (fan and compressor) of the capacitor have different MFD ratings and may change with each compressor.

The 5-ton unit uses a ECM motor and with the C12 capacitor only used with the compressor. For location of the C12 capacitor see *Control Panel Parts Arrangement* on page 4.

6. CRANKCASE HEATER (HR1)

Compressors in this model are equipped with the following crankcase heaters:

Table 1. Crankcase Heater Electrical Specifications

Unit Size (Tonnage)	Watts	Voltage
2 to 3	40	240VAC
3-1/2 to 5	70	240VAC

HR1 prevents liquid from accumulating in the compressor. HR1 is controlled by the crank case heater thermostat. See *Unit Parts Arrangement* on page 4 for crankcase heater location.

7. CRANKCASE HEATER THERMOSTAT (S40)

Thermostat S40 controls the crankcase heater in all units. S40 is located on the liquid line. When liquid line temperature drops below 50° F the thermostat S40 closes and energizing HR1 crankcase heater. The thermostat will open, de-energizing HR1 crankcase heater once liquid line temperature reaches 70° F. See *Unit Parts Arrangement* on page 4 for crankcase heater thermostat location.

8. CONDENSER FAN MOTOR (B4)

XPG15 units employs two types of fan motors, one type is a single-phase PSC fan motors used on 2 through 4 ton units. A ECM motor is employed on the 5 ton unit. The outdoor fan motor is controlled by the Demand Defrost Control K-1 relay.

9. BI-FLOW LIQUID LINE FILTER DRIER

A liquid line bi-flow filter drier designed for all XPG15 model units is factory installed in the liquid line. The filter drier is designed to remove moisture and foreign matter, which can lead to compressor failure. See *Unit Parts Arrangement* on page 4 for bi-flow liquid line filter drier location.

⚠ CAUTION

Physical contact with metal edges and corners while applying excessive force or rapid motion can result in personal injury. Be aware of, and use caution when working near these areas during installation or while servicing this equipment.

Operating Gauge Set and Service Valves9

These instructions are intended as a general guide and do not supersede local codes in any way. Consult authorities who have jurisdiction before installation.

1. TORQUE REQUIREMENTS

When servicing or repairing HVAC components, ensure the fasteners are appropriately tightened. Table 2 shows torque values for fasteners.

⚠ IMPORTANT

Only use Allen wrenches of sufficient hardness (50Rc - Rockwell Harness Scale minimum). Fully insert the wrench into the valve stem recess.

Service valve stems are factory-torqued (from 9 ft-lbs for small valves, to 25 ft-lbs for large valves) to prevent refrigerant loss during shipping and handling. Using an Allen wrench rated at less than 50Rc risks rounding or breaking off the wrench, or stripping the valve stem recess.

See the Lennox Service and Application Notes #C-08-1 for further details and information.

⚠ IMPORTANT

To prevent stripping of the various caps used, the appropriately sized wrench should be used and fitted snugly over the cap before tightening.

Table 2. Torque Requirements

Parts	Recommended Torque	
Service valve cap	8 ft.- lb.	11 NM
Sheet metal screws	16 in.- lb.	2 NM
Machine screws #10	28 in.- lb.	3 NM
Compressor bolts	90 in.- lb.	10 NM
Gauge port seal cap	8 ft.- lb.	11 NM

2. OPERATING MANIFOLD GAUGE SET

When checking the system charge, only use a manifold gauge set that features low-loss anti-blow back fittings.

Manifold gauge set used with HFC-410A refrigerant systems must be capable of handling the higher system operating pressures. The gauges should be rated for use with pressures of 0 - 800 psig on the high side and a low side of 30" vacuum to 250 psig with dampened speed to 500 psi. Gauge hoses must be rated for use at up to 800 psig of pressure with a 4000 psig burst rating.

Operating Angle Type Service Valve:

1. Remove stem cap with an appropriately sized wrench.
2. Use a service wrench with a hex-head extension (3/16" for liquid line valve sizes and 5/16" for vapor line valve sizes) to back the stem out counterclockwise as far as it will go.

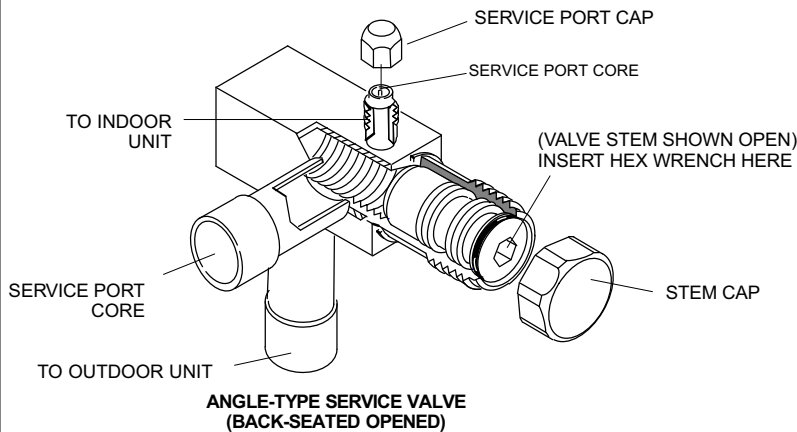

When service valve is **OPEN**, the service port is open to line set, indoor and outdoor unit.

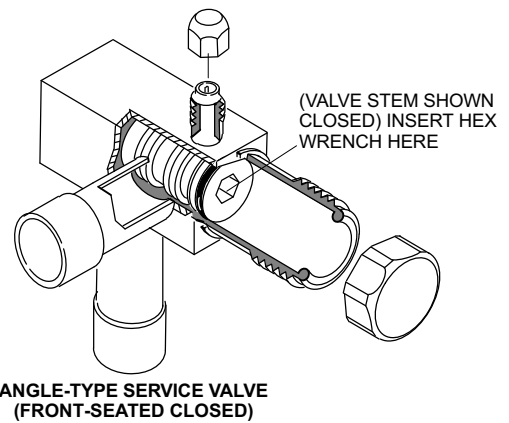

WHEN SERVICE VALVE IS **CLOSED**, THE SERVICE PORT IS OPEN TO THE LINE SET AND INDOOR UNIT.

Operating Ball Type Service Valve:

1. Remove stem cap with an appropriately sized wrench.
2. Use an appropriately sized wrench to open. To open valve, rotate stem counterclockwise 90°. To close rotate stem clockwise 90°.

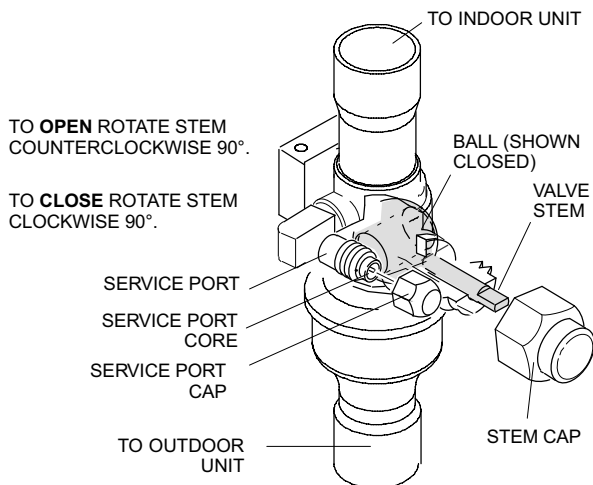

To Access Service Port:

A service port cap protects the service port core from contamination and serves as the primary leak seal.

1. Remove service port cap with an appropriately sized wrench.
2. Connect gauge set to service port.
3. When testing is completed, replace service port cap and tighten as follows:

- With torque wrench: Finger tighten and torque cap per table 2.
- Without torque wrench: Finger tighten and use an appropriately sized wrench to turn an additional 1/6 turn clockwise.

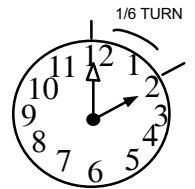

Reinstall Stem Cap:

Stem cap protects the valve stem from damage and serves as the primary seal. Replace the stem cap and tighten as follows:

- With Torque Wrench: Finger tighten and then torque cap per table 2.
- Without Torque Wrench: Finger tighten and use an appropriately sized wrench to turn an additional 1/12 turn clockwise.

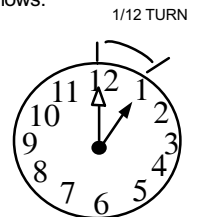

NOTE — A label with specific torque requirements may be affixed to the stem cap. If the label is present, use the specified torque.

Figure 6. Angle and Ball Type Service Valves

RECOVERING

REFRIGERANT FROM SYSTEM

1 DISCONNECT POWER

Disconnect all power to the existing outdoor unit at the disconnect switch or main fuse box/breaker panel.

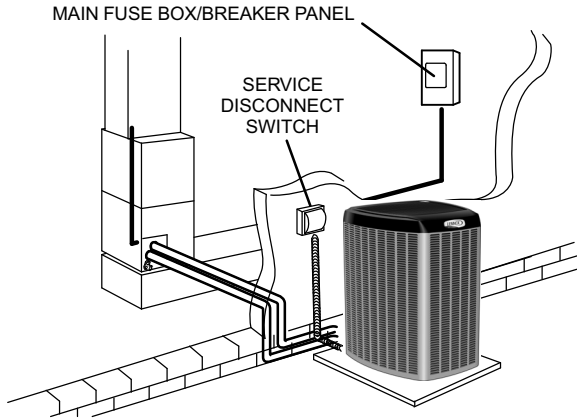

2 CONNECT MANIFOLD GAUGE SET

Connect a gauge set, clean recovery cylinder and a recovery machine to the service ports of the existing unit. Use the instructions provided with the recovery machine to make the connections.

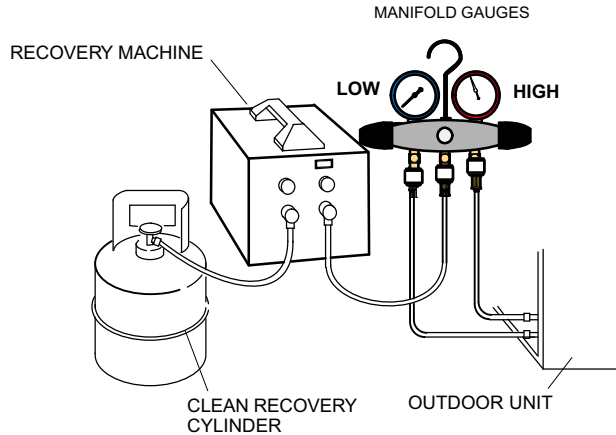

3 RECOVERING REFRIGERANT

Remove existing HCFC-22 refrigerant using one of the following procedures:

IMPORTANT — Some system configurations may contain higher than normal refrigerant charge due to either large internal coil volumes, and/or long line sets.

METHOD 1:

Use this method if the existing outdoor unit is not equipped with shut-off valves, or if the unit is not operational and you plan to use the existing HCFC-22 to flush the system.

Remove all HCFC-22 refrigerant from the existing system. Check gauges after shutdown to confirm that the entire system is completely void of refrigerant.

METHOD 2:

Use this method if the existing outdoor unit is equipped with manual shut-off valves, and you plan to use new HCFC-22 refrigerant to flush the system.

The following devices could prevent full system charge recovery into the outdoor unit:

- Outdoor unit's high or low-pressure switches (if applicable) when tripped can cycle the compressor **OFF**.
- Compressor can stop pumping due to tripped internal pressure relief valve.
- Compressor has internal vacuum protection that is designed to unload the scrolls (compressor stops pumping) when the pressure ratio meets a certain value or when the suction pressure is as high as 20 psig. (Compressor suction pressures should never be allowed to go into a vacuum. Prolonged operation at low suction pressures will result in overheating of the scrolls and permanent damage to the scroll tips, drive bearings and internal seals.)

Once the compressor can not pump down to a lower pressure due to one of the above system conditions, shut off the vapor valve. Turn OFF the main power to unit and use a recovery machine to recover any refrigerant left in the indoor coil and line set.

Perform the following task:

- Start the existing HCFC-22 system in the cooling mode and close the liquid line valve.
- Use the compressor to pump as much of the existing HCFC-22 refrigerant into the outdoor unit until the outdoor system is full. Turn the outdoor unit main power OFF and use a recovery machine to remove the remaining refrigerant from the system.

NOTE — It may be necessary to bypass the low pressure switches (if equipped) to ensure complete refrigerant evacuation.

- When the low side system pressures reach 0 psig, close the vapor line valve.
- Check gauges after shutdown to confirm that the valves are not allowing refrigerant to flow back into the low side of the system.

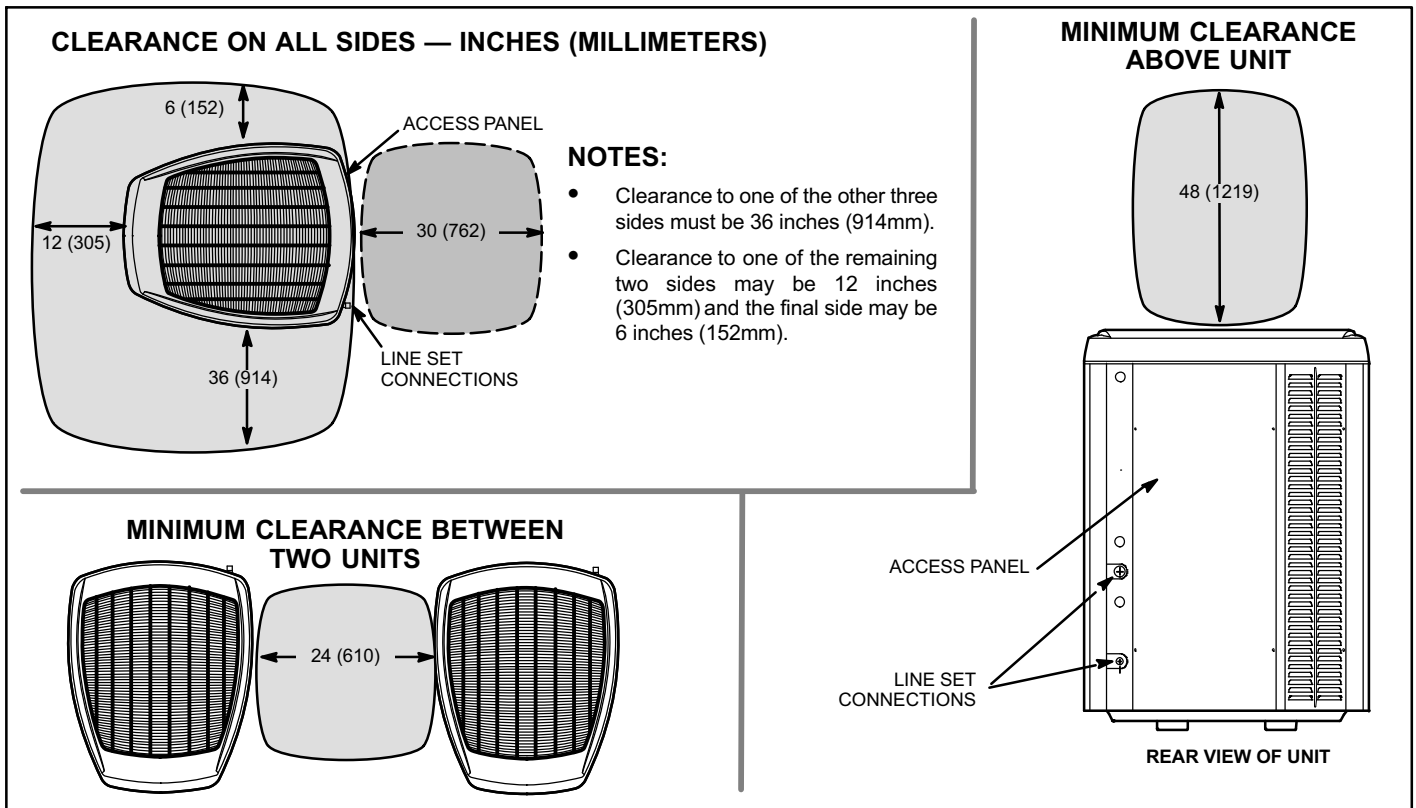

Figure 7. Installation Clearances

Unit Placement¹¹

⚠ CAUTION

In order to avoid injury, take proper precaution when lifting heavy objects.

See *Unit Dimensions* on page 3 for sizing mounting slab, platforms or supports. Refer to figure 7 for mandatory installation clearance requirements.

1. POSITIONING CONSIDERATIONS

Consider the following when positioning the unit:

- Some localities are adopting sound ordinances based on the unit's sound level registered from the adjacent property, not from the installation property. Install the unit as far as possible from the property line.
- When possible, do not install the unit directly outside a window. Glass has a very high level of sound transmission. For proper placement of unit in relation to a window see the provided illustration in figure 8, detail A.

2. PLACING UNIT ON SLAB

When installing unit at grade level, the top of the slab should be high enough above grade so that water from higher ground will not collect around the unit. The slab should have a slope tolerance as described in figure 8, detail B.

NOTE — If necessary for stability, anchor unit to slab as described in figure 8, detail D.

3. ELEVATING THE UNIT

Units are outfitted with elongated support feet as illustrated in figure 8, detail C.

If additional elevation is necessary, raise the unit by extending the height of the unit support feet. This may be achieved by using a 2" SCH 40 female threaded adapter.

The specified coupling will fit snugly into the recessed portion of the feet. Use additional 2" SCH 40 male threaded adaptors which can be threaded into the female threaded adaptors to make additional adjustments to the level of the unit.

NOTE — Keep the height of extenders short enough to ensure a sturdy installation. If it is necessary to extend further, consider a different type of field-fabricated framework that is sturdy enough for greater heights.

DETAIL A

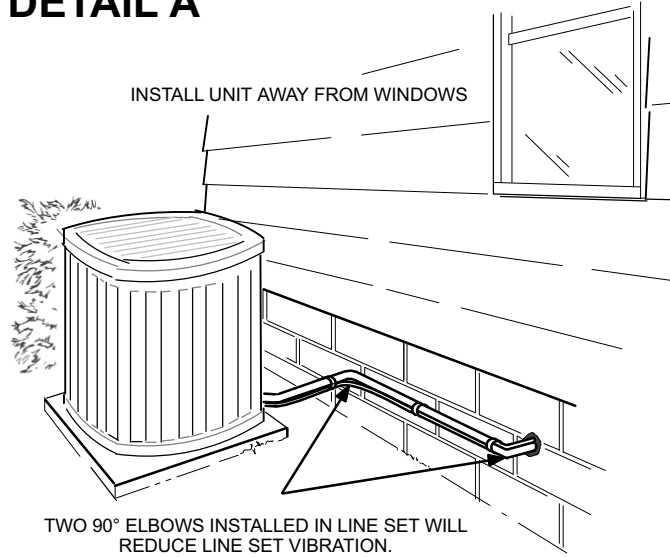

INSTALL UNIT AWAY FROM WINDOWS

TWO 90° ELBOWS INSTALLED IN LINE SET WILL REDUCE LINE SET VIBRATION.

Outside Unit Placement

DETAIL B

INSTALL UNIT LEVEL OR, IF ON A SLOPE, MAINTAIN SLOPE TOLERANCE OF 2 DEGREES (OR 2 INCHES PER 5 FEET [50 MM PER 1.5 M]) AWAY FROM BUILDING STRUCTURE.

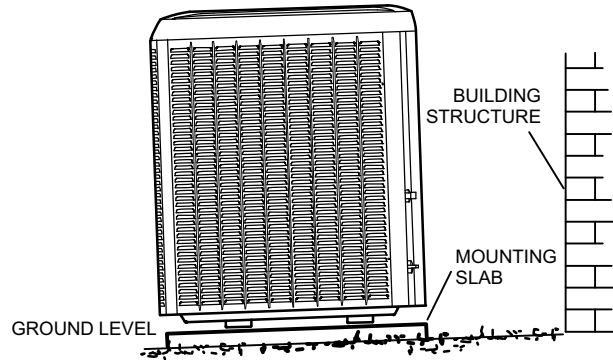

Slab Mounting at Ground Level

DETAIL C

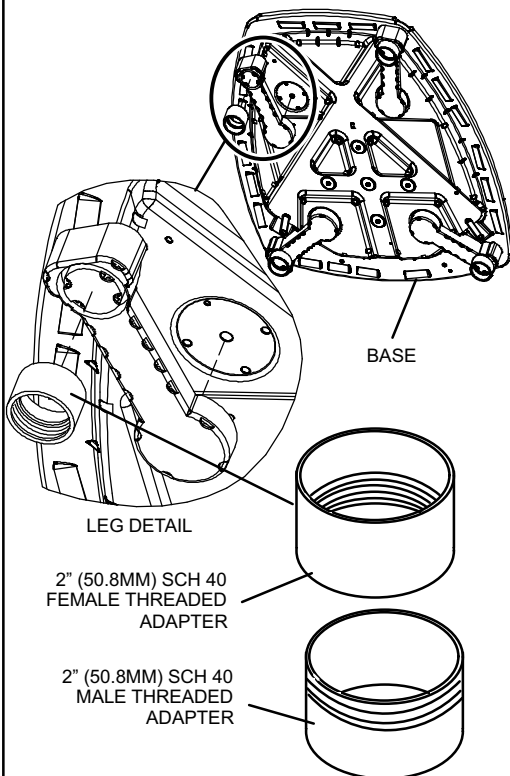

Use additional 2" SCH 40 male threaded adapters which can be threaded into the female threaded adapters to make additional adjustments to the level of the unit.

Elevated Slab Mounting using Feet Extenders

DETAIL D

Slab Side Mounting

#10 1/2" LONG SELF-DRILLING SHEET METAL SCREWS

STABILIZING BRACKET (18 GAUGE METAL — 2" WIDTH; HEIGHT AS REQUIRED)

#10 1-1/4" LONG HEX HD SCREW AND FLATWASHER

CONCRETE SLAB — USE TWO PLASTIC ANCHORS (HOLE DRILL 1/4")

WOOD OR PLASTIC SLAB — NO PLASTIC ANCHOR (HOLE DRILL 1/8")

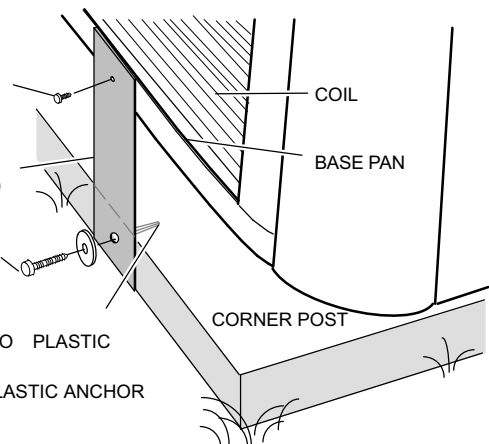

Deck Top Mounting

STABILIZING BRACKET (18 GAUGE METAL — 2" (50.8MM) WIDTH; HEIGHT AS REQUIRED); BEND TO FORM RIGHT ANGLE

SAME FASTENERS AS SLAB SIDE MOUNTING.

MINIMUM ONE PER SIDE

FOR EXTRA STABILITY

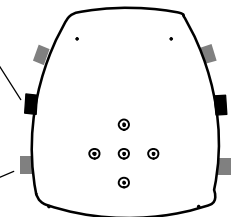
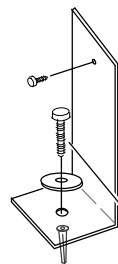

ONE BRACKET PER SIDE (MIN.); FOR EXTRA STABILITY, TWO BRACKETS PER SIDE, 2" (50.8MM) FROM EACH CORNER.

Stabilizing Unit on Uneven Surfaces

IMPORTANT — To help stabilize an outdoor unit, some installations may require strapping the unit to the pad using brackets and anchors commonly available in the marketplace.

Figure 8. Placement, Slab Mounting and Stabilizing Unit

4. STABILIZING UNIT ON UNEVEN SURFACES

⚠ IMPORTANT

Unit Stabilizer Bracket Use (field-provided):

Always use stabilizers when unit is raised above the factory height. (Elevated units could become unstable in gusty wind conditions).

Stabilizers may be used on factory height units when mounted on unstable an uneven surface.

With unit positioned at installation site, perform the following:

- A Remove two side louvered panels to expose the unit base.
- B Install the brackets as illustrated in figure 8, detail D using conventional practices.
- C Replace the panels after installation is complete.

ROOF MOUNTING

Install the unit a minimum of six (6) inches (152 mm) above the roof surface to avoid ice build-up around the unit. Locate the unit above a load bearing wall or area of the roof that can adequately support the unit. Consult local codes for rooftop applications.

If unit coil cannot be mounted away from prevailing winter winds, a wind barrier should be constructed. Size barrier at least the same height and width as outdoor unit. Mount barrier 24 inches (610 mm) from the sides of the unit in the direction of prevailing winds.

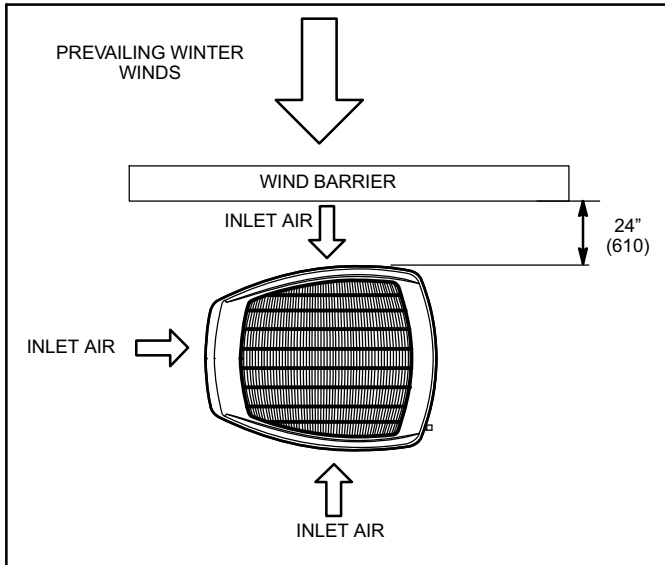

Figure 9. Rooftop Application and Wind Barrier

NOTICE

Roof Damage!

This system contains both refrigerant and oil. Some rubber roofing material may absorb oil and cause the rubber to swell when it comes into contact with oil. The rubber will then bubble and could cause leaks. Protect the roof surface to avoid exposure to refrigerant and oil during service and installation. Failure to follow this notice could result in damage to roof surface.

Removing and Installing Panels¹²

⚠ IMPORTANT

Do not allow panels to hang on unit by top tab. Tab is for alignment and not designed to support weight of panel.

⚠ IMPORTANT

To help stabilize an outdoor unit, some installations may require strapping the unit to the pad using brackets and anchors commonly available in the marketplace.

⚠ WARNING

To prevent personal injury, or damage to panels, unit or structure, be sure to observe the following:

While installing or servicing this unit, carefully stow all removed panels out of the way, so that the panels will not cause injury to personnel, nor cause damage to objects or structures nearby, nor will the panels be subjected to damage (e.g., being bent or scratched).

While handling or stowing the panels, consider any weather conditions, especially windy conditions, that may cause panels to be blown around and battered.

REMOVING AND INSTALLING PANELS

Panel shown slightly rotated to allow top tab to exit (or enter) top slot for removing (or installing) panel.

LOUVERED PANEL REMOVAL

Remove the louvered panels as follows:

1. Remove two screws, allowing the panel to swing open slightly.
2. Hold the panel firmly throughout this procedure. Rotate bottom corner of panel away from hinged corner post until lower three tabs clear the slots as illustrated in **detail B**.
3. Move panel down until lip of upper tab clears the top slot in corner post as illustrated in **detail A**.

LOUVERED PANEL INSTALLATION

Position the panel almost parallel with the unit as illustrated in **detail D** with the screw side as close to the unit as possible. Then, in a continuous motion:

1. Slightly rotate and guide the lip of top tab inward as illustrated in **detail A** and **C**; then upward into the top slot of the hinge corner post.
2. Rotate panel to vertical to fully engage all tabs.
3. Holding the panel's hinged side firmly in place, close the right-hand side of the panel, aligning the screw holes.
4. When panel is correctly positioned and aligned, insert the screws and tighten.

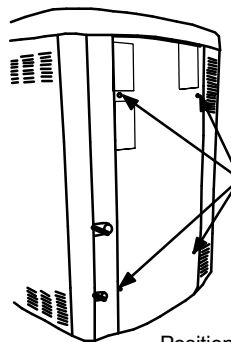

REMOVE 4 SCREWS TO REMOVE PANEL FOR ACCESSING COMPRESSOR AND CONTROLS.

Position panel with holes aligned; install screws and tighten.

Detail A



LIP

Detail B

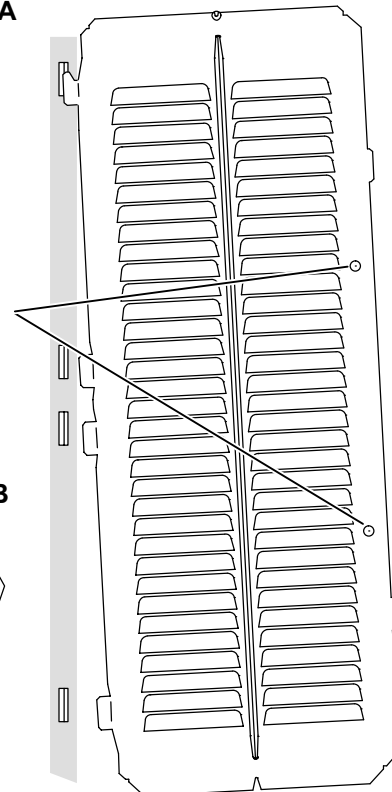

ROTATE IN THIS DIRECTION; THEN DOWN TO REMOVE PANEL

Detail C

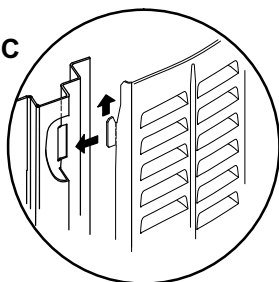

Maintain minimum panel angle (as close to parallel with the unit as possible) while installing panel.

Detail D

ANGLE MAY BE TOO EXTREME

HOLD DOOR FIRMLY ALONG THE HINGED SIDE TO MAINTAIN FULLY-ENGAGED TABS

PREFERRED ANGLE FOR INSTALLATION

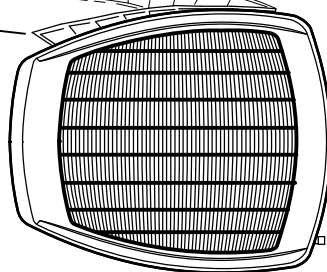

Figure 10. Removing and Installing Panels

New or Replacement Line Set13

REFRIGERANT LINE SET

This section provides information on installation or replacement of existing line set. If new or replacement line set is not being installed then proceed to *Brazing Connections* on page 17.

⚠ IMPORTANT

Lennox highly recommends changing line set when converting the existing system from HCFC-22 to HFC-410A. If that is not possible and the line set is the proper size as reference in table 2, use the procedure outlined under *Flushing* on page 17.

If refrigerant lines are routed through a wall, then seal and isolate the opening so vibration is not transmitted to the building. Pay close attention to line set isolation during installation of any HVAC system. When properly isolated from building structures (walls, ceilings, floors), the refrigerant lines will not create unnecessary vibration and subsequent sounds. See figure 11 for recommended installation practices. Also, consider the following when placing and installing a high-efficiency outdoor unit.

⚠ IMPORTANT

Refrigerant lines must not contact structure.

Liquid lines that meter the refrigerant, such as RFC1 liquid lines, must not be used in this application. Existing line set of proper size as listed in table 3 may be reused. If system was previously charged with HCFC-22 refrigerant, then existing line set must be flushed (see *Flushing the System* on page 20).

Field refrigerant piping consists of liquid and vapor lines from the outdoor unit to the indoor unit coil (braze connections). Use Lennox L15 (sweat, non-flare) series line set, or field-fabricated refrigerant line sizes as listed in table 3.

Table 3. Refrigerant Line Set — Inches (Millimeters)

Model	Valve Sizes		Recommended Line Set		
	Liquid Line	Vapor Line	Liquid Line	Vapor Line	L15 Line Sets
-024	3/8" (10)	3/4" (19)	3/8" (10)	3/4" (19)	L15-41 15 - 50 feet (5 - 15 meters)
-030					
-036	3/8" (10)	7/8" (22)	3/8" (10)	7/8" (22)	L15-65 15 - 50 feet (5 - 15 meters)
-042					
-048					
-060	3/8" (10)	1-1/8" (29)	3/8" (10)	1-1/8" (29)	Field Fabricated

NOTE — When installing refrigerant lines longer than 50 feet, see the *Lennox Refrigerant Piping Design and Fabrication Guidelines*, or contact *Lennox Technical Support Product Applications* for assistance.

To obtain the correct information from Lennox, be sure to communicate the following information:

- Model (XP) and size of unit (e.g. -036).
- Line set diameters for the unit being installed as listed in table 3 and total length of installation.
- Number of elbows vertical rise or drop in the piping.

The compressor is charged with sufficient Polyol Ester oil (POE) for line set lengths up to 50 feet. Recommend adding oil to system based on the amount of refrigerant charge in the system. Systems with 20 pounds or less of refrigerant required no oil to be added.

For systems over 20 pounds - add one ounce for every five (5) pounds of HFC-410A refrigerant.

Recommended POE oils are Mobil EAL ARCTIC 22 CC or ICI EMKARATE™ RL32CF.

⚠ IMPORTANT

If this unit is being matched with an approved line set or indoor unit coil which was previously charged with mineral oil, or if it is being matched with a coil which was manufactured before January of 1999, the coil and line set must be flushed prior to installation. Take care to empty all existing traps. Polyol ester (POE) oils are used in Lennox units charged with HFC-410A refrigerant. Residual mineral oil can act as an insulator, preventing proper heat transfer. It can also clog the expansion device, and reduce the system performance and capacity. Failure to properly flush the system per the instructions below will void the warranty.

⚠ WARNING

Polyol ester (POE) oils used with HFC-410A refrigerant absorb moisture very quickly. It is very important that the refrigerant system be kept closed as much as possible. DO NOT remove line set caps or service valve stub caps until you are ready to make connections.

⚠ IMPORTANT

Mineral oils are not compatible with HFC-410A. If oil must be added, it must be a Polyol Ester oil.

LINE SET

IMPORTANT — Refrigerant lines must not contact structure.

INSTALLATION

Line Set Isolation — The following illustrations are examples of proper refrigerant line set isolation:

REFRIGERANT LINE SET — TRANSITION FROM VERTICAL TO HORIZONTAL

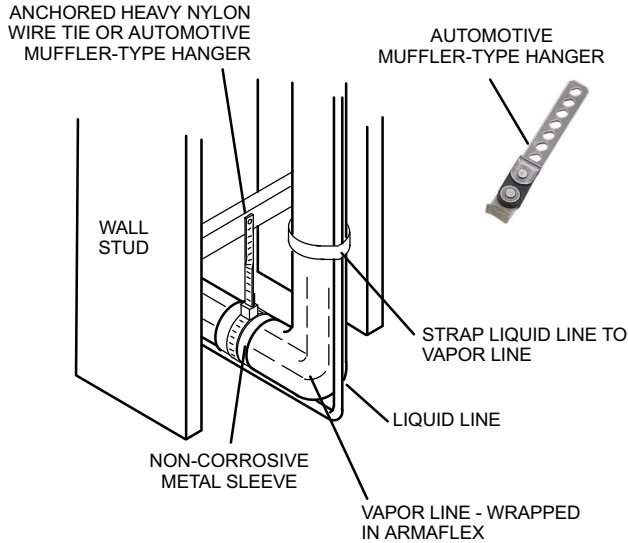

REFRIGERANT LINE SET — INSTALLING HORIZONTAL RUNS

To hang line set from joist or rafter, use either metal strapping material or anchored heavy nylon wire ties.

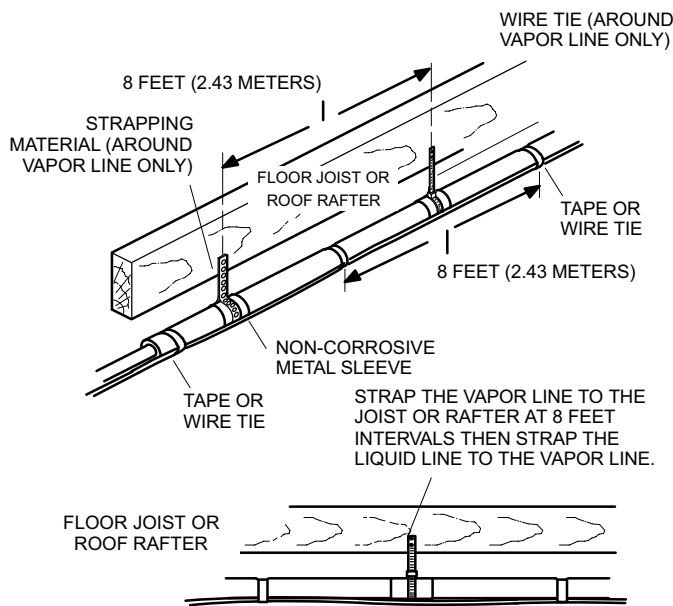

REFRIGERANT LINE SET — INSTALLING VERTICAL RUNS (NEW CONSTRUCTION SHOWN)

NOTE — Insulate liquid line when it is routed through areas where the surrounding ambient temperature could become higher than the temperature of the liquid line or when pressure drop is equal to or greater than 20 psig.

IMPORTANT — Refrigerant lines must not contact wall

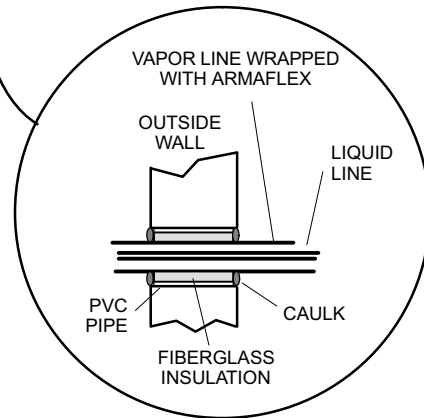
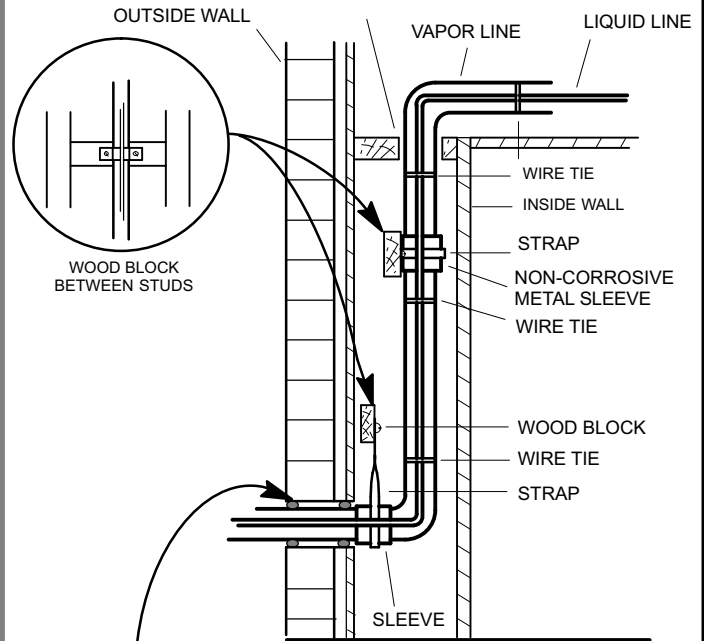

NOTE — Similar installation practices should be used if line set is to be installed on exterior of outside wall.

Figure 11. Line Set Installation

Brazing Connections 14

Use the procedures outline in figures 12 and 13 for brazing line set connections to service valves.

WARNING



Danger of fire. Bleeding the refrigerant charge from only the high side may result in pressurization of the low side shell and suction tubing. Application of a brazing torch to a pressurized system may result in ignition of the refrigerant and oil mixture - Check the high and low pressures before applying heat.

WARNING



When using a high pressure gas such as dry nitrogen to pressurize a refrigeration or air conditioning system, use a regulator that can control the pressure down to 1 or 2 psig (6.9 to 13.8 kPa).

CAUTION

Brazing alloys and flux contain materials which are hazardous to your health.

Avoid breathing vapors or fumes from brazing operations. Perform operations only in well-ventilated areas.

Wear gloves and protective goggles or face shield to protect against burns.

Wash hands with soap and water after handling brazing alloys and flux.

IMPORTANT

Connect gauge set low pressure side to vapor line service valve and repeat procedure starting at paragraph 4 for brazing the liquid line to service port valve.

IMPORTANT

Allow braze joint to cool before removing the wet rag from the service valve. Temperatures above 250°F can damage valve seals.

IMPORTANT

Use silver alloy brazing rods with 5% minimum silver alloy for copper-to-copper brazing. Use 45% minimum alloy for copper-to-brass and copper-to-steel brazing.

WARNING



Fire, Explosion and Personal Safety Hazard.

Failure to follow this warning could result in damage, personal injury or death.

Never use oxygen to pressurize or purge refrigeration lines. Oxygen, when exposed to a spark or open flame, can cause fire and/or an explosion, that could result in property damage, personal injury or death.

1 PIPING PANEL REMOVAL AND PREPARING LINE SET

Remove piping panel for easier access to service valves. Cut ends of the refrigerant lines square (free from nicks or dents) and debur the ends. The pipe must remain round. Do not crimp end of the line.

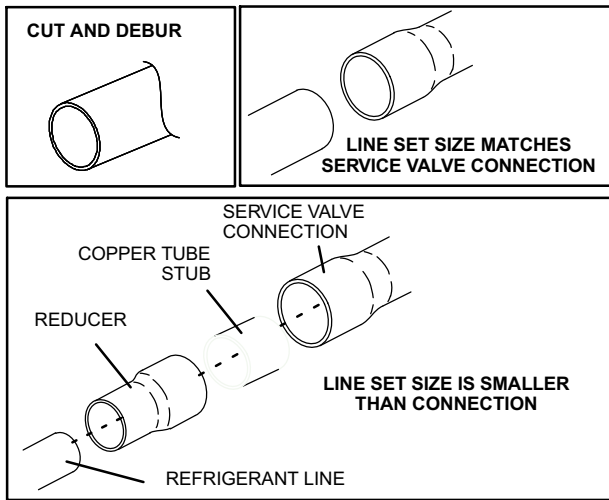

DO NOT CRIMP SERVICE VALVE CONNECTOR WHEN PIPE IS SMALLER THAN CONNECTION

2 CAP AND CORE REMOVAL

Remove service cap and core from both the suction / vapor and liquid line service ports.

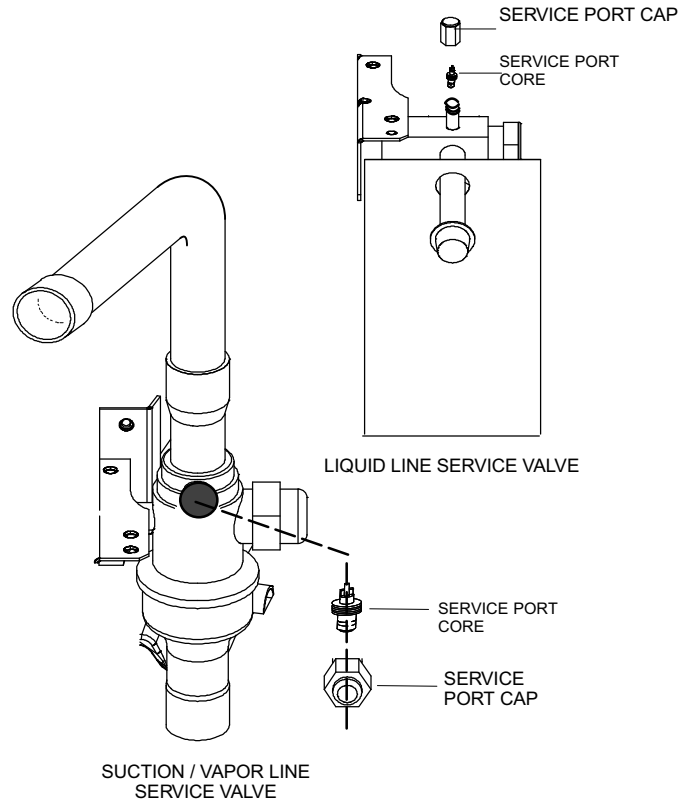

3 ATTACH THE MANIFOLD GAUGE SET FOR BRAZING LIQUID AND SUCTION / VAPOR LINE SERVICE VALVES

- A Connect gauge set low pressure side to liquid line service valve (service port).
- B Connect gauge set center port to bottle of nitrogen with regulator.
- C With valve core removed from the suction / vapor line service port, nitrogen flow will have an exit point.

SUCTION / VAPOR SERVICE PORT MUST BE OPEN AND SERVICE PORT CORE REMOVED TO ALLOW EXIT POINT FOR NITROGEN FLOW

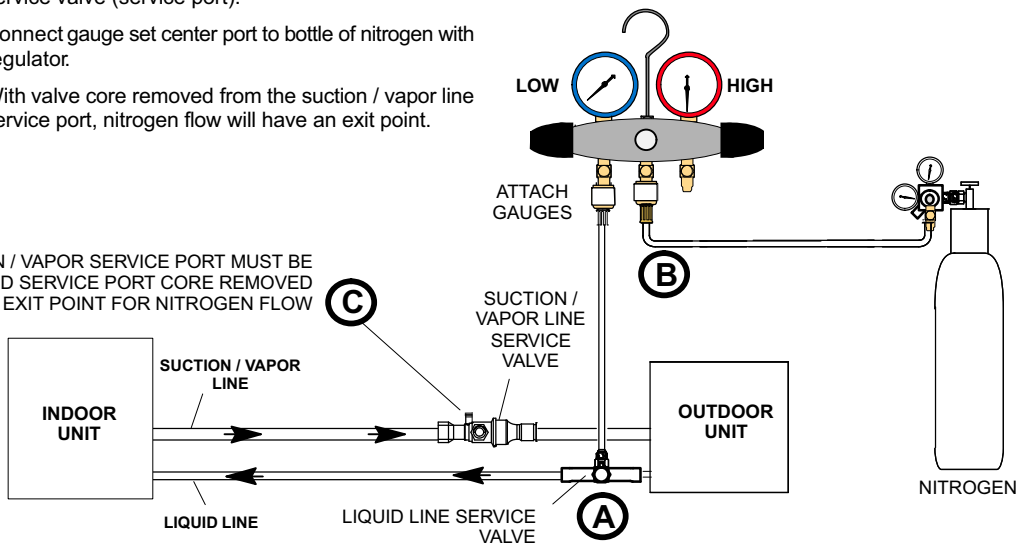

Figure 12. Brazing Procedures

4 WRAP SERVICE VALVES

To help protect service valve seals during brazing, wrap water saturated cloths around service valve bodies and copper tube stubs. Use additional water saturated cloths underneath the valve body to protect the base paint.

5 FLOW NITROGEN

Flow regulated nitrogen (at 1 to 2 psig) through the refrigeration gauge set into the valve stem port connection on the liquid service valve and out of the suction / vapor valve stem port. See steps 3A, 3B and 3C on previous page and below for manifold gauge setup.



WARNING

1. **FIRE, PERSONAL INJURY, OR PROPERTY DAMAGE** will result if you do not wrap a water saturated cloth around both liquid and suction line service valve bodies and copper tube stub while brazing in the line set! The braze, when complete, must be quenched with water to absorb any residual heat.
2. Do not open service valves until refrigerant lines and indoor coil have been leak-tested and evacuated. Refer to procedures provided in this supplement.

6 BRAZE LINE SET

Water saturated cloths must remain water saturated throughout the brazing and cool-down process.

- A Braze liquid line to liquid line service valve.
- B Braze suction / vapor line to suction / vapor service valve.

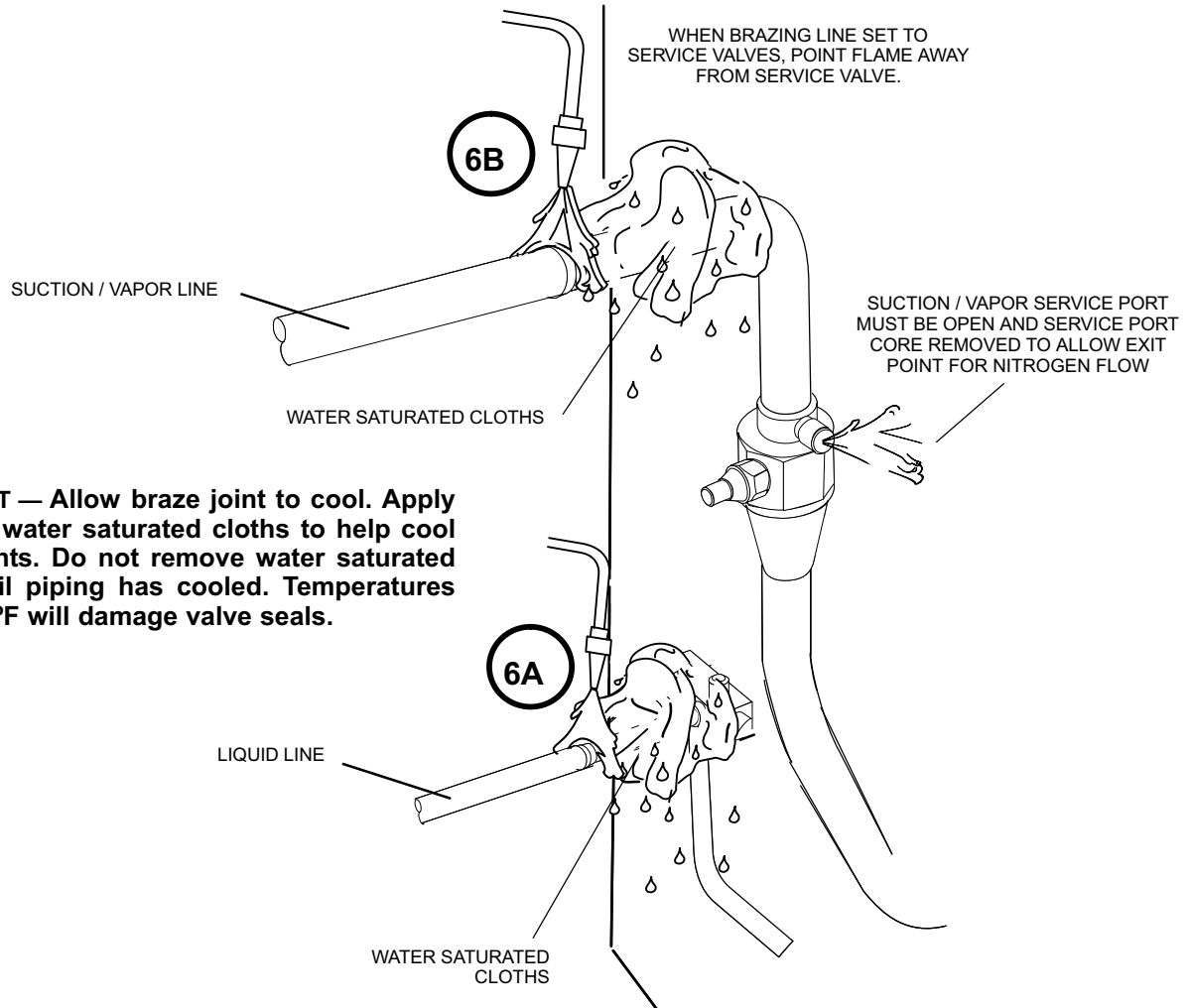

IMPORTANT — Allow braze joint to cool. Apply additional water saturated cloths to help cool brazed joints. Do not remove water saturated cloths until piping has cooled. Temperatures above 250°F will damage valve seals.

7 PREPARATION FOR NEXT STEP

After all connections have been brazed, disconnect manifold gauge set from service ports. Apply additional water saturated cloths to both services valves to cool piping. Once piping is cool, remove all water saturated cloths. Refer to the unit installation instructions for the next step in preparing the unit.

Figure 13. Brazing Procedures (Continued)

Flushing 15

The following procedure should not be performed on a system which contain contaminants (i.e., compressor burn out).

1A TYPICAL EXISTING FIXED ORIFICE REMOVAL PROCEDURE (UNCASED OR COIL SHOWN)

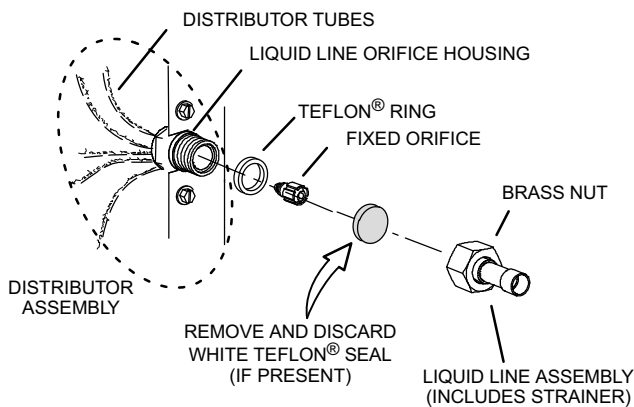

- A** On fully cased coils, remove the coil access and plumbing panels.
- B** Remove any shipping clamps holding the liquid line and distributor assembly.
- C** Using two wrenches, disconnect liquid line from liquid line orifice housing. Take care not to twist or damage distributor tubes during this process.
- D** Remove and discard fixed orifice, valve stem assembly if present and Teflon® washer as illustrated above.
- E** Use a field-provided fitting to temporary reconnect the liquid line to the indoor unit's liquid line orifice housing.

1B TYPICAL EXISTING EXPANSION VALVE REMOVAL PROCEDURE (UNCASED COIL SHOWN)

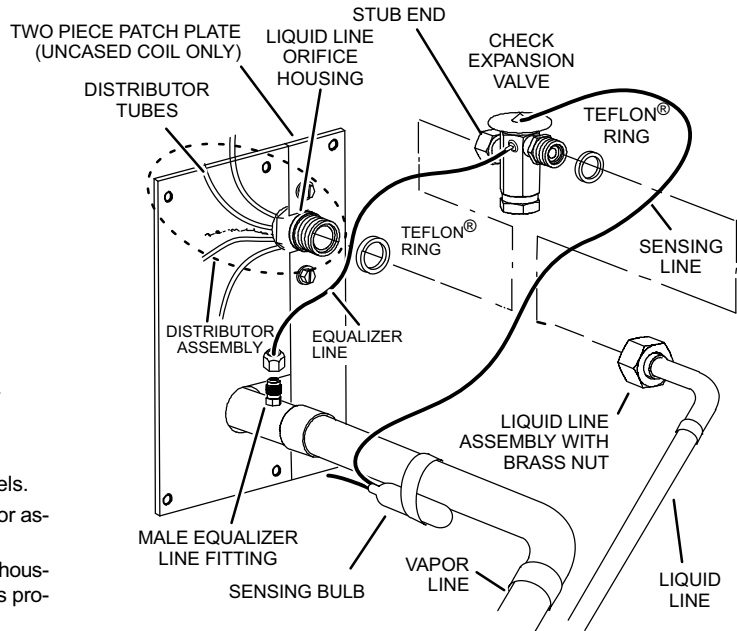

- A** On fully cased coils, remove the coil access and plumbing panels.
- B** Remove any shipping clamps holding the liquid line and distributor assembly.
- C** Disconnect the equalizer line from the check expansion valve equalizer line fitting on the vapor line.
- D** Remove the vapor line sensing bulb.
- E** Disconnect the liquid line from the check expansion valve at the liquid line assembly.
- F** Disconnect the check expansion valve from the liquid line orifice housing. Take care not to twist or damage distributor tubes during this process.
- G** Remove and discard check expansion valve and the two Teflon® rings.
- H** Use a field-provided fitting to temporary reconnect the liquid line to the indoor unit's liquid line orifice housing.

2 CONNECT GAUGES AND EQUIPMENT FOR FLUSHING PROCEDURE

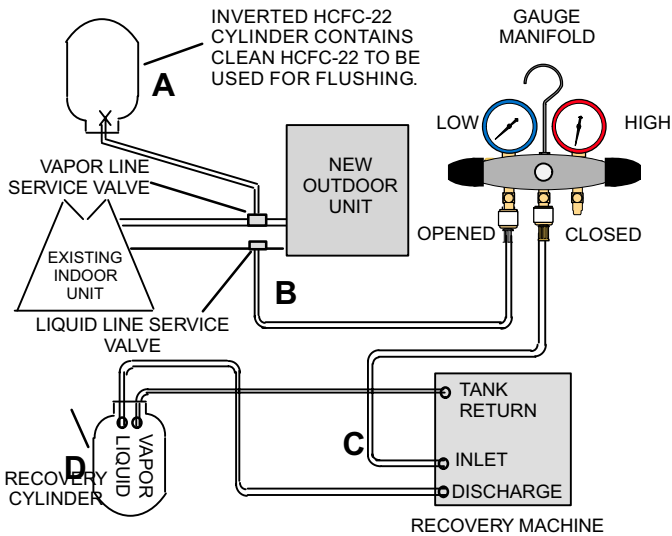

- A** Inverted HCFC-22 cylinder with clean refrigerant to the vapor service valve.
- B** HCFC-22 gauge set (low side) to the liquid line valve.
- C** HCFC-22 gauge set center port to inlet on the recovery machine with an empty recovery tank to the gauge set.
- D** Connect recovery tank to recovery machines per machine instructions.

3 FLUSHING LINE SET

The line set and indoor unit coil must be flushed with at least the same amount of clean refrigerant that previously charged the system. Check the charge in the flushing cylinder before proceeding.

- A** Set the recovery machine for liquid recovery and start the recovery machine. Open the gauge set valves to allow the recovery machine to pull a vacuum on the existing system line set and indoor unit coil.
- B** Invert the cylinder of clean HCFC-22 and open its valve to allow liquid refrigerant to flow into the system through the vapor line valve. Allow the refrigerant to pass from the cylinder and through the line set and the indoor unit coil before it enters the recovery machine.
- C** After all of the liquid refrigerant has been recovered, switch the recovery machine to vapor recovery so that all of the HCFC-22 vapor is recovered. Allow the recovery machine to pull down to 0 the system.
- D** Close the valve on the inverted HCFC-22 drum and the gauge set valves. Pump the remaining refrigerant out of the recovery machine and turn the machine off.

Figure 14. Flushing Line Set and Indoor Coil

⚠ IMPORTANT

The Environmental Protection Agency (EPA) prohibits the intentional venting of HFC refrigerants during maintenance, service, repair and disposal of appliance. Approved methods of recovery, recycling or reclaiming must be followed.

⚠ IMPORTANT

If this unit is being matched with an approved line set or indoor unit coil which was previously charged with mineral oil, or if it is being matched with a coil which was manufactured before January of 1999, the coil and line set must be flushed prior to installation. Take care to empty all existing traps. Polyol ester (POE) oils are used in Lennox units charged with HFC-410A refrigerant. Residual mineral oil can act as an insulator, preventing proper heat transfer. It can also clog the expansion device, and reduce the system performance and capacity. Failure to properly flush the system per the instructions below will void the warranty.

Leak Testing16

⚠ IMPORTANT

Leak detector must be capable of sensing HFC refrigerant.

⚠ WARNING



When using a high pressure gas such as dry nitrogen to pressurize a system, use a regulator that can control the pressure down to 1 or 2 psig (6.9 to 13.8 kPa).

⚠ WARNING

Refrigerant can be harmful if it is inhaled. Refrigerant must be used and recovered responsibly.

Failure to follow this warning may result in personal injury or death.

1 CONNECT GAUGE SET

- A** Connect an HFC-410A manifold gauge set high pressure hose to the vapor valve service port.

NOTE — Normally, the high pressure hose is connected to the liquid line port. However, connecting it to the vapor port better protects the manifold gauge set from high pressure damage.

- B** With both manifold valves closed, connect the cylinder of HFC-410A refrigerant to the center port of the manifold gauge set.

NOTE — Later in the procedure, the HFC-410A container will be replaced by the nitrogen container.

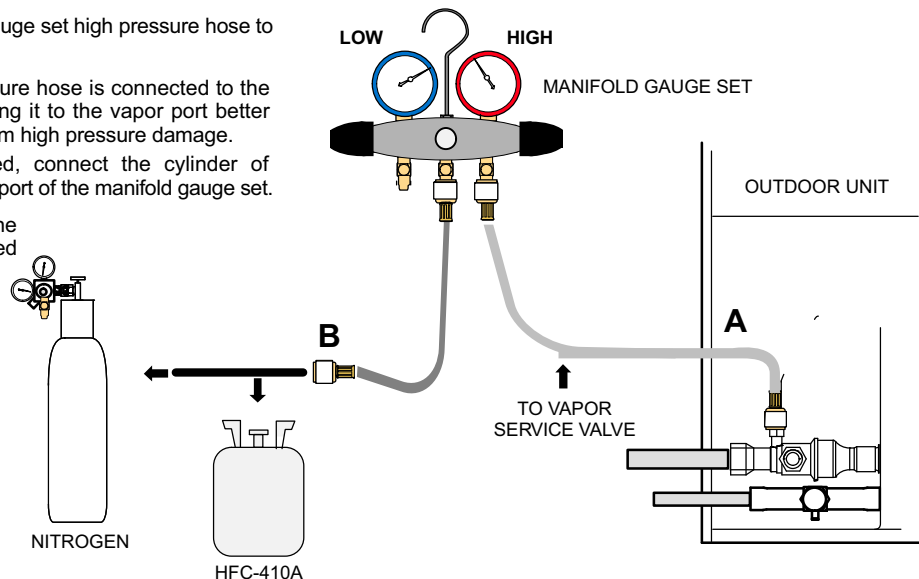

2 TEST FOR LEAKS

After the line set has been connected to the indoor and outdoor units, check the line set connections and indoor unit for leaks. Use the following procedure to test for leaks:

- A** With both manifold valves closed, connect the cylinder of HFC-410A refrigerant to the center port of the manifold gauge set. Open the valve on the HFC-410A cylinder (vapor only).
- B** Open the high pressure side of the manifold to allow HFC-410A into the line set and indoor unit. Weigh in a trace amount of HFC-410A. [A trace amount is a maximum of two ounces (57 g) refrigerant or three pounds (31 kPa) pressure]. Close the valve on the HFC-410A cylinder and the valve on the high pressure side of the manifold gauge set. Disconnect the HFC-410A cylinder.
- C** Connect a cylinder of dry nitrogen with a pressure regulating valve to the center port of the manifold gauge set.
- D** Adjust dry nitrogen pressure to 150 psig (1034 kPa). Open the valve on the high side of the manifold gauge set in order to pressurize the line set and the indoor unit.
- E** After a few minutes, open one of the service valve ports and verify that the refrigerant added to the system earlier is measurable with a leak detector.
- F** After leak testing disconnect gauges from service ports.

Figure 15. Leak Test

Evacuating17

1 CONNECT GAUGE SET

NOTE — Remove cores from service valves (if not already done).

- A** Connect low side of manifold gauge set with 1/4 SAE in-line tee to vapor line service valve
- B** Connect high side of manifold gauge set to liquid line service valve
- C** Connect micron gauge available connector on the 1/4 SAE in-line tee.
- D** Connect the vacuum pump (with nitrogen gauge) to the center port of the manifold gauge set. The center port line will be used later for both the HFC-410A and nitrogen containers.

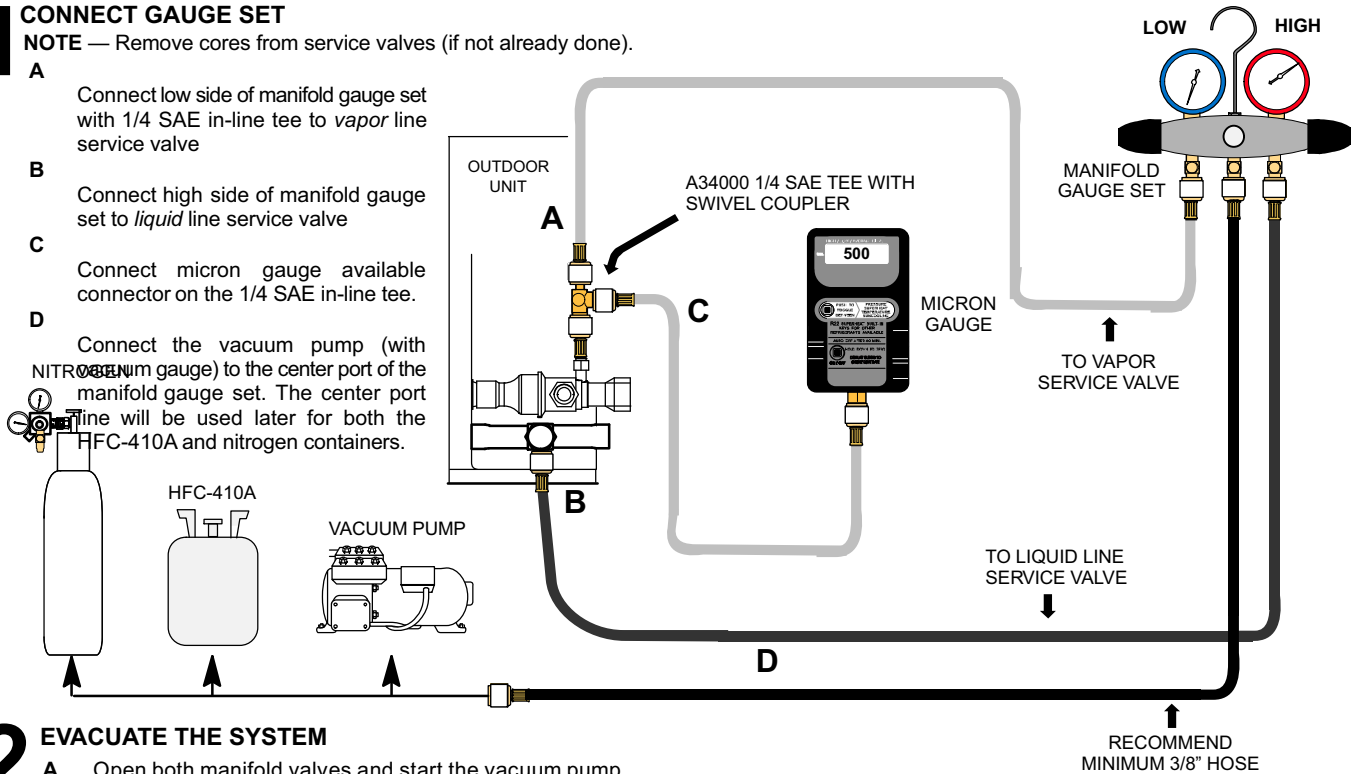

2 EVACUATE THE SYSTEM

- A** Open both manifold valves and start the vacuum pump.
- B** Evacuate the line set and indoor unit to an **absolute pressure** of 23,000 microns (29.01 inches of mercury).
 - NOTE** — During the early stages of evacuation, it is desirable to close the manifold gauge valve at least once. A rapid rise in pressure indicates a relatively large leak. If this occurs, **repeat the leak testing procedure**.
 - NOTE** — The term **absolute pressure** means the total actual pressure within a given volume or system, above the absolute zero of pressure. Absolute pressure in a vacuum is equal to atmospheric pressure minus vacuum pressure.
- C** When the absolute pressure reaches 23,000 microns (29.01 inches of mercury), perform the following:
 - Close manifold gauge valves
 - Close valve on vacuum pump
 - Turn off vacuum pump
 - Disconnect manifold gauge center port hose from vacuum pump
 - Attach manifold center port hose to a dry nitrogen cylinder with pressure regulator set to 150 psig (1034 kPa) and purge the hose.
 - Open manifold gauge valves to break the vacuum in the line set and indoor unit.
 - Close manifold gauge valves.
- D** Shut off the dry nitrogen cylinder and remove the manifold gauge hose from the cylinder. Open the manifold gauge valves to release the dry nitrogen from the line set and indoor unit.
- E** Reconnect the manifold gauge to the vacuum pump, turn the pump on, and continue to evacuate the line set and indoor unit until the absolute pressure does not rise above 500 microns (29.9 inches of mercury) within a 20-minute period after shutting off the vacuum pump and closing the manifold gauge valves.
- F** When the absolute pressure requirement above has been met, disconnect the manifold hose from the vacuum pump and connect it to an upright cylinder of HFC-410A refrigerant. Open the manifold gauge valve 1 to 2 psig in order to release the vacuum in the line set and indoor unit.
- G** Perform the following:
 - Close manifold gauge valves.
 - Shut off HFC-410A cylinder.
 - Reinstall service valve cores by removing manifold hose from service valve. Quickly install cores with core tool while maintaining a positive system pressure.
 - Replace stem caps and secure finger tight, then tighten an additional one-sixth (1/6) of a turn as illustrated.

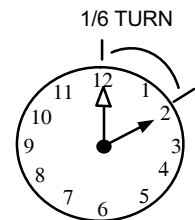

Figure 16. Evacuating System

⚠ IMPORTANT

Use a thermocouple or thermistor electronic vacuum gauge that is calibrated in microns. Use an instrument capable of accurately measuring down to 50 microns.

⚠ WARNING

Danger of Equipment Damage. Avoid deep vacuum operation. Do not use compressors to evacuate a system. Extremely low vacuums can cause internal arcing and compressor failure. Damage caused by deep vacuum operation will void warranty.

Evacuating the system of non-condensables is critical for proper operation of the unit. Non-condensables are defined as any gas that will not condense under

temperatures and pressures present during operation of an air conditioning system. Non-condensables and water suction combine with refrigerant to produce substances that corrode copper piping and compressor parts.

Electrical18

In the U.S.A., wiring must conform with current local codes and the current National Electric Code (NEC). In Canada, wiring must conform with current local codes and the current Canadian Electrical Code (CEC).

Refer to the furnace installation instructions for additional wiring application diagrams and refer to unit nameplate for minimum circuit ampacity and maximum overcurrent protection size.

1. 24VAC TRANSFORMER

Use the transformer provided with the furnace or air handler for low-voltage control power (24VAC - 40 VA minimum)

1 SIZE CIRCUIT AND INSTALL DISCONNECT SWITCH

Refer to the unit nameplate for minimum circuit ampacity, and maximum fuse or circuit breaker (HACR per NEC). Install power wiring and properly sized disconnect switch.

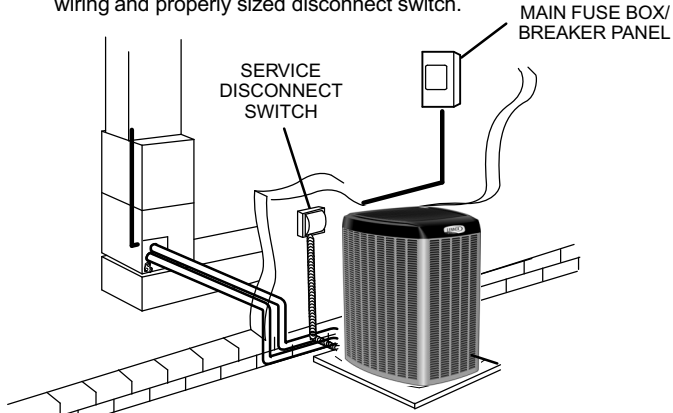

NOTE — Units are approved for use only with copper conductors. Ground unit at disconnect switch or to an earth ground.

2 INSTALL THERMOSTAT

Install room thermostat (ordered separately) on an inside wall approximately in the center of the conditioned area and 5 feet (1.5m) from the floor. It should not be installed on an outside wall or where it can be affected by sunlight or drafts.

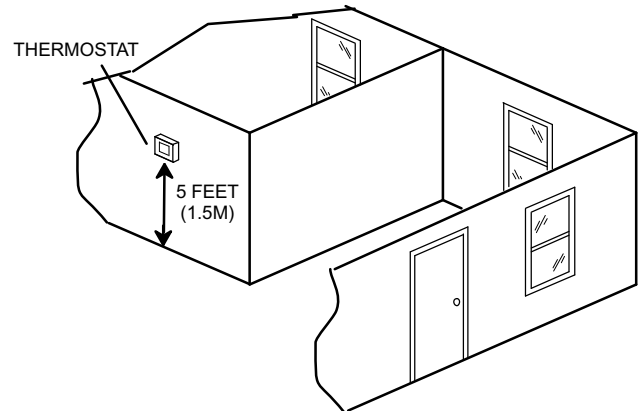

NOTE — 24VAC, Class II circuit connections are made in the control panel.

⚠ WARNING



Electric Shock Hazard. Can cause injury or death. Unit must be grounded in accordance with national and local codes.

Line voltage is present at all components when unit is not in operation on units with single-pole contactors. Disconnect all remote electric power supplies before opening access panel. Unit may have multiple power supplies.

⚠ CAUTION

ELECTROSTATIC DISCHARGE (ESD) Precautions and Procedures

Electrostatic discharge can affect electronic components. Take precautions during unit installation and service to protect the unit's electronic controls. Precautions will help to avoid control exposure to electrostatic discharge by putting the unit, the control and the technician at the same electrostatic potential. Neutralize electrostatic charge by touching hand and all tools on an unpainted unit surface before performing any service procedure

3 ROUTE THERMOSTAT WIRES

Install low voltage wiring from outdoor to indoor unit and from thermostat to indoor unit as illustrated.

- A Run 24VAC control wires through hole with grommet.
- B Make 24VAC thermostat wire connections.

NOTE — Do not bundle any excess 24VAC control wires inside control box.

SEE PAGE 28 FOR SPECIFIC LOW VOLTAGE WIRING CONNECTIONS.

FOR PROPER VOLTAGES, SELECT THERMOSTAT WIRE (CONTROL WIRES) GAUGE PER TABLE BELOW.

WIRE RUN LENGTH	AWG#	INSULATION TYPE
LESS THAN 100' (30 METERS)	18	TEMPERATURE RATING
MORE THAN 100' (30 METERS)	16	35°C MINIMUM.

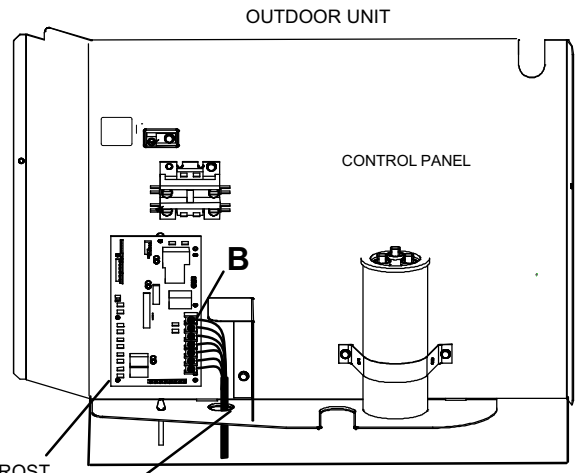

DEMAND DEFROST CONTROL

A NOTE — Wire tie provides low voltage wire strain relief and to maintain separation of field installed low and high voltage circuits.

4 ROUTE HIGH VOLTAGE AND GROUND WIRES

Any excess high voltage field wiring should be trimmed and secured away from any low voltage field wiring. To facilitate a conduit, a cutout is located in the bottom of the control panel. Connect conduit to the control panel using a proper conduit fitting.

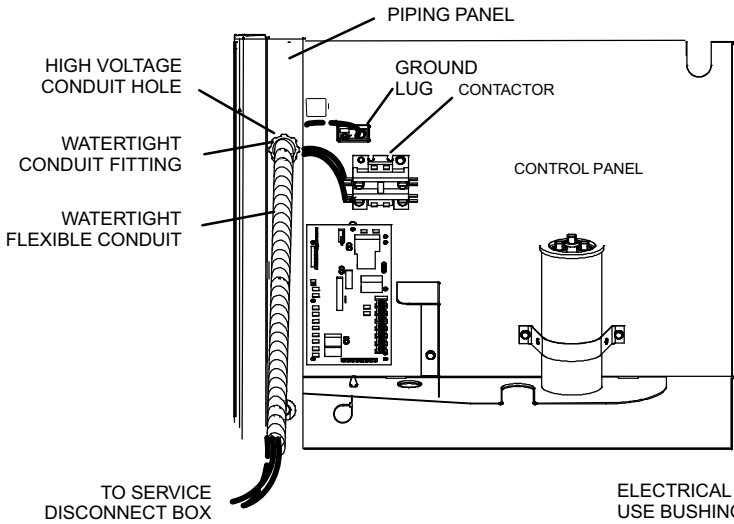

ELECTRICAL INLET (HIGH VOLTAGE)

WIRING ENTRY POINTS

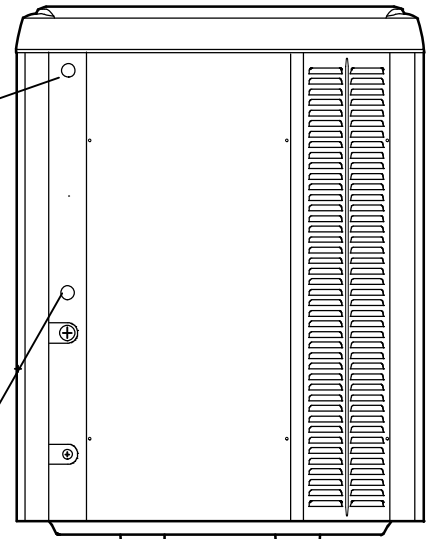

ACCESS VIEW

ELECTRICAL INLET (CONTROL WIRING — LOW VOLTAGE). USE BUSHING PROVIDED IN BAG ASSEMBLY USED HERE.

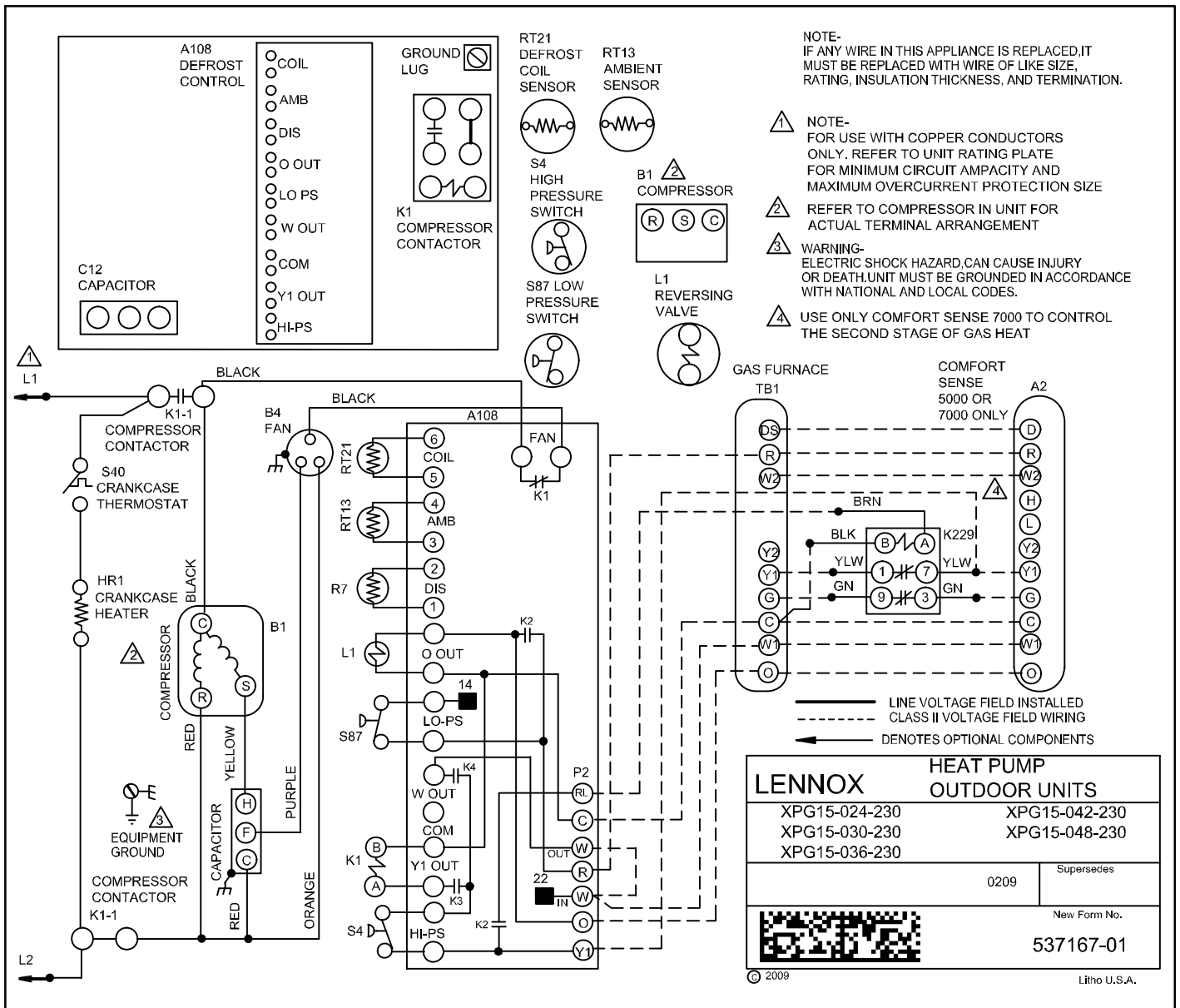

Figure 17. XPG15 (-024, -030, -036, -042 and -048) Wiring using ComfortSense® 5000/7000 Thermostats

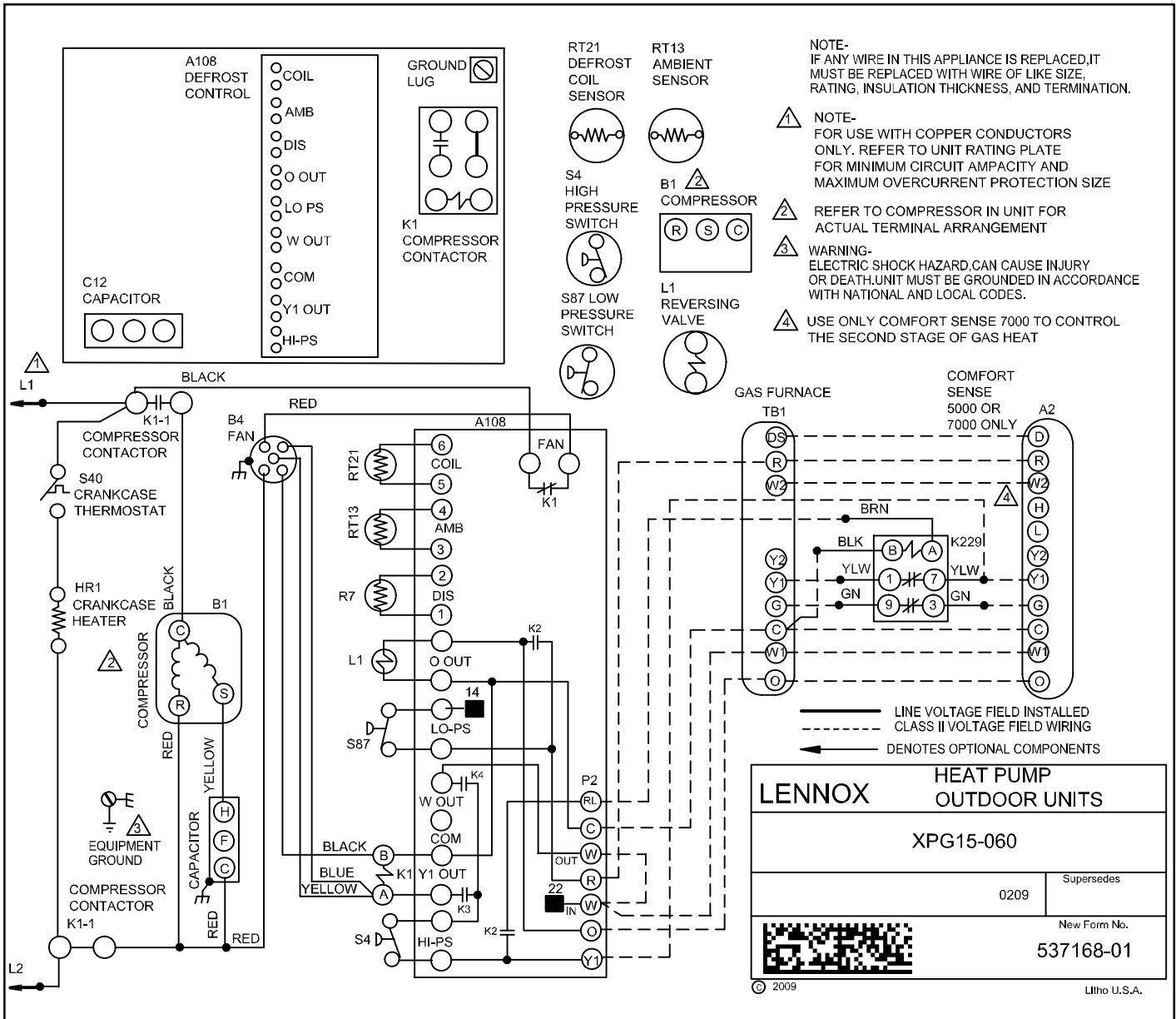

Figure 18. XPG15 (-060) Wiring using ComfortSense® 5000/7000 Thermostats

System Setup Information19

COMFORTSENSE® 7000 SETUP SELECTIONS (CATALOG# Y0349)			Checked
TAB MENU ITEM	PARAMETER	SELECTION DESCRIPTION	
OPTIONS INSTALLER SETTINGS	SYSTEM SETUP	HEAT PUMP / ELECTRIC	
	COMPRESSOR STAGES	1	
	INDOOR HEAT STAGES ⁴	1 OR 2 ¹	
	OUTDOOR SENSOR (OA) ²	NO	
	OA – LOW BALANCE POINT ³	OFF	
	OA – HIGH BALANCE POINT ³	OFF (Use down arrow to go one step below lowest set point.)	

¹ Select 1 or 2 to match number of furnace heat stages

² Outdoor sensor can be used in the display ONLY mode by setting **OUTDOOR SENSOR** to **YES** and the **LOW** and **HIGH** balance point to **OFF**.

³ If outdoor sensor is not present and user tries to select the options DISPLAY INFO -> OUTDOOR TEMP, LOW BALANCE POINT, HIGH BALANCE POINT, DEW POINT CONTROL or HUMIDITROL, "OUTDOOR SENSOR REQUIRED" message is displayed instead of scroll options for these menus.

⁴ Confirm temperature differential setting for first and second stages. Factory defaults are 1°F. See ComfortSense® 7000 Installation instructions for procedures on how to confirm temperature differential settings.

COMFORTSENSE® 5000 SETUP SELECTIONS (CATALOG# X4147)			Checked
INSTALLER SETUP #	INSTALLER SETUP NAME	SELECT	
0170	SYSTEM TYPE *	7 – Two Heat/One Cool Heat Pump – Heat pump with auxiliary or back-up heat.	
0200	AUXILIARY HEAT SOURCE**	0 – Electric Heat is used as auxiliary heat source in heat pump application. (Factory setting) (DO NOT USE FOSSIL FUEL SETTING)	
0340	REMOTE OUTDOOR TEMPERATURE SENSOR	0 – No remote outdoor temperature sensor. or 1 – Outdoor temperature sensor used for display ONLY	

* Use **W2** staged time feature for two-stage furnaces with ComfortSense® 5000.

** Confirm cycle per hour rate settings per stage settings. See ComfortSense® 5000 Installation instructions for procedures on how to confirm cycle rate.

IMPORTANT — Do not use **Y2** for furnace gas heat

FURNACE SETUP SELECTIONS		Checked
Item #	Task	
1	Integrated control must allow gas furnace operation with W and O input. *	
2	Integrated control with the W951 link (link from R to 0) must be cut. **	

*Integrated control with catalog # 23W25 [and 19W60 after date code 0710 (revision 1.11)] will accept both inputs. See Service and Application Note H-06-6)

**When W951 link is cut, cooling blower profiles will be disabled in the heat pump heating mode

XPG15 SETUP SELECTIONS		Checked
Item #	Task	
1	Verify proper coil sensor location and all Demand Defrost Control jumper pin positions	

NOTE — Demand defrost control will not output a **W** out when outdoor temperatures are above 65°F (18°C).

STEP 1 — FIELD WIRING

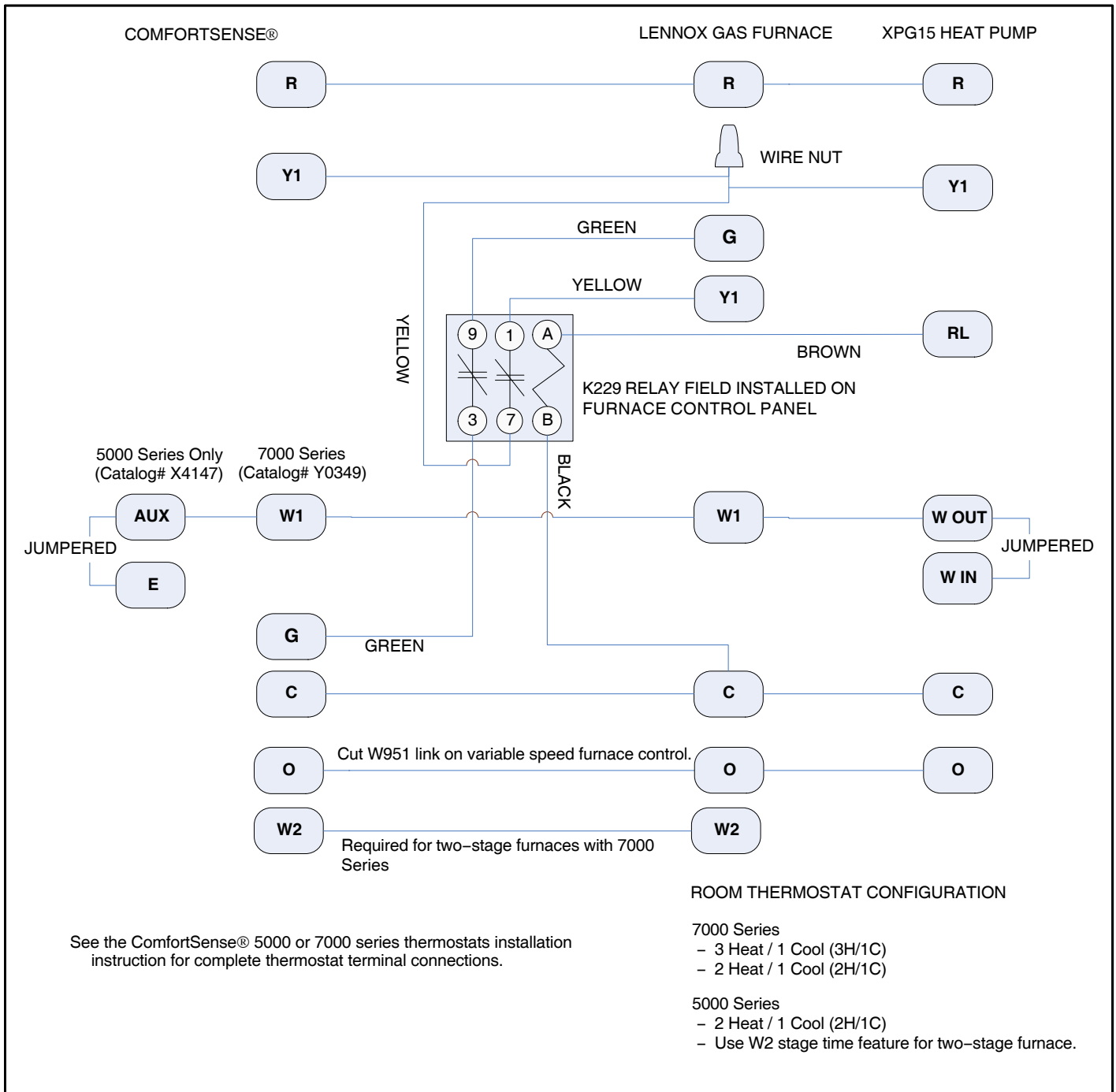

Figure 19. ComfortSense® 5000/7000 Series Room Thermostat Connections

STEP 2 — ROOM THERMOSTAT SETUP

COMFORTSENSE® 5000

Required settings for XPG15 dual-fuel applications.

Use the following steps and the Installer Setup menu to match the thermostat to the HVAC system.

1. Press and release the **SYSTEM** key.
2. Press and hold the two blank keys on either side of the center blank key for approximately five seconds.

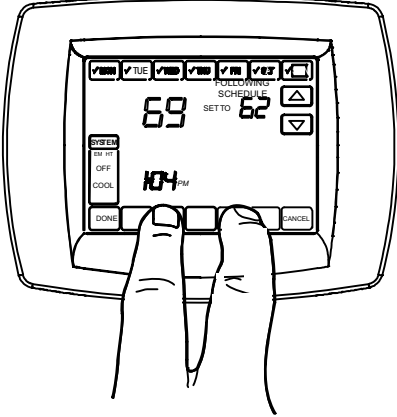

3. Release the two keys when the thermostat display matches the display below.

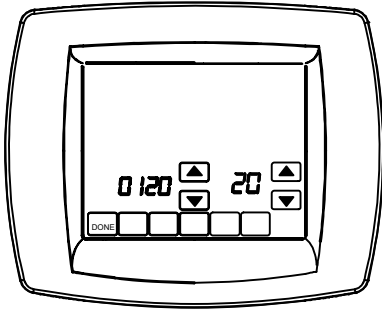

4. Refer to the following figure to see how the thermostat keys are used to make selections from the setup menu.

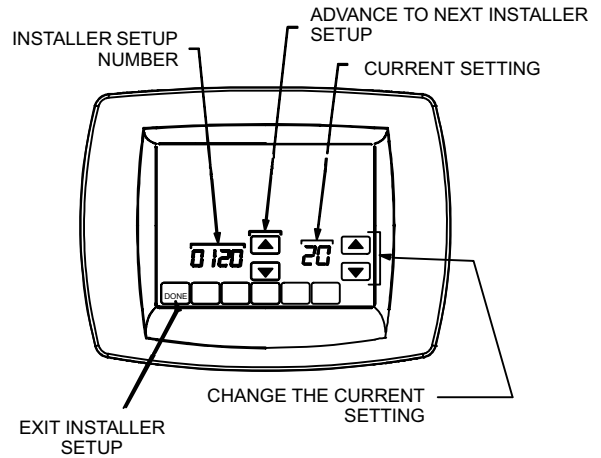

5. The installer setup number is displayed on the left-hand side of the screen. The current installer set-up number is displayed on the right-hand side of the screen. Use the up and down arrows on the right-hand side of the display to select the proper setting for that particular set-up number.
6. After the proper selection has been made as exemplified in table 4, use the up arrow in the center of the thermostat to advance to the next setup screen.
7. When all setup selections have been made, press the **DONE** key to save your settings. Thermostat display will return to the main screen.

NOTE — Press and release the **SYSTEM** key, then press and hold the center blank key to access the user setup screens. The user setup options are limited to those features that would be used by the homeowner. Press the **DONE** key when finished.

Table 4. ComfortSense® 5000 Setup Selections

Installer Setup Number	Installer Setup Name	Select
0170	System Type	7 — Two Heat / One Cool Heat Pump -- Heat pump with auxiliary or back-up heat.
0200	Auxiliary Heat Source	0 — Electric heat is used as auxiliary heat source in heat pump application. Factory setting. DO NOT SELECT FOSSIL FUEL.
0340	Remote Outdoor Temperature Sensor	0 — No remote outdoor temperature sensor. or 1 — Outdoor temperature sensor used for display only.

COMFORTSENSE® 7000

Required settings for XPG15 dual-fuel applications.

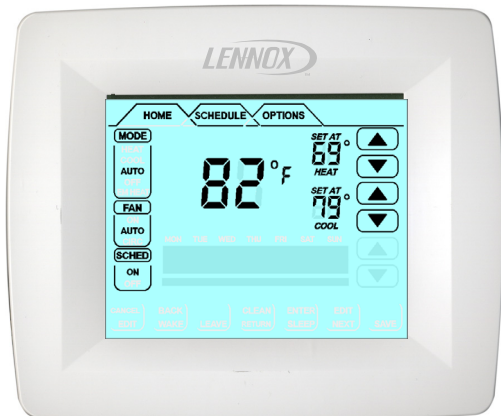

INSTALLER SETTINGS

[OPTIONS TAB > INSTALLER SETTINGS > [ENTER] [ENTER]]

Press **OPTIONS** tab, then use the arrows to select **INSTALLER SETTINGS**. Press **ENTER** twice.

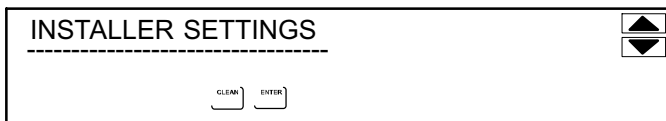

NOTE — After **ENTER** is pressed the first time, a note states “MUST BE SET BY QUALIFIED PERSON”. Press **ENTER** again to access installer settings.

Use the following procedure to set up thermostat for use with the XPG15.

SYSTEM SETUP

Set the thermostat for heat pump operation and define the number of compressor stages and the number of backup heat stages. The default settings for the system are Heat Pump, Electric, 1 or 2 compressor stages and 1 or 2 indoor heat stages.

1. For **HEAT PUMP**, use arrows to select **ELECTRIC**; then press **SAVE**.

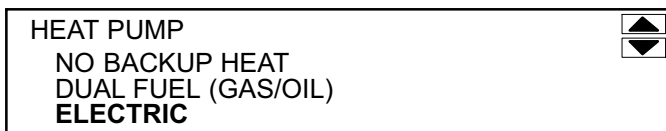

2. For **COMPRESSOR STAGES**, use arrows to select **1** compressor stage; then press **SAVE**.

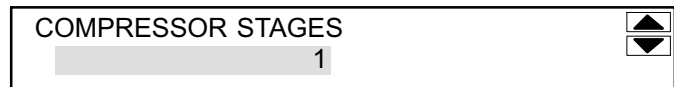

3. For **INDOOR HEAT STAGES**, use arrows to select **1** or **2** indoor heat stages; then press **SAVE**.

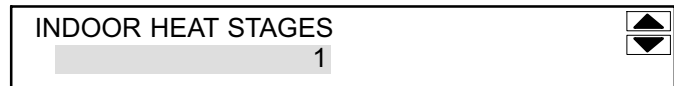

4. **OUTDOOR SENSOR** — Default is **NO**. Balance Points, Humiditrol, Dew Point Control require an outdoor sensor. This control sets the thermostat to test for and report outdoor temperature. Scroll to **OUTDOOR SENSOR** and press **ENTER**; use arrows to select **NO**; press **SAVE**.

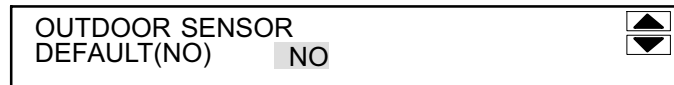

If outdoor sensor is used, select **LOW** and **HIGH** balance points to the **OFF** option as follows:

LOW BALANCE POINT — Default 25°F (heat pump only, and if outdoor sensor installed). If outdoor temperature is below programmed low balance point, compressor heating is not allowed. The options are **OFF** or any point from -40°F to the High Balance Point setting in 1.0°F steps.

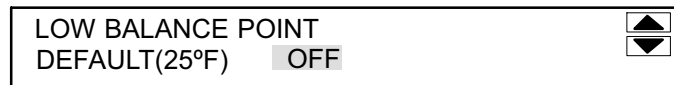

HIGH BALANCE POINT — Default is 50°F (heat pump only, and if outdoor sensor installed). If outdoor temperature is above the high balance point, then auxiliary heat is not allowed. The options are **OFF** or any point from the Low Balance Point up to 75°F in 1.0°F steps.

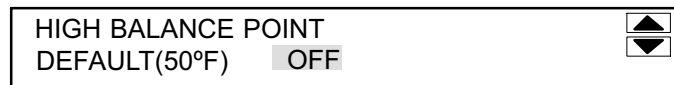

NOTE — If outdoor sensor is not present and user tries to select the options **DISPLAY INFO -> OUTDOOR TEMP**, **LOW BALANCE POINT**, **HIGH BALANCE POINT**, **DEW POINT CONTROL** or **HUMIDITROL**, “**OUTDOOR SENSOR REQUIRED**” message is displayed instead of scroll options for these menus.

Table 5. ComfortSense® 7000 Setup Selections

Tab Menu Item	Parameter	Selection Description
OPTIONS INSTALLER SETTINGS	SYSTEM SETUP	HEAT PUMP ELECTRIC
	COMPRESSOR STAGES	1
	INDOOR HEAT STAGES	1 OR 2 *
	OUTDOOR SENSOR**	NO
	OUTDOOR SENSOR - LOW	OFF
	OUTDOOR SENSOR - HIGH	(Use down arrow to go one step below lowest set point.)

* Select 1 or 2 to match number of furnace heat stages.

** A ComfortSense 7000 outdoor sensor is not needed for use with XPG15. If a sensor is used (to display outdoor temperature at thermostat) set **OUTDOOR SENSOR** to **YES** and set **LOW** and **HIGH** to **OFF**.

STEP 3 — SYSTEM OPERATION CHECKS

The following table illustrates which terminals should have 24VAC inputs or outputs during certain operation modes. (Example: In the cooling mode, there should be 24VAC between Y1 and C on the Demand Defrost Control terminal strip).

Operation Mode	ComfortSense®							Gas Furnace						Dedicated Heat Pump (XPG15)					
	Y1	W1	W2	O	G	E	L	Y1	Y2	W1	W2	G	O	Y1	W IN	RL/ K229	O	Y1 OUT	W OUT
Cooling Mode																			
OFF				X													X		
Cooling	X			X	X			X				X	X	X			X	X	
Heating Mode (Outside Temperature above 32°F)																			
First Stage Heating (Heat Pump)	X				X			X				X		X				X	
Second Stage Heating (First Stage Gas Heat)	X	X			X					X			X	X	X	X	X		X
Third Stage Heating (Second Stage Gas Heat)	X	X	X		X					X	X		X	X	X	X	X		X
Heating Mode (Outside Temperature below 32°F)																			
First Stage Heating (First Stage Gas Heat)	X				X					X			X	X	X	X	X		X
Second Stage Heating (Second Stage Gas Heat)	X	X	X		X					X	X			X	X	X	X		X
Defrost Mode																			
Power Defrost	X				X								X	X		X	X	X	
Natural Defrost	X				X								X	X		X	X		
Emergency Heat Mode																			
Emergency Heat Mode		X			X	X				X		X			X				X
Low and High Pressure (Lock-Out Mode)																			
Cooling LPS, HPS	X			X	X			X				X	X	X			X		
Heating HPS	X				X			X				X		X					
Heating LPS	X				X					X			X	X	X	X	X		X

IMPORTANT — Set-up is critical to ensure proper system operation. Refer to installation instructions packaged with the unit, as well as XPG15 service manual. Both documents are available from www.LennoxDaveNet.net.

Field-Installed Relay — K229 - De-energizes **Y1** and **G** inputs to furnace (factory-provided and field-installed at indoor unit).

NOTES —

- For proper operation the Demand Defrost Control must have 24VAC between **R** (system power input) and **C** (system common). The above chart shows which terminals should have 24VAC inputs or outputs during certain operation modes. (Example: In the cooling mode, there should be 24VAC between **Y1** and **C** on the Demand Defrost Control terminal strip).
- Placing a jumper on the Demand Defrost Control's TEST pins will not activate the heat pump out of inactive mode. (24VAC power must be cycled to the Demand Defrost Control to activate the heat pump out of inactive mode) .
- Demand defrost control will not output a **W** out signal when the outdoor temperature is above 65°F (18°C).
- If the Demand Defrost Control enters a low pressure LOCKOUT during heating mode, the outdoor unit will enter the heat pump inactive mode. The Demand Defrost Control will flash the low pressure code. If the room thermostat calls for Y1 heating in low pressure LOCKOUT, the Demand Defrost Control will alternately display two codes — four (4) seconds for the low pressure LOCKOUT, and then four (4) seconds heat pump inactive - gas mode active code.

Servicing Units Delivered Void of Charge²⁰

If the outdoor unit is void of refrigerant, clean the system using the procedure described below.

1. Use nitrogen to pressurize the system and check for leaks. Repair all leaks.
2. Evacuate the system to remove as much of the moisture as possible.
3. Use nitrogen to break the vacuum and install a new filter drier in the system.
4. Evacuate the system again.
5. Use figure 22 to charge the system.
6. Monitor the system to determine the amount of moisture remaining in the oil. It may be necessary to replace the filter drier several times to achieve the required dryness level. **If system dryness is not verified, the compressor will fail in the future.**

Unit Start-Up²¹

⚠ IMPORTANT

If unit is equipped with a crankcase heater, it should be energized 24 hours before unit start-up to prevent compressor damage as a result of slugging.

1. Rotate fan to check for binding.

2. Inspect all factory- and field-installed wiring for loose connections.
3. After evacuation of the line set and indoor coil is complete, open both the liquid and vapor line service valves to release the refrigerant charge contained in outdoor unit into the system.
4. Replace the stem caps and tighten as specified in *Operating Gauge Set and Service Valves* on page 8.
5. Check voltage supply at the disconnect switch. The voltage must be within the range listed on the unit's nameplate. If not, do not start the equipment until you have consulted with the power company and the voltage condition has been corrected.
6. Set the thermostat for a cooling demand. Turn on power to the indoor unit and close the outdoor unit disconnect switch to start the unit.
7. Recheck voltage while the unit is running. Power must be within range shown on the nameplate.
8. Check system for sufficient refrigerant by using the procedures listed under *System Charge*.

System Charge²²

This section outlines procedures for:

- Connecting gauge set for testing and charging;
- Adding or removing refrigerant.

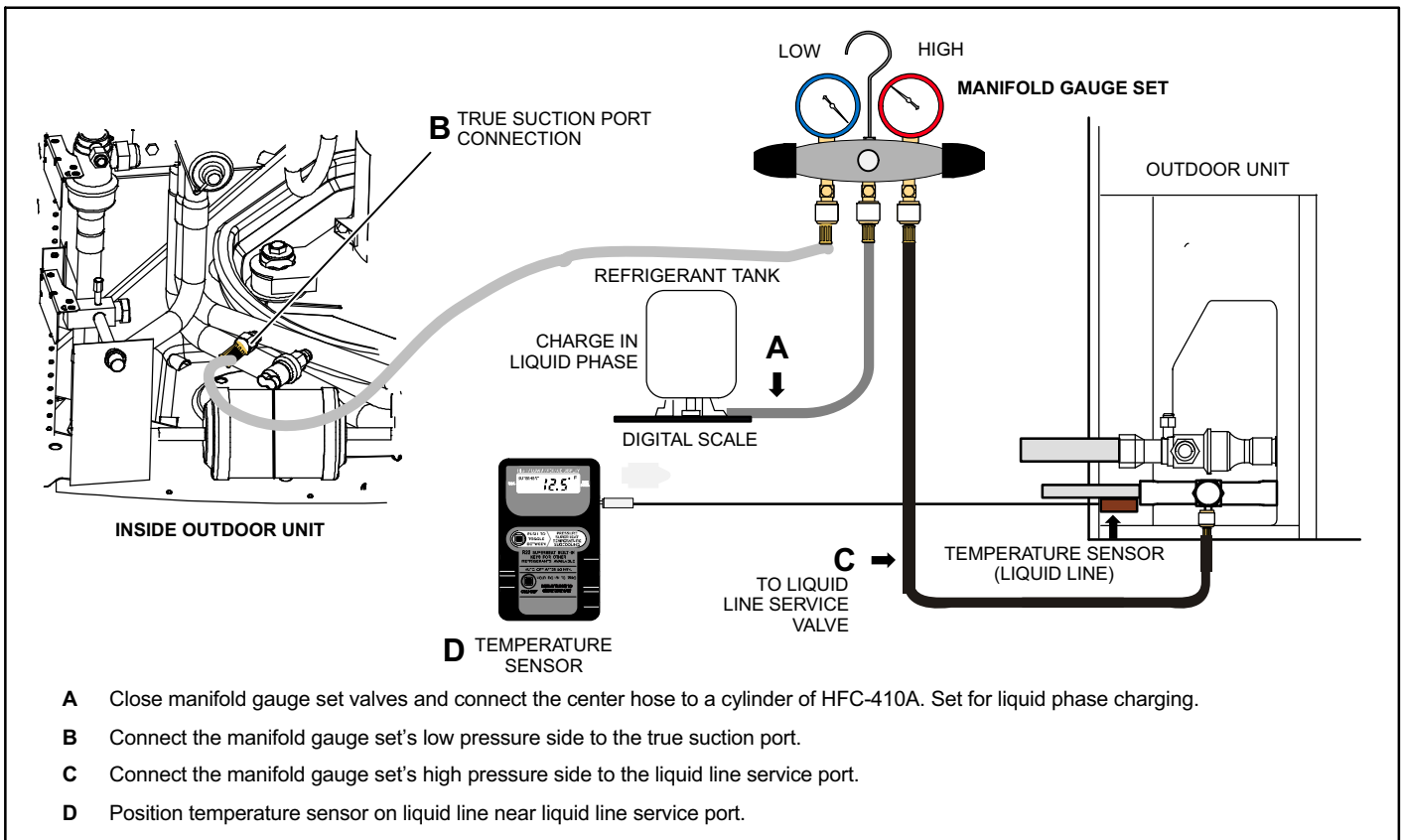

Figure 20. Gauge Set Connection

ADDING OR REMOVING REFRIGERANT

This system uses HFC-410A refrigerant which operates at much higher pressures than HCFC-22. The pre-installed liquid line filter drier is approved for use with HFC-410A only. Do not replace it with components designed for use with HCFC-22. This unit is NOT approved for use with coils which use capillary tubes or fixed orifices as a refrigerant metering device. Check airflow using static pressure reading as defined in figure 21.

AIRFLOW

INDOOR COIL

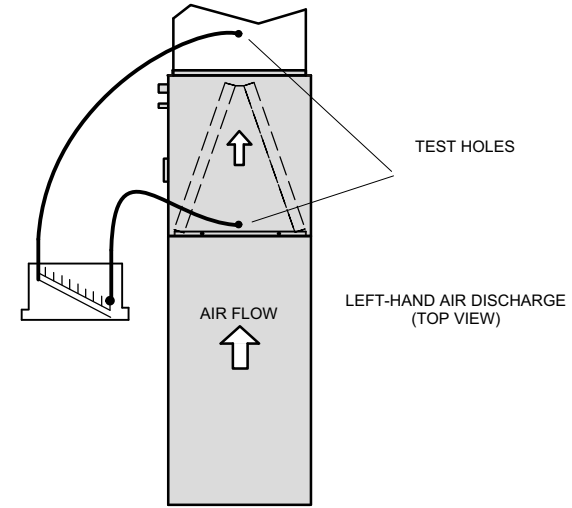

TEST HOLES

LEFT-HAND AIR DISCHARGE (TOP VIEW)

AIR FLOW

CAUTION — Take care when drilling test holes in the furnace flange and the duct. Drill holes away from refrigerant piping. Test holes should be drilled where specified in order to avoid unit damage.

Proper air volume must be provided over the evaporator coil. Select a blower motor speed tap that will provide 400 ± 50 CFM per 12,000 Btuh of cooling capacity (wet coil). A static pressure reading must be taken to see if the pressure drop falls within the proper range.

To ensure accuracy, air must be read from below the coil and above the coil. See illustration to the left for an example on how to obtain an accurate reading.

1. Drill one 5/16" (8 mm) air test hole into the delta plate between the coil slabs.
2. Drill one 5/16" (8 mm) air test hole into the duct above the top of the coil.
3. Connect the **instrument for static pressure measurement hoses** to the air entering side of coil. Insert the hoses so that 1/4" (6 mm) extends inside the duct or end seal. Seal around holes with Permagum.
4. Turn on electrical power to the furnace and set the thermostat to initiate a cooling demand.
5. Refer to indoor coil installation instruction for range of air volumes and equivalent static pressure readings for these units. Observe the static pressure reading. If the reading is below the required air volume, increase the blower speed; if the reading is above the required air volume, decrease the blower speed. Refer to the furnace wiring diagram for blower speed settings.
6. When the required static pressure readings are obtained, remove the test hose lines and insert snaphole plugs into test holes.

Figure 21. Checking Indoor Airflow over Evaporator Coil using Static Pressure Reading

Use **WEIGH IN** to initially charge a system when the outdoor unit is void of charge. To verify charge and add or remove refrigerant use the **SUBCOOLING** method.

WEIGH IN

CHARGING METHOD

CALCULATING SYSTEM REFRIGERANT CHARGE WHEN OUTDOOR UNIT IS VOID OF REFRIGERANT

If the system is void of refrigerant, first, locate and repair any leaks and then weigh in the refrigerant charge into the unit. To calculate the total refrigerant charge:

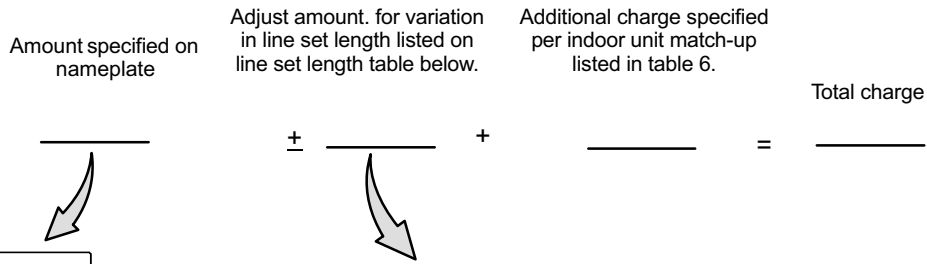

LENNOX	
DALLAS, TEXAS	
M/N TSA036H4N41G	
S/N PPYYMNNNNN	
CONTAINS HFC-410A	DESIGN PRESSURE
FACTORY CHARGE	HI 446 PSIG
8 LBS 9 OZS	LO 236 PSIG
ELECTRICAL RATING	
NOMINAL VOLTS: 460	
3 PH	60 HZ
MIN 414	MAX 506
COMPRESSOR	
FAN MOTOR	
PH	3
PH	1
FLA	5.64
FLA	0.6
LRA	36.0
HP	1/6
MAX CURRENT (Amps)	7.65
MAX FUSE OR CIR. BRK. (AMPS)	15
FUSE/CIRCUIT BREAKER (Amps) (SHARPER/REC)	
PPYYMNNNNN	
UL LISTED 250V CONDENSER UNIT	
FOR OUTDOOR USE	

Refrigerant Charge per Line Set Length

Liquid Line Set Diameter	Ounces per 5 feet (g per 1.5 m) adjust from 15 feet (4.6 m) line set*
3/8" (9.5 mm)	3 ounce per 5' (85 g per 1.5 m)

*If line length is greater than 15 ft. (4.6 m), add this amount. If line length is less than 15 ft. (4.6 m), subtract this amount.

NOTE — Insulate liquid line when it is routed through areas where the surrounding ambient temperature could become higher than the temperature of the liquid line or when pressure drop is equal to or greater than 20 psig.

NOTE — The above nameplate is for illustration purposes only. Go to actual nameplate on outdoor unit for charge information.

Figure 22. Using HFC-410A Weigh In Method

SUBCOOLING

TEST AND CHARGING METHOD

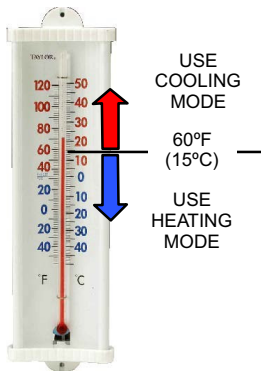

SAT° _____
 LIQ° - _____
 SC° = _____

1. Measure outdoor ambient temperature; determine whether to use **cooling mode** or **heating mode** to check charge.
2. Determine whether you will be using cooling or heating mode, and connect gauge set for the required mode as illustrated in figure 20.
3. Check liquid and vapor line pressures. Compare pressures with either heat or cooling mode normal operating pressures in table 7, *Normal Operating Pressures*.

NOTE — The reference table is a general guide. Expect minor pressure variations. Significant differences may mean improper charge or other system problem.

4. Set thermostat for heat/cool demand, depending on mode being used:

USING COOLING MODE — When the outdoor ambient temperature is 60°F (15°C) and above. Target subcooling values in table 6 are based on 70 to 80°F (21-27°C) indoor return air temperature; if necessary, operate heating to reach that temperature range; then set thermostat cooling mode setpoint to 68°F (20°C). When pressures have stabilized, continue with Step 5.

USING HEATING MODE — When the outdoor ambient temperature is below 60°F (15°C). Target subcooling values in table 6 are based on 65-75°F (18-24°C) indoor return air temperature; if necessary, operate cooling to reach that temperature range; then set thermostat heating mode setpoint to 77°F (25°C). When pressures have stabilized, continue with Step 5.

5. Read the liquid line temperature; record in the LIQ° space.
6. Read the liquid line pressure; then find its corresponding temperature in the temperature/ pressure chart listed in table 8 and record it in the SAT° space.
7. Subtract LIQ° temperature from SAT° temperature to determine subcooling; record it in SC° space.
8. Compare SC° results with table 6, being sure to note any additional charge for line set and/or match-up.
9. If subcooling value is greater than shown in table 6 for the applicable unit, remove refrigerant; if less than shown, add refrigerant.
10. If refrigerant is added or removed, repeat steps 4 through 5 to verify charge.
11. Disconnect gauge set and re-install both the liquid and vapor service valve caps.

NOTE — Insulate liquid line when it is routed through areas where the surrounding ambient temperature could become higher than the temperature of the liquid line or when pressure drop is equal to or greater than 20 psig.

Figure 23. Using HFC-410A Subcooling Method

Indoor Coil Matchups²³

Target subcooling and charging values for approved indoor coil match-ups.

⚠ IMPORTANT

This unit must be matched with an indoor coil as specified in this section, or with Lennox Engineering Handbook. Coils previously charged with HCFC-22 must be flushed.

Table 6. Indoor Coil Matchups and Target Subcooling

Model Number	XPG15-024				XPG15-030				XPG15-036			
	Add Charge*		Target SC		Add Charge*		Target SC		Add Charge*		Target SC	
	lb	oz	Heat	Cool	lb	oz	Heat	Cool	lb	oz	Heat	Cool
CH33-31	0	0	21	4	0	0	23	4	0	0	22	4
CH33-42	1	4	18	4	0	2	20	3	0	5	15	4
CH33-43	1	4	13	4	1	8	16	4	0	11	13	4
CH33-44/48B	1	4	13	4	1	8	16	4	0	11	13	4
CH33-48C									0	11	13	4
CH33-49C									1	5	10	8
CR33-48	1	4	18	4	0	2	20	3	0	5	15	4
CX34-31	0	0	21	4	0	0	23	4	0	0	22	4
CX34-38	1	4	18	4	0	2	20	3	0	5	15	4
CX34-43	1	4	13	4	1	8	16	4	0	11	13	4
CX34-44/48B					0	2	14	3	0	5	15	4
CX34-49					2	5	11	7	1	5	10	8
CX34-50/60C					1	8	16	4	0	11	13	4

Model Number	XPG15-042				XPG15-048				XPG15-060			
	Add Charge*		Target SC		Add Charge*		Target SC		Add Charge*		Target SC	
	lb	oz	Heat	Cool	lb	oz	Heat	Cool	lb	oz	Heat	Cool
CH33-43	0	5	17	5								
CH33-44/48B	0	5	17	5								
CH33-48C	0	5	17	5								
CH33-49C	1	7	11	7	0	0	17	6	0	11	20	6
CH33-60D					0	6	21	4	0	0	25	4
CH33-62D					1	5	14	6	1	0	18	6
CR33-48	0	0	15	5								
CR33-50/60	1	7	11	6	0	0	45	2	-1	-8	45	2
CR33-60D	1	7	11	6	0	0	45	2	-1	-8	45	2
CX34-38	0	0	15	5								
CX34-43	0	5	17	5								
CX34-44/48B	0	0	27	3								
CX34-49	1	7	11	7	0	0	17	6	0	11	20	6
CX34-60D	0	9	9	4	0	6	21	4	0	0	25	4
CX34-62C	1	5	7	4	1	5	14	6	0	0	14	6
CX34-62D	1	5	7	4	1	5	14	6	1	0	18	6

**Amount of charge required in addition to charge shown on unit nameplate. Remember to consider line set length difference.

Operating and Temperature Pressures²⁴

Minor variations in these pressures may be expected due to differences in installations. Significant differences could mean that the system is not properly charged or that a problem exists with some component in the system.

Table 7. Normal Operating Pressure - Liquid ± 10 and Vapor ± 5 PSIG*

°F (°C)**	XP-024		XP-030		XP-036		XP-042		XP-048		XP-060	
	Liquid	Vapor	Liquid	Vapor	Liquid	Vapor	Liquid	Vapor	Liquid	Vapor	Liquid	Vapor
HEATING MODE												
20 (-7.0)	292	65	323	61	302	61	281	61	324	62	327	60
30 (-1.0)	305	77	339	71	321	72	292	73	336	74	345	72
40 (4.4)	336	94	367	85	341	84	308	88	360	90	365	87
50 (10.0)	366	111	403	105	365	105	328	106	391	107	396	102
60 (15.5)	397	129	432	123	389	123	345	123	422	122	425	117
COOLING MODE												
65 (18.3)	234	142	243	130	254	134	237	140	240	125	245	132
70 (21.1)	251	143	262	133	273	136	255	141	259	129	263	133
75 (23.9)	270	144	282	136	294	136	272	143	278	134	284	134
80 (26.6)	292	145	304	139	317	136	293	144	300	137	306	136
85 (29.4)	313	146	326	140	340	138	316	145	321	139	329	138
90 (32.2)	336	148	350	142	364	139	339	146	345	141	354	139
95 (35.0)	360	149	374	143	388	141	364	146	370	140	380	141
100 (37.7)	383	150	399	144	414	142	389	148	396	142	405	142
105 (40.6)	409	151	426	145	442	143	416	149	422	143	432	143
110 (43.3)	439	152	453	146	468	147	444	150	451	145	459	145
115 (46.1)	469	152	483	148	501	149	479	152	482	148	492	147

*These are most popular match-up pressures. Indoor match-up, indoor air quality, and indoor load cause pressures to vary.

**Temperature of the air entering the outdoor coil.

Table 8. HFC-410A Temp. (°F) - Pressure (Psig)

°F	Psig	°F	Psig	°F	Psig	°F	Psig	°F	Psig
32	100.8	56	158.2	79	231.6	103	331.0	127	457.6
33	102.9	57	161.0	80	235.3	104	335.7	128	463.5
34	105.0	58	163.9	81	239.0	105	340.5	129	469.5
35	107.1	59	166.7	82	242.7	106	345.3	130	475.6
36	109.2	60	169.6	83	246.5	107	350.1	131	481.6
37	111.4	61	172.6	84	250.3	108	355.0	132	487.8
38	113.6	62	175.4	85	254.1	109	360.0	133	494.0
39	115.8	56	158.2	86	258.0	110	365.0	134	500.2
40	118.0	63	178.5	87	262.0	111	370.0	135	506.5
41	120.3	64	181.6	88	266.0	112	375.1	136	512.9
42	122.6	65	184.3	89	270.0	113	380.2	137	519.3
43	125.0	66	187.7	90	274.1	114	385.4	138	525.8
44	127.3	67	190.9	91	278.2	115	390.7	139	532.4
45	129.7	68	194.1	92	282.3	116	396.0	140	539.0
46	132.2	69	197.3	93	286.5	117	401.3	141	545.6
47	134.6	70	200.6	94	290.8	118	406.7	142	552.3
48	137.1	71	203.9	95	295.1	119	412.2	143	559.1
49	139.6	72	207.2	96	299.4	120	417.7	144	565.9
50	142.2	73	210.6	97	303.8	121	423.2	145	572.8
51	144.8	74	214.0	98	308.2	122	428.8	146	579.8
52	147.4	75	217.4	99	312.7	123	434.5	147	586.8
53	150.1	76	220.9	100	317.2	124	440.2	148	593.8
54	152.8	77	224.4	101	321.8	125	445.9	149	601.0
55	155.5	78	228.0	102	326.4	126	451.8	150	608.1

System Operations²⁵

The outdoor unit and indoor blower cycle on demand from the room thermostat. When the thermostat blower switch is in the **ON** position, the indoor blower operates continuously.

1. ROOM THERMOSTAT EMERGENCY HEAT FUNCTION

ComfortSense[®] 5000 and 7000 thermostats have an emergency heat function. This feature is applicable when isolation of the outdoor unit is required.

Emergency heat is usually used during an outdoor unit shutdown, but it should also be used following a power outage if power has been off for over an hour and the outdoor temperature is below 50°F (10°C). The system should be left in the emergency heat mode at least six hours to allow the crankcase heater sufficient time to prevent compressor slugging.

2. FILTER DRIER

The unit is equipped with a large-capacity biflow filter drier which keeps the system clean and dry. If replacement is necessary, order another of like design and capacity.

Defrost System²⁶

The Demand Defrost Control provides a demand defrost algorithm, field-selectable defrost termination temperatures, compressor anti-short-cycle timing, and internal switching of outputs. Additionally, the software provides a inactive mode that shuts the heat pump off when icing conditions are detected and when second-stage heating (gas heat) is desired.

The Demand Defrost Control monitors ambient temperature, outdoor coil temperature and total run time to determine when a power or natural defrost cycle is required. The coil temperature probe has a spring clip to allow mounting to the outside coil tubing. The location of the coil sensor is important for proper defrost operation. See figure 1 for proper coil sensor location.

1. DIAGNOSTIC LIGHT-EMITTING DIODES

The state (Off, On, Flashing) of two light-emitting diodes on the Demand Defrost Control [DS1 (Red) and DS2 (Green)] indicate diagnostic conditions that are described in table 10.

2. DEMAND DEFROST CONTROL PRESSURE SWITCH CONNECTIONS

The unit's pressure switches (LO PS - S87 and HI PS - S4) are factory-wired into the Demand Defrost Control on the LO-PS and HI-PS terminals, respectively.

Low Pressure Switch (LO-PS) —When the low pressure switch trips, the Demand Defrost Control will cycle off the compressor, and the strike counter in the Demand Defrost Control will count one strike. The low pressure switch is ignored under the following conditions:

- During the defrost cycle and 90 seconds after the termination of defrost.
- For 90 seconds following the compressor start-up.
- During **TEST** mode.

High Pressure Switch (HI-PS)—When the high pressure switch trips, the Demand Defrost Control will cycle off the compressor, and the strike counter in the Demand Defrost Control will count one strike.

3. DEMAND DEFROST CONTROL PRESSURE SWITCH EVENT SETTINGS

The following pressures are the auto reset event value triggers for low and high pressure thresholds:

- **High Pressure** (auto reset) - trip at 590 psig; reset at 418.
- **Low Pressure** (auto reset) - trip at 25 psig; reset at 40.

4. FIVE-STRIKE LOCKOUT SAFETY FUNCTION

The five-strike lockout safety function is designed to protect the unit's compressor from damage. The Demand Defrost Control looks for 24VAC on its **Y1** terminal. When the **Y1** input detects 24VAC, the Demand Defrost Control internal control logic will do the following:

- Count any HI-PS and LO-PS pressure switch trips (open and close). Individual HI-PS and LO-PS trips are totaled by the Demand Defrost Control.
- Up to four pressure switch trips are allowed in a single thermostat demand without locking out the Demand Defrost Control. If the thermostat demand is satisfied before a fifth pressure switch trip, the control will reset the five-strike counter to zero.
- If either pressure switch opens for a fifth time during a single **Y1** demand, the Demand Defrost Control will enter a lockout condition.

The system will require servicing to determine the cause of the pressure switch condition. Once the condition has been rectified, power to the Demand Defrost Control's **R** terminal must be cycled OFF, or jumper placed on the TEST pins between 1 to 2 seconds to reset the Demand Defrost Control.

DEMAND DEFROST CONTROL BOARD — A108
PART #102151-01 / CATALOG# 47W47

NOTE — Component locations may vary by board manufacturer.

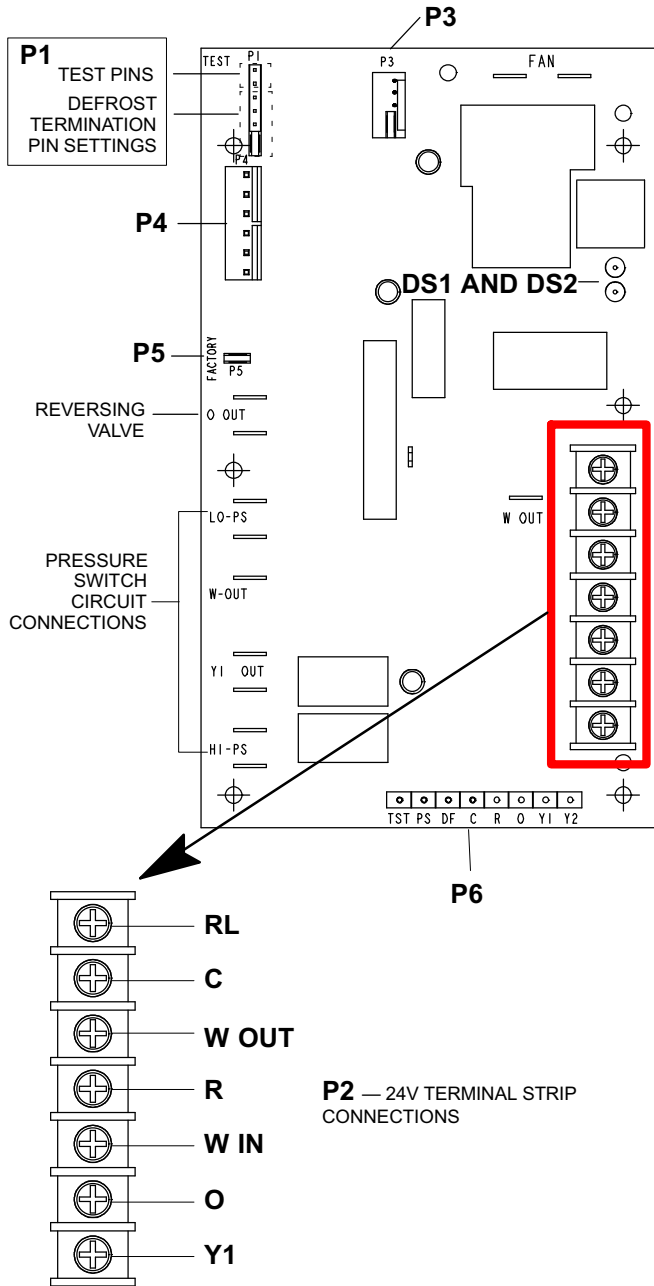

DIAGNOSTIC LIGHT-EMITTING DIODES

Diagnostic light-emitting diode descriptions are listed in table 10.

Table 9. Demand Defrost Control — A108
Inputs/Outputs and Jumper Settings

ID	Description	
O OUT	24VAC output connection for reversing valve.	
LO-PS	Connection for low-pressure switch	
W-OUT	24VAC output for second-stage (gas heat) furnace connection	
Y1	24VAC common output, switched to enable compressor contactor.	
H1-PS	Connection for high-pressure switch.	
FAN	240 VAC line voltage connection for condenser fan.	
P1	50	Defrost Termination Settings: Seven position square pin header. The defrost termination temperature is measured by the defrost coil sensor. The jumper termination pin is factory set at 50°F (10°C). If the temperature jumper is not installed, the default termination temperature is 90°F (32°C).
	70	
	90	
	100	
P2	RL	24VAC output for external K229 relay to control blower operation during defrost, heat pump inactive mode, and a call for second-stage (gas heat) furnace operations.
	C	24VAC system common
	W Out	24VAC output to furnace control to begin furnace heating operation.
	R	24VAC system power input
	W In	24VAC thermostat input for second stage (gas heat) furnace operation
	O	24VAC thermostat input for reversing valve operation
	Y1	24VAC thermostat input for first-stage compressor operation
P3	Not used.	
P4	Six position square pin header. P4 provides connections for the temperature sensors.	
	COIL (BROWN)	(PIN 1) Ground connection for outdoor coil temperature sensor. (PIN 2) Connection for outdoor coil temperature sensor.
	AMB (BLACK)	(PIN 3) Ground connection for outdoor ambient temperature sensor. (PIN 4) Connection for outdoor ambient temperature sensor.
	DIS (YELLOW)	(PIN 5 and PIN 6) Harness resistor fault — 10K resistor. 10K resistor built into wiring harness connected to the DIS connector.
P5	For factory test.	
P6	Eight-position header. Provides connections for the factory test.	

5. DEMAND DEFROST CONTROL DIAGNOSTICS

See table 10 to determine Demand Defrost Control operational conditions and to diagnose cause and solution to problems.

Table 10. Demand Defrost Control Diagnostic Light-Emitting Diodes

DS2 Green	DS1 Red	Condition/Code	Possible Cause(s)	Solution
OFF	OFF	Power problem	No power (24VAC) to Demand Defrost Control terminals R and C or Demand Defrost Control failure.	¹ Check Demand Defrost Control transformer power (24VAC). ² If power is available to Demand Defrost Control and light-emitting diode(s) do not light, replace Demand Defrost Control.
Simultaneous Slow Flash		Normal operation	Unit operating normally or in standby mode.	None required.
Alternating Slow Flash		5-minute anti-short cycle delay	Initial power up, safety trip, end of room thermostat demand.	None required (place a jumper on TEST pins to override).
Simultaneous FAST Flash		Ambient Sensor Problem	Sensor being detected open or shorted or out of temperature range. Board will revert to time/temperature defrost operation. (System will still heat or cool).	
Alternating Fast Flash		Coil Sensor Problem	Sensor being detected open or shorted or out of temperature range. Board will not perform demand or time/temperature defrost operation. (System will still heat or cool).	
ON	ON	Circuit Board Failure	Indicates that Demand Defrost Control has internal component failure. Cycle 24VAC power to Demand Defrost Control. If code does not clear, replace Demand Defrost Control.	
Slow Flash	Fast Flash	Heat Pump Inactive - Gas Mode Active	¹ Heat pump inactive mode due to outdoor temperature less than 32°F. ² Room thermostat temperature has called for second stage heat (gas furnace heat).	¹ Code will reset when outdoor temperature raises above 35°F for a calculated time period. ² Room thermostat demand is satisfied by furnace gas heat.

FAULT and LOCKOUT CODES (Each fault adds one strike to that code's counter; five strikes per code per room thermostat demand = LOCKOUT)

OFF	Slow Flash	Low Pressure Fault	¹ Restricted air flow over indoor or outdoor coil.	¹ Remove any blockages or restrictions from coils and/or fans. Check indoor and outdoor fan motor for proper current draws.
OFF	ON	Low Pressure Lockout	² Improper refrigerant charge in system.	² Check system charge using approach and subcooling temperatures.
Slow Flash	OFF	High Pressure Fault	³ Improper metering device installed or incorrect operation of metering device.	³ Check system operating pressures and compare to unit charging charts.
ON	OFF	High Pressure Lockout	⁴ Incorrect or improper sensor location or connection to system.	⁴ Make sure all pressure switches and sensors have secure connections to system to prevent refrigerant leaks or errors in pressure and temperature measurements.

NOTES —

- For proper operation the Demand Defrost Control must have 24VAC between **R** (system power input) and **C** (system common).
- Placing a jumper on the Demand Defrost Control's TEST pins will not activate the heat pump out of inactive mode. (24VAC power must be cycled to the Demand Defrost Control to activate the heat pump out of inactive mode) .
- If the Demand Defrost Control enters a low pressure LOCKOUT during heating mode, the outdoor unit will enter the heat pump inactive mode. The Demand Defrost Control will flash the low pressure code. If the room thermostat calls for Y1 heating in low pressure LOCKOUT, the Demand Defrost Control will alternately display two codes — four (4) seconds for the low pressure LOCKOUT, and then four (4) seconds heat pump inactive - gas mode active code.

5. DEFROST SYSTEM SENSORS

Sensors connect to the Demand Defrost Control through a field-replaceable harness assembly that plugs into the Demand Defrost Control. Through the sensors, the Demand Defrost Control detects outdoor ambient and coil temperature fault conditions. As the detected temperature change, the resistance across the sensors changes.

Table 11. Sensor Temperature / Resistance Range

Sensor	Temperature Range °F (°C)	Resistance values range (ohms)	Pins/Wire Color
Outdoor (Ambient)	-35 (-37) to 120 (48)	280,000 to 3750	3 and 4 (Black)
Coil	-35 (-37) to 120 (48)	280,000 to 3750	5 and 6 (Brown)

NOTE — Sensor resistance decreases as sensed temperature increases (see figure 12).

When a sensor indicates a resistance value that is not within the range as listed in table 11, then the following condition may be present:

- Sensor detects an out-of-range outdoor ambient air temperature condition and is displaying a light-emitting diode diagnostic code on the Demand Defrost Control.
- The sensor is operating normally. The ambient air temperature at the sensor is below or above the Demand Defrost Control's expected ohm values. The Demand Defrost Control will indicate the sensor as faulty. However the sensor has not failed.

Defrost Coil Sensor (RT21) — This sensor (shown in figure 1, detail A) considers outdoor temperatures below -35°F (-37°C) or above 120°F (48°C) to be a fault. If the defrost coil sensor is open, shorted or out of the temperature range of the sensor, the Demand Defrost Control will not perform demand or time/temperature defrost operation and will display the appropriate fault code. Heating and cooling operation will be allowed in this fault condition.

Ambient Sensor (RT13) — The ambient sensor (shown in figure 1, detail B) considers outdoor temperatures below -35°F (-37°C) or above 120°F (48°C) to be a fault. If the ambient sensor is shorted or out of the temperature range of the sensor, the Demand Defrost Control will not perform demand defrost operation. The Demand Defrost Control will revert to time/temperature defrost operation and will display the appropriate fault code. Heating and cooling operation will be allowed in this fault condition.

NOTE — If 5-strikes occur within a single room thermostat demand, the Demand Defrost Control will lock out the unit. Demand Defrost Control 24VAC power R must be cycled OFF, or place a jumper on TEST pins between 1 to 2 seconds to reset the Demand Defrost Control.

6. DEFROST MODE TERMINATION 27

Power Defrosts — Once a power defrost mode has been initiated, the following will occur:

- Will terminate and reset the internal timer if the coil sensor temperature exceeds the selected *Defrost Termination Temperature Setting*. If the *Defrost Termination Temperature Setting (P1)* jumper is not installed, the default termination temperature is 90°F.
- An internal timer shall count the time that the defrost mode is engaged and compressor is energized. After 14 minutes of operation in the defrost mode, the defrost sequence will terminate immediately and reset internal timer regardless of the state of the coil sensor temperature.

EXCEPTIONS — *High pressure switch open or locked out or anti-short cycle delay is active.*

Natural Defrosts — Natural defrosts should terminate after a fixed duration of 150 seconds.

7. TERMINOLOGY

The following is terminology that is used throughout the remainder of this instruction.

Power Defrost — A defrost cycle during which the compressor operates to melt any accumulated frost from the outdoor coil. A power defrost is needed in order to calibrate the Demand Defrost Control. During power defrost, the following occurs:

- Reversing valve is energized (as in a cooling mode)
- Compressor is energized.
- Outdoor fan is de-energized
- Indoor blower is de-energized

Natural Defrost — A defrost cycle where the compressor does not operate. Because the outdoor ambient is above freezing, just allowing the unit to sit idle will melt any frost from the outdoor coil. During natural defrost, the following occurs:

- Reversing valve is energized (as in a cooling mode)
- Compressor is de-energized
- Outdoor fan is de-energized
- Indoor blower is de-energized

Gas Heat Inactive Mode — When the outdoor temperature is above 65°F, the gas heat is not allowed to respond to a first-stage room thermostat heat call (Y1). The furnace is allowed to respond to a second-stage thermostat heat call (W1).

Heat Pump Inactive Mode — When the outdoor temperature is below 32°F, the heat pump is not allowed to respond to a first-stage room thermostat heat call (Y1). The Demand Defrost Control redirects this Y1 heat call to the furnace.

Table 12. Ambient (RT13) and Coil (RT21) Sensors Temperature / Resistance Range

Degrees Fahrenheit	Resistance	Degrees Fahrenheit	Resistance	Degrees Fahrenheit	Resistance	Degrees Fahrenheit	Resistance
136.3	2680	56.8	16657	21.6	44154	-11.3	123152
133.1	2859	56.0	16973	21.0	44851	-11.9	125787
130.1	3040	55.3	17293	20.5	45560	-12.6	128508
127.3	3223	54.6	17616	20.0	46281	-13.2	131320
124.7	3407	53.9	17942	19.4	47014	-13.9	134227
122.1	3592	53.2	18273	18.9	47759	-14.5	137234
119.7	3779	52.5	18607	18.4	48517	-15.2	140347
117.5	3968	51.9	18945	17.8	49289	-15.9	143571
115.3	4159	51.2	19287	17.3	50074	-16.5	146913
113.2	4351	50.5	19633	16.8	50873	-17.2	150378
111.2	4544	49.9	19982	16.3	51686	-17.9	153974
109.3	4740	49.2	20336	15.7	52514	-18.6	157708
107.4	4937	48.5	20695	15.2	53356	-19.3	161588
105.6	5136	47.9	21057	14.7	54215	-20.1	165624
103.9	5336	47.3	21424	14.1	55089	-20.8	169824
102.3	5539	46.6	21795	13.6	55979	-21.5	174200
100.6	5743	46.0	22171	13.1	56887	-22.3	178762
99.1	5949	45.4	22551	12.5	57811	-23.0	183522
97.6	6157	44.7	22936	12.0	58754	-23.8	188493
96.1	6367	44.1	23326	11.5	59715	-24.6	193691
94.7	6578	43.5	23720	11.0	60694	-25.4	199130
93.3	6792	42.9	24120	10.4	61693	-26.2	204829
92.0	7007	42.3	24525	9.9	62712	-27.0	210805
90.6	7225	41.7	24934	9.3	63752	-27.8	217080
89.4	7444	41.1	25349	8.8	64812	-28.7	223677
88.1	7666	40.5	25769	8.3	65895	-29.5	230621
86.9	7890	39.9	26195	7.7	67000	-30.4	237941
85.7	8115	39.3	26626	7.2	68128	-31.3	245667
84.5	8343	38.7	27063	6.7	69281	-32.2	253834
83.4	8573	38.1	27505	6.1	70458	-33.2	262482
82.3	8806	37.5	27954	5.6	71661	-34.1	271655
81.2	9040	37.0	28408	5.0	72890	-35.1	281400
80.1	9277	36.4	28868	4.5	74147	-36.1	291774
79.0	9516	35.8	29335	3.9	75431	-37.1	302840
78.0	9757	35.2	29808	3.4	76745	-38.2	314669
77.0	10001	34.7	30288	2.8	78090	-39.2	327343
76.0	10247	34.1	30774	2.3	79465		
75.0	10496	33.5	31267	1.7	80873		
74.1	10747	33.0	31766	1.2	82314		
73.1	11000	32.4	32273	0.6	83790		
72.2	11256	31.9	32787	0.0	85302		
71.3	11515	31.3	33309	-0.5	86852		
70.4	11776	30.7	33837	-1.1	88440		
69.5	12040	30.2	34374	-1.7	90068		
68.6	12306	29.6	34918	-2.2	91738		
67.7	12575	29.1	35471	-2.8	93452		
66.9	12847	28.6	36031	-3.4	95211		
66.0	13122	28.0	36600	-4.0	97016		
65.2	13400	27.5	37177	-4.6	98870		
64.4	13681	26.9	37764	-5.2	100775		
63.6	13964	26.4	38359	-5.7	102733		
62.8	14251	25.8	38963	-6.3	104746		
62.0	14540	25.3	39577	-6.9	106817		
61.2	14833	24.8	40200	-7.5	108948		
60.5	15129	24.2	40833	-8.2	111141		
59.7	15428	23.7	41476	-8.8	113400		
59.0	15730	23.2	42130	-9.4	115727		
58.2	16036	22.6	42794	-10.0	118126		
57.5	16345	22.1	43468	-10.6	120600		

8. HEAT PUMP INACTIVE MODE

Demand defrost control will enter heat pump inactive mode when any of the following conditions occurs:

- Outdoor temperature is less than 32°F (0°C).
- First Heat Pump Heating Call (after Demand Defrost Control Calibration) — Compressor run time in Heat Pump heating mode was less than 30 minutes before Demand Defrost Control requested a natural defrost.
- Second Heat Pump Call — Compressor run time in Heat Pump heating mode was less than 70% of the first heating call before Demand Defrost Control requested a natural defrost.
- Third Heat Pump Call — Heat Pump will become inactive at next call for natural defrost.

9. RETURN FROM HEAT PUMP INACTIVE MODE

When Demand Defrost Control determines outdoor temperature has been above 35°F (1.6°C) for calculated predetermined time, upon the next heat pump heating demand from the room thermostat, the Demand Defrost Control will immediately begin a sacrificial power defrost cycle as per figure 25.

NOTE — Placing a jumper on the Demand Defrost Control's TEST pins will not activate the heat pump out of inactive mode. Power (24VAC) must be cycled to the Demand Defrost Control to activate the heat pump out of inactive mode.

10. CALIBRATION MODE

The Demand Defrost Control is considered uncalibrated when:

- 24VAC power is applied to Demand Defrost Control during initial start up, or any other time that power is reapplied to the Demand Defrost Control.
- After being in cooling mode

The Demand Defrost Control will perform a sacrificial power defrost after thirty (30) minutes of accumulated

compressor runtime in the first heat pump heating demand with the coil temperature below 35°F (2°C). This will ensure a clear outdoor coil before an attempts to calibrate the Demand Defrost Control.

- When the heat pump comes out of inactive mode. The Demand Defrost Control will perform a sacrificial power defrost. This will ensure a clear outdoor coil before an attempts to calibrate the Demand Defrost Control

NOTE — If the heat pump is running in a gas furnace heating demand when the heat pump comes out of inactive mode, the Demand Defrost Control will cycle the gas furnace OFF and cycle the heat pump ON. On this first call for heat pump heating the Demand Defrost Control will initial a sacrificial defrost to ensure a clear outdoor coil before an attempts to calibrate the Demand Defrost Control.

Calibration of the Demand Defrost Control occurs after a power defrost cycle to ensure that there is no ice on the coil. During calibration, the temperature of both the coil and ambient sensors are measured to establish a clear coil condition.

When the controller is in an uncalibrated state, the controller should initiate a sacrificial defrost after 30 minutes of accumulated compressor runtime with coil temperature below 35°F. The defrost cycle will terminate if the coil sensor reaches the selected termination temperature or after a 14-minute defrost. If the above defrost was concluded due to termination temperature, or if terminated by time with a coil temperature of greater than 35°F for more than a defined time, a clear coil (non-iced condition) can be assumed. Otherwise, the Demand Defrost Control remains in an uncalibrated state.

If the coil temperature is not considered stable, the Demand Defrost Control will operate in time-temperature mode for 45 minutes. Upon the completion of the 45-minute operation the Demand Defrost Control will initiate a sacrificial defrost to calibrate. At that point a clear coil temperature at the particular outdoor ambient temperature can be determined.

TEST

Placing the jumper on the test pins allows the technician to:

- Clear short cycle lockout
- Clear five-strike fault lockout
- Cycle the unit in and out of defrost mode
- Place the unit in defrost mode to clear the coil

When Y1 is energized and 24V power is being applied to the Demand Defrost Control, a test cycle can be initiated by placing a jumper on the Demand Defrost Control's TEST pins for 2 to 5 seconds. If the jumper remains on the TEST pins for longer than five seconds, the Demand Defrost Control will ignore the jumpered TEST pins and revert to normal operation.

The control will initiate one test event each time a jumper is placed on the TEST pins. For each TEST the jumper must be removed for at least one second and then reapplied.

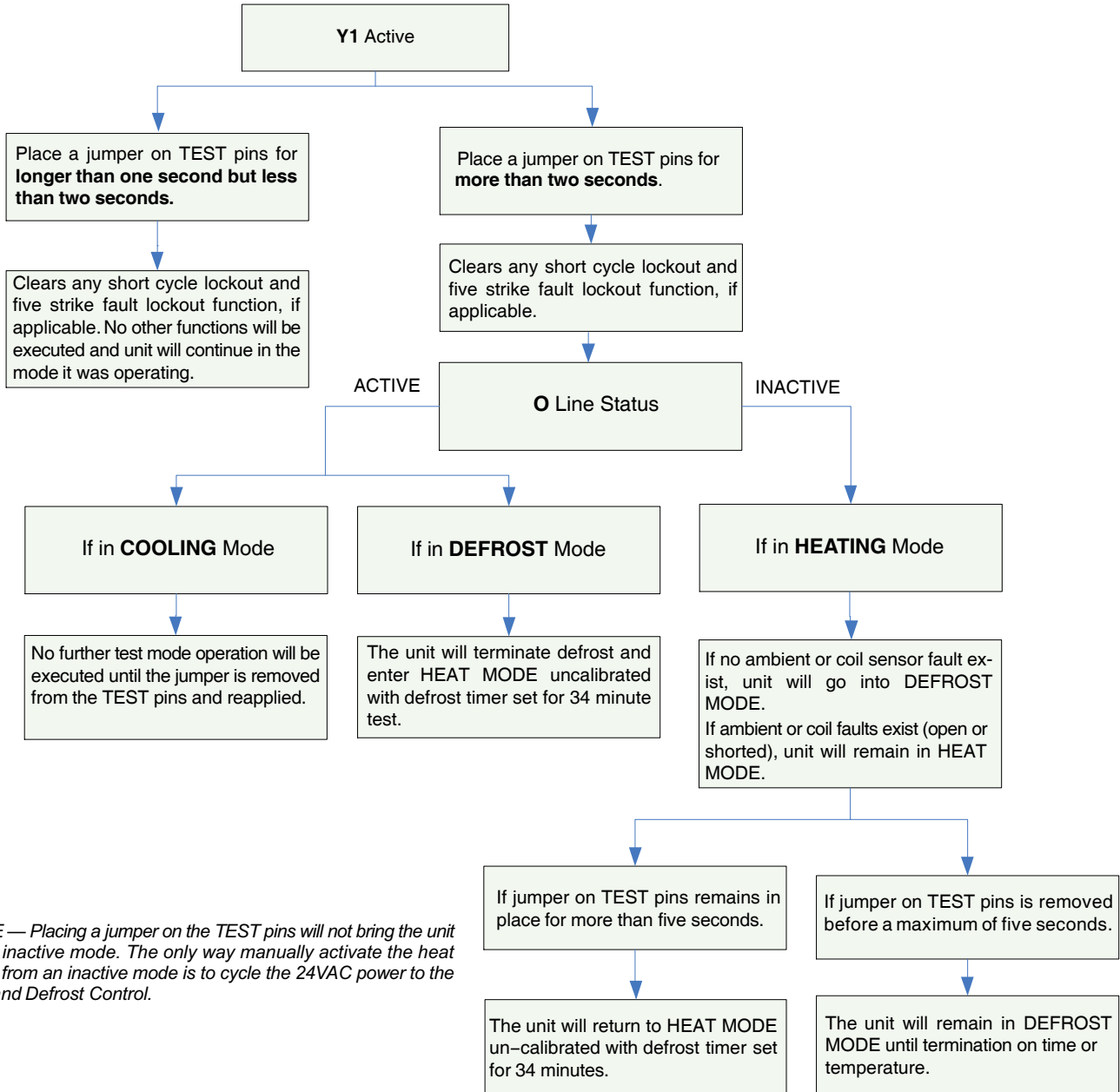
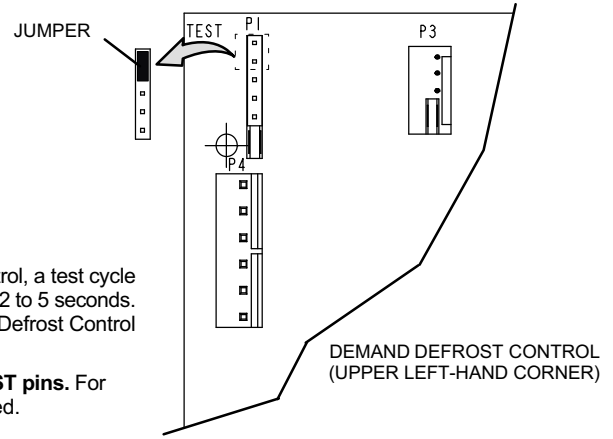

NOTE — Placing a jumper on the TEST pins will not bring the unit out of inactive mode. The only way manually activate the heat pump from an inactive mode is to cycle the 24VAC power to the Demand Defrost Control.

Figure 24. Test Mode

The Demand Defrost Control is considered uncalibrated when:

- 24VAC power is applied to Demand Defrost Control during initial start up, or any other time that power is reapplied to the Demand Defrost Control.
- After being in cooling mode

The Demand Defrost Control will perform a sacrificial power defrost after thirty (30) minutes of accumulated compressor runtime in the first heat pump heating demand with the coil temperature below 35°F (1.6°C). This will ensure a clear outdoor coil before an attempt to calibrate the Demand Defrost Control.

- When the heat pump comes out of inactive mode.

The Demand Defrost Control will perform a sacrificial power defrost. This will ensure a clear outdoor coil before an attempt to calibrate the Demand Defrost Control.

NOTE — If the heat pump is running in a gas furnace heating demand when the heat pump comes out of inactive mode, the Demand Defrost Control will cycle the gas furnace OFF and cycle the heat pump ON. On this first call for heat pump heating the Demand Defrost Control will initiate a sacrificial defrost to ensure a clear outdoor coil before an attempt to calibrate the Demand Defrost Control.

SEQUENCE OF OPERATION IS CLOCKWISE

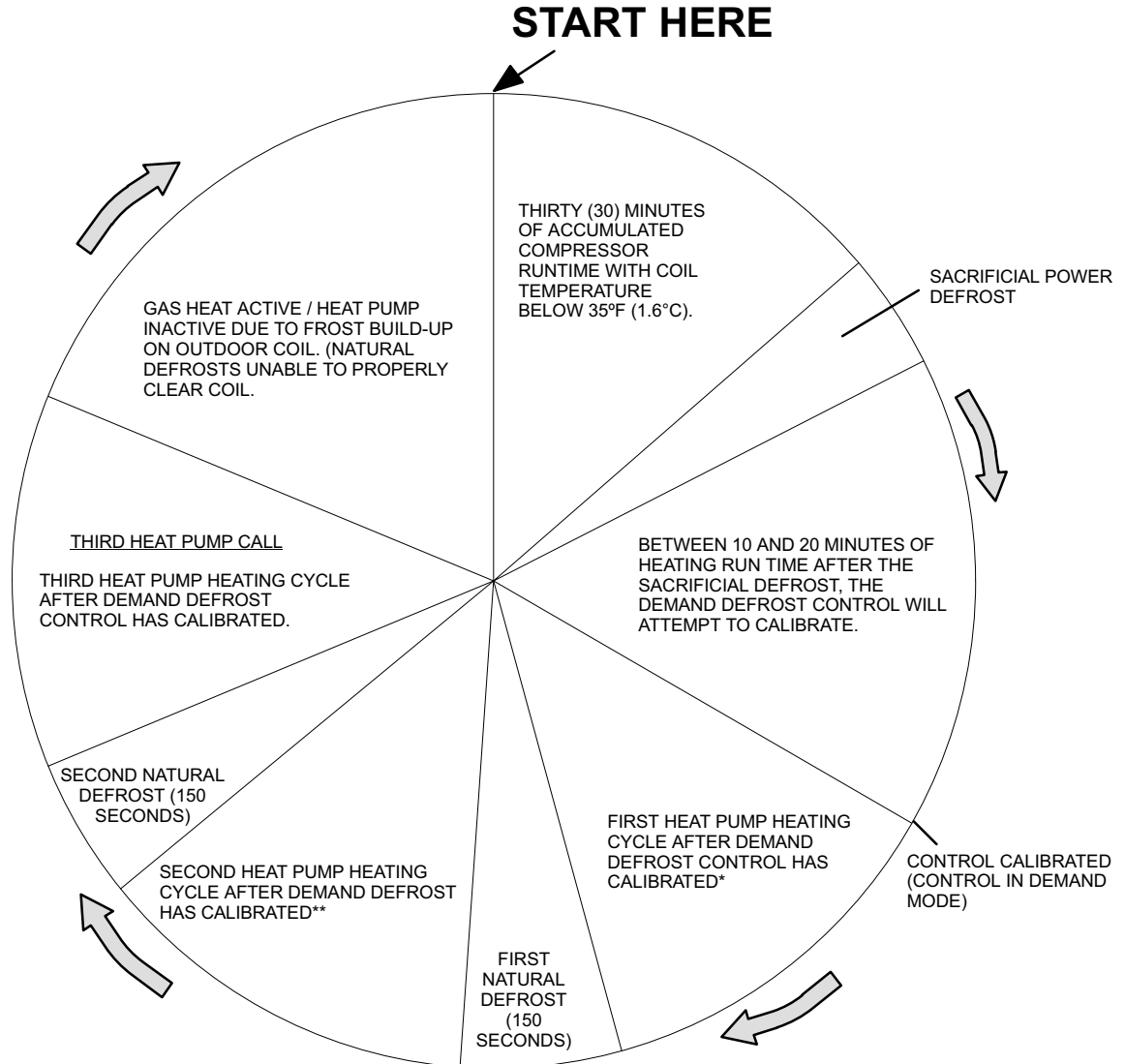

** SECOND HEAT PUMP CALL — COMPRESSOR RUN TIME IN HEAT PUMP HEATING MODE WAS:

LESS THAN 70% OF THE FIRST HEATING CALL BEFORE DEMAND DEFROST CONTROL REQUESTED A NATURAL DEFROST — HEAT PUMP GOES INACTIVE / GAS HEAT ACTIVE.

MORE THAN 70% OF THE FIRST HEATING CALL BEFORE DEMAND DEFROST CONTROL REQUESTED A NATURAL DEFROST — HEAT PUMP GOES INTO NATURAL DEFROST MODE

* FIRST HEAT PUMP CALL — COMPRESSOR RUN TIME IN HEAT PUMP HEATING MODE WAS:

LESS THAN 30 MINUTES BEFORE DEMAND DEFROST CONTROL REQUESTED A NATURAL DEFROST — HEAT PUMP GOES INACTIVE / GAS HEAT ACTIVE.

MORE THAN 30 MINUTES BEFORE DEMAND DEFROST CONTROL REQUESTED A NATURAL DEFROST — HEAT PUMP GOES INTO NATURAL DEFROST MODE.

Figure 25. Dual-Fuel Defrost Cycles

Operating Modes²⁸

COOLING OPERATING MODE

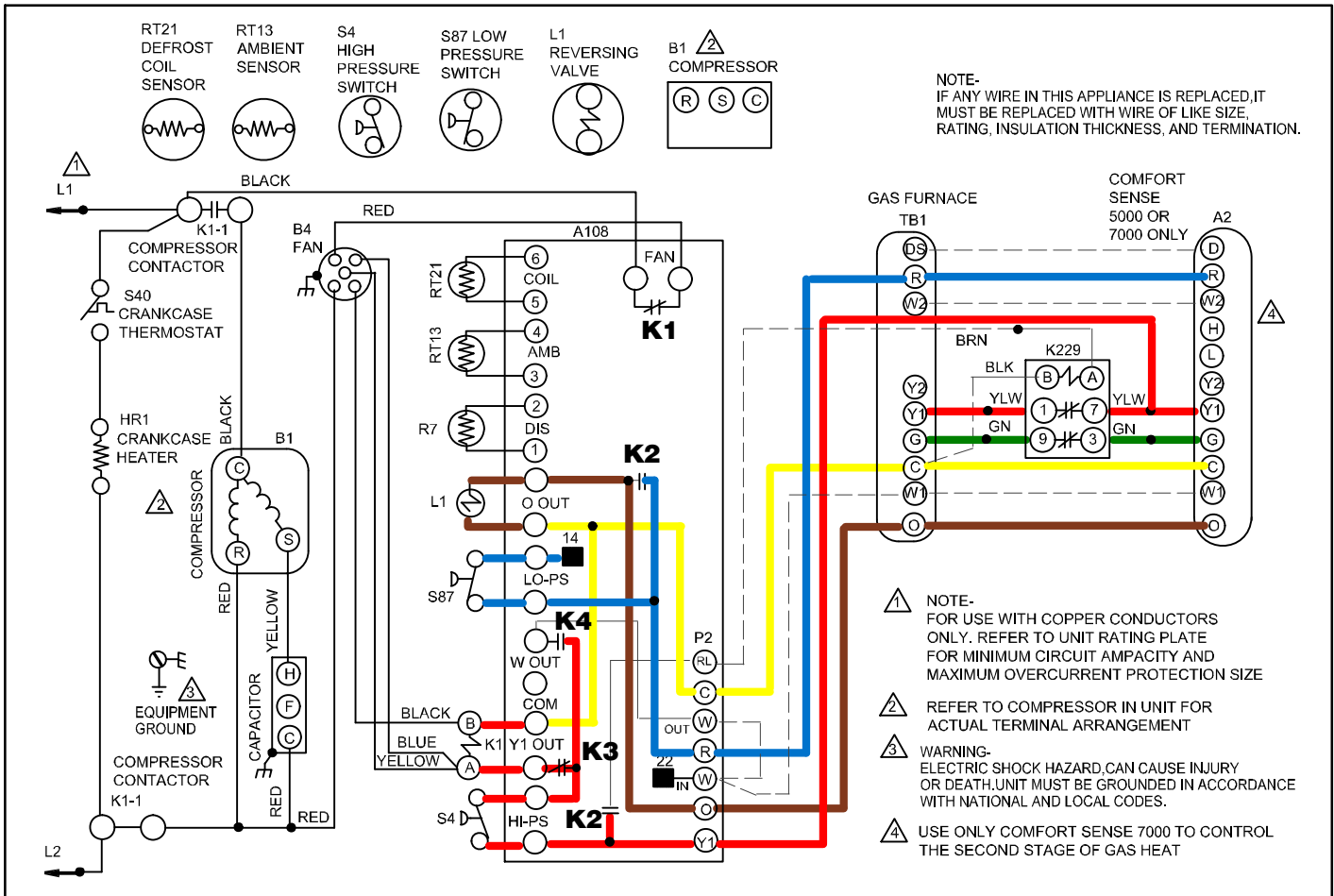

Operation Mode	ComfortSense®							Gas Furnace					Dedicated Heat Pump (XPG15)						
INPUTS/OUTPUTS ▶	Y1	W1	W2	O	G	E	L	Y1	Y2	W1	W2	G	O	Y1	W IN	RL/ K229	O	Y1 OUT	W OUT
Cooling Mode																			
OFF				X													X		
Cooling	X			X	X			X				X	X	X			X	X	

DEMAND DEFROST CONTROL INTERNAL RELAY CONTACT STATUS

1. K1 relay contact remain closed.
2. K2 relay contact (two sets) remain open.
3. Reversing valve is energized through room thermostat.
4. K3 relay contact close to energize compressor contactor.
5. K4 relay contact remain open.

EXCEPTIONS — Low or high pressure switch open or five (5) strike pressure switch lockout or anti-short delay (five minutes) active.

HEATING OPERATING MODE — ROOM THERMOSTAT DEMAND FOR Y1 WITH OUTDOOR TEMPERATURE ABOVE 32°F (0°C)

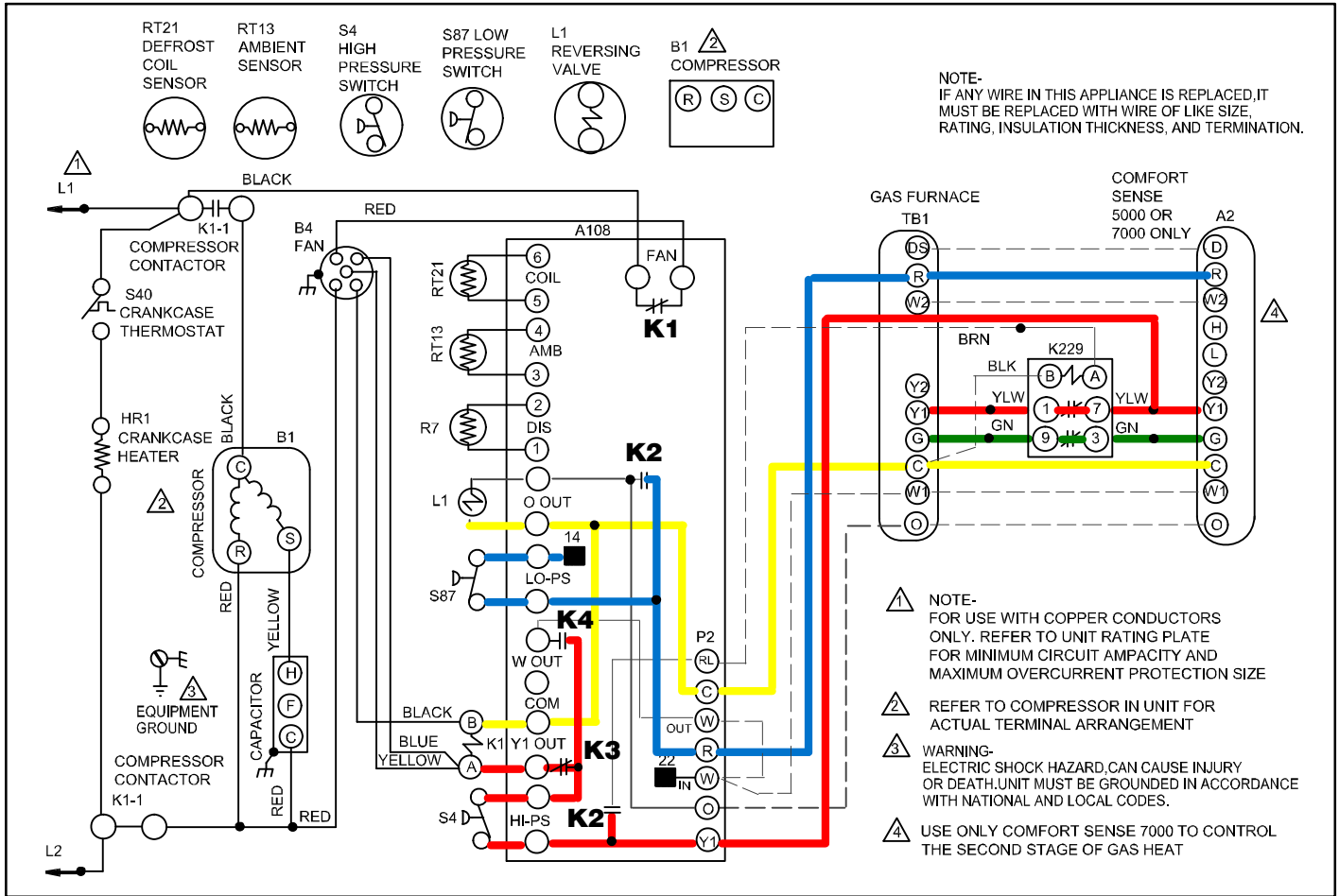

Operation Mode	ComfortSense®							Gas Furnace					Dedicated Heat Pump (XPG15)						
INPUTS/OUTPUTS ▶	Y1	W1	W2	O	G	E	L	Y1	Y2	W1	W2	G	O	Y1	W IN	RL/ K229	O	Y1 OUT	W OUT
Heating Mode (Outside Temperature above 32°F)																			
First Stage Heating (Heat Pump)	X				X			X				X		X				X	

DEMAND DEFROST CONTROL INTERNAL RELAY CONTACT STATUS

1. K1 relay contact remain closed.
2. K2 relay contact (two sets) remain open.
3. K3 relay contact close to energize compressor contactor.
4. K4 relay contact remain open.
5. K229 relay normally closed contacts remain closed.

HEATING OPERATING MODE — ROOM THERMOSTAT DEMAND FOR Y1 AND W1 WITH OUTDOOR TEMPERATURE ABOVE 32°F (0°C)

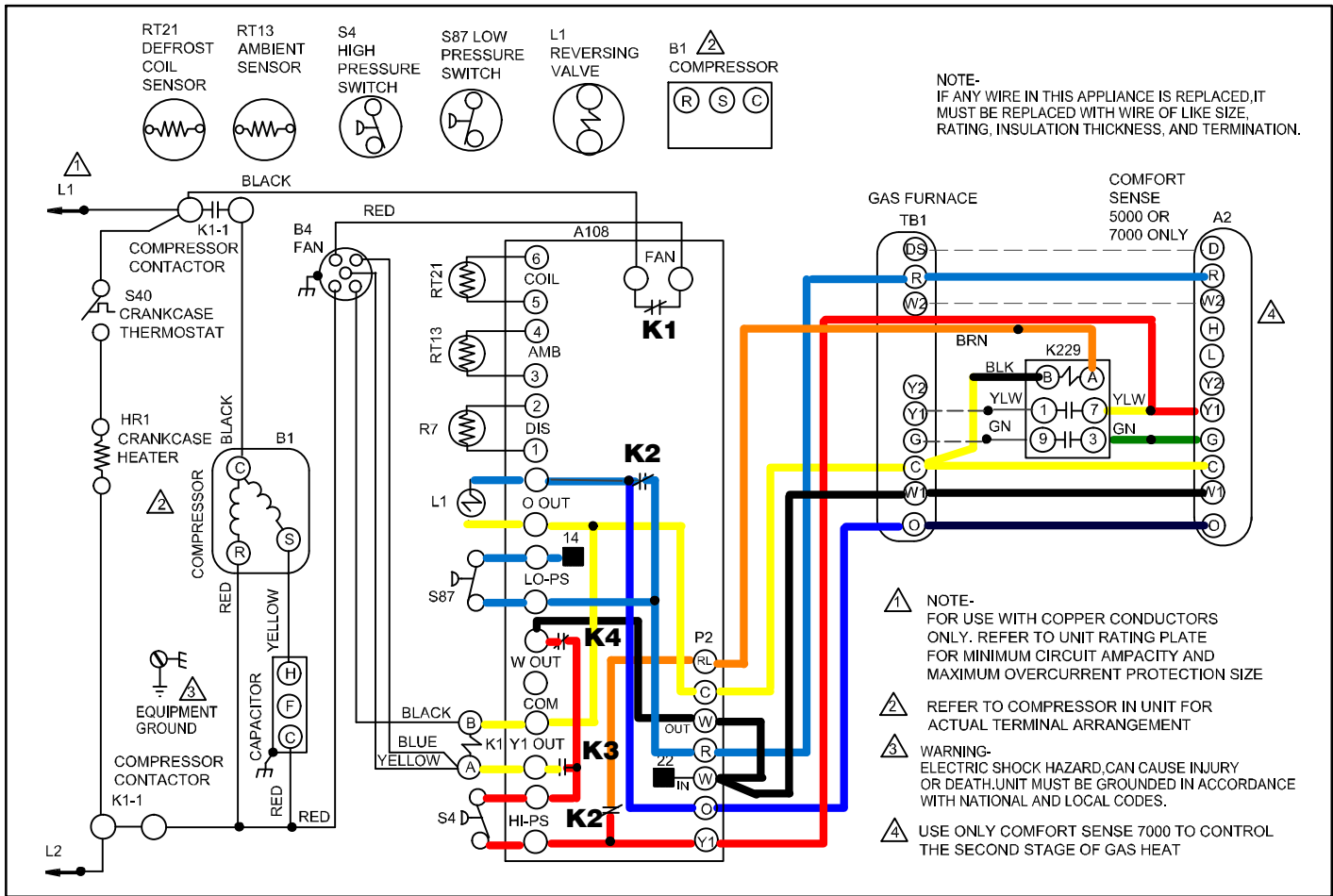

Operation Mode	ComfortSense®							Gas Furnace					Dedicated Heat Pump (XPG15)						
	Y1	W1	W2	O	G	E	L	Y1	Y2	W1	W2	G	O	Y1	W IN	RL/ K229	O	Y1 OUT	W OUT
Heating Mode (Outside Temperature above 32°F)																			
First Stage Heating (Heat Pump)	X				X			X				X		X				X	
Second Stage Heating (First Stage Gas Heat)	X	X			X					X			X	X	X	X	X		X
Third Stage Heating (Second Stage Gas Heat)	X	X	X		X					X	X		X	X	X	X	X		X

DEMAND DEFROST CONTROL INTERNAL RELAY CONTACT STATUS

1. K1 relay contact remain closed.
2. K2 relay contact (two sets) close and output 24VAC to RL output to energize K229 field installed relay.
3. K3 relay contact open and de-energize compressor contactor.
4. K4 relay contact remain closed.
5. K229 relay with normally closed contacts is now open and removes the Y1 and G signals going from the room thermostat to the furnace control. This allows the furnace to control the indoor blower operation during gas heat operations.

NOTE — When Demand Defrost Control receives Y1 and W in room thermostat demands, the gas furnace will satisfy both room thermostat demands before cycling OFF.

HEATING OPERATING MODE — ROOM THERMOSTAT DEMAND FOR Y1 WITH OUTDOOR TEMPERATURE BELOW 32°F (0°C)

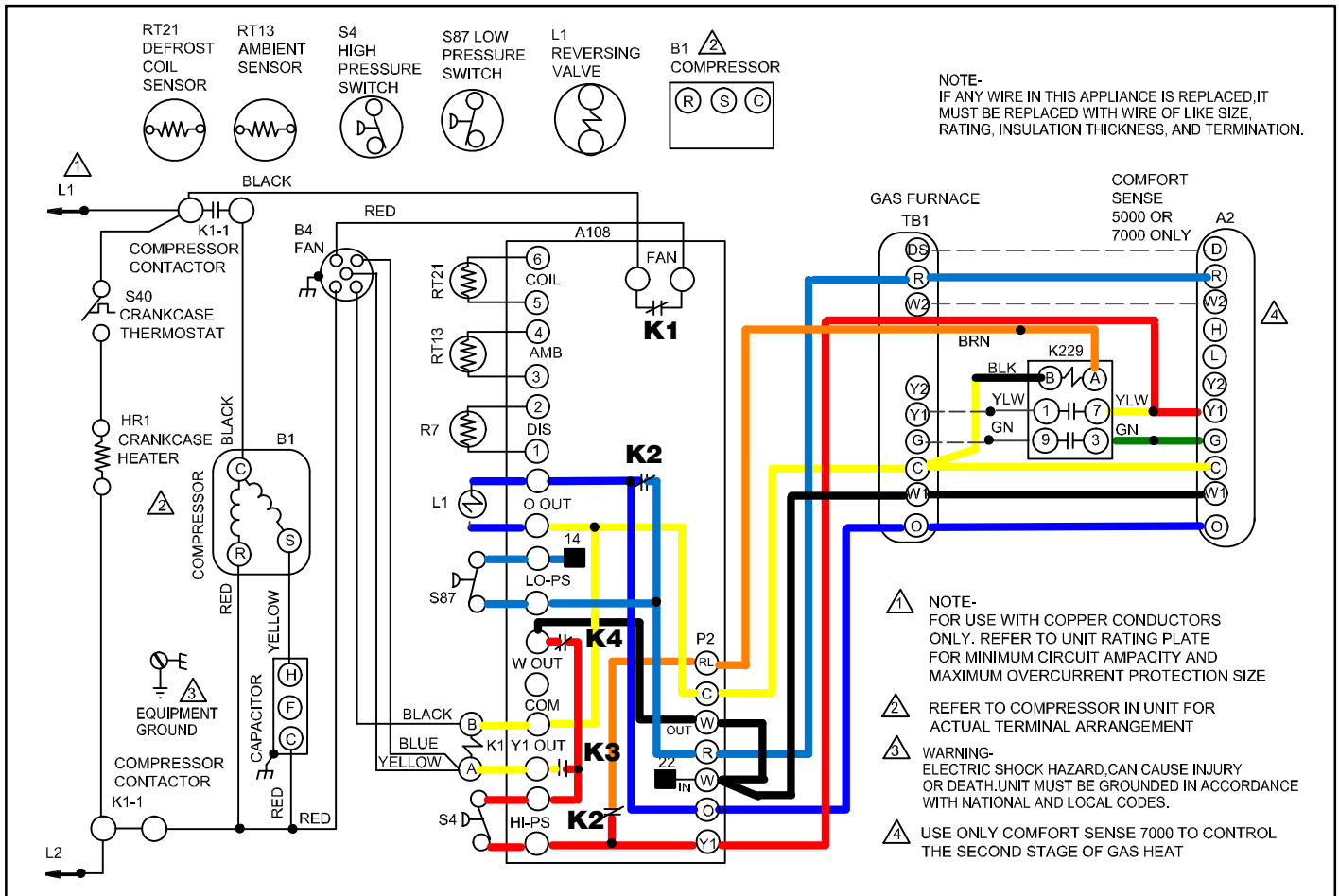

Operation Mode	ComfortSense®						Gas Furnace						Dedicated Heat Pump (XPG15)						
INPUTS/OUTPUTS ▶	Y1	W1	W2	O	G	E	L	Y1	Y2	W1	W2	G	O	Y1	W IN	RL/ K229	O	Y1 OUT	W OUT
Heating Mode (Outside Temperature above 32°F)																			
First Stage Heating (Heat Pump)	X				X					X			X	X	X	X	X		X

DEMAND DEFROST CONTROL INTERNAL RELAY CONTACT STATUS

1. K1 relay contact remain closed.
2. K2 relay contact close and output 24VAC to **RL** output to energize K229 field installed relay.
3. K2 relay contact close and energize reversing valve.
4. K3 relay contact open and de-energize compressor contactor due to outdoor temperature being below 32°F (0°C). Heat pump goes into inactive mode.
5. K4 relay contact close and send 24VAC to **W out** terminal. Gas furnace will satisfy **Y1** heat demands.
6. K229 relay with normally closed contacts is now open and removes the **Y1** and **G** signals going from the room thermostat to the furnace control. This allows the furnace to control the indoor blower operation during gas heat operation.

POWER DEFROST MODE

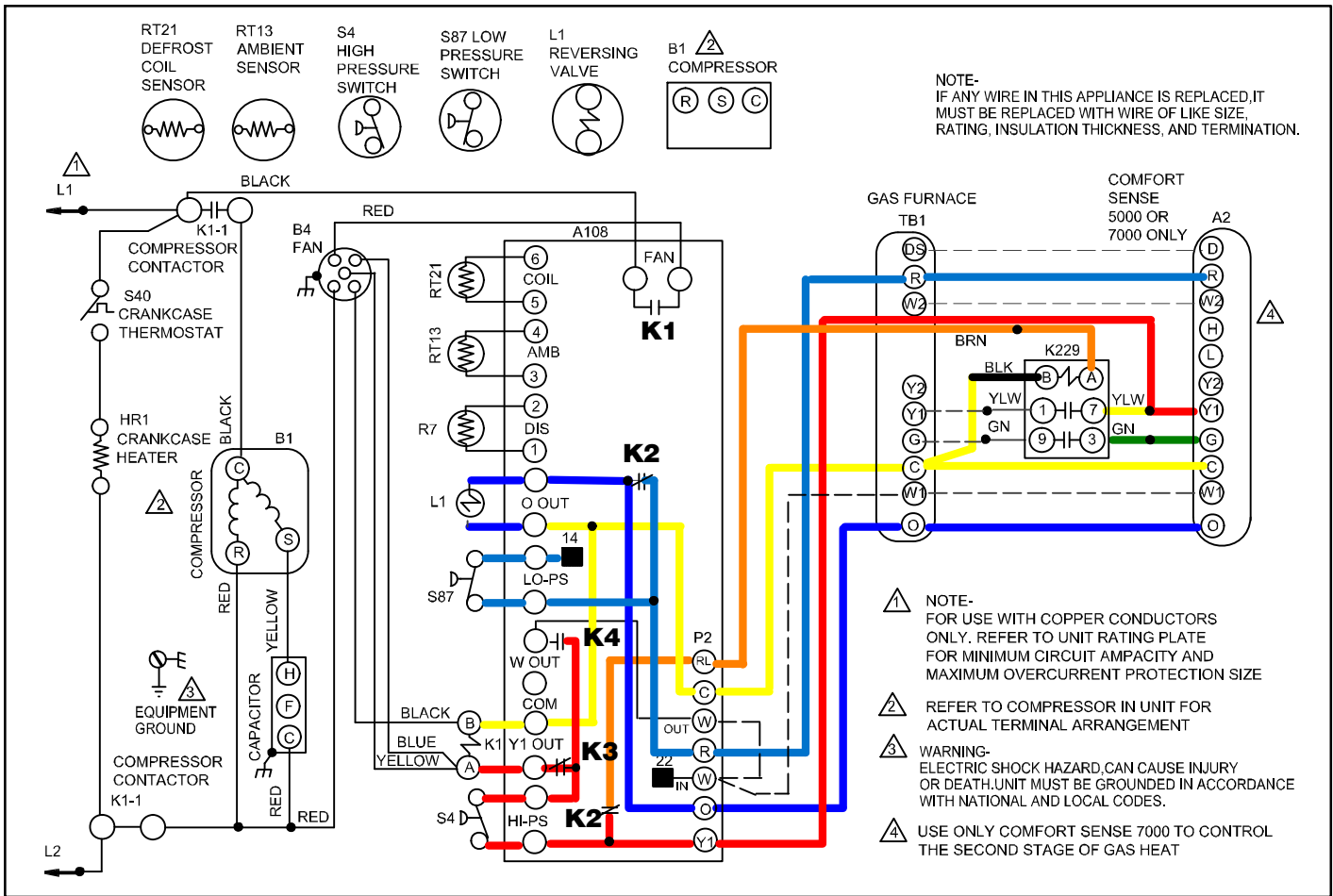

Operation Mode	ComfortSense®							Gas Furnace					Dedicated Heat Pump (XPG15)							
INPUTS/OUTPUTS ▶	Y1	W1	W2	O	G	E	L	Y1	Y2	W1	W2	G	O	Y1	W IN	RL/ K229	O	Y1 OUT	W OUT	
Defrost Mode																				
Power Defrost	X					X							X	X		X	X	X		

DEMAND DEFROST CONTROL INTERNAL RELAY CONTACT STATUS

1. K1 relay contact open to cycle OFF outdoor fan.
2. K2 relay contact close and output 24VAC to RL output to energize K229 field installed relay.
3. K2 relay contact close and energize reversing valve.
4. K3 relay contact close and energize compressor contactor.
5. K4 relay contact remain open.
6. K229 relay with normally closed contacts is now open and removes the Y1 and G signals going from the room thermostat to the furnace control. Indoor blower will cycle OFF.

DEFROST TERMINATION

Once a power defrost mode has been initiated, the next event will occur as explained on page 41.

NATURAL DEFROST MODE

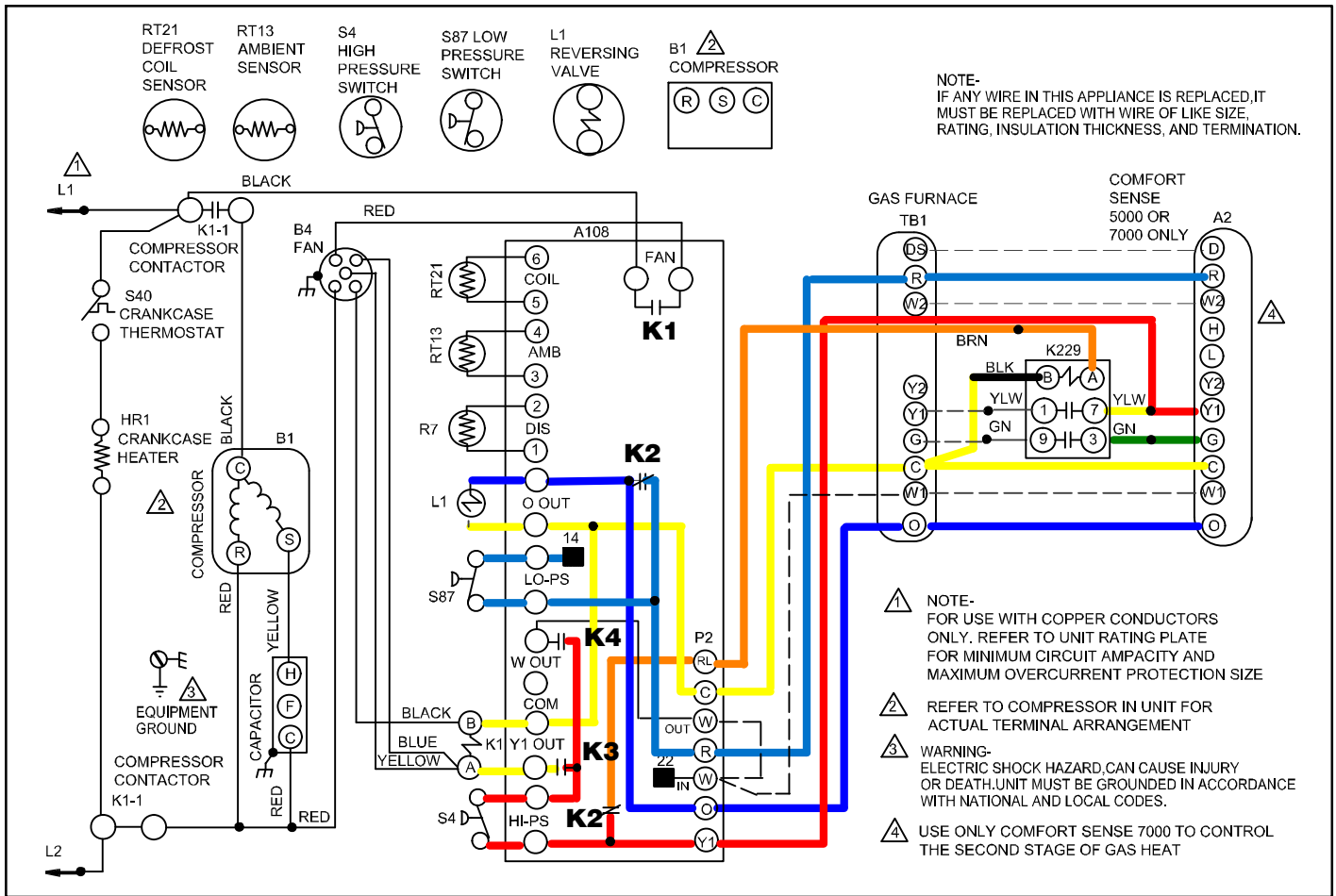

Operation Mode	ComfortSense®							Gas Furnace					Dedicated Heat Pump (XPG15)						
INPUTS/OUTPUTS ▶	Y1	W1	W2	O	G	E	L	Y1	Y2	W1	W2	G	O	Y1	W IN	RL/ K229	O	Y1 OUT	W OUT
Defrost Mode																			
Natural Defrost	X				X								X	X		X	X		

DEMAND DEFROST CONTROL INTERNAL RELAY CONTACT STATUS

1. K1 relay contact open to cycle OFF outdoor fan.
2. K2 relay contact close and output 24VAC to **RL** output to energize K229 field installed relay.
3. K2 relay contact close and energize reversing valve.
4. K3 relay contact open and de-energize compressor contactor.
5. K4 relay contact remain open.
6. K229 relay with normally closed contacts is now open and removes the **Y1** and **G** signals going from the room thermostat to the furnace control. Indoor blower will cycle OFF.

DEFROST TERMINATION

Natural defrosts should be terminated after a fixed duration of 150 seconds.

COOLING

Mode Operation

DEFROST CONTROL (ON-BOARD RELAYS)

- K1 – Outdoor Fan (Normally Closed)
- K2 – Reversing valve & RL output
- K3 – Compressor Y1 out
- K4 – W out
- ASCD – Anti-short Cycle Delay

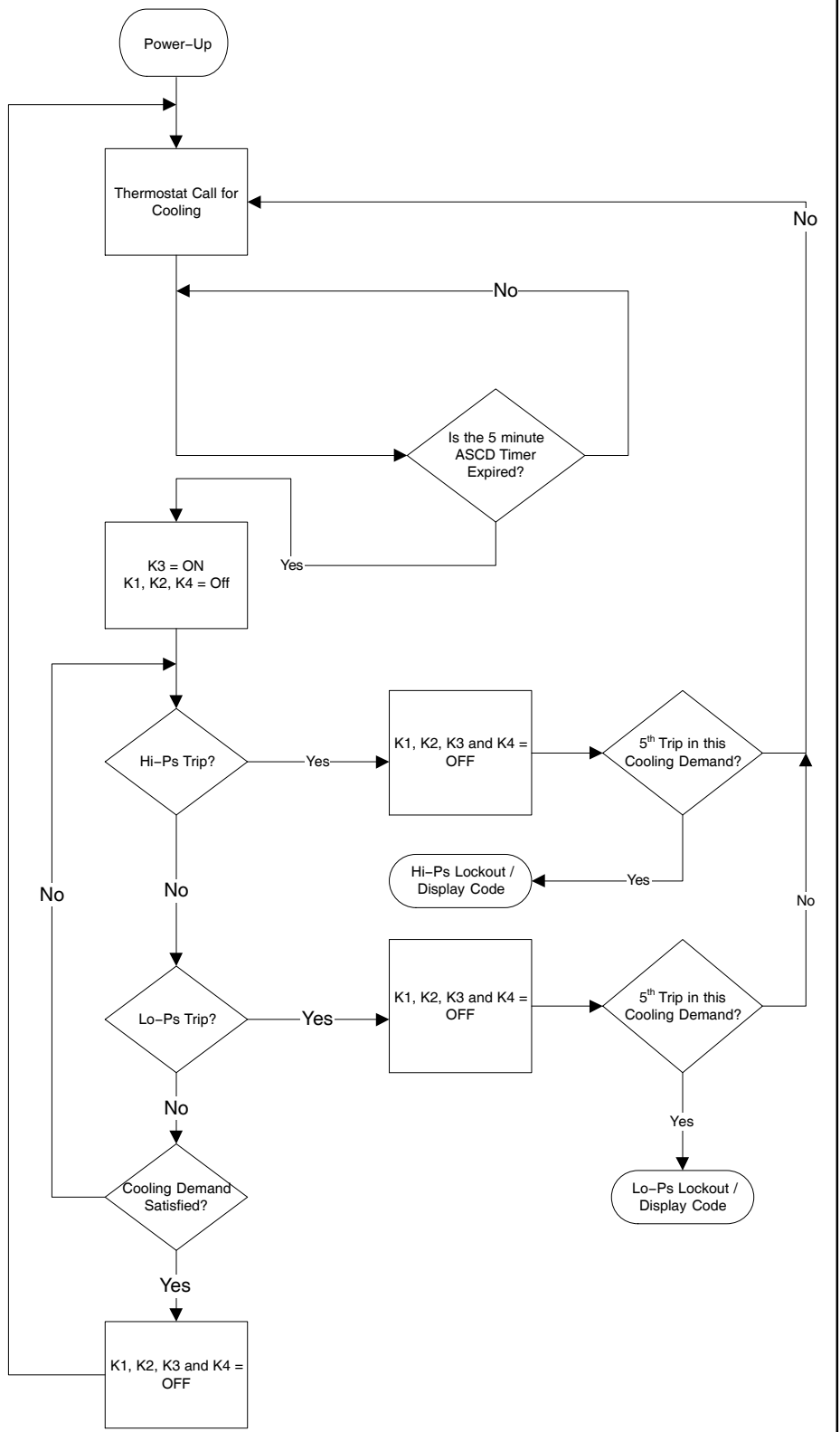

Figure 26. Cooling Mode Operation

HEATING

Mode (O — Input not Present)

DEFROST CONTROL (ON-BOARD RELAYS)

- K1 — Outdoor Fan (Normally Closed)
- K2 — Reversing valve & RL output
- K3 — Compressor Y1 out
- K4 — W out
- ASCD — Anti-short Cycle Delay

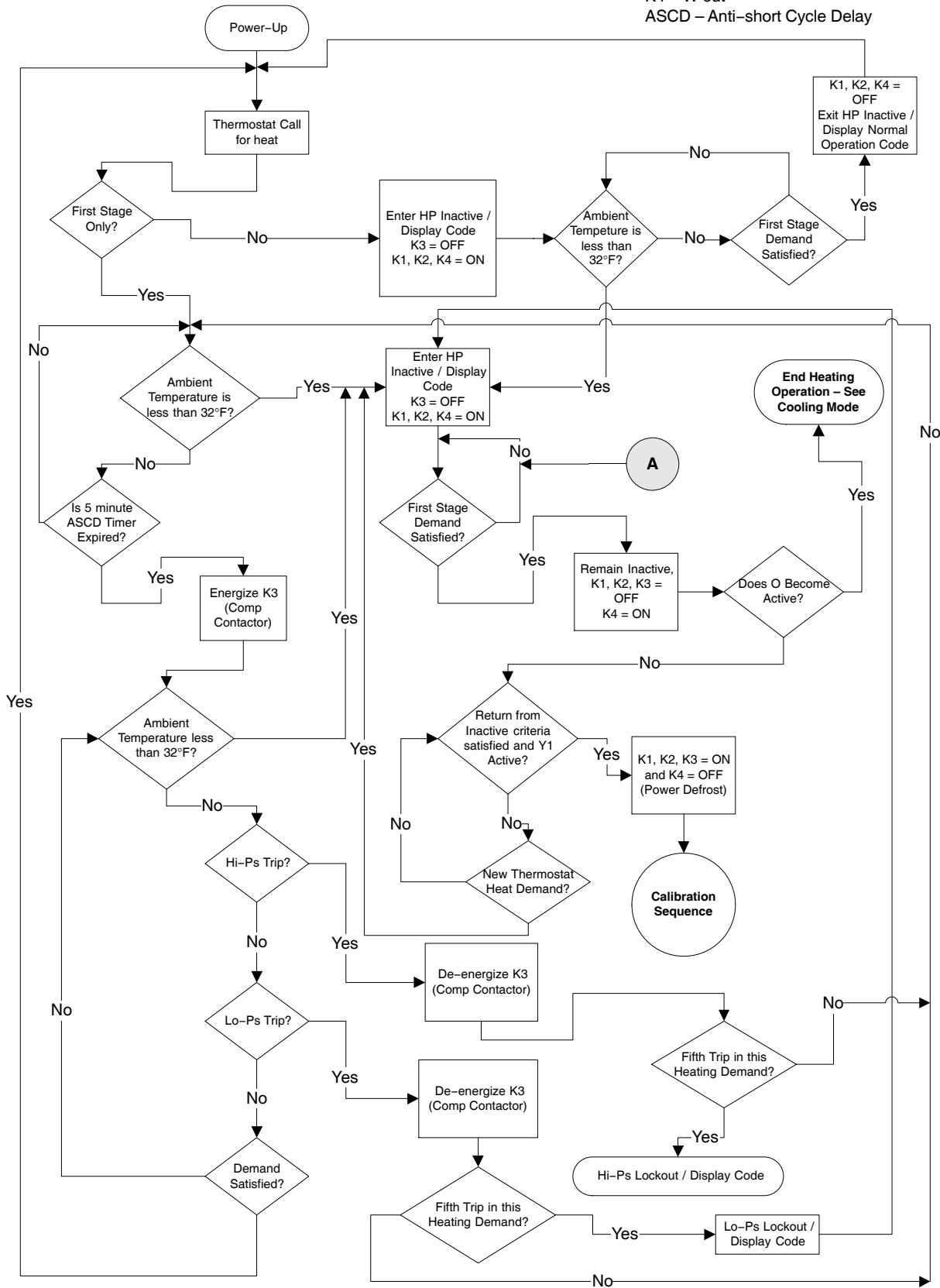

Figure 27. Heating Mode Operation

DEFROST CONTROL (ON-BOARD RELAYS)

- K1 – Outdoor Fan (Normally Closed)
- K2 – Reversing valve & RL output
- K3 – Compressor Y1 out
- K4 – W out
- ASCD – Anti-short Cycle Delay
- i - Number of natural defrosts

CALIBRATION

Sequence

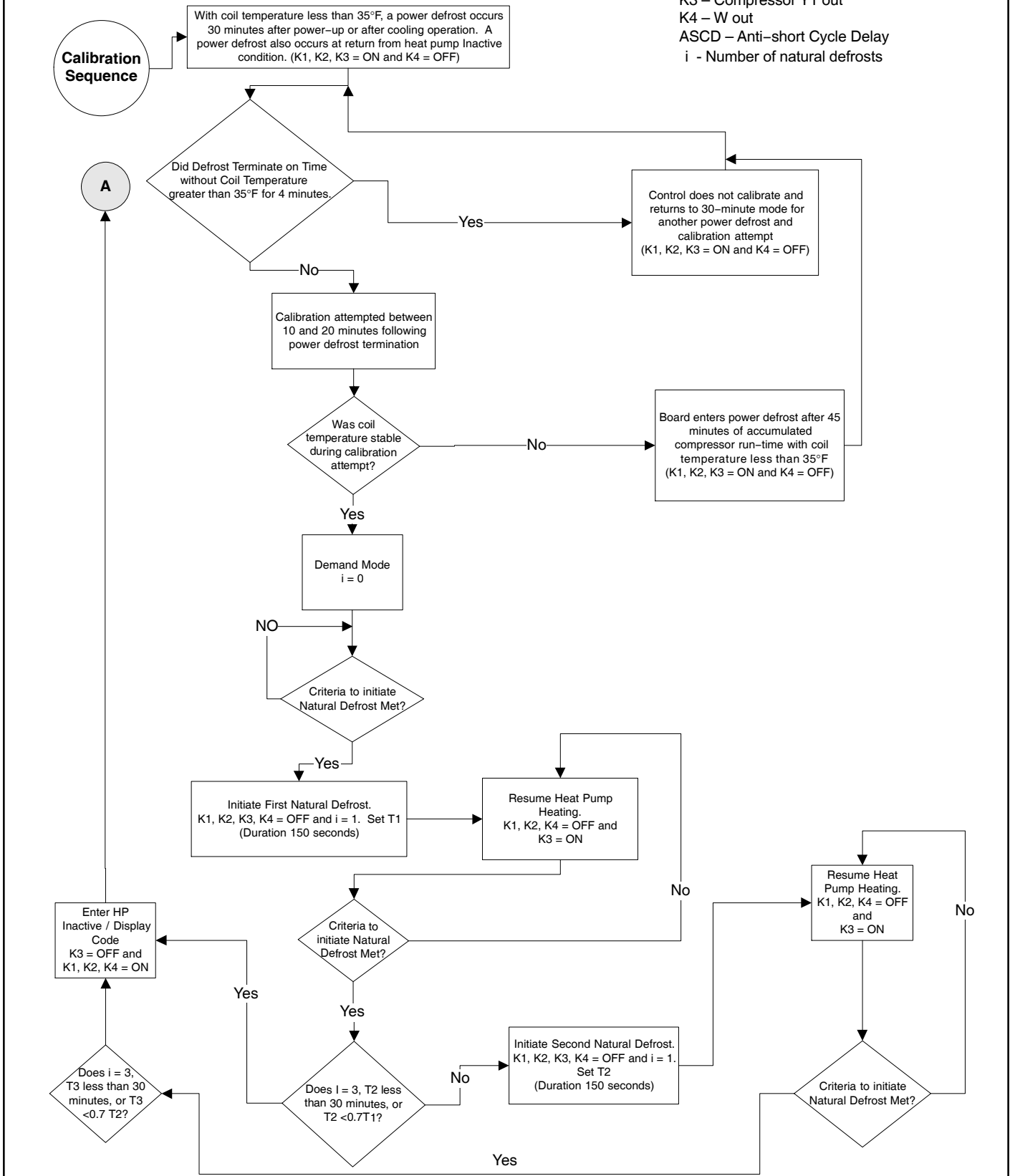

Figure 28. Calibration Sequence

⚠ WARNING



Electric shock hazard. Can cause injury or death. Before attempting to perform any service or maintenance, turn the electrical power to unit OFF at disconnect switch(es). Unit may have multiple power supplies.

Before the start of each heating and cooling season, the following service checks should be performed by a licensed professional service technician or equivalent. First, turn off electrical power to the unit prior to performing unit maintenance.

- Inspect and clean the outdoor and indoor coils. The outdoor coil may be flushed with a water hose.

NOTE — It may be necessary to flush the outdoor coil more frequently if it is exposed to substances which are corrosive or which block airflow across the coil (e.g., pet urine, cottonwood seeds, etc.)

- Visually inspect the refrigerant lines and coils for leaks.
- Check wiring for loose connections.
- Check voltage at the indoor and outdoor units (with units operating).
- Check the amperage draw at the outdoor fan motor, compressor, and indoor blower motor. Values should be compared with those given on unit nameplate.
- Check, clean (or replace) indoor unit filters.
- Check the refrigerant charge and gauge the system pressures.
- Check the condensate drain line for free and unobstructed flow; clean, if necessary.
- Outdoor unit fan motor is prelubricated and sealed. No further lubrication is needed.
- **Outdoor Coil** — The outdoor coil may be flushed with a water hose.
- **Outdoor Coil (Sea Coast)** — Moist air in ocean locations can carry salt, which is corrosive to most metal. Units that are located near the ocean will require frequent inspections and maintenance. These inspections will determine the necessary need to wash the unit including the outdoor coil.

When removing debris from around the unit, be aware of metal edges on parts and screws. Although special care has been taken to keep exposed edges to a minimum, physical contact with metal edges and corners while applying excessive force or rapid motion can result in personal injury.

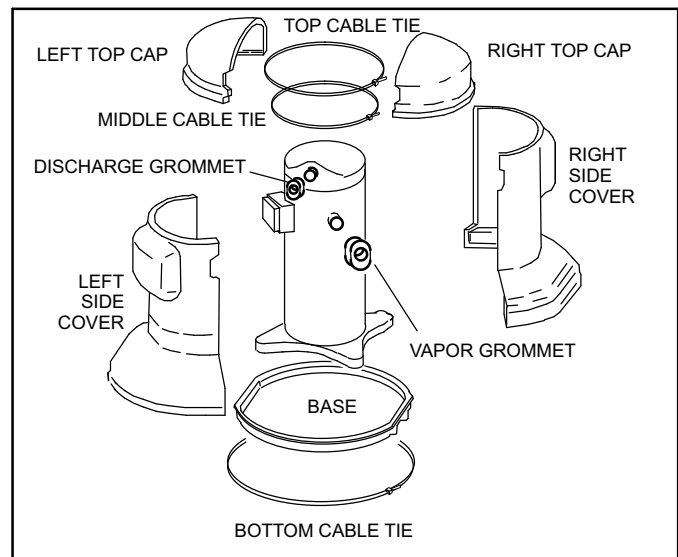

Figure 29. Sound Reduction Cover Parts

ASSEMBLY PROCEDURE

Figure 29 identifies the sound reduction parts. The assembly procedure is as follows:

1. Put SR1 base on unit base pan.
2. Install compressor on base.
3. Cover SR1 base with wet rags to protect against any brazing material.
4. Braze vapor tube.
5. Braze discharge tube.
6. Cool connections to ambient temperature.
7. Perform leak check.
8. Install vapor grommet.
9. Install SR1 left and right side covers.
10. Fasten 60" bottom cable tie.
11. Install discharge grommet.
12. Install top caps.
13. Fasten 36" top cable tie.
14. Fasten 36" middle cable tie.

To remove sound reduction cover, reverse order the above procedure.

15. Check running current. The readings should not exceed manufacturer's full load rated amps during heavy load periods. Low amps are normal during low load conditions. Excessive high current may be due to shorted or grounded windings, a bad capacitor, a faulty start relay, or an indication of excessive bearing fatigue.

Caution — When performing electrical measurements on compressors with internal thermal motor protection devices that have been running extremely hot, be sure to give the compressor time to cool down prior to the electrical test. This will allow the device to reset to its normal position.