

**SSB\*H4 Commercial Air Conditioner**

The SSB\*H4 is a high efficiency commercial split-system condensing unit, which features a two stage scroll compressor and R-410A refrigerant. SSB\*H4 units are available in 3, 4 and 5 ton capacities. The series is designed for use with an expansion valve (approved for use with R-410A) in the indoor unit. This manual is divided into sections which discuss the major components, refrigerant system, charging procedure, maintenance and operation sequence.



**⚠ WARNING**  
Improper installation, adjustment, alteration, service or maintenance can cause personal injury, loss of life, or damage to property.  
Installation and service must be performed by a licensed professional installer (or equivalent) or a service agency.

**⚠ CAUTION**  
Physical contact with metal edges and corners while applying excessive force or rapid motion can result in personal injury. Be aware of, and use caution when working near these areas during installation or while servicing this equipment.

**TABLE OF CONTENTS**

General ..... Page 1  
 Specifications / Electrical Data ..... Page 2  
 I Application ..... Page 4  
 II Unit Components ..... Page 4  
 III Refrigeration System ..... Page 12  
 IV Charging ..... Page 13  
 V Service and Recovery ..... Page 20  
 VI Maintenance ..... Page 21  
 VII Wiring and Sequence of Operation .. Page 22

**MODEL NUMBER IDENTIFICATION**

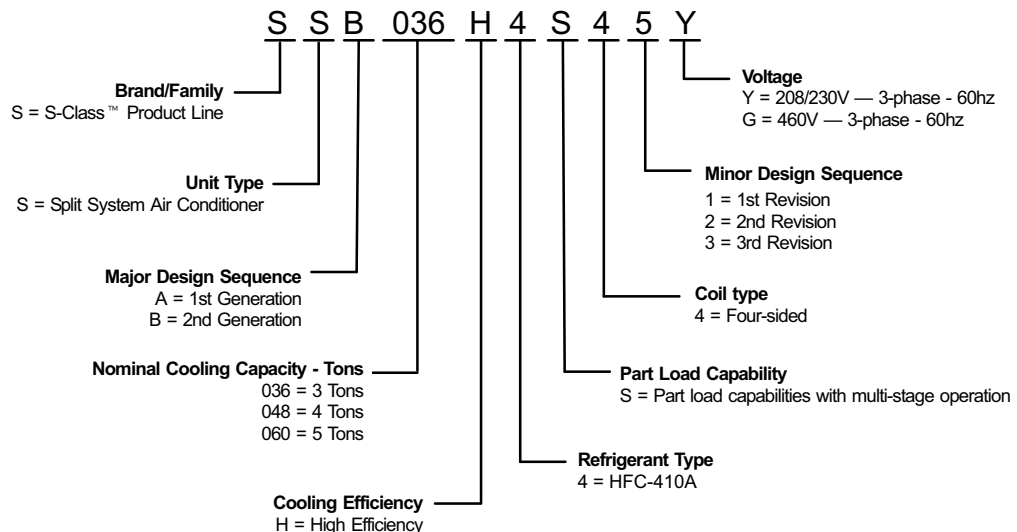

**SPECIFICATIONS — SSBXXH4S41Y/G and SSBXXH4S42Y/G**

<b>General Data</b>	<b>Model No.</b>	<b>SSB036H4</b>	<b>SSB048H4</b>	<b>SSB060H4</b>
	Nominal Tonnage	3	4	5
<b>Connections (sweat)</b>	Liquid line (o.d.) - in.	3/8	3/8	3/8
	Suction line (o.d.) - in.	7/8	7/8	1-1/8
<b>Refrigerant</b>	<sup>1</sup> R-410A charge furnished	8 lb. 9 oz.	11 lb. 4 oz.	14 lb. 2 oz.
<b>Outdoor Coil</b>	Net face area - sq. ft. Outer coil	16.33	21.00	24.93
	Inner coil	15.76	20.27	24.14
	Tube diameter - in.	5/16	5/16	5/16
	No. of rows	2	2	2
	Fins per inch	22	22	22
<b>Outdoor Fan</b>	Diameter - in.	22	22	26
	No. of blades	4	4	3
	Motor hp	1/6	1/4	1/3
	Cfm	3060	3955	4380
	Rpm	845	835	850
	Watts	215	320	280
<b>Shipping Data - lbs. 1 pkg.</b>		229	257	309

**ELECTRICAL DATA**

	Line voltage data - 60hz		208/230V-3ph		460V-3ph		
	208/230V-3ph	460V-3ph	208/230V-3ph	460V-3ph	208/230V-3ph	460V-3ph	
<sup>2</sup> Maximum overcurrent protection (amps)	25	10	30	15	40	20	
<sup>3</sup> Minimum circuit ampacity	15.04	6.20	18.53	9.1	23.83	12.21	
<b>Compressor</b>	Rated load amps	11.15	4.48	13.46	6.41	17.62	8.97
	Locked rotor amps	58	29	88	41	135	62
	Power factor	0.99	0.99	0.99	0.99	0.99	0.99
<b>Outdoor Fan Motor</b>	Full load amps	1.1	0.6	1.7	0.9	1.8	1.0
	Locked Rotor amps	2.1	1.1	3.1	2.1	2.9	2.0

**SPECIFICATIONS — SSBXXH4S43Y/G**

<b>General Data</b>	<b>Model No.</b>	<b>SSB036H4</b>	<b>SSB048H4</b>	<b>SSB060H4</b>
	Nominal Tonnage	3	4	5
<b>Connections (sweat)</b>	Liquid line (o.d.) - in.	3/8	3/8	3/8
	Suction line (o.d.) - in.	7/8	7/8	1-1/8
<b>Refrigerant</b>	<sup>1</sup> R-410A charge furnished	8 lb. 8 oz.	11 lb. 4 oz.	14 lb. 2 oz.
<b>Outdoor Coil</b>	Net face area - sq. ft. Outer coil	24.5	21.00	24.93
	Inner coil	---	20.27	24.14
	Tube diameter - in.	5/16	5/16	5/16
	No. of rows	1	2	2
	Fins per inch	26	22	22
<b>Outdoor Fan</b>	Diameter - in.	22	22	26
	No. of blades	4	4	3
	Motor hp	1/6	1/4	1/3
	Cfm	3060	3955	4380
	Rpm	825	835	850
	Watts	215	320	280
<b>Shipping Data - lbs. 1 pkg.</b>		229	257	309

**ELECTRICAL DATA**

	Line voltage data - 60hz		208/230V-3ph	460V-3ph	208/230V-3ph	460V-3ph	208/230V-3ph	460V-3ph
<sup>2</sup> Maximum overcurrent protection (amps)			25	10	30	15	40	20
<sup>3</sup> Minimum circuit ampacity			15.1	6.20	18.6	9.1	23.9	12.3
<b>Compressor</b>	Rated load amps		11.15	4.48	13.46	6.41	17.62	8.97
	Locked rotor amps		58	29	88	41	135	62
	Power factor		0.99	0.99	0.99	0.99	0.99	0.99
<b>Outdoor Fan Motor</b>	Full load amps		1.1	0.6	1.7	0.9	1.8	1.0
	Locked Rotor amps		2.1	1.1	3.1	2.1	2.9	2.0

## ⚠ IMPORTANT

Operating pressures of this R-410A unit are higher than pressures in R-22 units. Always use service equipment rated for R410A.

### I - APPLICATION

SSB\*H4 condensing units are available in 3, 4 and 5 ton capacities. All major components (indoor blower and coil) must be matched according to Lennox recommendations for the compressor to be covered under warranty. Refer to the Engineering Handbook for approved system matchups.

### II - UNIT COMPONENTS

Unit components are illustrated in figure 1.

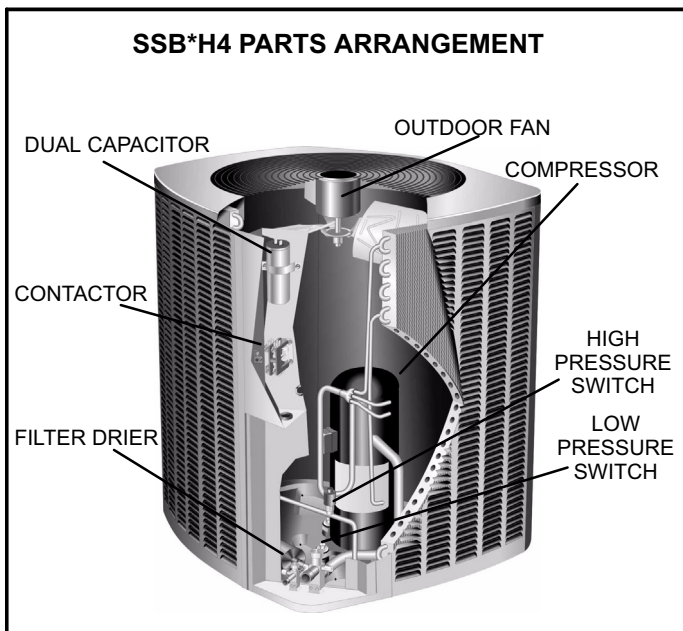

FIGURE 1

## ⚠ CAUTION

To prevent personal injury, or damage to panels, unit or structure, be sure to observe the following:

While installing or servicing this unit, carefully stow all removed panels out of the way, so that the panels will not cause injury to personnel, nor cause damage to objects or structures nearby, nor will the panels be subjected to damage (e.g., being bent or scratched).

While handling or stowing the panels, consider any weather conditions, especially windy conditions, that may cause panels to be blown around and battered.

Remove the louvered panels as follows:

1 - Remove 2 screws, allowing the panel to swing open slightly (see figure 2).

### Removing/Installing Louvered Panels

**IMPORTANT!** Do not allow panels to hang on unit by top tab. Tab is for alignment and not designed to support weight of panel.

Panel shown slightly rotated to allow top tab to exit (or enter) top slot for removing (or installing) panel.

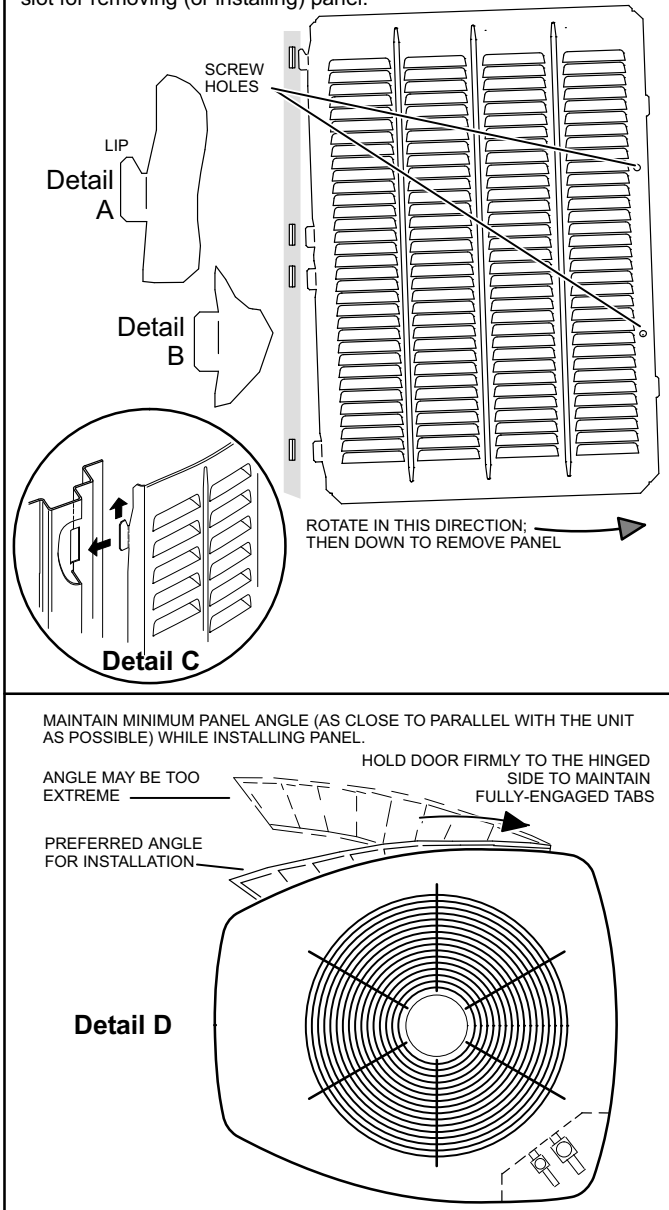

FIGURE 2

2 - Hold the panel firmly throughout this procedure. Rotate bottom corner of panel away from hinge corner post until lower 3 tabs clear the slots (see figure 2, Detail B).

3 - Move panel down until lip of upper tab clears the top slot in corner post (see figure 2, Detail A).

**Position and Install Panel**—Position the panel almost parallel with the unit (figure 2, Detail D) with the “screw side” as close to the unit as possible. Then, in a continuous motion: Slightly rotate and guide the lip of top tab inward (figure 2, Details A and C); then upward into the top slot of the hinge corner post.

Rotate panel to vertical to fully engage all tabs.

Holding the panel’s hinged side firmly in place, close the right-hand side of the panel, aligning the screw holes.

When panel is correctly positioned and aligned, insert the screws and tighten.

### A - Control Box (Figure 3)

SSB\*H4 units are not equipped with a 24V transformer. All 24 VAC controls are powered by the indoor unit. Refer to wiring diagram.

Electrical openings are provided under the control box cover. Field thermostat wiring is made to color-coded pigtail connections.

#### ELECTROSTATIC DISCHARGE (ESD) Precautions and Procedures

### CAUTION

Electrostatic discharge can affect electronic components. Take precautions during unit installation and service to protect the unit's electronic controls. Precautions will help to avoid control exposure to electrostatic discharge by putting the unit, the control and the technician at the same electrostatic potential. Neutralize electrostatic charge by touching hand and all tools on an unpainted unit surface before performing any service procedure.

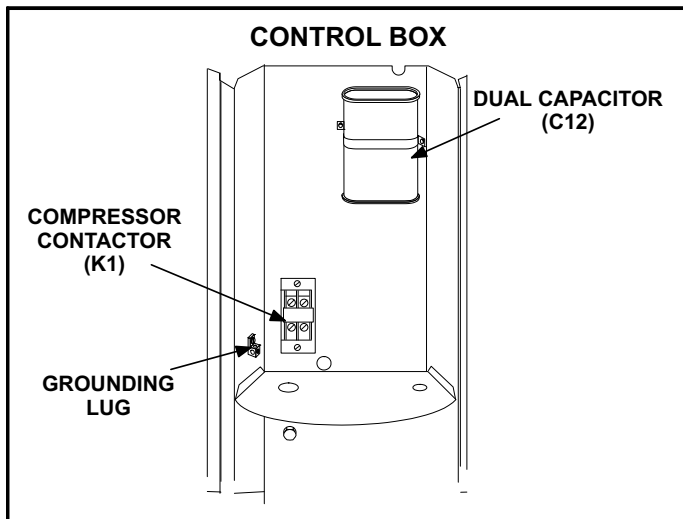

FIGURE 3

### 1 - Compressor Contactor K1

The compressor is energized by a single-pole contactor located in the control box. See figure 3. K1 is energized by the indoor thermostat terminal Y1 (24V) when thermostat demand is present.

### 2 - Dual Capacitor C12

The compressor and fan in SSB\*H4 series units use permanent split capacitor motors. The capacitor is located inside the unit control box (see figure 3). A single "dual" capacitor (C12) is used for both the fan motor and the compressor (see unit wiring diagram). The fan side and the compressor side of the capacitor have different MFD ratings. See side of capacitor for ratings.

### CAUTION

In order to avoid injury, take precaution when lifting heavy objects.

### B - Two-Stage Scroll Compressor (B1)

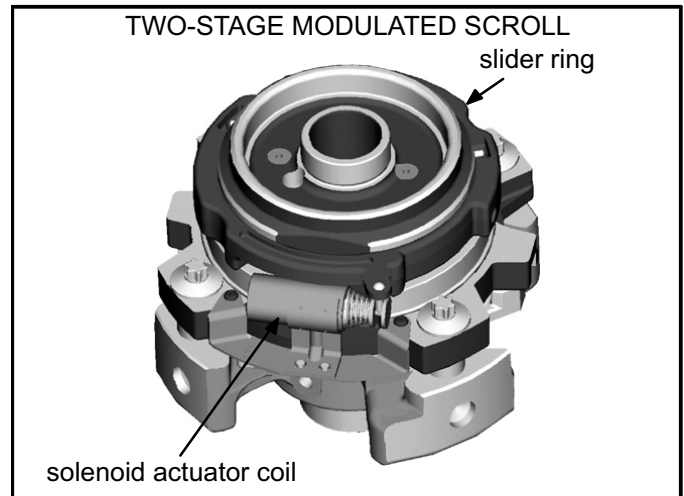

FIGURE 1

The scroll compressor design is simple, efficient and requires few moving parts. A cutaway diagram of the scroll compressor is shown in figure 1. The scrolls are located in the top of the compressor can and the motor is located just below. The oil level is immediately below the motor.

The scroll is a simple compression concept centered around the unique spiral shape of the scroll and its inherent properties. Figure 2 shows the basic scroll form. Two identical scrolls are mated together forming concentric spiral shapes (figure 3). One scroll remains stationary, while the other is allowed to "orbit" (figure 4). Note that the orbiting scroll does not rotate or turn but merely "orbits" the stationary scroll.

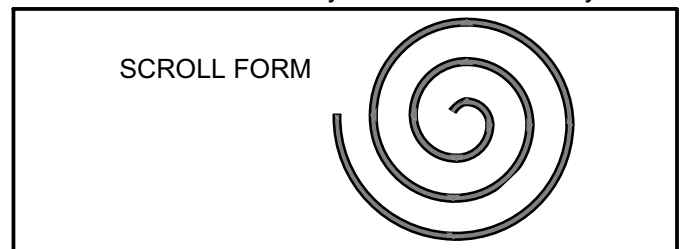

FIGURE 2

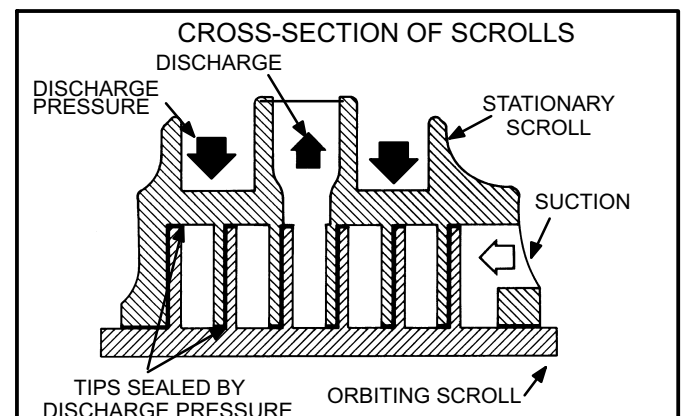

FIGURE 3

The counterclockwise orbiting scroll draws gas into the outer crescent shaped gas pocket created by the two scrolls (figure 4 - 1). The centrifugal action of the orbiting scroll seals off the flanks of the scrolls (figure 4 - 2). As the orbiting motion continues, the gas is forced toward the center of the scroll and the gas pocket becomes compressed (figure 4 -3). When the compressed gas reaches the center, it is discharged vertically into a chamber and discharge port in the top of the compressor (figure 1). The discharge pressure forcing down on the top scroll helps seal off the upper and lower edges (tips) of the scrolls (figure 3 ). During a single orbit, several pockets of gas are compressed simultaneously providing smooth continuous compression.

The scroll compressor is tolerant to the effects of liquid return. If liquid enters the scrolls, the orbiting scroll is allowed to separate from the stationary scroll. The liquid is worked toward the center of the scroll and is discharged. If the compressor is replaced, conventional Lennox cleanup practices must be used.

Due to its efficiency, the scroll compressor is capable of drawing a much deeper vacuum than reciprocating compressors. Deep vacuum operation can cause internal fuse arcing resulting in damaged internal parts and will result in compressor failure. This type of damage can be detected and will result in denial of warranty claims. The scroll compressor can be used to pump down refrigerant as long as the pressure is not reduced below 7 psig.

*NOTE - During operation, the head of a scroll compressor may be hot since it is in constant contact with discharge gas.*

The scroll compressors in all HSXA19 model units are de-

signed for use with R410A refrigerant and operation at high pressures. Compressors are shipped from the factory with 3MA (32MMMA) P.O.E. oil. See electrical section in this manual for compressor specifications.

### TWO-STAGE OPERATION

The two-stage scroll compressor operates like any standard scroll compressor with the exception the two-stage compressor modulates between first stage (low capacity approximately 67%) and second stage (high capacity). Modulation occurs when gas is bypassed through bypass ports (figure 5 bypass ports open) in the first suction pocket. This bypassing of gas allows the compressor to operate on first stage (low capacity) if thermostat demand allows. Indoor thermostat setting will determine first or second stage operation. The compressor will operate on first-stage until demand is satisfied or the indoor temperature reaches the thermostat set point calling for second-stage.

Second-stage (high capacity) is achieved by blocking the bypass ports (figure 5 bypass ports closed) with a slider ring. The slider ring begins in the open position and is controlled by a **24VDC** internal solenoid. On a Y2 call the internal solenoid closes the slider ring, blocking the bypass ports and bringing the compressor to high capacity. Two-stage modulation can occur during a single thermostat demand as the motor runs continuously while the compressor modulates from first-stage to second- stage.

*NOTE - During operation, the head of a scroll compressor may be hot since it is in constant contact with discharge gas.*

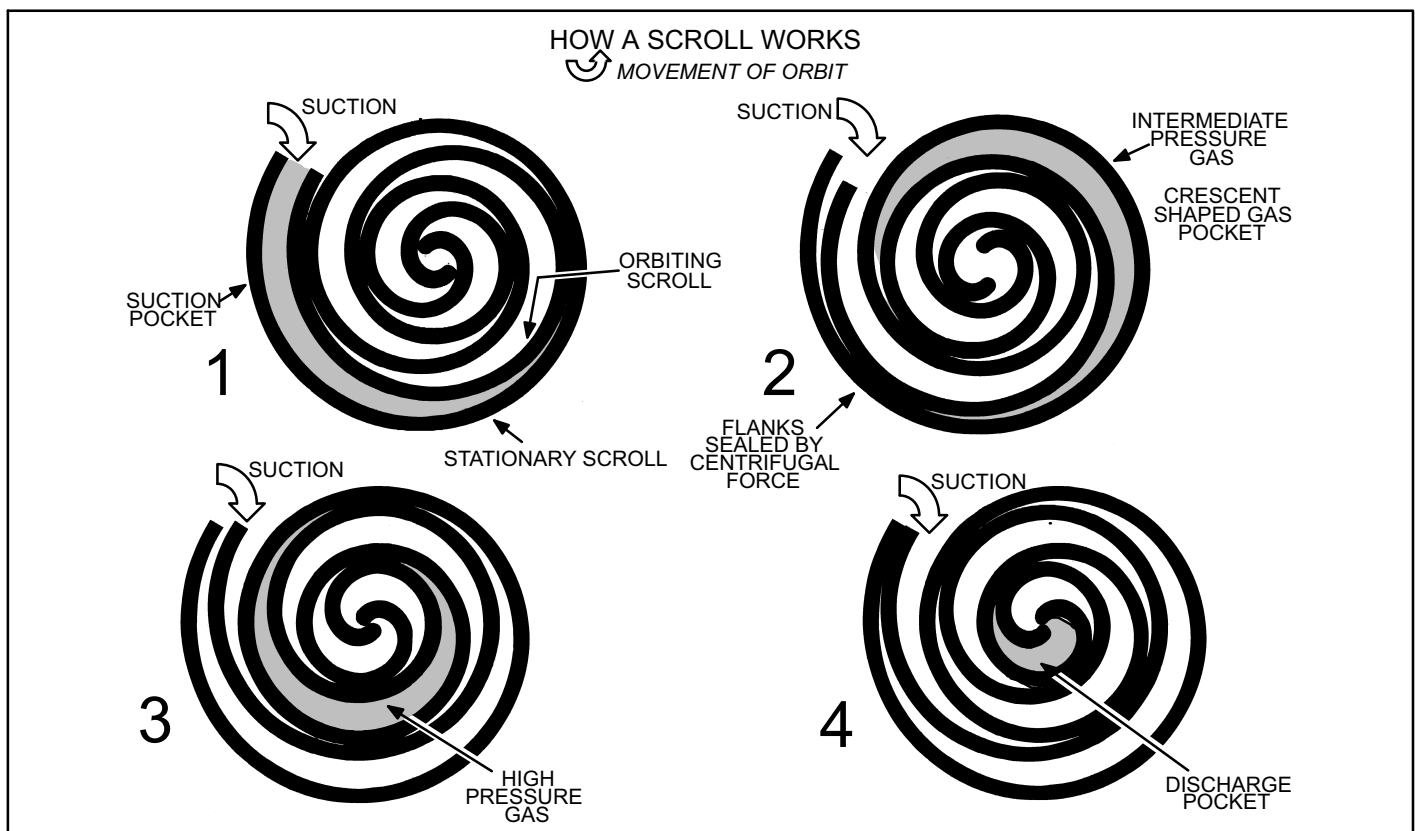
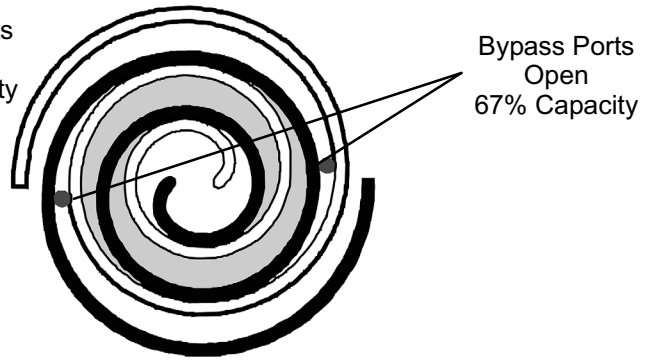
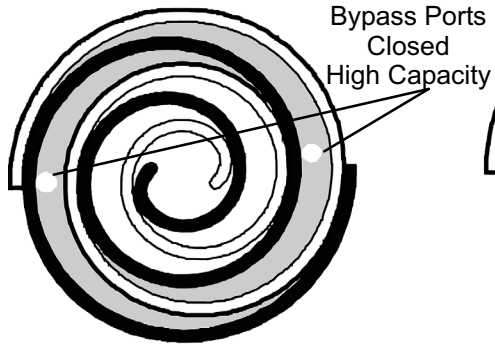

FIGURE 4

**TWO STAGE MODULATION**



**FIGURE 5**

## INTERNAL SOLENOID (L34)

The internal unloader solenoid controls the two-stage operation of the compressor by shifting a slide ring mechanism to open two by-pass ports in the first compression pocket of the scrolls in the compressor. The internal solenoid is activated by a **24 volt direct current solenoid coil**. The coil power requires 20VAC. The internal wires from the solenoid in the compressor are routed to a 2 pin fusite connection on the side of the compressor shell. The external electrical connection is made to the compressor with a molded plug assembly. This plug contains a full wave rectifier that converts 24 volt AC into 24 volt DC power to power the unloader solenoid. Refer to unit diagram for internal circuitry view of plug).

If it is suspect the unloader is not operating properly, check the following

### **IMPORTANT**

**This performance check is ONLY valid on systems that have clean indoor and outdoor coils, proper air-flow over coils, and correct system refrigerant charge. All components in the system must be functioning proper to correctly perform compressor modulation operational check. (Accurate measurements are critical to this test as indoor system loading and outdoor ambient can affect variations between low and high capacity readings).**

#### **STEP 1 Confirm low to high capacity compressor operation**

##### **Tools required**

Refrigeration gauge set

Digital volt/amp meter

Electronic temperature thermometer

On-off toggle switch

## **Procedure**

- 1 - Turn main power "OFF" to outdoor unit.
- 2 - Adjust room thermostat set point above (heating operation on heat pump) or below (cooling operation) the room temperature 5°F.
- 3 - Remove control access panel. Install refrigeration gauges on unit. Attach the amp meter to the common (black wire) wire of the compressor harness. Attach thermometer to discharge line as close as possible to the compressor.
- 4 - Turn toggle switch "OFF" and install switch in series with Y2 wire from room thermostat.
- 5 - Cycle main power "ON."
- 6 - Allow pressures and temperatures to stabilize before taking any measured reading (may take up to 10 minutes).

*NOTE - Block outdoor coil to maintain a minimum of 375 psig during testing).*

- 7 - Record all of the readings for the Y1 demand on table 1.
- 8 - Close switch to energize Y2 demand.
- 9 - Allow pressures and temperatures to stabilize before taking any measured reading (this may take up to 10 minutes).
- 10 - Record all of the readings of Y2 demand on table 1.

*NOTE - On new installations or installations that have shut down for an extended period of time, if the compressor does not cycle from low stage to high stage on the first attempt, it may be necessary to recycle the compressor back down to low stage and back up to high stage a few times in order to get the bypass seals to properly seat. Compare Y1 readings with Y2 readings in table 1. Some readings should be higher, lower or the same. If the readings follow what table 1 specifies, the compressor is operating and shifting to high capacity as designed. If the readings do not follow what table 1 specifies, continue to step 2 to determine if problem is with external solenoid plug power.*

TABLE 1

Unit Readings	Cooling Operation		
	Y1 - 1st-Stage	Expected Results	Y2 - 2nd-Stage
<b>Compressor</b>			
Voltage		Same	
Amperage		Higher	
<b>Condenser Fan motor</b>			
Amperage		Same or Higher	
<b>Temperature</b>			
Ambient		Same	
Outdoor Coil Discharge Air		Higher	
Compressor Discharge Line		Higher	
Indoor Return Air		Same	
Indoor Coil Discharge Air		Lower	
<b>Pressures</b>			
Suction (Vapor)		Lower	
Liquid		Higher	

**STEP 2 Confirm DC voltage output on compressor solenoid plug**

- 1 - Shut power off to outdoor unit.
- 2 - Supply 24 volts AC control voltage to the wire ends of the full wave rectifier plug. Listen for a “click” as the solenoid is energized. See figure 6.

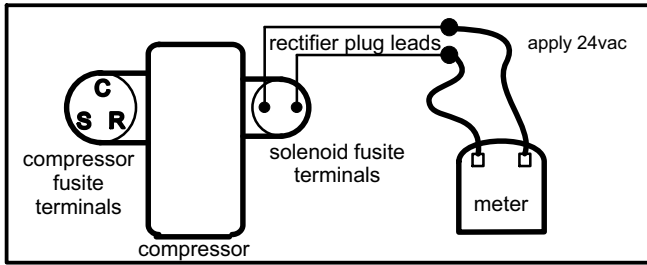

FIGURE 6

- 3 - Unplug the full wave rectifier plug from the fusite connection on the compressor.
- 4 - Turn the low voltage power back onto the unit. Supply 24VAC to the wires of the full wave rectifier plug. Set volt meter to DC volts and measure the DC voltage at the female connector end of the full wave rectifier plug. The DC voltage reading should be 1.5 to 3 volts lower than the input voltage to the plug wire leads. (EX: Input voltage is 24VAC output voltage is 22VDC). See figure 7.

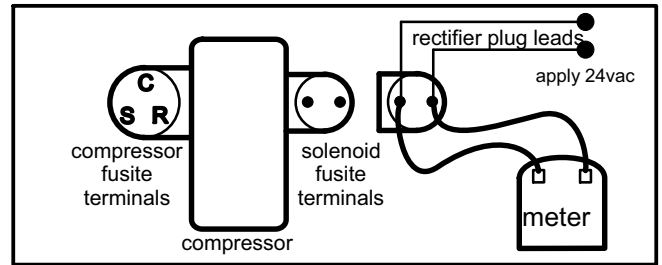

FIGURE 7

If the above checks verify that the solenoid plug is providing power to cycle into high capacity operation, continue to step 3 to determine if problem is with solenoid coil in compressor

**STEP 3 Confirm internal unloader solenoid has proper resistance**

- 1 - Shut all power off to unit (main and low voltage)
- 2 - Unplug the molded plug from the compressor solenoid 2-pin fusite.
- 3 - Using a volt meter set on the 200 ohm scale

**Replace the Compressor under these conditions:**

**Bad Solenoid**

- a. Measure the resistance at the 2-pin fusite. The resistance should be 32 to 60 ohms depending on compressor temperature. If no resist ancereplace compressor.
- b. Measure the resistance from each fusite pin to ground. There should **not be** continuity to ground. If solenoid coil is grounded, replace compressor.

**Good Solenoid**

- a. Seals not shifting, replace compressor
- b. Slider ring not shifting, replace compressor.

## C - Condenser Fan Motor

All units use single-phase PSC fan motors which require a run capacitor. In all units, the condenser fan is controlled by the compressor contactor.

ELECTRICAL DATA tables in this manual show specifications for condenser fans used in SSB\*H4's.

Access to the condenser fan motor on all units is gained by removing the four screws securing the fan assembly. See figure 4. The grill fan assembly can be removed from the cabinet as one piece. See figure 5. The condenser fan motor is removed from the fan guard by removing the four nuts found on top of the grill. See figure 5 if condenser fan motor replacement is necessary.

### **⚠ DANGER**

**Make sure all power is disconnected before beginning electrical service procedures.**

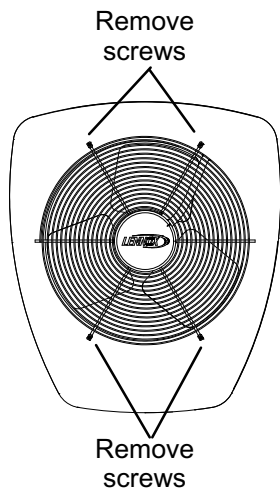

**FIGURE 4**

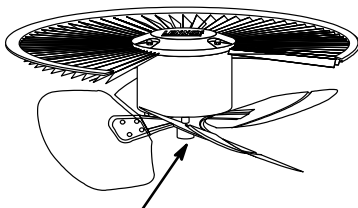

**FIGURE 5**

### **⚠ IMPORTANT**

**Pressure switch settings for R-410A refrigerant will be significantly higher than units with R-22.**

## D - Low Pressure Switch

An auto-reset, single-pole/single-throw low pressure switch is located in the suction line. This switch shuts off the compressor when suction pressure drops below the factory setting. The switch is closed during normal operating pressure conditions and is permanently adjusted to trip (open) at  $40 \pm 5$  psi. The switch automatically resets when suction line pressure rises above  $90 \pm 5$  psi. Under certain conditions the low pressure switch is ignored.

## E - High Pressure Switch

A manual-reset, single-pole/single-throw low pressure switch is located in the liquid line. The switch is closed during normal operating pressure conditions. The switch removes power from the compressor contactor control circuit when discharge pressure rises above factory setting at  $590 \pm 10$  psi.

## F - Crankcase Heater (HR1) & Thermostat (S40)

Some units are equipped with a 70 watt, belly band type crankcase heater. HR1 prevents liquid from accumulating in the compressor. HR1 is controlled by a thermostat located on the liquid line. When liquid line temperature drops below  $50^\circ$  F the thermostat closes energizing HR1. The thermostat will open, de-energizing HR1 once liquid line temperature reaches  $70^\circ$  F.

## G - Crankcase Heater Relay K191 (G Voltage)

All 460 volt SSB units require the S40 thermostat to be wired in series with the 24 volt coil of the K191 relay. The contacts of the K191 control operation of crankcase heater HR1. When ambient temperature drops below  $50^\circ$  F, K191 contacts close energizing HR1. When the ambient temperature rises to  $70^\circ$  F the contacts open de-energizing HR1.

## H - Drier

A filter drier designed for all XC16 model units is factory installed in the liquid line. The filter drier is designed to remove moisture and foreign matter, which can lead to compressor failure.

### Moisture and / or Acid Check

Because POE oils absorb moisture, the dryness of the system must be verified any time the refrigerant system is exposed to open air. A compressor oil sample must be taken to determine if excessive moisture has been introduced to the oil. Table 2 lists kits available from Lennox to check POE oils.

If oil sample taken from a system that has been exposed to open air does not test in the dry color range, the filter drier **MUST** be replaced.

## **! IMPORTANT**

**Replacement filter drier **MUST** be approved for R-410A refrigerant and POE application.**

### Foreign Matter Check

It is recommended that a liquid line filter drier be replaced when the pressure drop across the filter drier is greater than 4 psig.

**TABLE 2**

KIT	CONTENTS	TUBE SHELF LIFE
10N46 - Refrigerant Analysis	Checkmate-RT700	
10N45 - Acid Test Tubes	Checkmate-RT750A (three pack)	2 - 3 years @ room temperature. 3+ years refrigerated
10N44 - Moisture Test Tubes	Checkmate - RT751 Tubes (three pack)	6 - 12 months @ room temperature. 2 years refrigerated
74N40 - Easy Oil Test Tubes	Checkmate - RT752C Tubes (three pack)	2 - 3 years @ room temperature. 3+ years refrigerated
74N39 - Acid Test Kit	Sporlan One Shot - TA-1	

### MEASURING FILTER DRIER PRESSURE DROP

- 1- Shut off power to unit.
- 2- Remove high pressure switch from fitting next to filter drier. (A schrader core is located under the high pressure switch).
- 3- Install high pressure gauge hose onto high pressure switch fitting.
- 4- Turn power on to unit and turn room thermostat to call for cooling.
- 5- Record pressure reading on gauge.
- 6- Remove hose from high pressure fitting and install on liquid line valve.
- 7- Read liquid line valve pressure.
- 8- High pressure fitting pressure - liquid line valve pressure = filter drier pressure drop.
- 9- If pressure drop is greater than 4 psig replace filter drier. See figure 9.
- 10- Re-install high pressure switch.

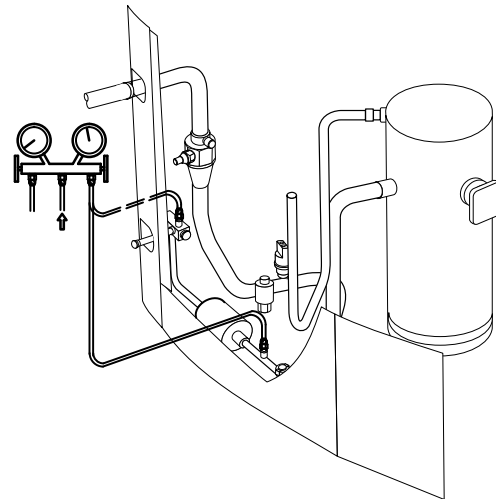

**FIGURE 8**

### REPLACING FILTER DRIER

- 1- Recover all refrigerant from unit.
- 2- Remove original filter drier.
- 3- Install new filter drier in existing location or alternate location as shown. *Proper brazing procedures should be followed.*
- 4- Evacuate system. See section IV - sub-section B - .
- 5- Recharge system. See section IV - sub-section C - .

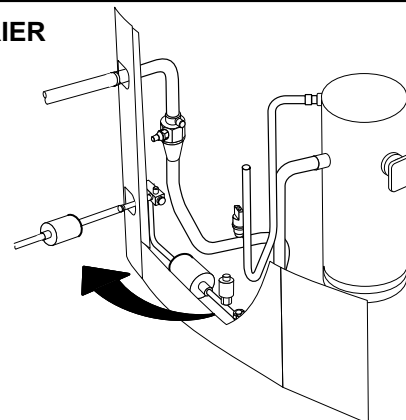

**FIGURE 9**

### III - REFRIGERANT SYSTEM

#### A - Plumbing

Field refrigerant piping consists of liquid and suction lines from the condensing unit (sweat connections) to the indoor evaporator coil (sweat connections). Use Lennox L15 (sweat) series line sets as shown in table 3.

**TABLE 3**

Unit	Liquid Line	Suction Line	L15 Line Sets
-036, -048	3/8 in. (10 mm)	7/8 in. (22 mm)	L15-65 15 ft. - 50 ft. (4.6 m - 15 m)
-060	3/8 in. (10 mm)	1-1/8 in. (29 mm)	Field Fabricated

The liquid line and vapor line service valves (figures 6 and 7) and gauge ports are accessible from the outside of the unit. Use the service ports for leak testing, evacuating, charging and checking charge.

Each valve is equipped with a service port which has a factory-installed Schrader valve. A service port cap protects the Schrader valve from contamination and serves as the primary leak seal. *Service valves are not rebuildable. If a valve has failed, you must replace it.*

#### To Access Schrader Port:

- 1 - Remove service port cap with an adjustable wrench.
- 2 - Connect gauge to the service port.
- 3 - When testing is complete, replace service port cap. Tighten finger tight, then an additional 1/6 turn.

#### To Open Service Valve:

- 1 - Remove the stem cap with an adjustable wrench.
- 2 - Using the adjustable wrench to keep the valve stationary, use a service wrench with a hex-head extension to back the stem out counterclockwise as far as it will go.  
*NOTE - Use a 3/16" hex head extension for 3/8" line sizes or a 5/16" extension for large line sizes.*
- 3 - Replace the stem cap. Tighten finger tight, then tighten an additional 1/6 turn.

#### To Close Service Valve:

- 1 - Remove the stem cap with an adjustable wrench.
- 2 - Using the adjustable wrench to keep the valve stationary, use a service wrench with a hex-head extension to turn the stem clockwise to seat the valve. Tighten the stem firmly.

*NOTE - Use a 3/16" hex head extension for 3/8" line sizes or a 5/16" extension for large line sizes.*

- 3 - Replace the stem cap. Tighten finger tight, then tighten an additional 1/6 turn.

*NOTE - Stem cap must be replaced to help prevent valve leakage.*

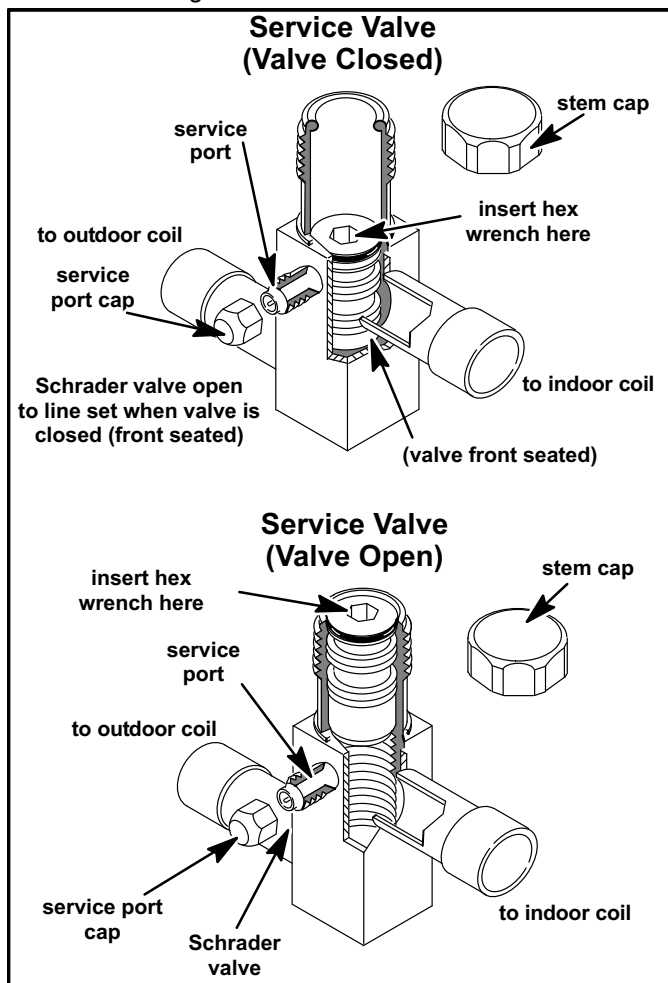

**FIGURE 6**

#### Vapor Line Ball Valve – 5 Ton Units Only

Vapor line service valves function the same way as the other valves, the difference is in the construction. A ball valve is illustrated in figure 7.

The ball valve is equipped with a service port with a factory-installed Schrader valve. A service port cap protects the Schrader valve from contamination and assures a leak-free seal.

### Ball Valve (Valve Open)

Use Adjustable Wrench  
To open: rotate Stem Clockwise 90°.  
To close: rotate Stem Counter-clockwise 90°.

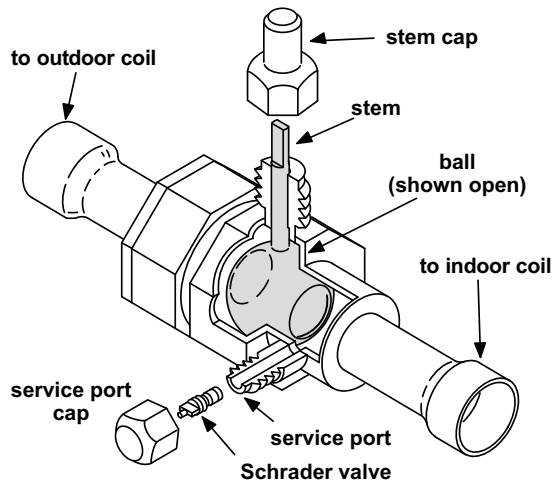

FIGURE 7

## IV - CHARGING

### ⚠ WARNING

R-410A refrigerant can be harmful if it is inhaled. R-410A refrigerant must be used and recovered responsibly.

Failure to follow this warning may result in personal injury or death.

#### A - Leak Testing

After the line set has been connected to the indoor and outdoor units, check the line set connections and indoor unit for leaks.

### ⚠ IMPORTANT

The Clean Air Act of 1990 bans the intentional venting of (CFC's and HFC's) as of July 1, 1992. Approved methods of recovery, recycling or reclaiming must be followed. Fines and/or incarceration may be levied for noncompliance.

### ⚠ WARNING



Fire, Explosion and Personal Safety Hazard.

Failure to follow this warning could result in damage, personal injury or death.

Never use oxygen to pressurize or purge refrigeration lines. Oxygen, when exposed to a spark or open flame, can cause damage by fire and / or an explosion, that can result in personal injury or death.

### ⚠ WARNING



Danger of explosion!

When using a high pressure gas such as dry nitrogen to pressurize a refrigerant or air conditioning system, use a regulator that can control the pressure down to 1 or 2 psig (6.9 to 13.8 kPa).

#### Using an Electronic Leak Detector

- 1 - Connect a cylinder of R-410A to the center port of the manifold gauge set. Connect manifold gauge to service valve port.
- 2 - With both manifold valves closed, open the valve on the R-410A cylinder.
- 3 - Open the high pressure side of the manifold to allow the R-410A into the line set and indoor unit. Weigh in a trace amount of R-410A. [A trace amount is a maximum of 2 ounces (57 g) or 3 pounds (31 kPa) pressure.] Close the valve on the R-410A cylinder and the valve on the high pressure side of the manifold gauge set. Disconnect the R-410A cylinder.
- 4 - Connect a cylinder of nitrogen with a pressure regulating valve to the center port of the manifold gauge set.
- 5 - Connect the manifold gauge set high pressure hose to the vapor valve service port. (Normally, the high pressure hose is connected to the liquid line port; however, connecting it to the vapor port better protects the manifold gauge set from high pressure damage.)
- 6 - Adjust the nitrogen pressure to 150 psig (1034 kPa). Open the valve on the high side of the manifold gauge set which will pressurize line set and indoor unit.
- 7 - After a few minutes, open a refrigerant port to ensure the refrigerant you added is adequate to be detected. (Amounts of refrigerant will vary with line lengths.) Check all joints for leaks. Purge nitrogen and R-410A mixture. Correct any leaks and recheck.

#### B - Evacuating

Evacuating the system of noncondensables is critical for proper operation of the unit. Noncondensables are defined as any gas that will not condense under temperatures and pressures present during operation of an air conditioning system. Noncondensables and water vapor combine with refrigerant to produce substances that corrode copper piping and compressor parts.

*NOTE - This evacuation process is adequate for a new installation with clean and dry lines. If excessive moisture is present, the evacuation process may be required more than once.*

### ⚠ IMPORTANT

Use a thermocouple or thermistor electronic vacuum gauge that is calibrated in microns. Use an instrument that reads from 50 microns to at least 10,000 microns.

- 1 - Connect manifold gauge set to the service valve ports :
  - low pressure gauge to *vapor* line service valve
  - high pressure gauge to *liquid* line service valve
- 2 - Connect micron gauge.
- 3 - Connect the vacuum pump (with vacuum gauge) to the center port of the manifold gauge set.
- 4 - Open both manifold valves and start the vacuum pump.
- 5 - Evacuate the line set and indoor unit to an **absolute pressure** of 23,000 microns (29.01 inches of mercury). During the early stages of evacuation, it is desirable to close the manifold gauge valve at least once to determine if there is a rapid rise in **absolute pressure**. A rapid rise in pressure indicates a relatively large leak. If this occurs, repeat the leak testing procedure.

*NOTE - The term **absolute pressure** means the total actual pressure within a given volume or system, above the absolute zero of pressure. Absolute pressure in a vacuum is equal to atmospheric pressure minus vacuum pressure.*

- 6 - When the absolute pressure reaches 23,000 microns (29.01 inches of mercury), close the manifold gauge valves, turn off the vacuum pump and disconnect the manifold gauge center port hose from vacuum pump. Attach the manifold center port hose to a nitrogen cylinder with pressure regulator set to 150 psig (1034 kPa) and purge the air from the hose with nitrogen. Open the manifold gauge valves to break the vacuum in the line set and indoor unit. Close the manifold gauge valves.

## CAUTION

**Danger of Equipment Damage. Avoid deep vacuum operation. Do not use compressors to evacuate a system. Extremely low vacuums can cause internal arcing and compressor failure. Damage caused by deep vacuum operation will void warranty.**

- 7 - Shut off the nitrogen cylinder and remove the manifold gauge hose from the cylinder. Open the manifold gauge valves to release the nitrogen from the line set and indoor unit.
- 8 - Reconnect the manifold gauge to the vacuum pump, turn the pump on, and continue to evacuate the line set and indoor unit until the absolute pressure does not rise above 500 microns (29.9 inches of mercury) within a 20-minute period after shutting off the vacuum pump and closing the manifold gauge valves.
- 9 - When the absolute pressure requirement above has been met, disconnect the manifold hose from the vacuum pump and connect it to an upright cylinder of R-410A refrigerant. Open the manifold gauge valves to break the

vacuum from 1 to 2 psig positive pressure in the line set and indoor unit. Close manifold gauge valves and shut off the R-410A cylinder and remove the manifold gauge set.

## C - Charging

### NOTES -

- R-410A refrigerant cylinders are rose-colored. Refrigerant should be added through the vapor valve in the liquid state.
- Certain R-410A cylinders are identified as being equipped with a dip tube. These allow liquid refrigerant to be drawn from the bottom of the cylinder without inverting the cylinder. DO NOT turn this type cylinder upside-down to draw refrigerant.

## IMPORTANT

**Use table 7 to perform maintenance checks. Table 7 is not a procedure for charging the system. Minor variations in these pressures may be due to differences in installations. Significant deviations could mean that the system is not properly charged or that a problem exists with some component in the system.**

This system is charged with R-410A refrigerant which operates at much higher pressures than R-22. The installed liquid line filter drier is approved for use with R-410A. Do not replace it with components designed for use with R-22. This unit is NOT approved for use with coils which use capillary tubes as a refrigerant metering device.

### Factory Charge

Units are factory charged with the amount of R-410A refrigerant indicated on the unit rating plate. This charge is based on a matching indoor coil and outdoor coil with 15 ft. (4.6 m) line set. For varying lengths of line set, refer to table 4 for refrigerant charge adjustment.

TABLE 4

Refrigerant Charge per Line Set Lengths	
Liquid Line Set Diameter	Oz. per 5 ft. (g per 1.5 m) adjust from 15 ft. (4.6 m) line set*
3/8 in. (9.5 mm)	3 ounce per 5 ft. (85 g per 1.5 m)
<i>*If line length is greater than 15 ft. (4.6 m), add this amount. If line length is less than 15 ft. (4.6 m), subtract this amount.</i>	

## IMPORTANT

**Mineral oils are not compatible with R-410A. If oil must be added, it must be a polyol ester oil. The compressor is charged with sufficient polyol ester oil for approved line set lengths.**

### Units Delivered Void of Charge

**If the system is void of refrigerant**, clean the system using the procedure described below.

- 1 - Use dry nitrogen to pressurize the system and check for leaks. Repair leaks, if possible.

- 2 - Evacuate the system to remove as much of the moisture as possible. Use dry nitrogen to pressurize the system and check for leaks. Repair leaks, if possible.
- 3 - Use dry nitrogen to break the vacuum and install the provided filter drier in the system.
- 4 - Evacuate the system again. Then, weigh the appropriate amount of R-410A refrigerant (listed on unit nameplate) into the system.
- 5 - Monitor the system to determine the amount of moisture remaining in the oil. Use test kit 10N46 to verify that the moisture content is within the kit's dry color range. It may be necessary to replace the filter drier several times to achieve the required dryness level. **If system dryness is not verified, the compressor will fail in the future.**

### Checking Charge — SSBXXXH4S41Y/G and SSBXXXH4S42Y/G

The outdoor unit should be charged during warm weather. However, applications arise in which charging must occur in the colder months. *The method of charging is determined by the unit's refrigerant metering device and the outdoor ambient temperature.*

Measure the liquid line temperature and the outdoor ambient temperature as outlined below:

- 1 - Connect the manifold gauge set to the service valves:
  - low pressure gauge to *vapor* valve service port
  - high pressure gauge to *liquid* valve service port
- 2 - Close manifold gauge set valves. Connect the center manifold hose to an upright cylinder of R-410A .
- 3 - Set the room thermostat to call for heat. This will create the necessary load for properly charging the system in the cooling cycle.
- 4 - Record outdoor ambient temperature using a digital thermometer.
- 5 - When the heating demand has been satisfied, switch the thermostat to cooling mode with a set point of 68°F (20°C). When pressures have stabilized, use a digital thermometer to record the liquid line temperature.
- 6 - The outdoor temperature will determine which charging method to use. Proceed with the appropriate charging procedure.

### Charge Using Weigh-in Method, Fixed Orifice or TXV Systems—Outdoor Temp. < 64°F (17.7°C)

If the system is void of refrigerant, or if the outdoor ambient temperature is cool, first, locate and repair any leaks and then weigh in the refrigerant charge into the unit.

- 1 - Recover the refrigerant from the unit.
- 2 - Conduct leak check; evacuate as previously outlined.
- 3 - Weigh in the unit nameplate charge. If weighing facilities are not available or if charging the unit during warm weather, use one of the following procedures.

### Charge Using the Subcooling Method – Outdoor Temperature ≥ 65°F (18.3°C)

Use the subcooling method to charge the unit. Values from (table 9) are used for this procedure.

If necessary, restrict air flow through the outdoor coil to achieve pressures in the 325-375 psig (2240-2585 kPa) range. Higher pressures are necessary for checking the charge. Block equal sections of air intake panels and move obstructions sideways until the liquid pressure is in the 325-375 psig (2240-2585 kPa) range. See figure 10.

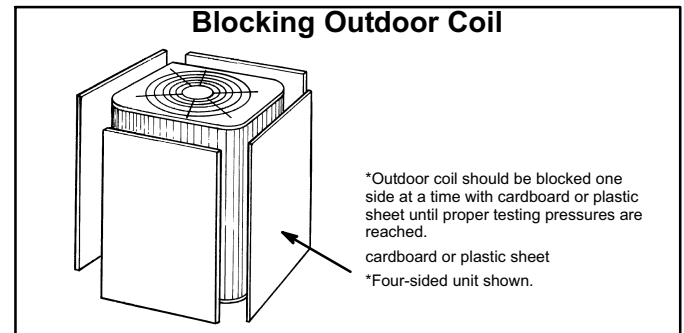

**FIGURE 10**

- 1 - With the manifold gauge hose still on the liquid service port and the unit operating stably, use a digital thermometer to record the liquid line temperature.
- 2 - At the same time, record the liquid line pressure reading.
- 3 - Use a temperature/pressure chart (table 9) to determine the saturation temperature for the liquid line pressure reading.
- 4 - Subtract the liquid line temperature from the saturation temperature (according to the chart) to determine subcooling.

5 - Compare the subcooling value with those in table 5. If subcooling is greater than shown, recover some refrigerant. If subcooling is less than shown, add some refrigerant. Be aware of the HFC-410A refrigerant cylinder. It will be light maroon-colored. Refrigerant should be added through the vapor line valve in the liquid state.

**TABLE 5**

<b>SSB*H4 Subcooling Values for Charging Second Stage (High-Capacity)</b>			
_____ ° Saturation Temperature — _____ ° Liquid Line Temperature = _____ ° Subcooling Value			
Model	SPB036H4S41	SPB048H4S41	SPB060H4S41
°F (°C)*	6 (3.3)	6 (3.3)	9 (5.0)
*F: +/-1.0°; C: +/-0.5°			

**Charge Using the Approach Method, TXV Systems—**  
*Outdoor Temperature ≥ 65°F (18°C)*

*Use the same digital thermometer to check the outdoor ambient temperature and the liquid line temperature.*

The following procedure is intended as a general guide and is for use on expansion valve systems only. For best results, indoor temperature should be 70°F (21°C) to 80°F (26°C). Monitor system pressures while charging.

- 1 - Record outdoor ambient temperature using a digital thermometer.
- 2 - Attach high pressure gauge set and operate unit for several minutes to allow system pressures to stabilize.
- 3 - Compare stabilized pressures with those provided in table 7, "Normal Operating Pressures." Pressures higher than those listed indicate that the system is overcharged. Pressures lower than those listed indicate that the system is undercharged. A temperature/pressure chart for HFC-410A refrigerant is provided in table 9 for your convenience. Verify adjusted charge using the approach method.
- 4 - The difference between the ambient and liquid temperatures should match values given in table 6. If the values don't agree with the those in table 6, add refrigerant to lower the approach temperature, or recover refrigerant from the system to increase the approach temperature. Be aware of the HFC-410A refrigerant cylinder. It will be light maroon-colored. Refrigerant should be added through the vapor valve in the liquid state.

**TABLE 6**

<b>SSB*H4 Approach Values for Charging (Second Stage)</b>			
_____ ° Liquid Line Temperature — _____ ° Outdoor Temperature = _____ ° Approach Temperature			
Model	SSB036H4S41	SSB048H4S41	SSB060H4S41
°F (°C)*	10 (5.6)	8 (4.4)	3 (1.7)
*F: +/-1.0°; C: +/-0.5°			

**⚠ IMPORTANT**

**Table 7 is not a procedure for charging the system but may be used to perform maintenance checks. Minor variations in these pressures may be due to differences in installations. Significant deviations could mean that the system is not properly charged or that a problem exists with some component in the system.**

**TABLE 7**

<b>Normal Operating Pressures In psig (liquid +/- 10 and vapor +/- 5 PSIG)*</b>						
Temp. of air entering outdoor coil °F (°C)	SSB036H4S41		SSB048H4S41		SSB060H4S41	
	Liquid	Suction	Liquid	Suction	Liquid	Suction
<b>First Stage (Low Capacity)</b>						
65 (18.3)	227	137	224	142	215	136
75 (23.9)	261	142	258	144	250	139
85 (29.4)	302	145	299	146	291	142
95 (35.0)	347	147	345	148	337	144
105 (40.6)	396	150	395	150	388	146
115 (46.1)	452	154	450	153	444	148
<b>Second Stage (High Capacity)</b>						
65 (18.3)	244	132	235	135	220	130
75 (23.9)	278	139	269	137	256	133
85 (29.4)	321	142	313	139	299	136
95 (35.0)	368	144	361	141	347	138
105 (40.6)	419	147	412	143	402	141
115 (46.1)	476	150	471	146	462	143
*These are typical pressures only. Indoor indoor match up, indoor air quality, and indoor load will cause the pressures to vary.						

## Checking Charge — SSBXXXH4S43Y/G

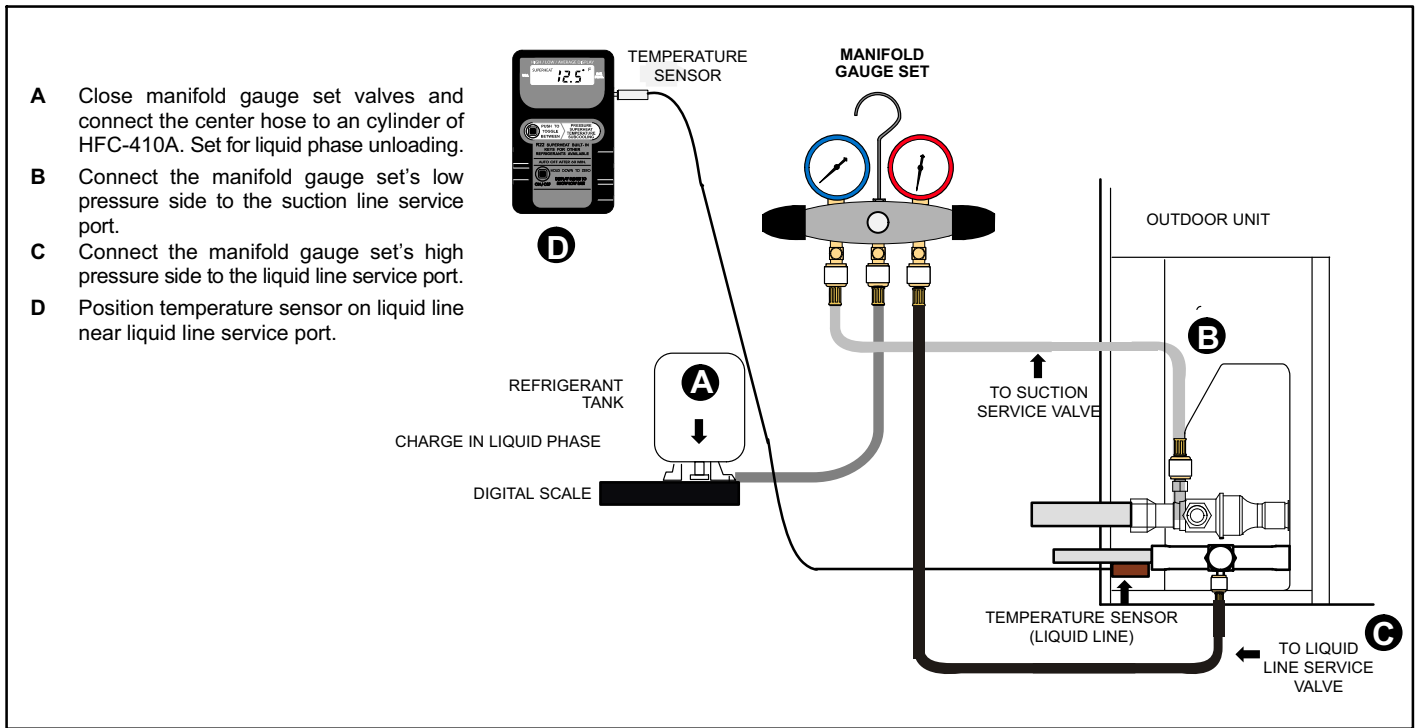

Figure 11. Connecting Gauge Set for Testing and Charging

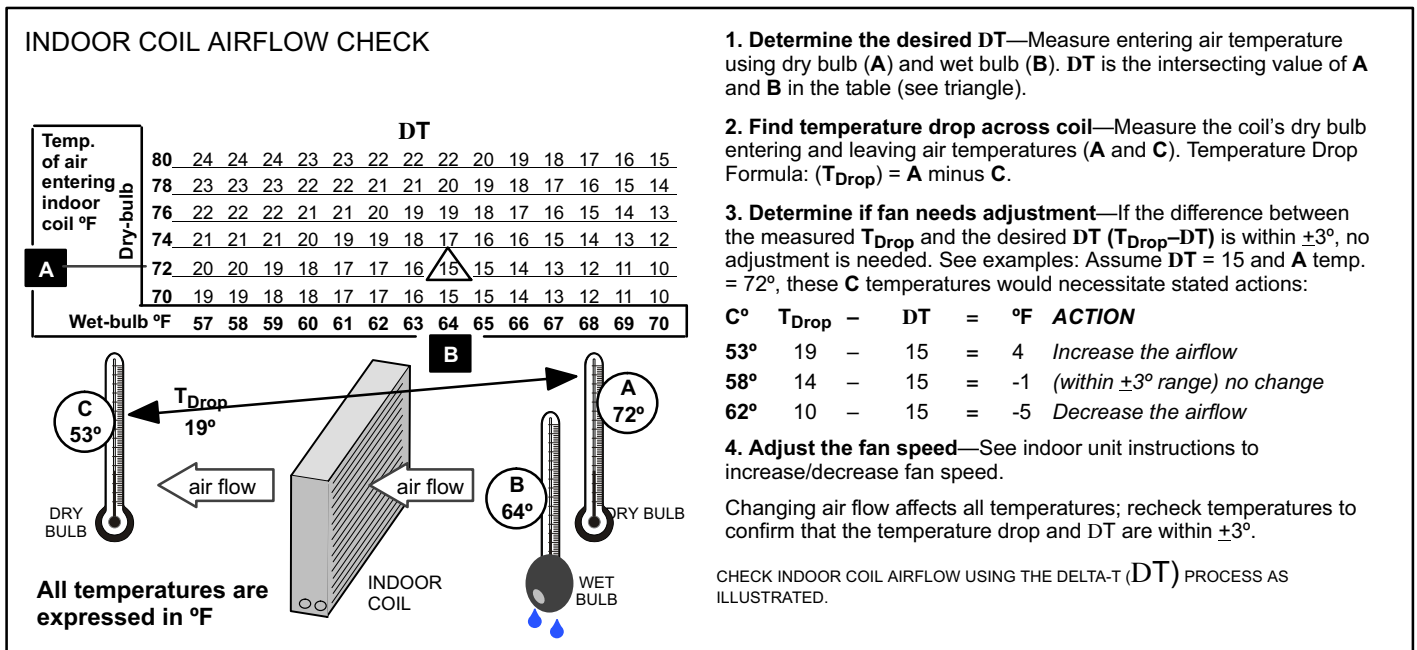

Figure 12. Indoor Coil Airflow Check

# Charging System

## DETERMINING CHARGE METHOD

**START:** Determine how refrigerant is metered

### WHEN TO CHARGE?

- Warm weather best
- Can charge in colder weather

### CHARGE METHOD? Determine by:

- Metering device type
- Outdoor ambient temperature

### REQUIREMENTS:

- Sufficient heat load in structure
- Indoor temperature between 70-80°F (21-26°C)
- Manifold gauge set connected to unit
- Thermometers:
  - to measure outdoor ambient temperature
  - to measure liquid line temperature
  - to measure suction line temperature

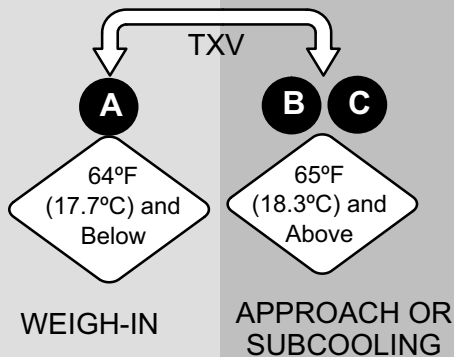

Figure 13. Determining Charge Method

## WEIGH IN CHARGING METHOD 64°F (17.7°C) AND BELOW

### CALCULATING SYSTEM CHARGE FOR OUTDOOR UNIT VOID OF CHARGE

IF THE SYSTEM IS VOID OF REFRIGERANT, FIRST, LOCATE AND REPAIR ANY LEAKS AND THEN WEIGH IN THE REFRIGERANT CHARGE INTO THE UNIT. TO CALCULATE THE TOTAL REFRIGERANT CHARGE:

$$\text{AMOUNT SPECIFIED ON NAMEPLATE} + \text{ADJUST AMOUNT. FOR VARIATION IN LINE SET LENGTH LISTED ON LINE SET LENGTH TABLE BELOW.} = \text{TOTAL CHARGE}$$

#### Refrigerant Charge per Line Set Length

LIQUID LINE SET DIAMETER	OUNCES PER 5 FEET (G PER 1.5 M) ADJUST FROM 15 FEET (4.6 M) LINE SET*
3/8" (9.5 MM)	3 OUNCE PER 5' (85 G PER 1.5 M)

\*IF LINE LENGTH IS GREATER THAN 15 FT. (4.6 M), ADD THIS AMOUNT. IF LINE LENGTH IS LESS THAN 15 FT. (4.6 M), SUBTRACT THIS AMOUNT.

**NOTE** — INSULATE LIQUID LINE WHEN IT IS ROUTED THROUGH AREAS WHERE THE SURROUNDING AMBIENT TEMPERATURE COULD BECOME HIGHER THAN THE TEMPERATURE OF THE LIQUID LINE OR WHEN PRESSURE DROP IS EQUAL TO OR GREATER THAN 20 PSIG.

**NOTE** — THE ABOVE NAMEPLATE IS FOR ILLUSTRATION PURPOSES ONLY. GO TO ACTUAL NAMEPLATE ON OUTDOOR UNIT FOR CHARGE INFORMATION.



Figure 14. Using HFC-410A Weigh In Method

# APPROACH

## TEST AND CHARGE METHOD

65°F (18.3°C) AND ABOVE

IF REFRIGERANT ADDED OR REMOVED, RETEST TO CONFIRM THAT UNIT IS PROPERLY CHARGED



IF VALUE IS GREATER THAN SHOWN (HIGH APPROACH), ADD REFRIGERANT; IF LESS THAN SHOWN (LIQUID TEMP TOO CLOSE TO AMBIENT TEMP, LOW APPROACH), REMOVE REFRIGERANT.



**APP° (APPROACH) VALUES (F: +/-1.0° [C: +/-0.6°])\***

	-036	-048	-060
TEMP*	6 (3.3)	8 (4.4)	4 (2.2)

\*Temperature of air entering outdoor coil is 65°F (18°C) or above.

\* THESE APPROACH VALUES ARE ALSO LISTED ON THE UNIT CHARGING STICKER 580005-01 LOCATED ON THE ACCESS PANEL.

- 1.. CONFIRM PROPER AIRFLOW ACROSS COIL USING FIGURE 12.
- 2.. COMPARE UNIT PRESSURES WITH TABLE 8, *NORMAL OPERATING PRESSURES*.
- 3.. USE APPROACH TO CORRECTLY CHARGE UNIT OR TO VERIFY THE CHARGE IS CORRECT.
- 4.. SET THERMOSTAT TO CALL FOR HEAT (MUST HAVE A COOLING LOAD BETWEEN 70-80°F (21-26°C)).
- 5.. CONNECT GAUGE SET.
- 6.. WHEN HEAT DEMAND IS SATISFIED, SET THERMOSTAT TO CALL FOR COOLING.
- 7.. ALLOW TEMPERATURES AND PRESSURES TO STABILIZE.
- 8.. RECORD OUTDOOR AMBIENT TEMPERATURE:  
**AMB° = \_\_\_\_\_**
- 9.. RECORD LINE TEMPERATURE:  
**LIQ° = \_\_\_\_\_**
- 10.. SUBTRACT TO DETERMINE APPROACH (APP°):  
**LIQ° \_\_\_\_\_ - AMB° \_\_\_\_\_ = APP° \_\_\_\_\_**
- 11.. COMPARE RESULTS WITH TABLE TO THE LEFT.

**Figure 15. Using Approach Test and Charge Method**

# SUBCOOLING

## TEST AND CHARGE METHOD

65°F (18.3°C) AND ABOVE

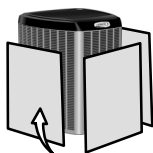

CARDBOARD OR PLASTIC SHEET

**BLOCK OUTDOOR COIL:** [sometimes necessary with lower temperatures] Use cardboard or plastic sheet to restrict the airflow through the outdoor coil to achieve pressures from 325-375 psig (2240-2585 kPa). Higher pressures are needed to check charge. Block equal sections of air intake panels and move coverings sideways until the liquid pressure is in the above noted ranges.

IF REFRIGERANT ADDED OR REMOVED, VERIFY CHARGE USING THE APPROACH METHOD



IF VALUE IS GREATER THAN SHOWN, REMOVE REFRIGERANT; IF LESS THAN SHOWN, ADD REFRIGERANT



**SC° (Subcooling) Values (F: +/-1.0° [C: +/-0.6°])**

	-036	-048	-060
TEMP*	6 (3.3)	6 (3.3)	9 (5.0)

\*Temperature of air entering outdoor coil is 65°F (18°C) or above.

\* THESE SUBCOOLING VALUES ARE ALSO LISTED ON THE UNIT CHARGING STICKER 580005-01 LOCATED ON THE ACCESS PANEL.

- 1.. CONFIRM PROPER AIRFLOW ACROSS COIL USING FIGURE 12.
- 2.. COMPARE UNIT PRESSURES WITH TABLE 8, *NORMAL OPERATING PRESSURES*.
- 3.. USE SUBCOOLING TO CORRECTLY CHARGE UNIT OR TO VERIFY THE CHARGE IS CORRECT.
- 4.. SET THERMOSTAT TO CALL FOR HEAT (MUST HAVE A COOLING LOAD BETWEEN 70-80°F (21-26°C))
- 5.. CONNECT GAUGE SET
- 6.. MEASURE OUTDOOR AMBIENT TEMPERATURE
- 7.. WHEN HEAT DEMAND IS SATISFIED, SET THERMOSTAT TO CALL FOR COOLING
- 8.. ALLOW TEMPERATURES AND PRESSURES TO STABILIZE.  
*NOTE - IF NECESSARY, BLOCK OUTDOOR COIL TO MAINTAIN 325 - 375 PSIG*
- 9.. RECORD LIQUID LINE TEMPERATURE:  
**LIQ° = \_\_\_\_\_**
- 10.. MEASURE LIQUID LINE PRESSURE AND USE THE VALUE TO DETERMINE SATURATION TEMPERATURE (SEE TABLE 9):  
**SAT° = \_\_\_\_\_**
- 11.. SUBTRACT TO DETERMINE SUBCOOLING (SC°):  
**SAT° \_\_\_\_\_ - LIQ° \_\_\_\_\_ = SC° \_\_\_\_\_**
- 12.. COMPARE RESULTS WITH TABLE TO THE LEFT.

**Figure 16. Using Subcooling Test and Charge Method**

**Table 8. Normal Operating Pressures\*\***

**⚠ IMPORTANT**

Use this table to perform maintenance checks; it is not a procedure for charging the system. Minor variations in these pressures may be due to differences in installations. Significant deviations could mean that the system is not properly charged or that a problem exists with some component in the system.

Model	SSB036H4S41		SSB048H4S41		SSB060H4S41	
°F (°C)*	Liquid	Suction	Liquid	Suction	Liquid	Suction
<b>First Stage (Low Capacity)</b>						
65 (18)	226	142	224	142	215	136
75 (24)	261	144	258	144	250	139
85 (29)	304	145	299	146	291	142
95 (35)	352	147	345	148	337	144
105 (41)	405	150	395	150	388	146
115 (46)	460	150	450	153	444	148
<b>Second Stage (High Capacity)</b>						
65 (18)	228	144	235	135	220	130
75 (24)	262	146	269	137	256	133
85 (29)	306	148	313	139	299	136
95 (35)	353	150	361	141	347	138
105 (41)	405	151	412	143	402	141
115 (46)	462	154	471	146	462	143

\*Temperature of air entering outdoor coil.

\*\* (Liquid ±10 psig; Vapor ±5 psig) Typical pressures; indoor unit match up, indoor air quality equipment, and indoor load will cause the pressures to vary.

**TABLE 9**

R-410A Temperature (°F) - Pressure (Psig)							
°F	Psig	°F	Psig	°F	Psig	°F	Psig
32	100.8	64	181.6	96	299.4	126	451.8
34	105.0	66	187.7	98	308.2	128	463.5
36	109.2	68	194.1	100	317.2	130	475.6
38	113.6	70	200.6	102	326.4	132	487.8
40	118.0	72	207.2	104	335.7	134	500.2
42	122.6	74	214.0	106	345.3	136	512.9
44	127.3	76	220.9	108	355.0	138	525.8
46	132.2	78	228.0	110	365.0	140	539.0
48	137.1	80	235.3	112	375.1	142	552.3
50	142.2	82	242.7	114	385.4	144	565.9
52	147.4	84	250.3	116	396.0	146	579.8
54	152.8	86	258.0	118	406.7	148	593.8
56	158.2	88	266.0	120	417.7	150	608.1
58	163.9	90	274.1	122	428.8	152	622.7
60	169.6	92	282.3	124	440.2	154	637.5
62	195.5	94	290.8	126	451.8	156	652.4

**V - SERVICE AND RECOVERY**

**⚠ WARNING**

Polyol ester (POE) oils used with R-410A refrigerant absorb moisture very quickly. It is very important that the refrigerant system be kept closed as much as possible. **DO NOT** remove line set caps or service valve stub caps until you are ready to make connections.

**⚠ IMPORTANT**

**USE RECOVERY MACHINE RATED FOR R-410A REFRIGERANT.**

If the SSB\*H4 system must be opened for any kind of service, such as compressor or drier replacement, you must take extra precautions to prevent moisture from entering the system. The following steps will help to minimize the amount of moisture that enters the system during recovery of R-410A.



- 1 - Use a regulator-equipped nitrogen cylinder to break the system vacuum. Do not exceed 5 psi. The dry nitrogen will fill the system, purging any moisture.
- 2 - Remove the faulty component and quickly seal the system (using tape or some other means) to prevent additional moisture from entering the system.
- 3 - Do not remove the tape until you are ready to install new component. Quickly install the replacement component.
- 4 - Evacuate the system to remove any moisture and other non-condensables.

**Any time the SSB\*H4 sealed system is opened, the drier must be replaced and the system must be evacuated.**

Any moisture not absorbed by the polyol ester oil can be removed by evacuation. Moisture that has been absorbed by the compressor oil can be removed by replacing the drier.

 <b>IMPORTANT</b>
<b>Evacuation of system only will not remove moisture from oil. Drier must be replaced to eliminate moisture from POE oil.</b>

## VI - MAINTENANCE

 <b>WARNING</b>
 <b>Electric shock hazard. Can cause injury or death. Before attempting to perform any service or maintenance, turn the electrical power to unit OFF at disconnect switch(es). Unit may have multiple power supplies.</b>

At the beginning of each cooling season, the system should be serviced. In addition, the system should be cleaned as follows:

## A - Outdoor Unit

- 1 - Clean and inspect the outdoor coil. The coil may be flushed with a water hose. Ensure the power is turned off before you clean the coil.
- 2 - Condenser fan motor is prelubricated and sealed. No further lubrication is needed.
- 3 - Visually inspect connecting lines and coils for evidence of oil leaks.
- 4 - Check wiring for loose connections.
- 5 - Check for correct voltage at unit (unit operating).
- 6 - Check amp-draw condenser fan motor.  
Unit nameplate \_\_\_\_\_ Actual \_\_\_\_\_ .

*NOTE - If owner complains of insufficient cooling, the unit should be gauged and refrigerant charge checked. Refer to section on refrigerant charging in this instruction.*

## B - Indoor Coil

- 1 - Clean coil, if necessary.
- 2 - Check connecting lines and coils for evidence of oil leaks.
- 3 - Check the condensate line and clean it if necessary.

## C - Indoor Unit

- 1 - Clean or change filters.
- 2 - Adjust blower speed for cooling. Measure the pressure drop over the coil to determine the correct blower CFM. Refer to the unit information service manual for pressure drop tables and procedure.
- 3 - *Belt Drive Blowers* - Check belt for wear and proper tension.
- 4 - Check all wiring for loose connections
- 5 - Check for correct voltage at unit (blower operating).
- 6 - Check amp-draw on blower motor  
Unit nameplate \_\_\_\_\_ Actual \_\_\_\_\_ .

# VII - WIRING DIAGRAMS AND SEQUENCE OF OPERATION

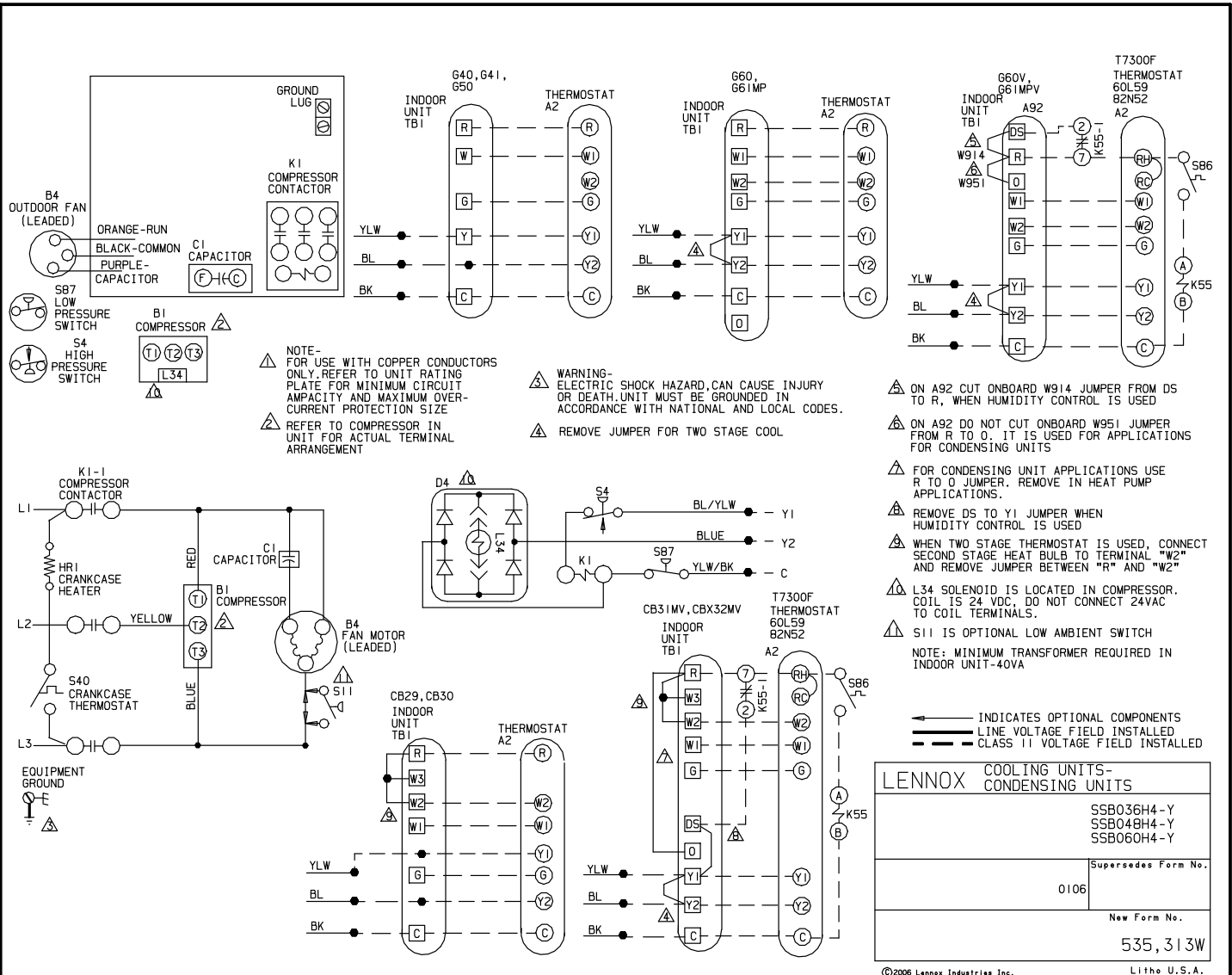

## Sequence of Operation SSB\*H4

*NOTE - First and second stage cool operate independent of each other and can modulate back and forth according to thermostat demand.*

### First Stage Cool (low capacity)

1. Cooling demand initiates at Y1 in the thermostat.
2. Voltage from terminal Y passes through S4 high pressure switch, energizes K1 compressor contactor, passes through S87 low pressure switch and returns to common side of the 24VAC power.
3. K1 closes energizing B1 compressor and B4 outdoor fan.
4. Solenoid L34 is NOT energized so the slider ring remains open, limiting compressor to low capacity.

### Second Stage Cool (high capacity)

*Compressor is operating in first stage cool*

- 5- Second stage thermostat demand sends voltage to rectifier plug D4. D4 converts the AC voltage to DC voltage and energizes L34 unloader solenoid. L34 then closes the slider ring, allowing the compressor to operate at high capacity.

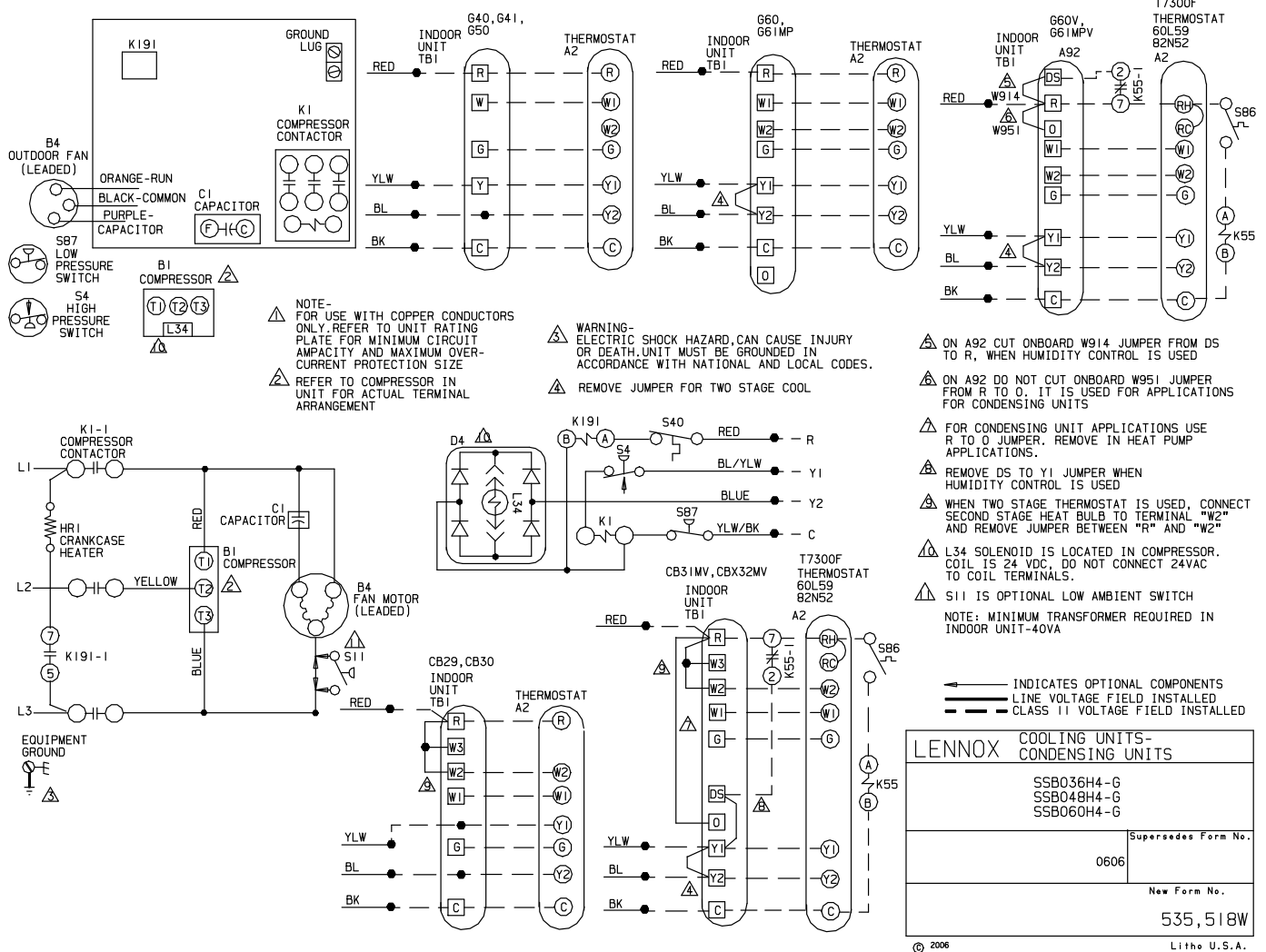

### Sequence of Operation SSB\*H4

*NOTE - First and second stage cool operate independent of each other and can modulate back and forth according to thermostat demand.*

#### First Stage Cool (low capacity)

1. Cooling demand initiates at Y1 in the thermostat.
2. Voltage from terminal Y passes through S4 high pressure switch, energizes K1 compressor contactor, passes through S87 low pressure switch and returns to common side of the 24VAC power.
3. K1 closes energizing B1 compressor and B4 outdoor fan.
4. Solenoid L34 is NOT energized so the slider ring remains open, limiting compressor to low capacity.

#### Second Stage Cool (high capacity)

*Compressor is operating in first stage cool*

- 5- Second stage thermostat demand sends voltage to rectifier plug D4. D4 converts the AC voltage to DC voltage and energizes L34 unloader solenoid. L34 then closes the slider ring, allowing the compressor to operate at high capacity.